

# Current Transducer IT 700-S ULTRASTAB

$I_{PM} = 700 A$

For ultra-high precision measurement of current: DC, AC, pulsed..., with galvanic separation between primary and secondary.



## Features

- Closed loop (compensated) current transducer using an extremely accurate zero flux detector
- Electrostatic shield between primary and secondary circuit
- 9-pin D-Sub male secondary connector
- Status signal to indicate the transducer state
- LED indicator confirms normal operation.

## Advantages

- Very high accuracy
- Excellent linearity
- Extremely low temperature drift
- Wide frequency bandwidth
- High immunity to external fields
- No insertion losses
- Low noise on output signal
- Low noise feedback to primary conductor.

## Applications

- Feed back element in high performance gradient amplifiers for MRI
- Feedback element in high-precision, high-stability power supplies
- Calibration unit
- Energy measurement
- Medical equipment.

## Standards

- EN 61000-6-2: 2005
- EN 61000-6-3: 2007
- EN 61010-1: 2010.

## Application Domains

- Industrial
- Laboratory
- Medical.

**Insulation coordination**

Parameter	Symbol	Unit	Value	Comment
Rated insulation rms voltage, basic insulation	$U_b$	V	1600	IEC 61010-1 conditions - over voltage cat III - pollution degree 2
Rated insulation rms voltage, reinforced insulation	$U_b$	V	300	IEC 61010-1 conditions - over voltage cat III - pollution degree 2
Rated insulation rms voltage, basic insulation	$U_b$	V	1000	EN 50178 conditions - over voltage cat III - pollution degree 2
Rated insulation rms voltage, reinforced insulation	$U_b$	V	600	EN 50178 conditions - over voltage cat III - pollution degree 2
Rms voltage for AC insulation test, 50/60 Hz, 1 min	$U_d$	kV	4.6	Between primary and secondary + shield
		V DC	200	Between secondary and shield
		V DC	500	Between secondary and status output
Impulse withstand voltage 1.2/50 $\mu$ s	$\hat{U}_w$	kV	8.5	
Clearance (pri. - sec.)	$d_{Cl}$	mm	9	Shortest distance through air
Creepage distance (pri. - sec.)	$d_{cp}$	mm	9	Shortest path along device body
Comparative tracking index	$CTI$	V	600	

If insulated cable is used for the primary circuit, the voltage category could be improved with the following table (for single insulation) (IEC 61010-1 standard):

Cable insulated (primary)	Category
HAR03	1750 V CAT III
HAR05	1850 V CAT III
HAR07	1950 V CAT III

**Environmental and mechanical characteristics**

Parameter	Symbol	Unit	Min	Typ	Max	Comment
Ambient operating temperature	$T_A$	°C	10		50	
Ambient storage temperature	$T_S$	°C	-20		85	
Relative humidity	$RH$	%	20		80	Non-condensing
Dimensions						See drawing page 8
Mass	$m$	kg		0.8		

**Electrical data**

 At  $T_A = 25\text{ °C}$ ,  $\pm U_C = \pm 15\text{ V}$ , unless otherwise noted.

Parameter	Symbol	Unit	Min	Typ	Max	Comment
Primary continuous direct current	$I_{PNDC}$	A	-700		700	
Primary nominal rms current	$I_{PN}$	A			495	
Primary current, measuring range	$I_{PM}$	A	-700		700	
Measuring resistance Over operating current, temperature and supply voltage range	$R_M$	$\Omega$	0		2.5	See graph page 4
Secondary current	$I_S$	A	-0.4		0.4	
Conversion ratio	$K_N$			1:1750		
Resistance of secondary winding	$R_S$	$\Omega$		20		
Overload capability <sup>1)</sup>	$\hat{I}_P$	kA	-3.5		3.5	@ pulse of 100 ms
Supply voltage	$U_C$	V	$\pm 14.25$	$\pm 15$	$\pm 15.75$	
Current consumption	$I_C$	mA			80	Add $I_S$ for total current consumption
Output rms noise 0 .. 10 Hz <sup>2)</sup>	$V_{no}$	ppm			0.05	
Output rms noise 0 .. 100 Hz <sup>2)</sup>					0.5	
Output rms noise 0 .. 1 kHz <sup>2)</sup>					1	
Output rms noise 0 .. 10 kHz <sup>2)</sup>					3	
Output rms noise 0 .. 50 kHz <sup>2)</sup>					6	
Re-injected rms noise on primary bus bar		$\mu\text{V}$			5	0 .. 50 kHz
Electrical offset current + self magnetization + effect of earth magnetic field <sup>2)</sup>	$I_{OE}$	ppm	-50		50	
Temperature coefficient of $I_{OE}$ <sup>2)</sup>	$TCI_{OE}$	ppm/K	-0.5		0.5	10 °C .. 50 °C
Offset stability <sup>2)</sup>		ppm/month	-0.5		0.5	
Linearity error <sup>2)</sup>	$\epsilon_L$	ppm	-3		3	
Step response time to 90 % of $I_{PNDC}$	$t_r$	$\mu\text{s}$			1	di/dt of 100 A/ $\mu\text{s}$
di/dt accurately followed	di/dt	A/ $\mu\text{s}$	100			
Frequency bandwidth ( $\pm 1\text{ dB}$ )	$BW$	kHz	0	50		Small-signal bandwidth, 0.5% of $I_{PM}$
Frequency bandwidth ( $\pm 3\text{ dB}$ )	$BW$	kHz	0	100		Small-signal bandwidth, 0.5% of $I_{PM}$

- Notes:**
- <sup>1)</sup> Single pulse only, not AC. The transducer may require a few seconds to return to normal operation when autoreset system is running.
  - <sup>2)</sup> All ppm figures refer to full-scale which corresponds to a secondary current ( $I_S$ ) of 0.4 A.

### Overload protection - Electrical specification - Status

The overload occurs when the primary current  $I_p$  exceeds a trip level such that the fluxgate detector becomes completely saturated and, consequently, the transducer will switch from normal operation to overload mode.

This trip level is guaranteed to be greater than 110 % of  $I_{PNDC}$  and its actual value depends on operating conditions such as temperature and measuring resistance.

When this happens, the transducer will automatically begin to sweep in order to lock on the primary current again and the measuring can resume when the primary current returns in the nominal range between  $-I_{PNDC}$  and  $+I_{PNDC}$ .

In overload mode, the secondary current generated is a low frequency triangle waveform between - 0.4 A and 0.4 A.

Under these conditions:

- The contact (normal operation status) between pin 3 and 8 (of the D-sub connector) switches off, this contact becomes open.
- The green LED indicator (normal operation status) turns off.

Max voltage pin 3 and pin 8, off-State	100 V
Max current pin 3 and pin 8, on-State	1000 mA
On-State resistance pin 3 and pin 8:	50 mΩ (typ)

**TO ENSURE A SAFE RECOVERY FROM SATURATION, THE MAXIMUM BURDEN RESISTOR ALLOWED IS 2.5 Ω.**

### Maximum measuring resistor versus primary current

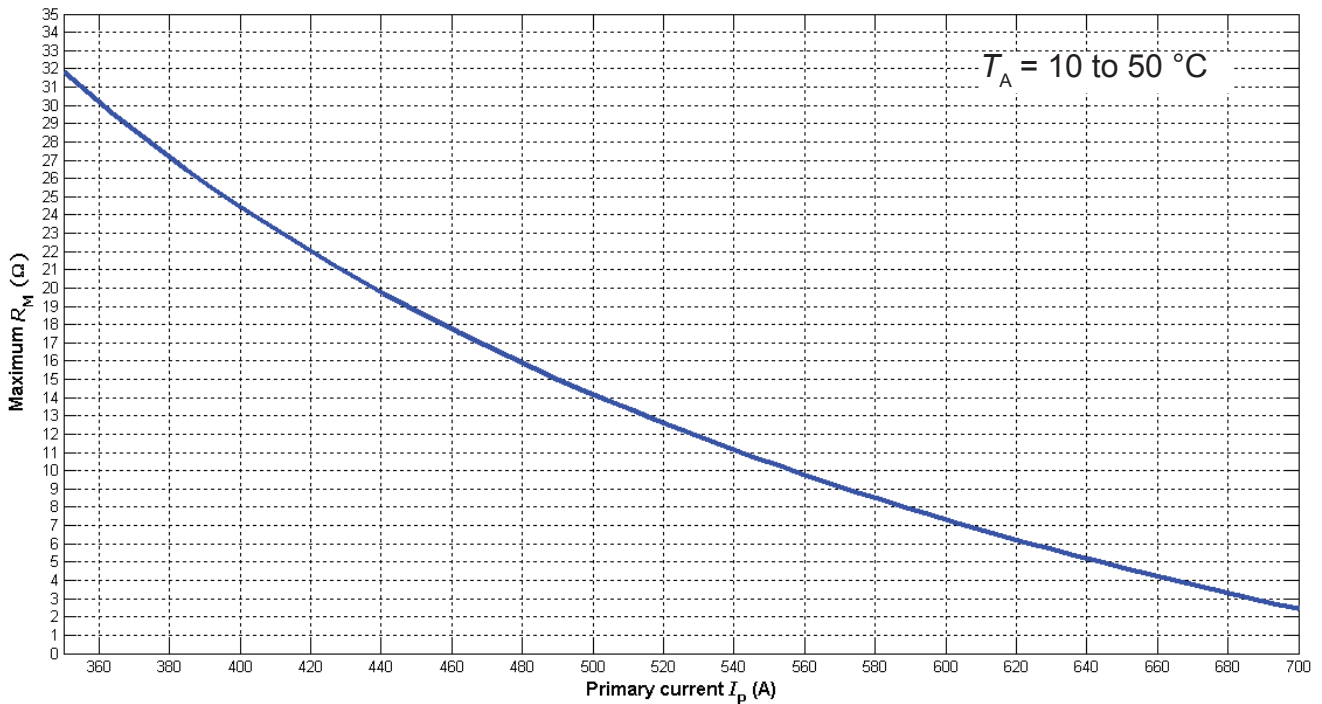

Status/Interlock port wiring

Example of application  
Status/Interlock port wiring

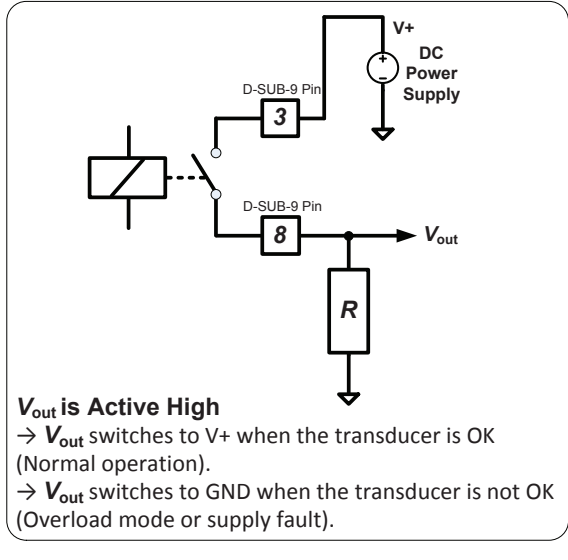
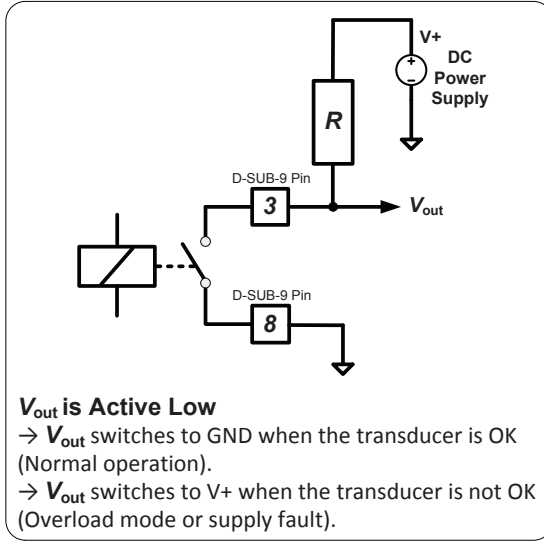

Circuit diagram for using  $R_M > 2.5 \Omega$

This circuit ensures a safe recovery from saturation when using  $R_M > 2.5 \Omega$ . It allows the transducer to recover normal operation in case  $R_M$  is greater than  $2.5 \Omega$  and an overload is detected by the transducer.

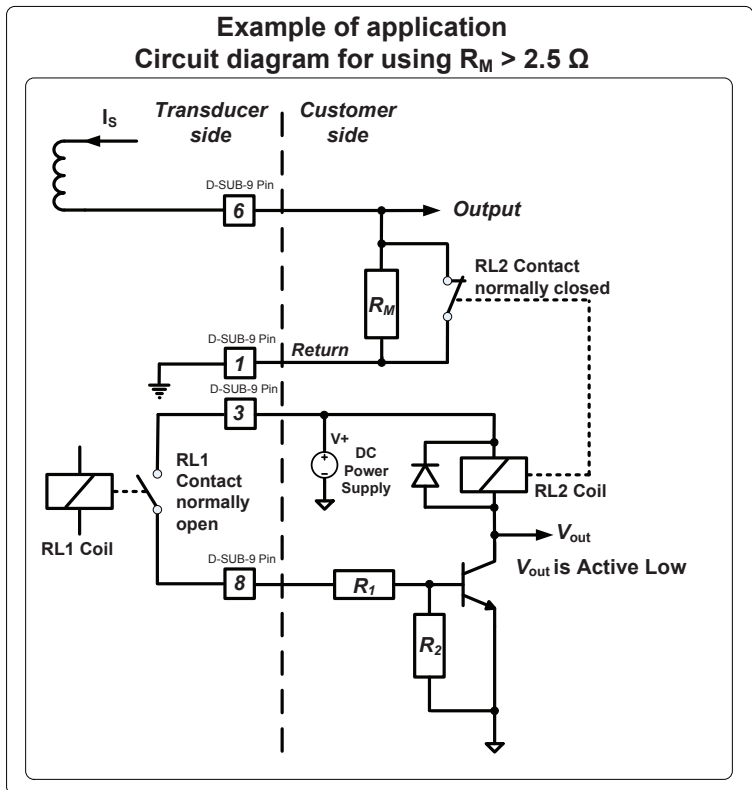

Contact RL1 (Pins 3 and 8)	Contact RL2	V <sub>out</sub>	Description
Closed	Open	Low (switches to GND)	The transducer is OK (Normal operation)
Open	Closed	High (switches to V+)	The transducer is not OK (Overload mode or supply fault)

## Safety

This transducer must be used in limited-energy secondary circuits according to IEC 61010-1.



This transducer must be used in electric/electronic equipment with respect to applicable standards and safety requirements in accordance with the manufacturer's operating instructions.



Caution, risk of electrical shock

When operating the transducer, certain parts of the module can carry hazardous voltage (eg. primary busbar, power supply). Ignoring this warning can lead to injury and/or cause serious damage.

This transducer is a build-in device, whose conducting parts must be inaccessible after installation.

A protective housing or additional shield could be used.

Main supply must be able to be disconnected.

### Performance parameters definition

The schematic used to measure all electrical parameters is shown below:

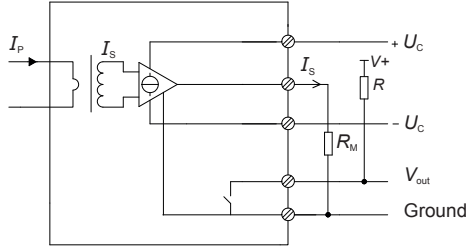

### Transducer simplified model

The static model of the transducer at temperature  $T_A$  is:

$$I_S = K_N \cdot I_P + \text{error}$$

In which

$$\text{error} = I_{OE} \text{ at } 25^\circ\text{C} + I_{OT}(T_A) + \epsilon_L \cdot I_{PM} \cdot K_N$$

Where,

$$I_{OT}(T_A) = TCI_{OE} \cdot |T_A - 25^\circ\text{C}| \cdot I_{PM} \cdot K_N$$

- $I_S$  : secondary current (A)
- $K_N$  : conversion ratio
- $I_P$  : primary current (A)
- $I_{PM}$  : primary current, measuring range (A)
- $T_A$  : ambient operating temperature ( $^\circ\text{C}$ )
- $I_{OE}$  : electrical offset current (A)
- $I_{OT}$  : temperature variation of  $I_{OE}$  at  $T_A$  (A)
- $\epsilon_L$  : linearity error

This is the absolute maximum error. As all errors are independent, a more realistic way to calculate the error would be to use the following formula:

$$\text{error} = \sqrt{\sum(\text{error\_component})^2}$$

### Linearity

To measure linearity, the primary current (DC) is cycled from 0 to  $I_{PM}$ , then to  $-I_{PM}$  and back to 0 (equally spaced  $I_{PM}/10$  steps). The linearity error  $\epsilon_L$  is the maximum positive or negative difference between the measured points and the linear regression line, expressed in parts per million (ppm) of full-scale which corresponds to the maximum measured value.

### Electrical offset

The electrical offset current  $I_{OE}$  is the residual output current when the input current is zero.

The temperature variation  $I_{OT}$  of the electrical offset current  $I_{OE}$  is the variation of the electrical offset from  $25^\circ\text{C}$  to the considered temperature.

### Response time

The response time  $t_r$  is shown in the next figure. It depends on the primary current  $di/dt$  and it's measured at nominal current.

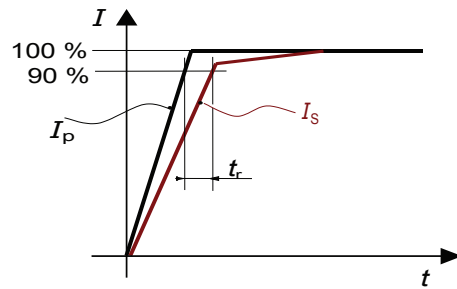

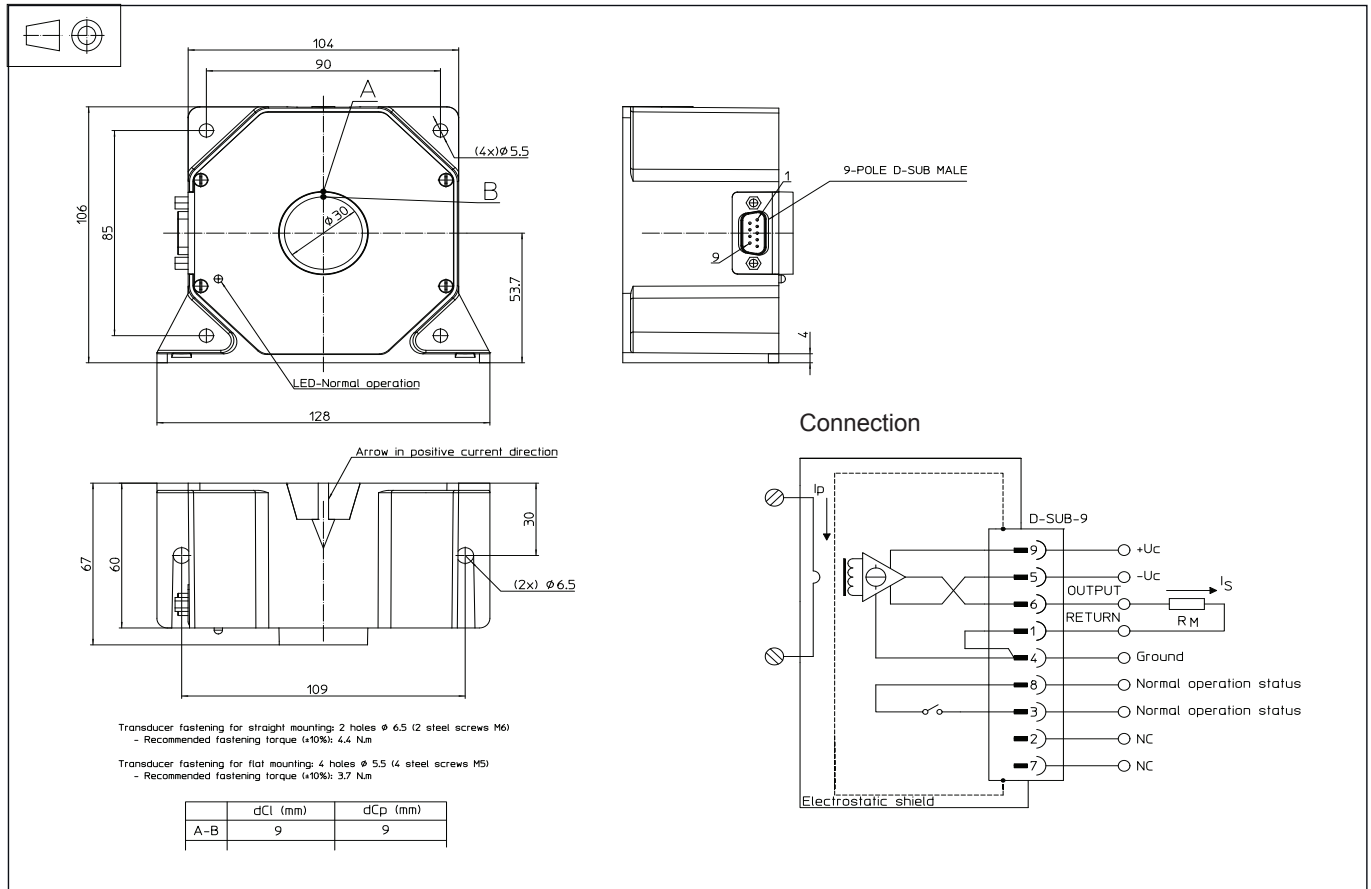
**Dimensions (in mm)**

**Connection**

- Normal operation status (Pins 3 and 8)  
Normal operation means:
  - $\pm 15\text{ V}$  ( $\pm U_c$ ) present
  - zero detector is working
  - compensation current  $\leq 110\%$  of  $I_{PN\ DC}$
  - green LED indicator is lit.

Contact (Pins 3 and 8)	Description
Closed	The transducer is OK (Normal operation)
Open	The transducer is not OK (Overload mode or supply fault)

**Remarks**

- $I_S$  is positive when  $I_P$  flows in the direction of the arrow.
- We recommend that a shielded output cable and plug are used to ensure the maximum immunity against electrostatic fields.
- Pin 4 should be connected to cable and connector shield to maintain lowest output noise.
- Temperature of the primary conductor should not exceed  $50\text{ }^\circ\text{C}$ .

**Mechanical characteristics**

- General tolerance  $\pm 0.3\text{ mm}$
- Transducer fastening
  - Straight mounting: 2 holes  $\phi 6.5\text{ mm}$ , 2 x M6 steel screws, Recommended fastening torque 4.4 Nm
  - Flat mounting: 4 holes  $\phi 5.5\text{ mm}$ , 4 x M5 steel screws, Recommended fastening torque 3.7 Nm
- Connection of secondary connector on D-SUB-9, UNC 4-40
- All mounting recommendations are given for a standard mounting. Screws with flat and spring washers.
- Primary through hole  $\phi \leq 30\text{ mm}$
- Installation of the transducer must be done unless otherwise specified on the datasheet, according to LEM Transducer Generic Mounting Rules. Please refer to LEM document N°ANE120504 available on our Web site: [Products/Product Documentation](#).