

3-PCS PREMIUM BALL VALVE

TYPE 1211: STEEL
TYPE 1311: STAINLESS STEEL



GENERAL

SIZE/PRESSURE:	1/4" - 1" FB = 125 BAR 1 1/4" - 1 1/2" FB = 100 BAR 2" - 4" FB = 64 BAR
TEMPERATUR:	-28°C TIL 220°C (STEEL - TYPE 1211) -38°C TIL 220°C (STAINLESS - TYPE 1311)
(PRESSURE AND TEMPERATURE ARE INTERDEPENDENT)	
ISO TOP FLANGE:	EN ISO 5211
THREAD ENDS:	BSPP - EN ISO 228-1
BUTT WELD ENDS:	TYPE 1211 - EN 12627 TYPE 1311 - DIN 2463 / EN ISO 1127 LINE 1 - DIN 11850-2 (FB) - SMS 3008
BALL SURFACE HARDENING:	300HV
OPTION	
EDITION:	FIRE SAFE API 607 AND ISO 10497
CONNECTION:	VARIOUS. BSPT, NPT, ANSI B 2.1, JISPT, SCH. 10 & 40, SOCKET WELD ENDS ANSI B 16.11
SEAT/PACKING:	PEEK, 50%SS/PTFE, DELRIN, CAVITY FILLER *FDA (PTFE+GLASS FIBRE / PTFE)
BALL HARDENING:	1200HV +/- 100HV

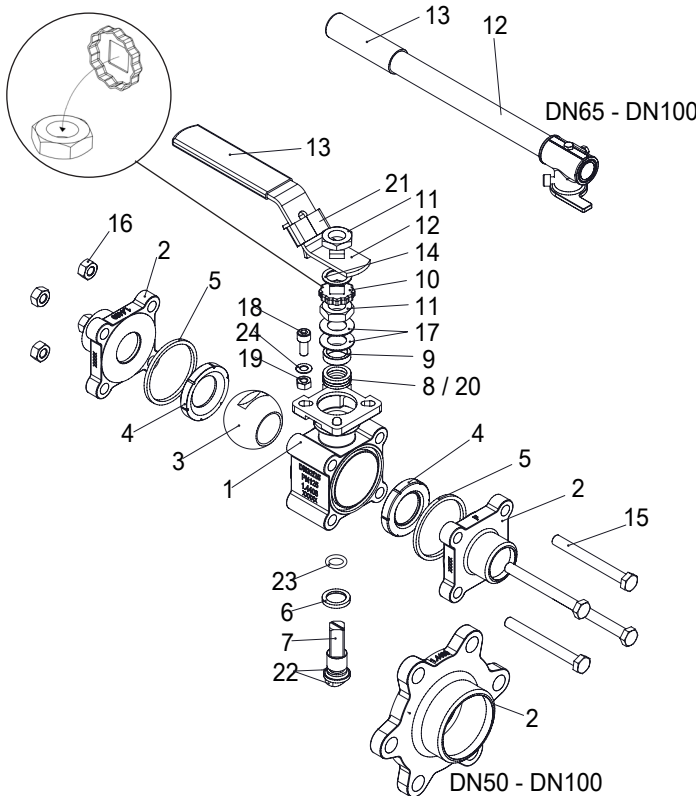

POS	DESCRIPTION	MATERIAL
1	BODY *	STAINLESS STEEL CF8M
2	CONNECTION *	STAINLESS STEEL CF3M/CF8M (THREAD)
3	BALL	STAINLESS STEEL CF8M
4	SEAT PACKING	PTFE WITH 25% CARBON
5	JOINT GASKET	PTFE WITH 15% GLASS FIBRE
6	CONIC PACKING RING	PTFE WITH 25% CARBON
7	STEM	STAINLESS STEEL AISI 316
8	STEM SEAL	PTFE WITH 25% CARBON
9	GLAND	STAINLESS STEEL AISI 304
10	LOCK SADDLE	STAINLESS STEEL AISI 304
11	STEM NUT	STAINLESS STEEL AISI 304
12	HANDLE	STAINLESS STEEL AISI 304
13	HANDLE SLEEVE	VINYL
14	WASHER	STAINLESS STEEL AISI 304
15	BOLT	STAINLESS STEEL AISI 304
16	NUT	STAINLESS STEEL AISI 304
17	BELLEVILLE WASHER	STAINLESS STEEL AISI 301
18	STOP BOLT	STAINLESS STEEL AISI 304
19	NUT	STAINLESS STEEL AISI 304
20	BUSHING	75% PTFE/20% GLASS FIBRE/5% GRAPHITE
21	LOCKING DEVICE	STAINLESS STEEL AISI 304
22	ANTI-STATIC DEVICE	STAINLESS STEEL AISI 304
23	O-RING	FPM
24	WASHER	STAINLESS STEEL AISI 304

≥DN65FB includes backup for seat ring in stainless steel
 * Type 1211 A216 Gr. WCB

DESCRIPTION

- **Solid ball valve for high performance tasks.** All ball valves are pressure tested. Can on demand be delivered with certificate EN10204/3.1.
- **Bolt circle diameter and face to face dimensions** of the body is equal to Worcester, Valtac and Mecafrance from DN15 to DN65 RB. This means that our Type 1211/1311 can be mounted between existing end caps.
- **PTFE with 25% carbon filled** are used for seats and pyramid segment. This material is very suitable for high pressure and temperature and it's even more resistant to wear than traditional PTFE.
- **Maintenance free stuffing box** with belleville washers, reinforced V-rings and FPM O-ring will provide optimum packing and longer lifetime - also at various temperatures.
- **Antistatic stem with dynamic stuffing box.** Stem with 45° face of contact. This means larger contact area together with reinforced stem seat and a surface quality on Ra 0.2 ~ 0.3 µm. These advantages provides the possibility of a very long lifetime.
- **Stainless steel butt weld caps according to ISO 1127** is standard. From stock we can also deliver BSPP threaded ends and butt weld ends according to DIN 11850-2 in FB and SMS 3008.
- **Increased surface hardness of the ball** can be opted for extremely abrasive media to be more resistant to wear and thus extend the lifespan of the ball.
- **Option: FIRE SAFE approved according to AP607 6TH edition and ISO 10497**, with stem and joint gasket in graphite.
- **Approvals:** TA-Luft, FDA, EC1935, ATEX, SIL3, TR TS 032/2013, 012/2011, 010/2011.

DIMENSIONS

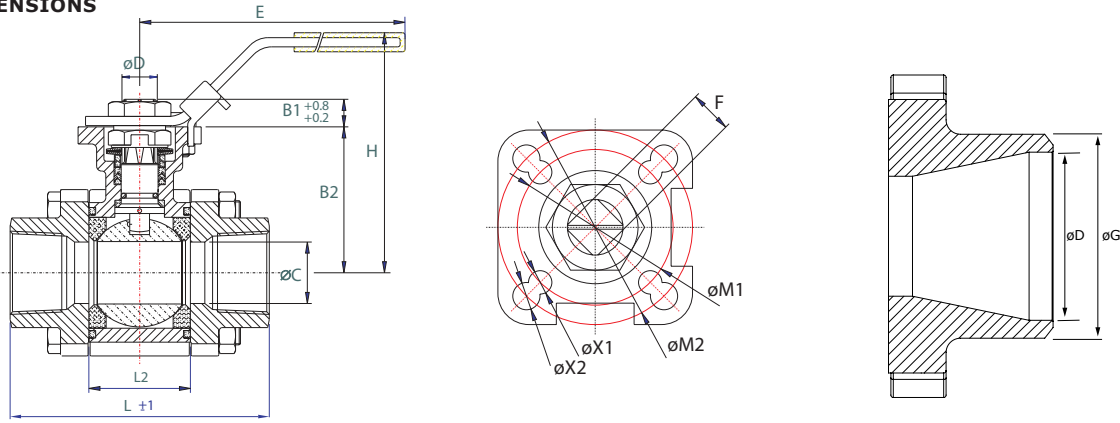

DIMENSION [MM]	VALVE WITH HANDLE									ISO TOP FLANGE					STEM		
	L [MM]				L2	B2	ØC	E	H	ISO 5211	ØM1	ØX1X4	ISO 5211	ØM2	ØX2X4	F	B1
	THREAD	BW	SMS	FLANGE	[MM]	[MM]	[MM]	[MM]	[MM]		[MM]	[MM]		[MM]	[MM]	[MM]	[MM]
DN08FB	75.0	75.0	75.0	-	24.5	42.6	11.5	139	77.0	F03	36	6.0	F04	42	6	9	7.6
DN10FB/DN15RB	75.0	75.0	75.0	-	24.5	42.6	12.6	139	77.0	F03	36	6.0	F04	42	6	9	7.6
DN15FB/DN20RB	73.0	75.0	75.0	130	24.5	42.6	15.0	139	77.0	F03	36	6.0	F04	42	6	9	7.6
DN20FB/DN25RB	86.0	90.0	90.0	150	31.4	46.9	20.0	139	82.0	F03	36	6.0	F04	42	6	9	8.6
DN25FB/DN32RB	106.0	110.0	110.0	160	41.3	59.3	25.0	165	98.5	F04	42	6.0	F05	50	7	11	10.4
DN32FB/DN40RB	111.0	115.0	115.0	180	48.4	62.6	32.0	165	102.0	F04	42	6.0	F05	50	7	11	10.4
DN40FB/DN50RB	128.0	130.0	130.0	200	56.3	79.0	38.0	215	128.0	F05	50	7.5	F07	70	9	14	13.4
DN50FB/DN65RB	143.0	143.0	143.0	230	71.4	87.7	50.0	215	137.0	F05	50	7.5	F07	70	9	14	13.4
DN65FB/DN80RB	185.0	185.0	185.0	290	86.6	108.7	65.0	262	167.0	F07	70	10.0	F10	102	12	17	16.8
DN80FB/DN100RB	205.0	205.0	205.0	310	99.0	117.7	76.0	262	176.0	F07	70	10.0	F10	102	12	17	17.8
DN100FB	240.0	240.0	240.0	350	127.0	133.7	100	312	192.0	F07	70	10.0	F10	102	12	17	16.8

DIM		*)TORQUE		**)WEIGHT		KV-VALUE		BUTT WELD ENDS [R=REDUCE BORE] [F=FULL BORE]							
[MM]	[INCH]	FB [NM]	RB [NM]	FB [KG]	RB [KG]	90° M³/H		TYPE 1211		TYPE 1311		TYPE 1311		TYPE 1311	
						FB	RB	EN 12627		ISO 1127		SMS 3008		DIN 11850-2	
								ØG/ØD (MM)		ØG/ØD (MM)		ØG/ØD (MM)		ØG/ØD (MM)	
DN08	1/4"	9	-	0.85	-	6.9	-	14 / 11.5 (1.25)	F	13.5/10.3 (1.6)	F	-	-	-	-
DN10	3/8"	9	-	0.83	-	6.9	-	17.2/12.6 (2.3)	F	17.2/14.0 (1.6)	F	12.0/10.0 (1.0)	F	13.0 /10.0(1.5)	F
DN15	1/2"	11	9	0.80	0.82	12.7	6.9	21.7 / 15 (3.35)	R/F	21.3/18.1 (1.6)	R/F	18.0/16.0 (1.0)	R	19.0/16.0 (1.5)	F
DN20	3/4"	12	11	1.30	0.83	29.2	12.7	27.2/20.5 (3.35)	R/F	26.9/23.7 (1.6)	R/F	25.0/22.6 (1.2)	R/F	23.0/20.0 (1.5)	F
DN25	1"	19	12	2.00	1.35	48.2	29.2	34/25.7 (4.15)	R/F	33.7/29.7 (2.0)	R/F	32.0/29.6 (1.2)	R	29.0/26.0 (1.5)	F
DN32	1 1/4"	28	19	2.75	2.10	73.1	48.2	42.7/34.4 (4.15)	R/F	42.4/38.4 (2.0)	R/F	33.7/31.3 (1.2)	R	35.0/32.0 (1.5)	F
DN40	1 1/2"	37	28	4.25	2.85	107.5	73.1	48.6/40.3 (4.15)	R/F	48.3/44.3 (2.0)	R/F	38.0/35.6 (1.2)	R	41.0/38.0 (1.5)	F
DN50	2"	52	37	5.80	4.40	215.0	107.5	60.5/51.3 (4.6)	R/F	60.3/55.1 (2.6)	R/F	51.0/48.6 (1.2)	R	53.0/50.0 (1.5)	F
DN65	2 1/2"	68	52	11.15	7.15	275.2	215.0	76.3/67.1 (4.6)	R/F	76.1/70.9 (2.6)	R/F	63.5/60.3 (1.6)	R	70.0/66.0 (2.0)	F
DN80	3"	100	68	14.80	11.45	498.8	275.2	88.9/80.0 (4.45)	R/F	88.9/83.7 (2.6)	R/F	76.1/72.9 (1.6)	R	85.0/81.0 (2.0)	F
DN100	4"	112	100	23.70	15.70	877.2	498.8	116/103.1 (6.45)	R/F	114.3/109.1 (2.6)	R/F	101.6/97.6 (2.0)	R	104.0/100.0 (2.0)	F

*) Torque figures include 30% safety factor. (TEST: 0bar diff. pressure, ambient temperature, non-lubricating)
 Torque is based on standard seats packing PTFE with 25% carbon.
 Torque on request: Seat packing PTFE TFM1600, PEEK, PTFE with 50% SS, DELRIN, PTFE with 15% glass fibre.

**) Weight is based on flower shaped welding ends ISO 1127.

PRESSURE/TEMPERATURE

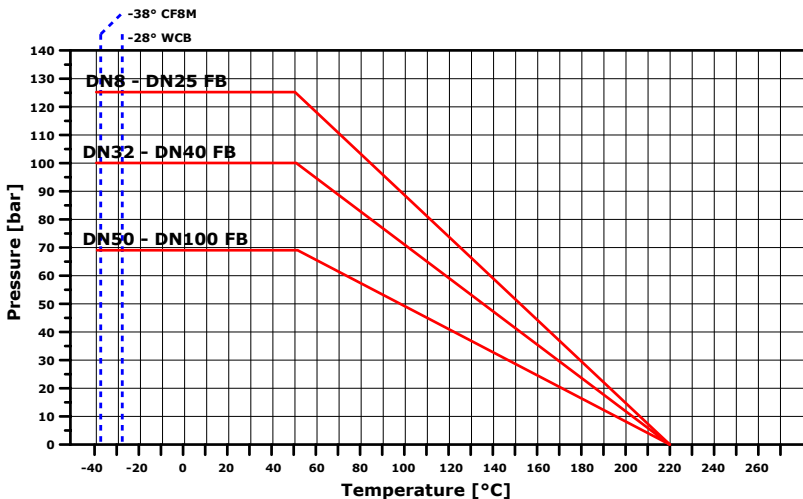

Helium leakage test
 performed by German laboratory

Two tests have been executed with vacuum inside valve – spray with helium on the outside:

- 1 x closed position, tightness on seats (flow direction)
- 1 x half open position, tightness on stem and body sealings

Test result leakage rate: 10^{-7} mbar * l * s⁻¹

Further details can be seen on the test certificate.