

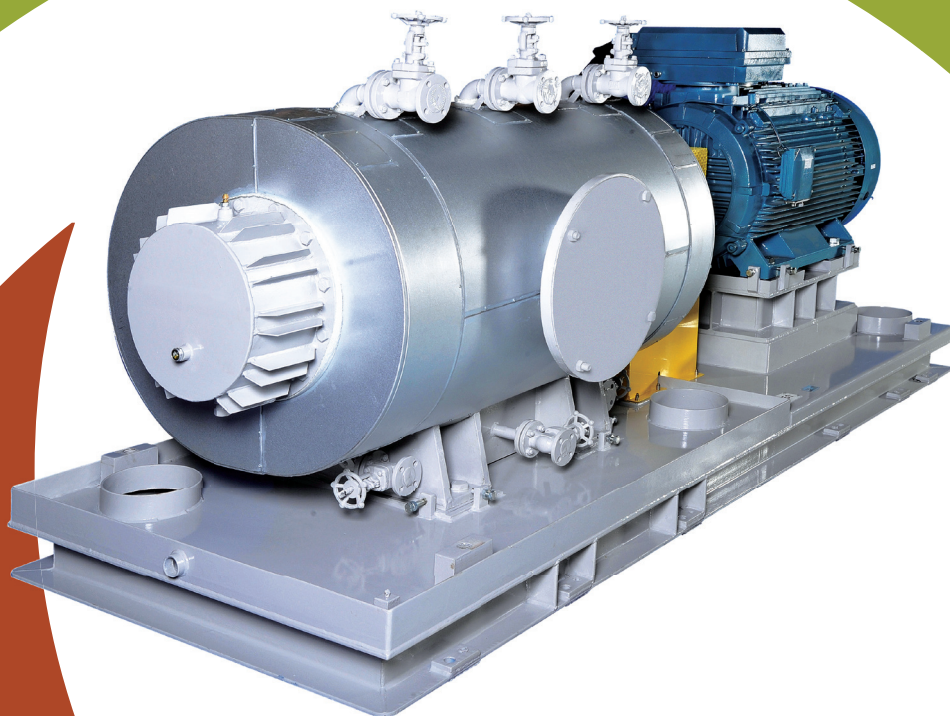

TWINRO TWIN SCREW PUMPS



With decades of experience in designing and manufacturing rotary positive displacement pumps, Celeros Flow Technology's Plenty Mirrlees Pumps have built an excellent reputation for reliable pumping equipment for the marine, oil processing, petrochemical processing, power generation, defense, sugar and general industries. With Plenty Mirrlees Pumps, Celeros Flow Technology has a solution for most pumping applications with a range that includes two screw (TWINRO), three screw (TRIRO) and our 2000 series vane pumps incorporating the unique variable flow feature.

TWINRO - TWIN SCREW PUMPS

Plenty Mirrlees Twinro 'W' Series pumps from Celeros Flow Technology are positive displacement rotary twin screw pumps designed for bulk transfer of liquids. The Twinro series is available in five frame sizes with a selection of different pitch screwsets to match system flow requirements at 50Hz or 60Hz direct electric motor speeds. Pumps may also be driven at other speeds from diesel engines or other prime movers. The material and design options available enable the pump to be offered for most bulk liquid transfer duties across many industries. In particular, the pumps are used extensively in bulk loading and unloading duties in the Oil, Marine, Power Generation and Chemical industries.

Flows up to; 500 m³/hr
(800m³/hr on request for
special applications)

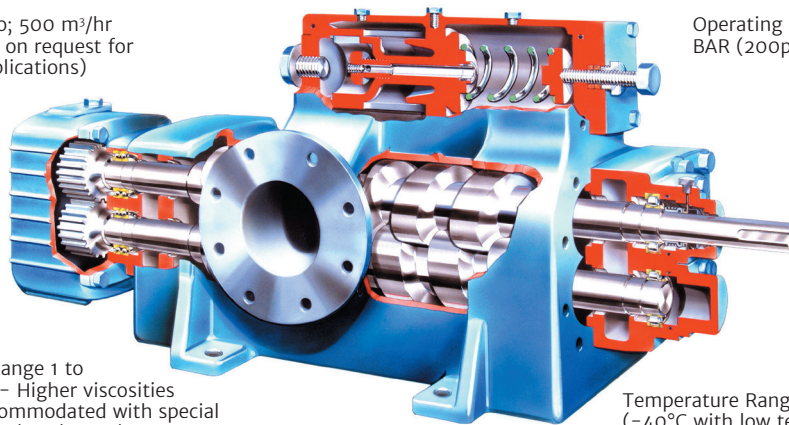

Operating Pressure up to : 14
BAR (200psi) W80 to W375

Viscosity Range 1 to
7000 CST - Higher viscosities
can be accommodated with special
seals and reduced speed

Temperature Range : -10 to +200°C
(-40°C with low temperature
steel construction)

DESIGN AND CONSTRUCTION

- Outboard Bearing Pumps: (for non lubricating liquids) are equipped with four mechanical seals keeping the bearings and timing gears external from the pumped liquid. Drive end roller bearings are grease packed, sealed for life. An oil bath is provided at the non drive end for splash lubrication of the timing gears and ball bearings.
- Inboard Bearing Pumps: (for lubricating liquids) are provided with one mechanical seal on the drive shaft only. The liquid being pumped lubricates the bearing and timing gears.

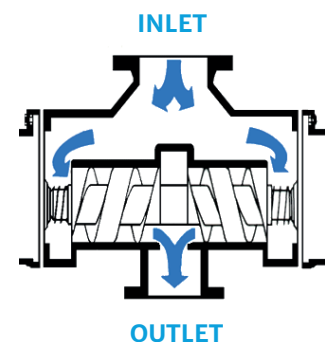

TYPICAL PUMP SECTIONAL DRAWING

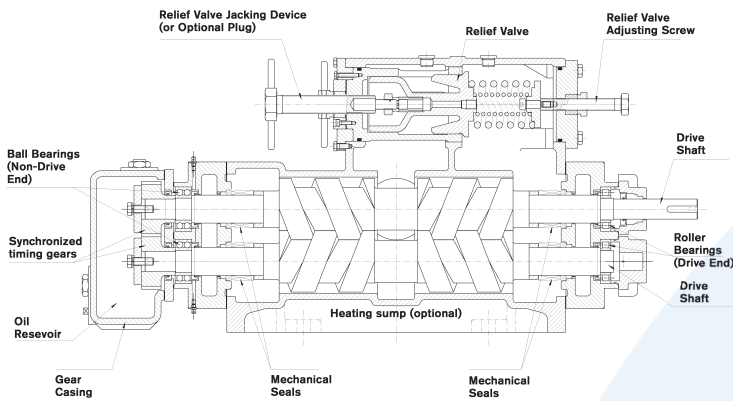

TYPICAL PRODUCT APPLICATIONS

- Relief Valve Design Operation: The valve is of the disc type with an attached dashpot and spring. Under normal operation a very small proportion of liquid from the pump discharge leaks past the clearances between the skirt and cylinder (Fig 1). To prevent pressure building up the liquid drains back to suction through orifice 'O'. Under pressure build up, the relief valve starts to open against the spring, exposing slot 'S' to discharge pressure (Fig 2). This allows the pressure to enter area 'A' and quickly complete the opening of the relief valve to fully bypass the flow. When the pressure drops, the spring pushes the disc back on the seat forcing the liquid in area 'A' back through slot 'S'. When the slot 'S' is completely blanked off by the cylinder wall, all the liquid is constrained to flow back through orifice 'O'. This constraint has a dampening effect which prevents the relief valve slamming onto its seat.
- Rapid Opening, Controlled Damped Closing



Pipeline and Process Flow Requirements



Ships Bunkering



Ships Liquid Cargo Pumping



Ballast Water Management



Distribution in Liquid Marketing Terminals



Tank to Tank Transfer / Tank to Process Transfer (and process to tank transfer)

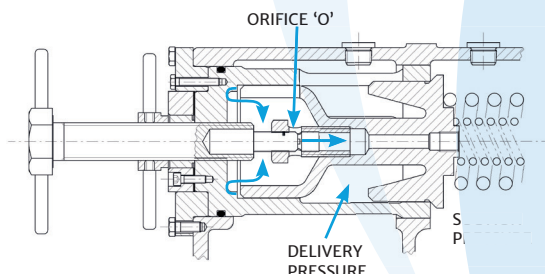
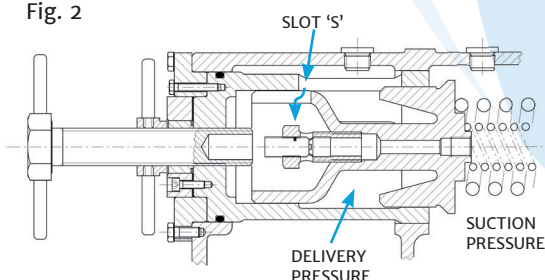

Fig. 2



LIQUID PUMPED

- Lubricating Oils
- Fuel Oils (residual and distillate)
- Petroleum Liquids
- Bitumens/Asphalts
- Solvents/MTBE
- Vegetable Oils
- Glue, Varnish, Resins, Paints, Polymers
- Palm Oils
- Fatty Acids
- Water (fresh or sea)
- Some Acids
- And many others...



Custom Designed Vertical Twin Screw Pump



Standard design horizontal Twin Screw Pump



Numerous Twinro pumps installed at a fuel oil terminal in the UAE



PRODUCT BENEFITS AND FEATURES

- Accurate screw profile (High volumetric efficiency) Low running cost
- No contact between intermeshing screws Can handle lubricating or non lubricating liquids. Very low wear.
- Double suction. End suction / center discharge, on screwset. (Screwset in hydraulic balance) Smooth axial pulse free flow
- Choice of screwset pitch ang Wide flow range
- Individual pitch selection For precise flow rate matching
- Various Mechanical Seal Options Customer choice of mechanical seal and seal type for plant standardization. Elastomer Bellows / Positive Drive Standard Component or Cartridge Design
- Full flow relief valve. Dashpot design (Rapid opening, damped closing) No destructive pressure surges. Added safety. Smooth operation. Lower power Single Row Sealed Ball Bearing
- Fully machined one piece fabricated baseplate Optimum strength. Minimum distortion. Accurate couplin alignment maintained
- Drip rim and grout facility Ease of installation. Maintenance flexibility
- Heating sump (for oil or steam) Maintains hot liquid at required temperature. Prevents cold start damage
- Liquid weir in suction port chamber Maintains wetted screwset for dry start
- Option of seal face lubrication for dry running start Reduce risk of seal face heat damage on dry running start
- Dry start and stop running (limited time) To enable full unloading and loading cycles to take place
- Self priming Can evacuate air from suction lines
- Screw form and shaft, one piece construction Maximum accuracy. Minimum deflection from high discharge pressure

CONSTRUCTION FEATURES - STANDARD CONSTRUCTION (SC) AND SPECIAL ORDERS (SO)

• Casing and Covers	SC: Cast Iron/Cast Steel SO: S.G. Iron/Stainless Steel
• Mounting Orientation	SC: Horizontal Foot Mounted SO: Vertical Free Standing
• Screwset	SC: Carbon Steel SO: Stainless Steel
• Relief Valve	SC: Integral with Pump SO: Blanked off (for System Relief Valve) Relief Valve Jacking Device
• Baseplate	SC: Fabricated Steel SO: Drip Rim Drain and Grout facility on steel base
• Coupling	SC: Flexible 140mm Spacer Type SO: Flexible 180mm Spacer Type Non-Spacer
• Coupling Guard	SC: Aluminum SO: Steel/Brass
• Paint Finish	SC: Standard Industrial System SO: Two pack epoxy or other systems for hostile and offshore environments
• Testing	SC: Standard Works Pressure and Performance Tests SO: Witnessed Tests Noise and Vibration Tests NPSH Test, Custom Tests Plotted Test Curves

Customer/project specific options available upon request



Complete customised pump unit for an oil refinery in India

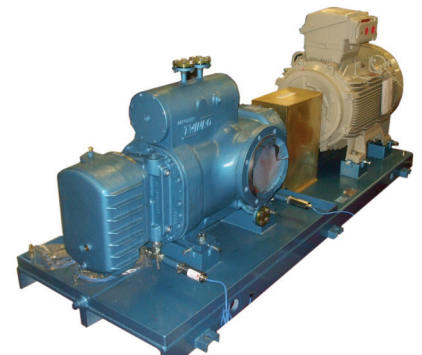

Used for tank to tank transfer in an oil storage terminal

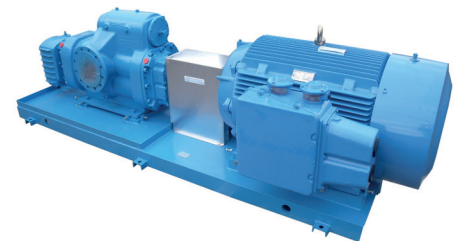

Twinro pump for rail car loading and unloading

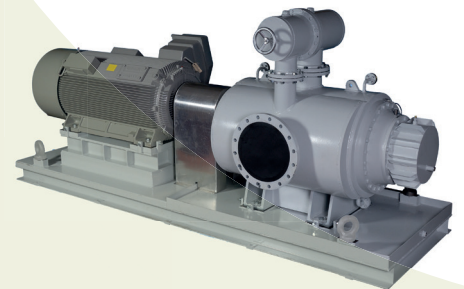

Large flow Twinro for ship loading / unloading

- **Relief Valve Jacking Device:** As an option, Twinro pumps can be fitted with a jacking device to manually lift the relief valve off its seat. This has the operational advantage of being able to circulate pumped liquid around the pump to aid extreme discharge or suction conditions. The device has proved extremely useful in aiding cold start conditions where the liquid in the discharge line is below normal pumping temperature. Another useful application is the partial circulation of discharge liquid back to suction to aid high suction lift applications at the end of barge or tank emptying.
- Operation of the jacking device does not alter pre-set relief valve spring pressure

TECHNICAL DATA - FLOW RANGE

Pump frame size is nominal design flow in m³/hr e.g. W80 is nominally an 80m³/hr pump

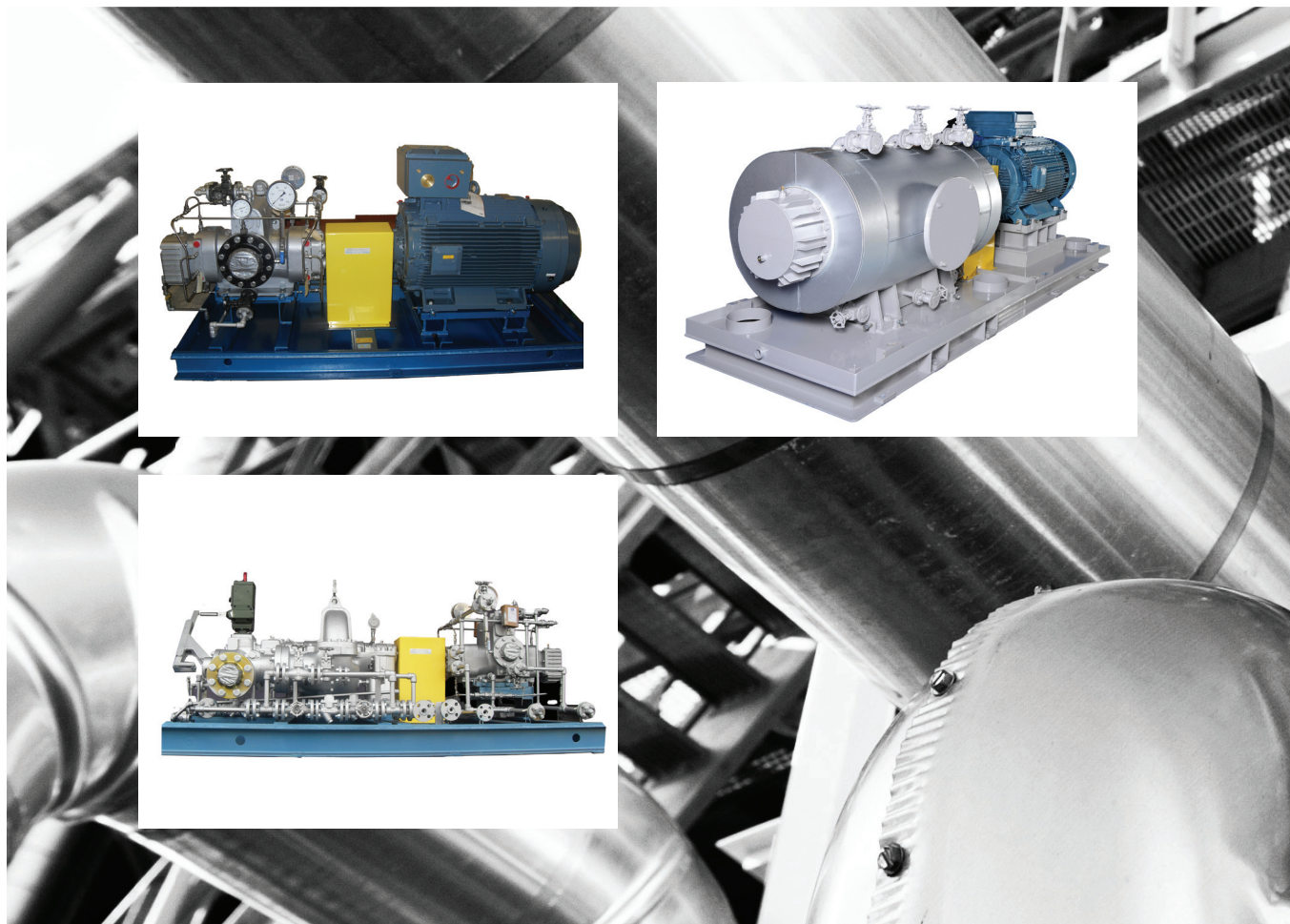
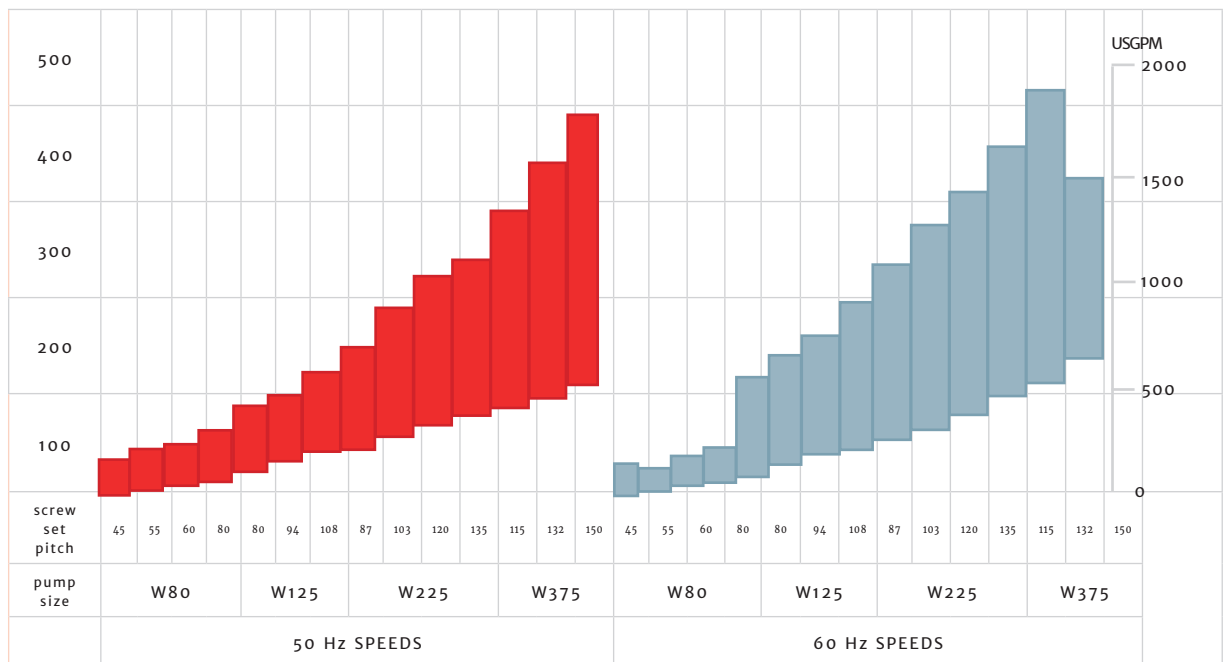

TECHNICAL DATA

(Approximate Dimensions)

	W80	W125	W225	W375	STANDARD FLANGES ARE TO ANSI DIMENSIONS IRON - ANSI 125FF, STEEL - ANSI 150RF DIN PN16 FLANGES ARE ALSO AVAILABLE
SUCTION	4"	6"	8"	10"	
DISCHARGE	4"	6"	8"	8"	

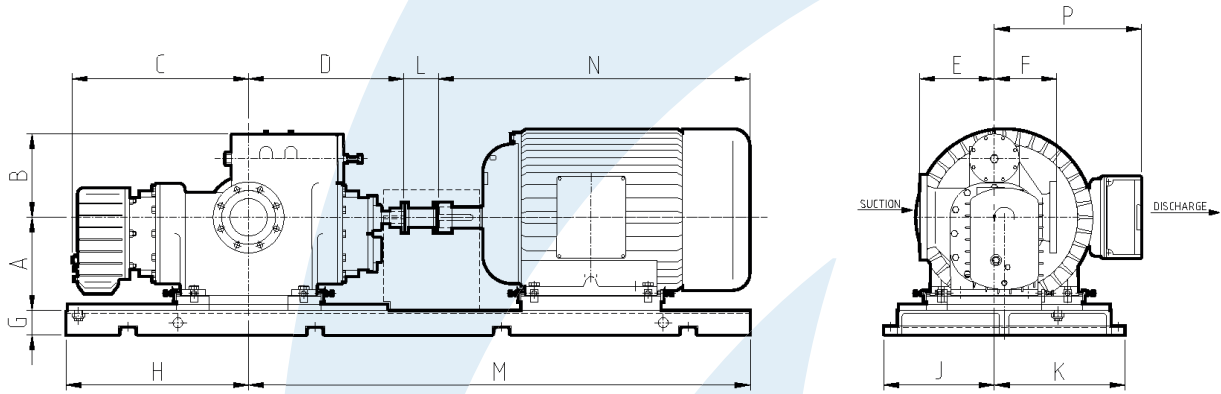

Pumps can be constructed with suction left (as shown) or suction right, to suit installation

Approximate dimensions (mm). DO NOT USE for installation purposes

PUMP SIZE	PUMP ONLY						UNIT					*ELECTRIC MOTOR			
	A	B	C	D	E	F	G	H	J	K	L	FRAME	M	N	P
W80	230	260	510	490	195	165	100	550	185	245	140	100L	1080	394	266
												250L	1430	947	520
W125	290	290	570	555	230	200	100	625	400	460	140	132M	1190	505	319
												280S	1590	1032	543
W225	370	345	709	621	300	250	100	775	380	480	140	160L	1440	650	356
												315M	1940	1253	585
W375	415	386	767	739	348	298	100	775	380	480	140	180L	1640	710	393
												315M	1940	1253	595

* Dimensions are given for the smallest and largest motor sizes for each pump





TWINRO TWIN SCREW PUMPS

- | SPEED
- | EXCELLENCE
- | PARTNERSHIP

 PLENTY