



FUEL MANAGEMENT SYSTEMS



DISPENSERS



KITS



PUMPS



METERS



NOZZLES

EX140 DRUM

FEATURES

- CONTINUOUS DUTY
- THERMAL PROTECTION
- SUCTION UNIT WITH INTEGRATED FILTER
- BUILT-IN BYPASS VALVE
- UL VERSION AVAILABLE

The entire new EX line is characterized by a high flow rate that works with a continuous duty cycle, and has been designed to be particularly suitable for Heavy Duty, i.e. for those demanding fleets that need to dispense fuels such as Gasoline, diesel or kerosene quickly. The PIUSI EX140 DRUM is ATEX certified and complies with the directives on the use of materials in potentially explosive atmospheres.



PERFORMANCE

UP TO
140 L/MIN

FLOW RATE

AC
VOLTAGE

POWER



EX140 DRUM /A140/K150/5MT



EX140 DRUM /A140/5MT

OUR PUMPS COMPLIES WITH THE FOLLOWING MARKING ATEX/IECEx

II	2	G	Ex	d	IIA	T4	Gb
GROUP	CATEGORY	TYPE OF EXPLOSIVE ATMOSPHERE	PERMANENT PREFIX	PROTECTION METHOD	GAS GLASS	TEMPERATURE CLASS	EQUIPMENT PROTECTION LEVEL

PACKAGING

CODE	WEIGHT		PACKAGING		
	KG	LBS	MM	INCH	PCS/BOX
FO0396010	25	55	240X400X350	10X16X15	1
FO0396030	25	55	240X400X350	10X16X15	1
FO0396020	25	55	240X400X350	10X16X15	1
FO0396300	30	66	400X600X430	16X24X17	1
FO0396320	30	66	400X600X430	16X24X17	1
FO0396340	30	66	400X600X430	16X24X17	1
FO0396310	32	70	400X600X430	16X24X17	1
FO0396330	32	70	400X600X430	16X24X17	1
FO0396350	32	70	400X600X430	16X24X17	1



FILTRATION



TANK MONITORING



HOSE REEL



ACCESSORIES



MERCHANDISE



AIR



ANTIFREEZE



AdBlue®



BIODIESEL



DIESEL



FOOD



GASOLINE



GREASE



KEROSENE



OIL



WATER



WINDSCREEN

CHART

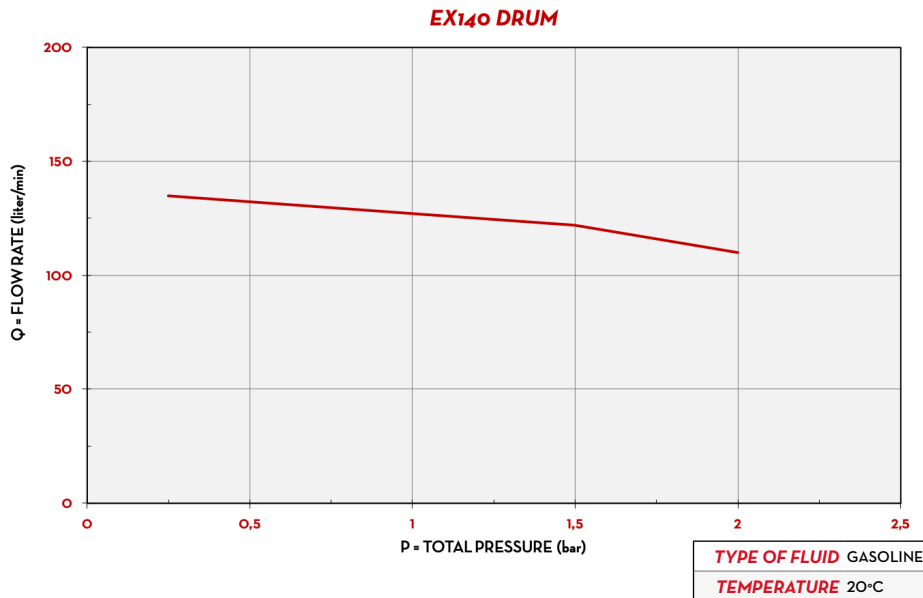

DIMENSIONS

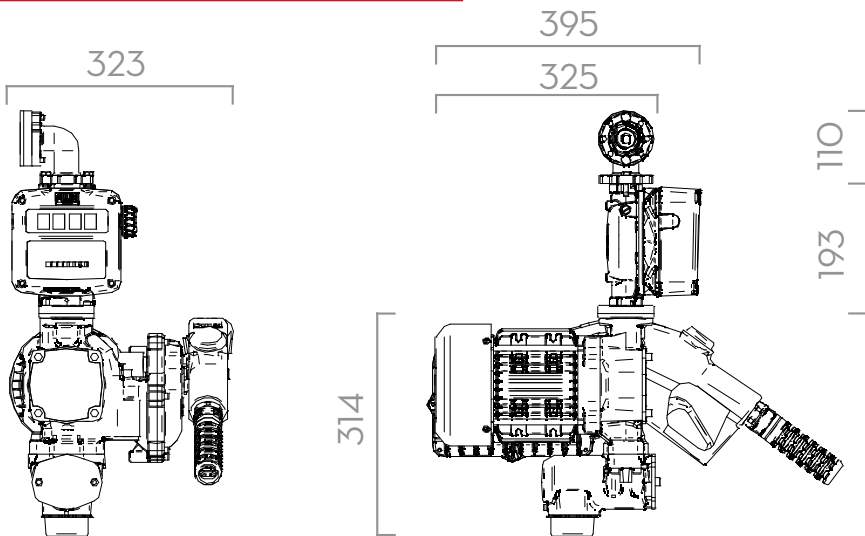

Dimensions expressed in millimeters

IN THE BOX

- EX140 PUMP
- NOZZLE HOLDER
- 2" CONNECTOR
- 90° FLANGED ELBOW
- K150 ATEX METER (ON SELECTED VERSION)
- A140 ATEX AUTOMATIC NOZZLE (ON SELECTED VERSION)
- DELIVERY HOSE (ON SELECTED VERSION)
- INSTRUCTION MANUAL

DETAILS

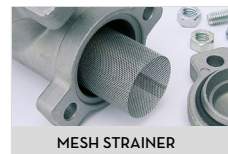

COMPONENTS

- **PUMP:**
EX140 PAG. 98
- **METER:**
K150 ATEX PAG. 130
- **NOZZLE:**
A140 ATEX PAG. 156

TECHNICAL DATA

CODE	DESCRIPTION	FLUIDS TYPE	FLOW RATE		VOLTAGE			DUTY CICLE CONTINUOUS	INLET	OUTLET	METER	DELIVERY HOSE	BENDING PROTECTION	ULTRA HI-FLOW AUTO NOZZLE
			L/MIN	GPM	AC V./HZ	POWER WATT	AMP. MAX.							
FOO396010	(EX) EX140 DRUM 230V/50HZ (PUMP ONLY)	D G K	140	37	230/50	1150	5	YES	2" BSP	1" BSP	-	-	-	-
FOO396030	(EX) EX140 DRUM 230V/60HZ (PUMP ONLY)	D G K	140	37	230/60	920	4	YES	2" BSP	1" BSP	-	-	-	-
FOO396020	(EX) EX140 DRUM 250V/50HZ (PUMP ONLY)	D G K	140	37	250/50	1125	4,5	YES	2" BSP	1" BSP	-	-	-	-
FOO396300	(Ex) EX140 DRUM 230V/50 /A140/5MT	D G K	140	37	230/50	1150	5	YES	2" BSP	1" BSP	-	D.25 5MT	YES	A140
FOO396320	(EX) EX140 DRUM 230V/60 /A140/5MT	D G K	140	37	230/60	920	4	YES	2" BSP	1" BSP	-	D.25 5MT	YES	A140
FOO396340	(EX) EX140 DRUM 250V/50 /A140/5MT	D G K	140	37	250/50	1125	4,5	YES	2" BSP	1" BSP	-	D.25 5MT	YES	A140
FOO396310	(EX) EX140 DRUM 230V/50 /A140/K150/5MT	D G K	140	37	230/50	1150	5	YES	2" BSP	1" BSP	K150	D.25 5MT	YES	A140
FOO396330	(EX) EX140 DRUM 230V/60 /A140/K150/5MT	D G K	140	37	230/60	920	4	YES	2" BSP	1" BSP	K150	D.25 5MT	YES	A140
FOO396350	(EX) EX140 DRUM 250V/50 /A140/K150/5MT	D G K	140	37	250/50	1125	4,5	YES	2" BSP	1" BSP	K150	D.25 5MT	YES	A140

() UPON REQUEST IT IS AVAILABLE WITH DIFFERENT VOLTAGES AND 60 HZ FREQUENCY. COMPATIBLE FLUIDS: DIESEL, KEROSENE, PETROL, PETROL ALCOHOL MIXED MAX 15%, AVGAS 100/100LL, JET A/A1 - ASPEN 2/4

EX140 DRUM