

Semi-automatic top labeling

Versatile and precise

Optimal results with maximum flexibility: That's what the semi-automatic top labeler 414 has to offer. This highly compact top labeler with the innovative and powerful HERMA 500 and precise label transfer unit is capable of labeling products with a wide variety of shapes.

Best results on flat surfaces as well as surfaces with raised or recessed areas are guaranteed.

For efficient, precise top labeling of small batches, the product is manually inserted into a product holder. It fixes the product during labeling. The moving peel plate then moves the label under the tamp pad of the transfer unit. Once the label has been sucked by the tamp pad, it is precisely applied to the product by the linear transfer unit.

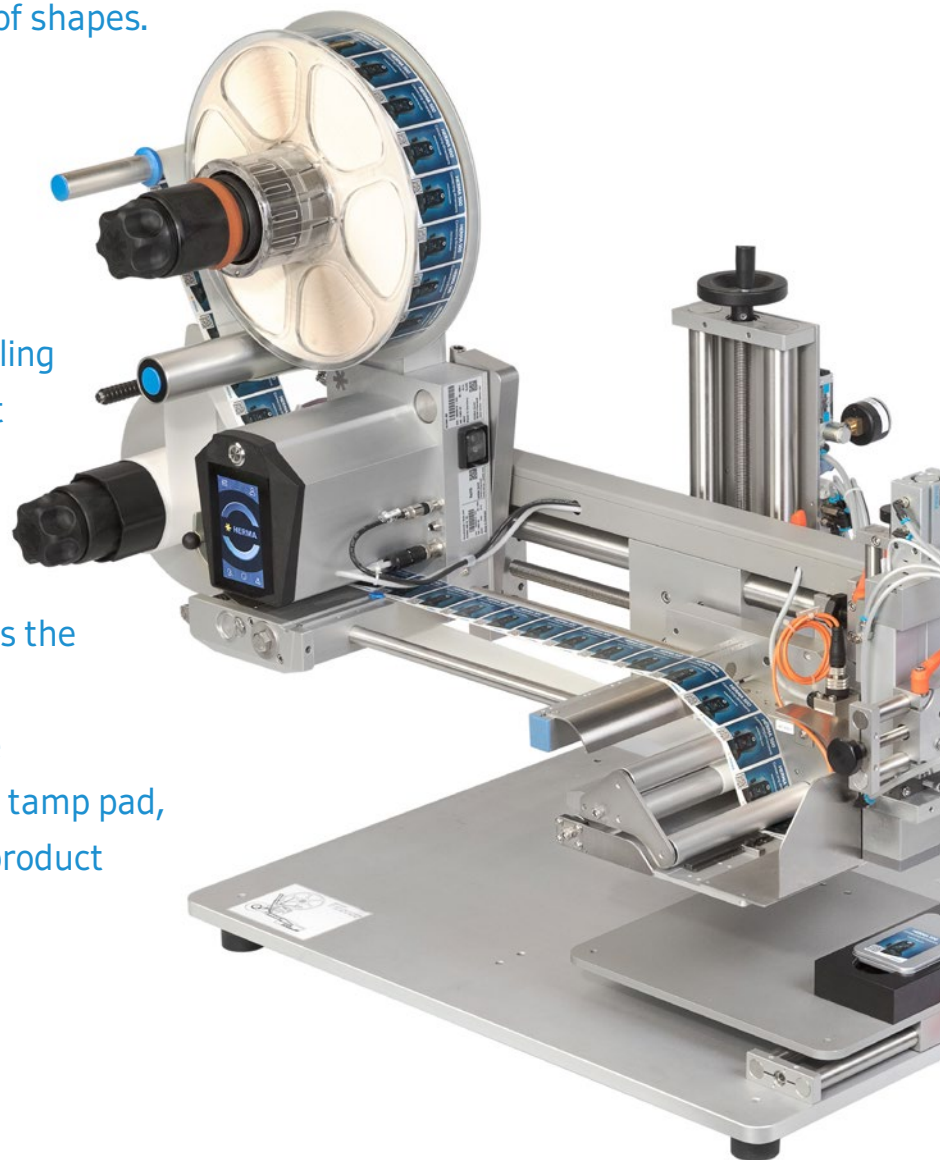

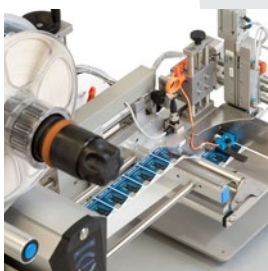

Benefits at a glance

- Precise semi-automatic top labeling for a wide variety of formats as well as flat and curved surfaces
- High-performance applicator HERMA 500 with integrated machine control and convenient adjustment of all parameters via the integrated touchscreen
- On request, different printers can be integrated to print variable data

Technical data

Labeling type:	Top labeling, for manual insertion/removal of products
Product specifications:	Rectangular, oval, cylindrical, horizontal, largely stable in form
Product dimensions:	20 - 300 x 20 - 300 x 1 - 280 mm (L x W x H)
Label dimensions:	15 - 160 x 10 - 100 mm (W x L)
Capacity:	Up to 20 products/minute
Power supply:	100 - 240 V, 50 - 60 Hz, 1 phase
Compressed air supply:	6 bar
Printer:	Various hot-foil and thermal transfer printers (optional)
Components:	Applicator with moving peel plate, linear transfer unit with holder for tamp pad, foot switch for label start signal
Options:	Product attachment plate, product holder, label web stopper, pick-up cylinder, tamp pad, digital position indicators, two-hand control for label start signal
Note:	If optional features are chosen, the above data may vary

