

# Ruelco

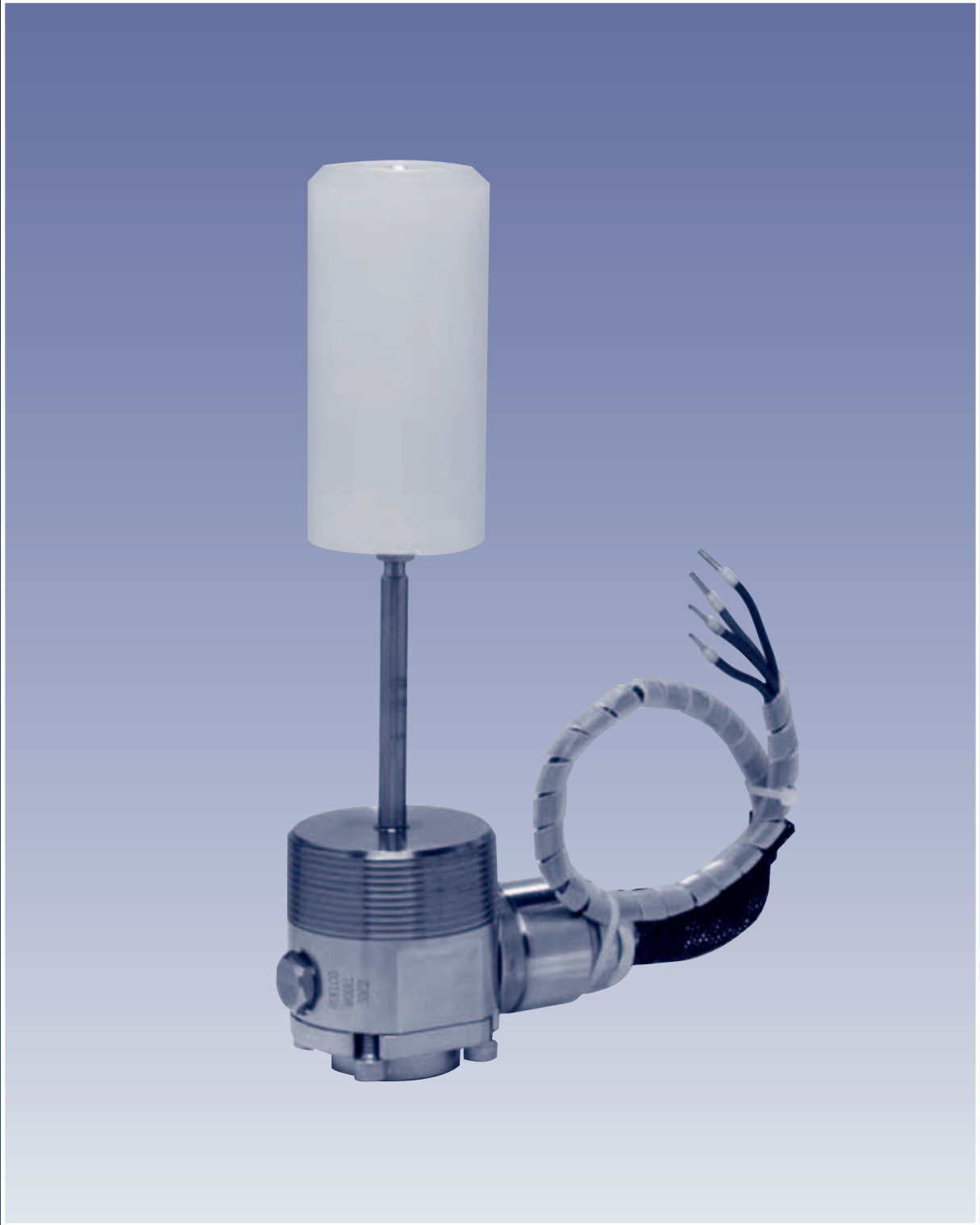

**Flex-Level Switch**

**Model 38C2**

# Model 38C2 Manufactured Under U.S. Patent # 4838303

## Flex Level Switch

### FEATURES

- Uses hermetically sealed, snap acting, dry contact switches rated explosion proof (U.L.™ rated Class I, Div. I Groups A, B, C, D).
- Atmospheric vent between level sensor process seals and switch assembly.
- 2" NPT threaded mounting.

### OPTIONS

- SPDT or DPDT switches.
- 0.4 specific gravity operation.
- Hangdown displacers for easy top mounting on vessel with 1-1/2" to 4" connections using standard pipe fittings.
- 316 S.S. displacer for operating temperatures to 450°F (232°C).
- External manual test mechanism.
- Rating for Cenelec EExdIICT6.

### GENERAL DESCRIPTION:

The Ruelco Model '38C2' meets the growing industry demands for durable, easy to maintain and accurate electrical discrete point level indication. Its non-externally adjustable set point makes it ideal for level safety switches and redundant back-up switches for simple local control to the most sophisticated process control systems. The direct action of the "Flex-Level" design ensures trouble free operation in the process fluids with specific gravities as low as 0.6 without any fine tuning or other adjustments.

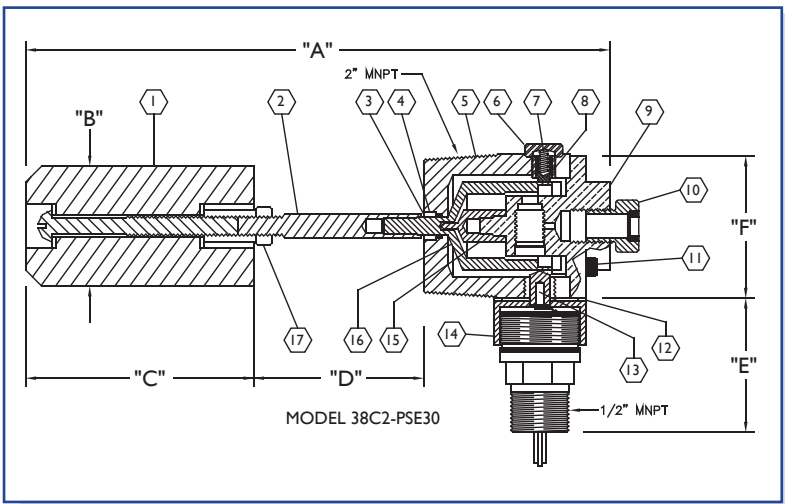

### Parts List For Flex Level Switch 38C2

Item	Qty.	Description	Material	Part No.
1	1	Standard Displacer	Polypropylene	30-016-000
1	-	St. Stl. Displacer	316 St. Stl.	30-068-000
2	1	Float Rod	316 St. Stl.	30-005-0A0
3	1	Body Seal Retainer	316 St. Stl.	30-007-0A0
4	1	Body Seal	Fluorocarbon	V0-008-75H
5	1	Body	316 St. Stl.	30-001-0B0
6	1	Spring Cap	316 St. Stl.	30-012-000
7	1	Spring	Inconel X-750	30-014-000
8	1	Spring Guide	316 St. Stl.	30-008-001
9	1	Cast Pivot Valve Body	316 St. Stl.	30-064-000
10	1	Vent Plug	316 St. Stl.	91-002-000
11	4	Socket Head Cap Screw	316 St. Stl.	T8-08K-0G3
12	1	Support Washer	316 St. Stl.	38-020-000
13	1	Push Rod Assembly	Acetal/ 18-8 SS	38-022-000
14	1	SPDT Switch Assembly	316 St. Stl.	38-018-000
14	-	DPDT Switch Assembly	316 St. Stl.	38-019-000
15	1	Pivot	17-4 PH St. Stl.	30-079-000
16	1	Cone	17-4 PH St. Stl.	30-085-000
17	1	Float Rod Nut	316 St. Stl.	T6-08K-073
18	-	Repair Kit	Item 4 & 15	38-016-000

### Ordering Code: 38C2 X X X E X X

Base Model Number	Standard Model	To N.A.C.E. MR0175	Polypropylene Displacer	316 St. Stl. Displacer (2160 psi W.P.)	SPDT Electrical Switch	DPDT Electrical Switch	Std. Rod with Horiz. Displacer	6" Rod with Horiz. Displacer	Horizontal Displacer	1" to 10" Hangdown
38C2 2" NPT Electric	-	N	P	6	S	D	3	6	0	3

### Specifications

Max. Test Pressure PSI (BAR) @ 100° F (37° C)	3240 (223)	Max. W.P. PSI (BAR) @ 100° F (37° C)	2160 (149)	Ambient Temperature Range	-20° to 161° F -20° to 72° C	Max. Process Fluid Temperature	200° F* (93° C)	Min. Specific Gravity	.6	SPDT & DPDT Max. AC/DC Voltage	250 AC 30 DC	SPDT & DPDT AMPS @ Rated Voltage	5 AC/DC
--	---------------	---	---------------	------------------------------	---------------------------------	-----------------------------------	--------------------	-----------------------	----	-----------------------------------	-----------------	-------------------------------------	------------

\* 450° F (232° C) w/ St. Stl. Displacer

### Dimensions In. (mm)

"A"	10.06 (255.5)
"B"	2.00 (50.8)
"C"	4.10 (104.14)
"D"	3.25 (82.6)
"E"	2.37 (60.2)
"F"	2.25 (57.2)
"G"	1/2" MNPT
Weight	3.8 Lbs (1.7 Kg)