

# MEDENUS

Gas Pressure Regulation



## Gas pressure regulator RS 250 / RS 251

Product information

EN



## Table of Contents

<b>Application, Characteristics, Technical Data</b>	<b>4</b>
Application	4
Characteristics	4
Type of model (options)	4
Technical Data	5
Design and function	6
Option	8
$K_G$ * value and control units	10
Integrated safety relief valve (Leakage gas SRV)	10
Accuracy class AC / Closing pressure group SG	11
Control unit setpoint spring table	12
Control unit setpoint spring table	13
Setpoint spring table - SSV	14
Setpoint spring table - SSV	15
<b>Dimensions, Connection and Weight</b>	<b>16</b>
Dimensional drawing	16
Installation situation	16
Dimensions and weight	17
RS 250: Connection of the measuring lines and breather lines	18
RS 251: Connection of the measuring lines and breather lines	18
<b>Selection</b>	<b>18</b>
Calculation of the required $K_G$ value	18
Device selection	18
Checking the gas velocities	19
<b>Order data</b>	<b>20</b>
<b>Contact</b>	<b>22</b>
<b>Notes</b>	<b>24-26</b>

### List of abbreviations and formula symbols

AC	Accuracy class	PS	Maximum allowable pressure	$W_{dsu}$	Lower adjustment range (SSV)
$AG_o$	Upper response pressure group	$p_u$	Inlet pressure	$\Delta p_{wo}$	Min. re-engagement difference between upper response pressure and normal operating pressure
$AG_u$	Lower response pressure group	$Q_n$	Standard volumetric flow rate		
HDS	High-pressure screw spindle value	RE	Control unit	$\Delta p_{wu}$	Min. re-engagement difference between lower response pressure and normal operating pressure
$K_G$		BV	Breather valve		
$p_d$	Outlet pressure	RSD	Throttle valve		
$p_{df}$	SRV closing pressure	RSS	Switching valve		
$p_{do}$	SRV opening pressure	SSV	Safety shut-off valve		
$p_{ds}$	Setpoint of the response pressure	SRV	Safety relief valve	$\rho_n$	Gas density
$p_{ds o}$	Upper SSV response pressure	SG	Closing pressure group		
$p_{ds u}$	Lower SSV response pressure	$t_{Gas}$	Gas inlet temperature		
$p_{f,max}$	Maximum closing pressure	VS	Valve seat		
		$w_d$	Outlet gas velocity		
		$w_u$	Inlet gas velocity		
		$W_{dso}$	Upper adjustment range (SSV)		

\*)  $K_G$  value for natural gas:  $d = 0,64$  ( $\rho_n = 0,83 \text{ kg/m}^3$ ),  $t_u = 15^\circ \text{ C}$

# Application, Characteristics, Technical Data

## Application

Gas pressure regulator (GDR), direct-acting (operating without auxiliary power), for systems acc. to DVGW - work sheet G 491 (A) and G 600 (A) (TRGI)

Particularly suitable for dynamic regulation sections (e.g. gas fireplaces, natural gas distribution plants, burner, gas engines)

Can be used as an equipment component for gas consumption systems according to Regulation (EU) 2016/426.

Can be used for the gases defined in DVGW - work sheet G 260 / G 262 and neutral non-aggressive gases. (other gases on request)

## Features

- Integral pressure-tight model (IS)
- Gas pressure regulator with integrated SSV
- Easy maintenance through replaceable SSV functional units (modular design)
- SSV functional class, optionally A or B
- outdoor version as standard

## Type of model (options)

- Oxygen model
- Without SSV
- With noise reduction
- With SSV manual release
- With SSV - electromagnetic remote release when power is applied or in case of power failure
- With electric position indicator SSV 'Closed' via inductive initiator or via Reed contact
- Control unit with integrated leakage gas SRV or safety diaphragm
- With BV breather valve for SSV
- With throttle valve (RSD) for impulse line of the regulator
- Coating with epoxy resin in RAL colours

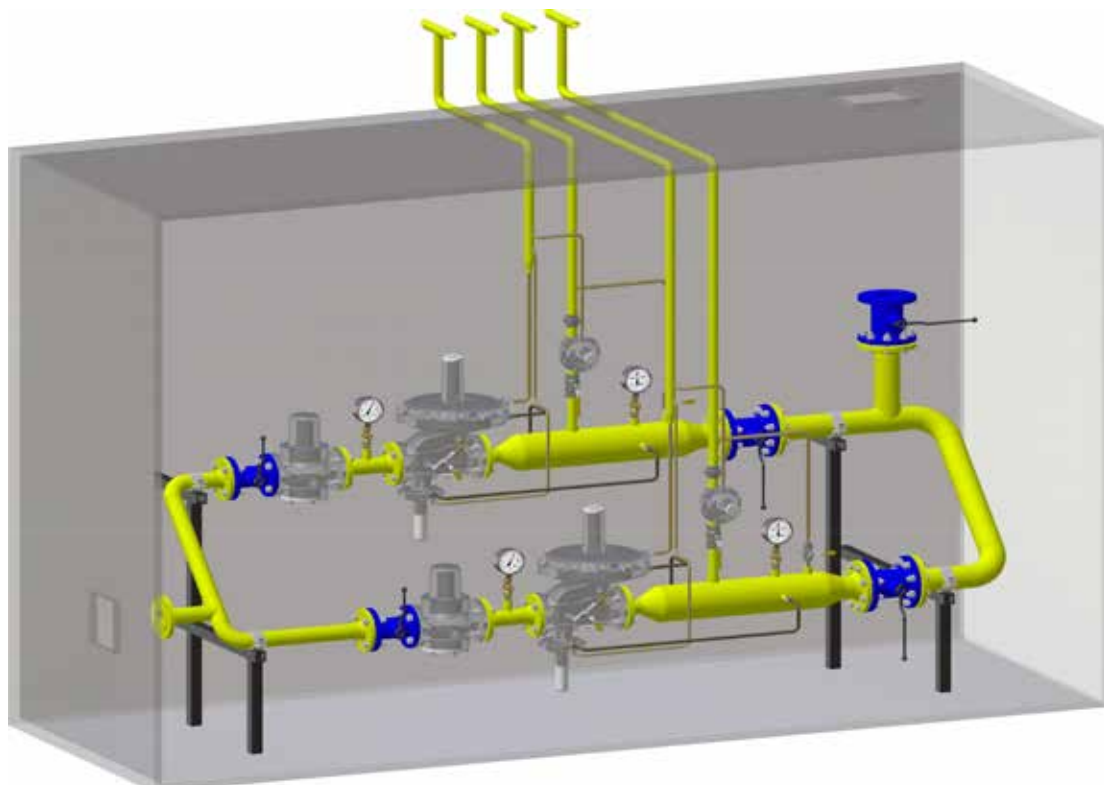

double gas train

## Technical Data

<b>Type</b>	RS 250 / RS 251
<b>Model</b>	Integral pressure-tight (IS)
<b>Max. allowable pressure PS</b>	8 bar
<b>Max. inlet pressure <math>p_{u,max}</math></b>	<b>8 bar</b>
<b>Nominal size</b>	RS 250: DN 25, DN 50, DN 80, DN 100, DN 150, DN 200 RS 251: DN 50, DN 80, DN 100
<b>Connection type</b>	DIN EN 1092 - PN 16 flanges ASME - B16.5 flanges Class 150 RF
<b>Material</b>	
Housing / actuator housing/ Control device housing	Al cast alloy*
<b>Temperature range, Class 2</b> (operating/ambient temperature)	-20°C to +60°C
<b>Closing pressure zone group</b>	<b>SZ 2.5</b>

### Gas pressure regulator

Accuracy class AC and closing pressure group SG at the outlet pressure range $p_d$	AC	SG
18 mbar to 100 mbar	10	20
> 100 mbar to 500 mbar	5	10
> 500 mbar to 1500 mbar	2.5	10
>1000 mbar (only RE 205 / 275)	5	10

### Safety shut-off valve

Upper response pressure group $AG_o$ in command area $w_{dso}$	$AG_o$	Lower response pressure $AG_u$ in command area $w_{dsu}$	$AG_u$
50 mbar to 100 mbar	10	10 mbar to 30 mbar	20
> 100 mbar to 500 mbar	5	> 30 mbar to 50 mbar	10
> 500 mbar	2.5	> 50 mbar	5

**Function, Strength and Tightness** DIN EN 334 and DIN EN 14382

**CE mark to PED/ PIN number** CE-0085-AQ0882 / CE-0085-AQ0883

**Ex protection** The mechanical parts of the device do not have any potential ignition sources of their own and therefore do not fall within the scope of ATEX 95 (94/9/EC). Electrical components fitted to the device comply with the ATEX requirements.

\*) RS 250: DN 50/ DN 80/ DN 100 housing also available in spheroidal cast iron (GJS)

\*\*) Corrosivity category according to DIN EN ISO 12944-2.

The categories C1 to C5-I including guaranteed without additional coatings.  
For the category C5-M a coating with epoxy resin is recommended.



# Application, Characteristics, Technical Data

## Design and function

The spring-loaded gas pressure regulators RS 250 / RS 251 have the function of keeping the outlet pressure of a gaseous medium constant within allowable limit values, independently of the effect of interferences, such as changes in the inlet pressure and/or in the gas train, in the connected regulation section on the outlet side. The gas pressure regulator is composed of the actuator housing and the 'control unit plus actuator' and 'SSV control device/switching device plus actuator' functional units.

The actuator for the control unit can be produced in various valve seat diameters to suit different nominal size. The valve seat models are pre-pressure-compensated and can, if required, be equipped with noise reduction.

The gas flows through the actuator housing in the direction of the arrow. The external measurement line port is used to pass the outlet pressure to be regulated to the bottom of the main diaphragm of the control unit. It compares the actual value with the command variable preset by the force of the setpoint spring. The setpoint required in each case is set via the setting screw. Any deviation from the setpoint is transmitted by the screw spindle to the actuator, which is adjusted such that the actual value is adjusted to the setpoint. In case of zero tap, the actuator will close tight, causing the closing pressure to be established. Optionally, the control unit can be equipped with a leakage gas SRV or a safety diaphragm. In the model with safety diaphragm, the safety diaphragm is located above the main diaphragm. When the main diaphragm ruptures, the safety diaphragm makes contact with the top cover of the control unit and prevents any inadmissible escape of gas into the surrounding atmosphere. In case of inadmissible overpressure or lack of gas in the regulating section, the actuator of the safety shut-off valve arranged in the same housing on the inlet side will shut off the gas flow. To this end, the outlet pressure to be monitored is passed on to the SSV control device via a separate measurement line. As a function of the change in pressure, the SSV diaphragm in the controller is raised or lowered. When the outlet pressure in the regulating section exceeds or falls below a certain response pressure, the switch socket connected to the SSV diaphragm will move to the corresponding disengaging position, the balls of the engaging mechanism will release the SSV screw spindle, and the closing spring will press the SSV valve plate against the valve seat. The SSV actuator shuts off the gas flow gas-tight. The SSV can only be opened by hand and engaged in the open position. To do so, the outlet pressure at the measuring point must be lowered below the upper response pressure or raised above the lower response pressure by at least the re-engaging differential amount ( $\Delta p$ ).

The SSV can, except where otherwise stipulated in specific national legislation, be used in either functional class A (with diaphragm rupture protection) and B (without diaphragm rupture protection).

There is also the option of using a remote indication for the SSV position 'CLOSED' and a manual and remote release when power is applied or in case of power failure.

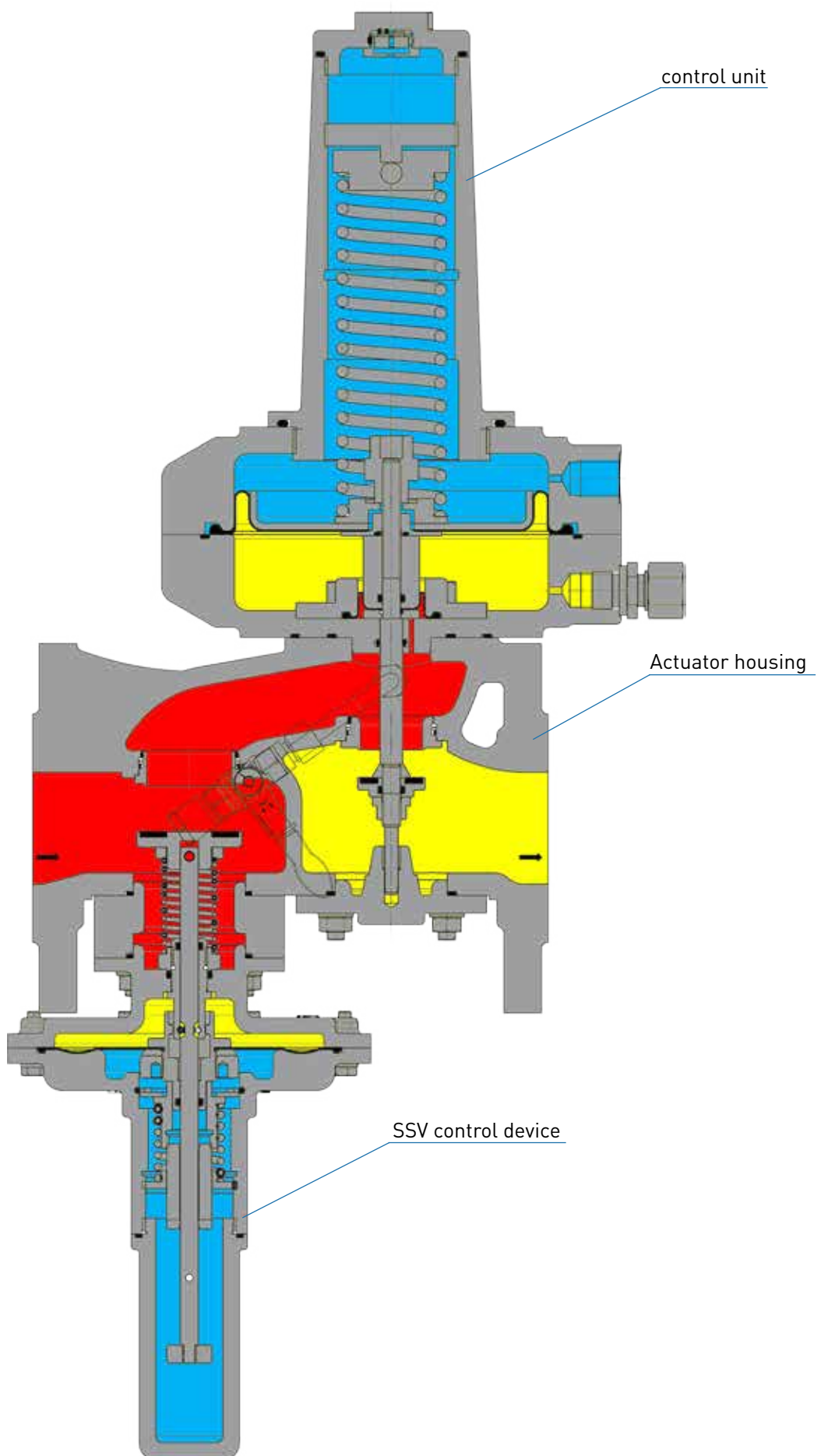

## Options

### Safety diaphragm

The safety diaphragm design provides a safety diaphragm above the main diaphragm. In case the main diaphragm breaks, the safety diaphragm presses against the upper diaphragm cover and prevents leaking into the atmosphere.



### Noise reduction

The noise reduction is made of metal foam and reduces noise of the gas pressure regulator, caused by flow velocity up to -15 dB ( $\pm 3$  dB).



### RSD throttle valve

The RSD is a throttle valve which regulates the volume flow within the measuring line from the outside. This is achieved by a continuously adjustable cross sectional narrowing. The adjustment is made by means of an Allen key (4mm).

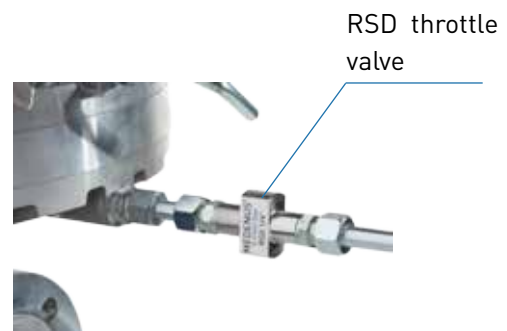

### SAV remote release

The direct-acting solenoid valve serves as an electromagnetic remote release for closing the safety shut-off valve in case of power flow and power failure.





## Breathing valve BV

The breathing valve BV serves to protect the room of installation against inadmissible gas leakage from the venting space of safety shut-off valves.

It is also an alternative to the cost- and work intensive installation of breathing pipes.



Breathing valve BV

---

## Signal transmitter / Inductive Sensor

Signal and inductive sensors are used to monitor the position (closed or open position) of the safety shut-off valve by remote display.

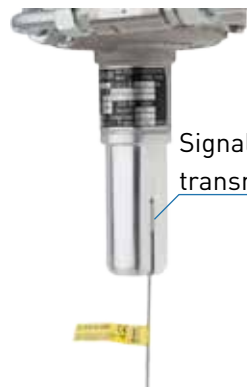

Signal transmitter

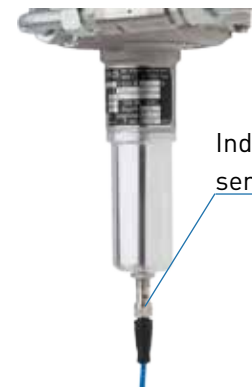

Inductive sensor

## Application, Characteristics, Technical Data

### $K_G^*$ value and control units

Nominal size	RS 250						RS 251		
	DN 25	DN 50	DN 80	DN 100	DN 150	DN 200	DN 50	DN 80	DN 100
control unit $\emptyset$	205	205	205	205	275-2	275-2	205	275-2	275-2
Valve seat $\emptyset$	320	320	275	275	385	385	275	385	385
17.5 mm	200	220							
27.5 mm	420	500	550	600			550		
32.5 mm		750	850	900			750		
42.5 mm			1,450	1,500	1,600		1,250	1,500	1,500
52.5 mm				1,800	2,000		1,700	1,800	1,850
65.0 mm					3,500			2,600	3,200
85.0 mm					4,600			3,500	4,300
95.0 mm					5,800	6,100			4,800
115.0 mm						8,950			
Connection type	DIN EN 1092 - PN16								
	ASME B 16.5 - Class 150								

### Integrated safety relief valve (Leakage gas SRV)

Spring no.	control unit	Opening pressure** Setting via $p_{ds}$ [mbar]
FM 404	275	15 + 5
		30 +10
		60 +15
		90 +15
	320	15 + 5
		30 +10
		60 +15
		90 +15
FM 405		90 +15
FM 404	385 / 390	15 + 5
		30 +10
		60 +15
		90 +15
FM 405	485	15 + 5
		30 +10
		60 +15
		90 +15
FD 919		90 +15

\*)  $K_G$  value for natural gas:  $d = 0.64$  ( $\rho_n = 0.83 \text{ kg/m}^3$ ),  $t_u = 15^\circ\text{C}$

\*\*) When selecting the opening pressure for the leakage gas SRV, the value must not drop below the closing pressure of the setpoint setting!

## Accuracy class AC / Closing pressure group SG

Outlet pressure range $p_d$	control units						
	205	275	275-2	320	385	390	485
18 mbar to 100 mbar				10 / 20	10 / 20	10 / 20	5 / 10
90 mbar to 500 mbar		5 / 10					
100 mbar to 500 mbar				5 / 10	5 / 10	5 / 10	5 / 10
350 mbar to 500 mbar			10 / 20				
500 mbar to 1000 mbar	10 / 20						
> 500 mbar		2.5 / 10	5 / 10	2.5 / 10	2.5 / 10	2.5 / 10	
> 1000 mbar	5 / 10						

# Application, Characteristics, Technical Data

## Control unit setpoint spring table

Specific command range $W_{ds}$ [mbar]				Spring data	
RE 205	RE 275	RE 320	RE 390	Spring no.	Colour [RAL]
36 - 39	23 - 25	10 - 12	8 - 10	FA 01	blank
38 - 45	24 - 28	11 - 13	9 - 12	FA 02	9006
44 - 52	27 - 31	14 - 18	11 - 13	FA 03	5015
51 - 64	30 - 37	17 - 22	12 - 15	FA 04	4002
62 - 81	35 - 46	21 - 29	14 - 19	FA 05	7037
78 - 107	43 - 59	28 - 39	18 - 24	FA 06	9005
103 - 147	55 - 80	38 - 54	23 - 32	FA 07	3020
140 - 205	73 - 110	53 - 77	31 - 45	FA 08	9010
195 - 295	100 - 156	76 - 111	42 - 64	FA 09	7016
280 - 430	141 - 225	110 - 166	59 - 94	FA 10	6010
419 - 653	208 - 339	165 - 250	88 - 142	FA 11	2002
595 - 935	293 - 484	239 - 361	124 - 203	FA 12*	7035
819 - 1408	436 - 726	360 - 544	185 - 305	FA 13*	5010
1245 - 1976	607 - 1017	506 - 765	258 - 428	FA 14*	1028
1212 - 2553	699 - 1333	535 - 978	297 - 568	FA 15*	6018
1330 - 3012	785 - 1580	602 - 1157	333 - 673	FA 16*	3020

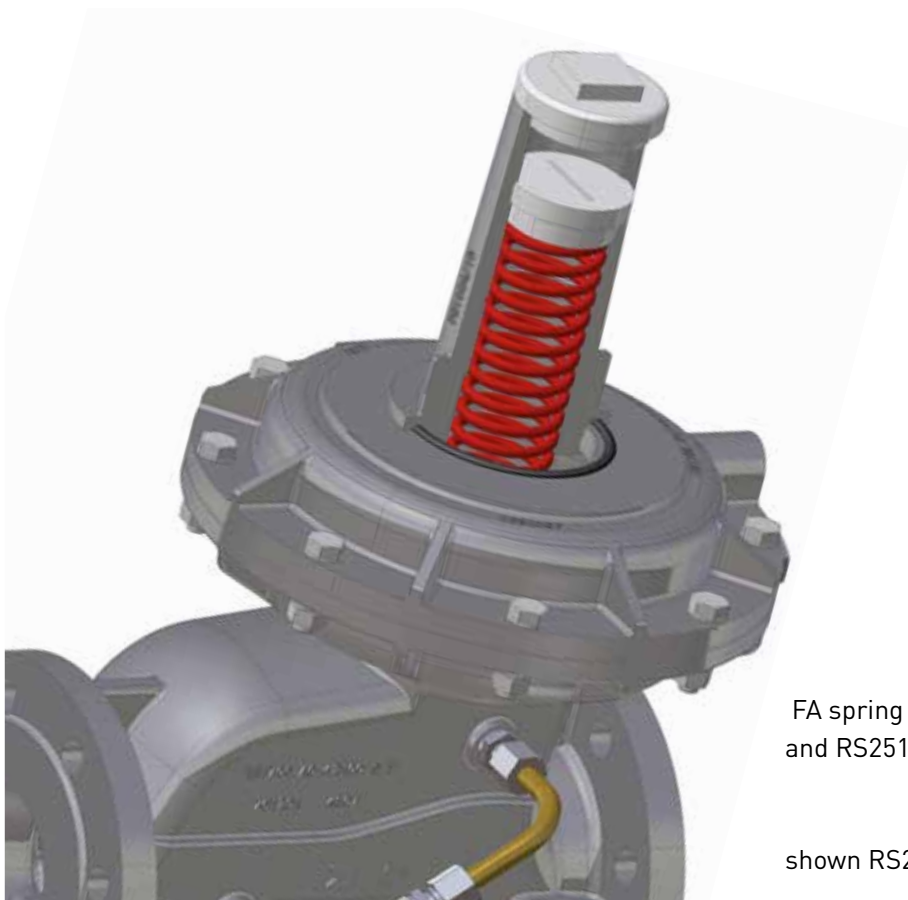

FA spring series for RS250 DN 025 - DN 100  
and RS251 DN 050

shown RS250 DN 080 with FA11

\*) with high-pressure screw spindle (HDS shown on p.14)

## Control unit setpoint spring table

Specific command range $W_{ds}$ [mbar]			Spring data	
RE 275-2	RE 385-2	RE 485	Spring no.	Colour [RAL]
59 - 69	31 - 35	19 - 22	FB 701	6018
68 - 83	34 - 41	21 - 25	FB 702	9006
80 - 105	40 - 51	24 - 31	FB 703	5015
96 - 127	50 - 61	28 - 36	FB 704	4002
112 - 156	60 - 77	33 - 44	FB 705	7037
146 - 207	76 - 100	41 - 56	FB 706	9005
184 - 266	98 - 127	51 - 71	FB 707	3020
238 - 358	125 - 167	65 - 94	FB 708	9010
302 - 450	165 - 215	82 - 118	FB 709	7016
397 - 596	212 - 285	105 - 155	FB 710	6010
542 - 814	280 - 390	140 - 209	FB 711	2002
742 - 1078	385 - 520	188 - 275	FB 712	7035
977 - 1442	515 - 671	246 - 369	FB 713*	5010
1245 - 1878	661 - 873	311 - 479	FB 714*	1028
1547 - 2469	712 - 1186	393 - 618	FB 715*	6018
2136 - 3008	975 - 1514	517 - 752	FB 716*	3020

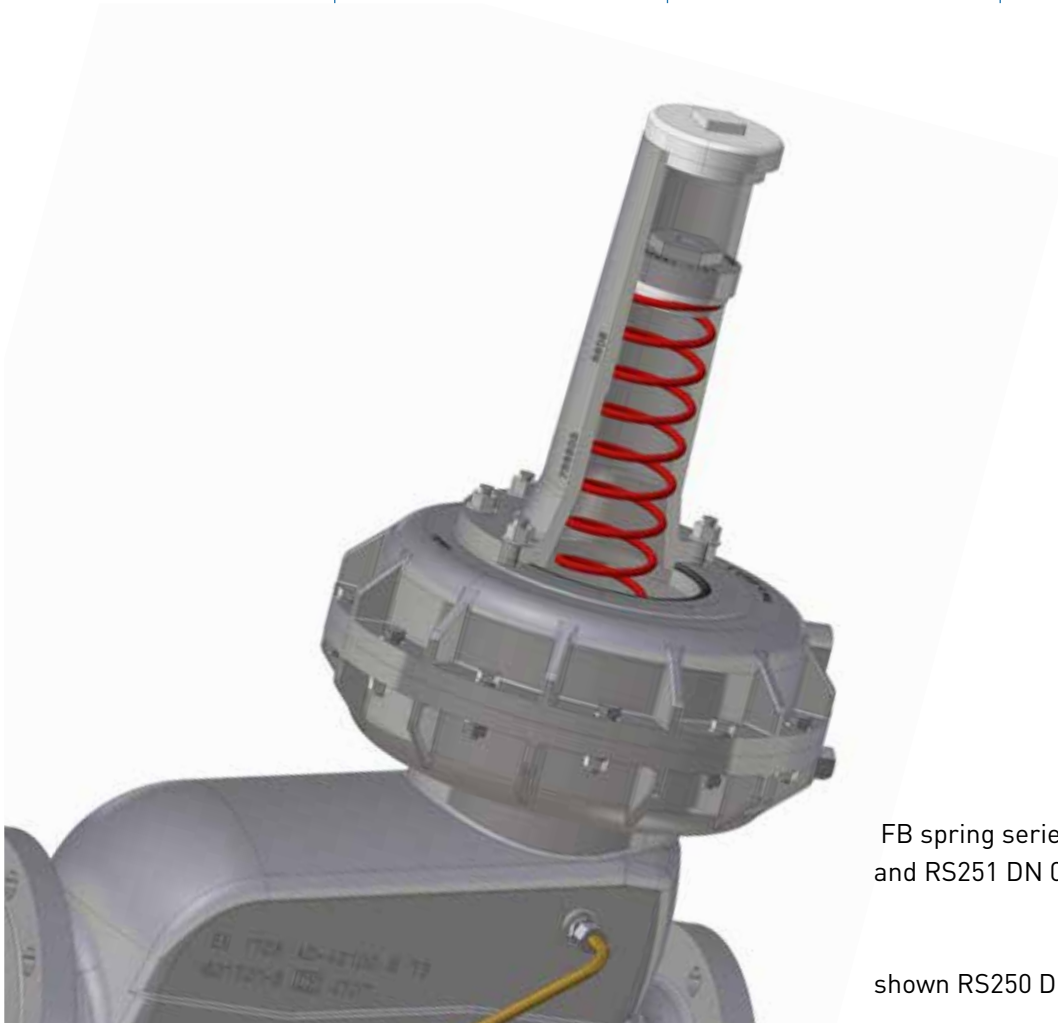

FB spring series for RS250 DN 150 - DN 200  
and RS251 DN 080 - DN 100

shown RS250 DN 200 with FB707

## Setpoint spring table - SSV

		<b>MD</b> small ball lock up to $W_{ds,0}$ 300mbar				<b>MD-R</b> small ball lock up to $W_{ds,0}$ 3500mbar				<b>HD</b> small ball lock up to $W_{ds,0}$ 14000mbar			
		RS 254: DN 25 - 100 / RS 255: DN 50 - 80											
Spring data		lower response pressure		upper response pressure		lower response pressure		upper response pressure		lower response pressure		upper response pressure	
Feder Nr.	Colour [RAL]	$W_{ds,u}$ [mbar]	$\Delta p_{wu}$ [mbar]	$w_{dso}$ [mbar]	$\Delta p_{wo}$ [mbar]	$W_{ds,u}$ [mbar]	$\Delta p_{wu}$ [mbar]	$w_{dso}$ [mbar]	$\Delta p_{wo}$ [mbar]	$W_{ds,u}$ [mbar]	$\Delta p_{wu}$ [mbar]	$w_{dso}$ [mbar]	$\Delta p_{wo}$ [mbar]
FE 900	1028					0 - 10	50			0 - 38	500		
FE 901 VA	2002					6 - 30*	50			20 - 120*	500		
FE 902 VA	6010	0 - 12*	20			24 - 74	50			120 - 310*	500		
FE 903	5015	4 - 14	20			36 - 78	50			160 - 316	500		
FE 904 VA	9005	8 - 18	20			58 - 110	50			200 - 400	500		
FE 905 VA	9010	18 - 42	20			110 - 160	50			416 - 650	500		
FE 906	4002	48 - 70	20			162 - 250	50			560 - 940	500		
FD 910	1028			35 - 45	20			100 - 135	50			0 - 38	300
FD 911	2002			45 - 80	20			130 - 250	50			20 - 120	300
FD 912	6010			70 - 120	20			220 - 360	50			120 - 310	300
FD 913	5015			100 - 170	20			320 - 510	50			160 - 316	300
FD 914	9005			140 - 230	20			440 - 700	50			200 - 400	300
FD 915	9010			210 - 370	20			630 - 1130	50			416 - 650	300
FD 916	3020			330 - 570	20			1060 - 1750	50			560 - 940	300
FD 917	5010			460 - 830	20			1420 - 2520	50			4700 - 7300	300
FD 918	9006			650 - 1080	20			1850 - 3200	50			7300 - 12100	300
FD 919	4002			980 - 1500	20			2800 - 4600	50			11700 - 14000	300

## Setpoint spring table - SSV

		MD big ball lock up to $W_{ds,o}$ 300mbar				MD-R big ball lock up to $W_{ds,o}$ 3500mbar				HD big ball lock up to $W_{ds,o}$ 14000mbar			
		RS 254: DN 150 - 200 / RS 255: DN 100											
Spring data		lower response pressure		upper response pressure		lower response pressure		upper response pressure		lower response pressure		upper response pressure	
Feder Nr.	Colour [RAL]	$W_{ds,u}$ [mbar]	$\Delta p_{wu}$ [mbar]	$w_{dso}$ [mbar]	$\Delta p_{wo}$ [mbar]	$W_{ds,u}$ [mbar]	$\Delta p_{wu}$ [mbar]	$w_{dso}$ [mbar]	$\Delta p_{wo}$ [mbar]	$W_{ds,u}$ [mbar]	$\Delta p_{wu}$ [mbar]	$w_{dso}$ [mbar]	$\Delta p_{wo}$ [mbar]
FM 400	1028	10 - 40*	20			10 - 180*	50			0 - 250	500		
FM 402	6010	35 - 115	20			155 - 380	50			150 - 1000*	500		
FM 404	9005	60 - 245	20			200 - 950	50			650 - 2050	500		
FL 412	6010			40 - 180	20			145 - 670	50			380 - 1400	300
FL 413	5015			70 - 340	20			270 - 1230	50			800 - 2800	300
FL 415	9010							1200 - 4500	50			3200 - 5500	300
FL 417	4010											4500 - 14000	300

### Determining the upper response pressure

Outlet pressure $P_d$ (mbar)	Upper response pressure $W_{dso}$ ***
$\leq 200$	$P_d + 100$ mbar
$> 200 - \leq 800$	$P_d \times 1.5$
$> 800 - \leq 1600$	$P_d \times 1.3$
$> 1600$	$P_d + 500$ mbar

\*) if possible not greater than 450 mbar

\*\*) If the control device is set up for simultaneous monitoring of upper and lower response pressures, the difference between the setpoints for the upper and lower response pressures ( $p_{dso}$  and  $p_{dsu}$ ) should be at least 10% greater than the total of values given for  $\Delta p_{wo}$  and  $\Delta p_{wu}$ .

\*\*\*) The upper response pressure is rounded up to full tens, for example 251 mbar -> 260 mbar

# Dimensions, Connection and Weight

## Dimensional drawing

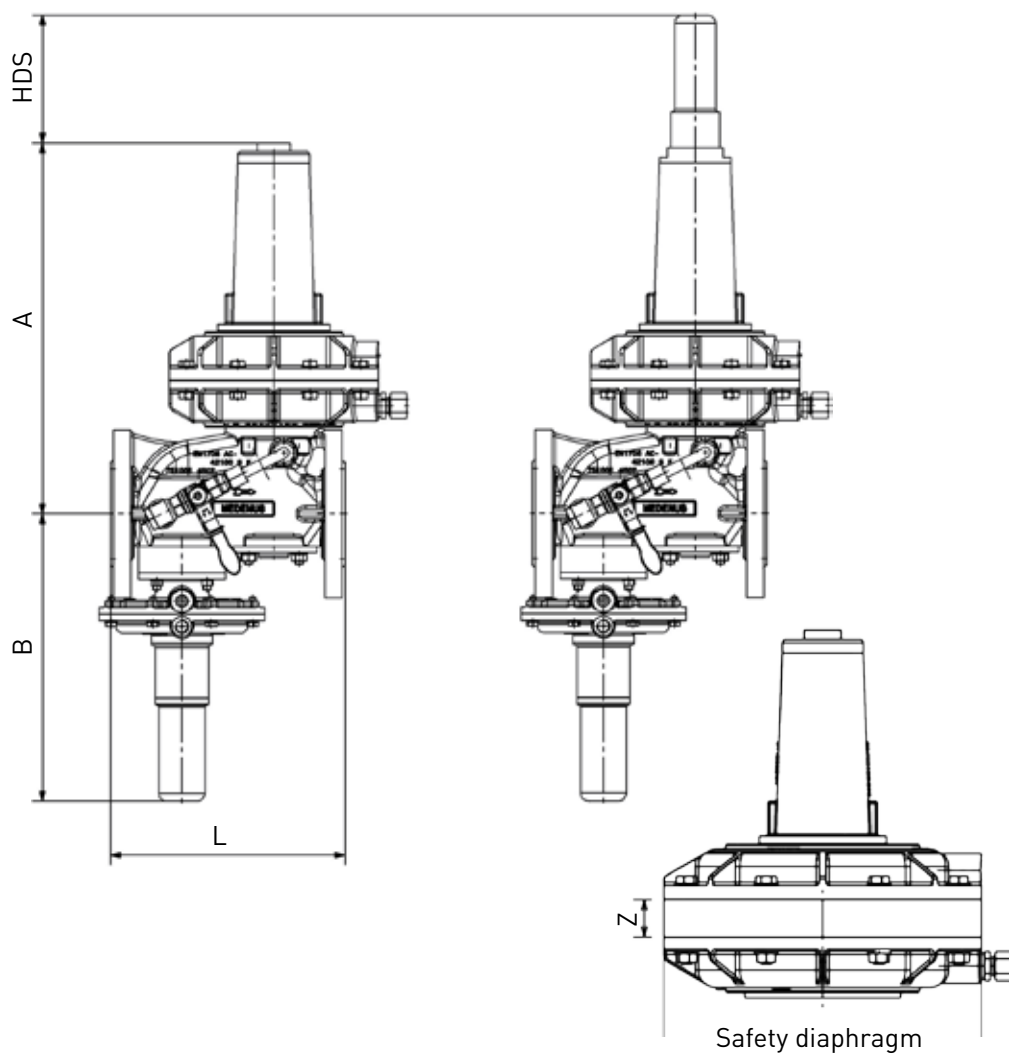

Dismounting dimensions for springs / HDS

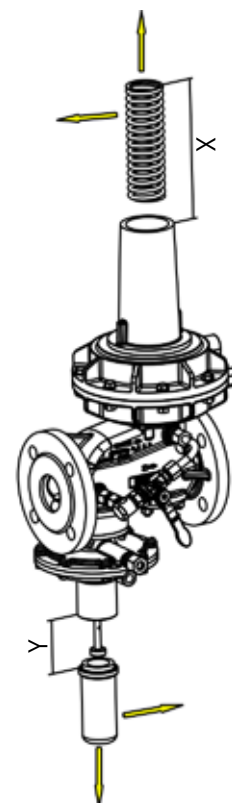

Reactivation of SSV

## Installation situation

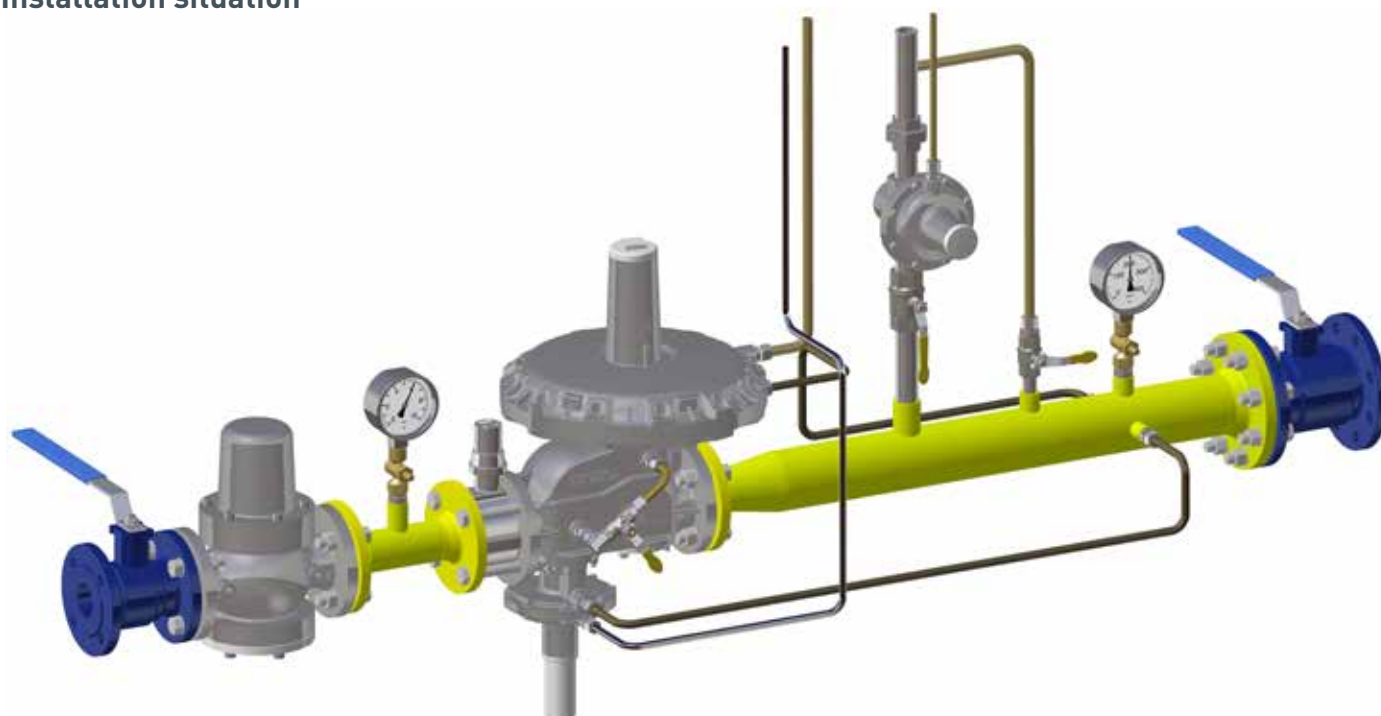



## Dimensions and weight

Nominal size		RS 250						RS 251			
		RE	DN 25	DN 50	DN 80	DN 100	DN 150	DN 200	DN 50	DN 80	DN 100
Dimensions	A [mm]	205	346	364	406	421	-	-	406	-	-
		275	-	-	406	421	730	799	406	658	730
		320	328	346	-	-	-	-	-	-	-
		385/390	-	-	406	421	716	785	406	644	716
		485	-	-	-	-	722	791	-	644	722
	HDS [mm]		125	125	125	125	205	205	125	205	205
	B [mm]		270	282	305	315	386	400	305	311	386
	L* [mm]		230	230	310	350	480	600	310	410	480
	X [mm]		260	260	260	260	410	410	260	410	410
	Y [mm]		100	100	100	100	150	150	100	150	150
	Safety diaphragm - SM Z [mm]		32.5	32.5	32.5	32.5	32.5	32.5	32.5	32.5	32.5
Weight [kg]		205	11.5	13	22	23	-	-	16	-	-
		275	-	-	24	25	52	82	19	37	52
		320	13.5	15	-	-	-	-	22	-	-
		385/390	-	-	28	29	58	88	-	42	58
		485	-	-	-	-	68	98	-	-	68
	HDS - Weight [kg]		0.6	0.6	0.6	0.6	1.6	1.6	0.6	1.6	1.6
Safety diaphragm - SM - Weight [kg]		205	2	2	2	2	-	-	2	-	-
		275	-	-	3	3	3.3	3.3	3	3.3	3.3
		320	3	3	-	-	-	-	-	-	-
		385/390	-	-	5	5	6	6	5	6	6
Connection	DIN EN 1092 - PN16										
	ASME B 16.5 - Class 150										

### Example:

RS250/050/320 with HDS and safety diaphragm

Weight (regulator + HDS + SM):  $15 \text{ kg} + 0.6 \text{ kg} + 3 \text{ kg} = 18.6 \text{ kg}$

Dimensions (A + HDS + SM):  $346 \text{ mm} + 125 \text{ mm} + 32.5 \text{ mm} = 503.5 \text{ mm}$

\* Alternatively, for the RS 250 for nominal sizes of DN 50, DN 80 and DN 100 the housings are also available on request in spheroidal cast iron (GJS)

## Dimensions, Connection and Weight

### RS 250: Connection of the measuring lines and breather lines

Nominal size	control unit		SSV control device / switching device	
	Measuring line	Breather line	Measuring line	Breather line
DN 025	Connection* for: Tube 12 x 1.5 (thread G 3/8)		Connection* for: tube 12 x 1.5 (thread G 1/4)	
DN 050				
DN 080				
DN 100			Connection* for: tube 12 x 1.5 (thread G 3/8)	
DN 150				
DN 200				

### RS 251: Connection of the measuring lines and breather lines

Nominal size	control unit		SSV control device / switching device	
	Measuring line	Breather line	Measuring line	Breather line
DN 050	Connection* for: Tube 12 x 1.5 (thread G 3/8)		Connection* for: tube 12 x 1.5 (thread G 1/4)	
DN 080				
DN 100			Connection* for: tube 12 x 1.5 (thread G 3/8)	

Note: Observe the following publications in relation to installation, start-up and maintenance:

DVGW - work sheets G 491 and G 600

Operating and Maintenance Instructions RS 250 /251

The gas pressure regulators RS 250 / 251 shall be installed in the pipeline preferably in horizontal position with vertical position of the control unit spring cap. For all nominal sizes, the direction of flow is indicated by an arrow on the housing.

## Selection

### Calculation of the required $K_G$ value

$$p_d / p_u > 0.5$$

$K_G$  value at  
a sub-critical pressure ratio

$$K_G = Q_n / \sqrt{p_d \cdot (p_u - p_d)}$$

$$p_d / p_u \leq 0.5$$

$K_G$  value at  
a super-critical pressure ratio

$$K_G = 2 \cdot Q_n / p_u$$

Note: all calculated pressures are absolute pressures.

### Device selection

The device is selected on the basis of its  $K_G$  value from the table of flow rate coefficients (page 8)

Note: For spring-loaded devices, a capacity reserve of 10-20% is recommended in order to comply with the accuracies given.

### Example:

$$p_{u \min} 5.0 \text{ bar} \quad / \quad p_{u \max} 8.0 \text{ bar}$$

$$p_{d \min} 0.3 \text{ bar} \quad / \quad p_{d \max} 0.5 \text{ bar}$$

$$Q_{n \min} 800 \text{ m}^3/\text{h} \quad / \quad Q_{n \max} 1500 \text{ m}^3/\text{h}$$

$$1.5 \text{ bar} / 6 \text{ bar} = 0.25 < 0.5$$

→ Supercritical pressure ratio  
 $K_G = 2 \cdot 1500 / 6 = 500 \text{ ((m}^3/\text{h))/bar}$

RS 250 DN 50 VS 32.5  
 $K_G$  value: 750 (m<sup>3</sup>/h)/bar

**Note:** To obtain a more accurate design configuration of our gas pressure regulators, you can use our configurator, on our homepage [medenus.de](http://medenus.de), under Service. ([medenus.de/de/service/konfigurator.html](http://medenus.de/de/service/konfigurator.html))

\*) Threaded pipe connections to DIN EN ISO 8434-1 (DIN 2353)

# Selection

## Device selection

For the small load  $Q_{\min}$  with SZ this yields 2.5:  $Q_{\min} = 0.025 \cdot K_G \cdot p_{u \max}$

Note: Small load  $Q_{\min}$  - When burner is started or at  $Q_{\min}$  a

$K_G$  utilization level of at least 1% should be reached.

Selection of the control unit from the diaphragm assembly setpoint spring table (page 10)

Selection of the closing pressure group from the closing pressure group table (page 9)

$$p_{f \max} = p_{ds} \cdot (1 + SG/100)$$

Selection of the SSVs from the SSV control device table (page 11)

Note: Recommended upper SSV response pressure  $p_{ds \ o} < 500 \text{ mbar} + p_{ds}$

Note: When selecting springs,  $AG_o$  and  $AG_u$  must be observed. The possible minimum and maximum response pressures are calculated as follows:

$$p_{dso \ min/max} = p_{ds \ o} \cdot (1 \pm AG_o / 100)$$

$$p_{dsu \ min/max} = p_{ds \ u} \cdot (1 \pm AG_u / 100)$$

$$p_{dso \ min} > p_{f \ max} \text{ and } p_{dsu \ max} \ll p_{ds} \cdot (1 - AC / 100)$$

Use of a leakage gas SRV:

Selection of leakage gas SRV - Settings from table (page 8)

Note: The opening pressure ( $p_{do}$ ) and closing pressure ( $p_{df}$ ) to be selected for the SRV must be greater than the maximum allowable closing pressure  $p_{f \ max}$  on the regulator. We recommend:  $p_{do} = p_{df} > 1.1 \cdot p_{f \ max}$

Note: When using an SRV,  $p_{dso \ min}$  must be  $> p_{ds} + p_{do} + p_{do \ tolerance}$  (page 8).

## Checking the gas velocities

$$w = 380 \cdot Q_n / (DN^2 \cdot p_{abs})$$

Note: The factor 380 refers to an operating gas temperature from approx. 15°C to 20°C. For other temperatures, the velocity must be corrected as follows:  $w_{corr} = w \cdot (t_{gas} + 273.15) / 290$

Recommended max. gas velocity at the inlet flange:

50 - 70 m/s Lower value for redirections upstream of the control valve, 20 m/s for upstream filters

Recommended max. gas velocity at the outlet flange:

100 - 200 m/s Lower value to reduce noise emissions

Recommended max. gas velocity on impulse tap: 15 - 25 m/s Lower value for outlet pressures below 100 mbar

$$Q_{\min} = 0.025 \cdot 750 \cdot 9 = 169 \text{ m}^3/\text{h}$$

RE320 with spring FA13 (300-600 mbar)

AC 5/SG 10 (for RE 320 valve  $\varnothing = 32.5$ )  
 $p_{f \ max} = 500 \cdot (1 + 10 / 100) = 550 \text{ mbar}$

MDR with FD 914 (440-770 mbar)  
AG<sub>o</sub> 10

set to  $p_{ds \ o} = 700 \text{ mbar}$   
and FE 904 (110-150 mbar) AG<sub>u</sub> 5  
set to  $p_{ds \ u} = 130 \text{ mbar}$

$$p_{dso \ max} = 700 \cdot (1 + 10 / 100) = 770 \text{ mbar}$$

$$p_{dso \ min} = 700 \cdot (1 - 10 / 100) = 630 \text{ mbar}$$

$$p_{dsu \ max} = 130 \cdot (1 + 5 / 100) = 136.5 \text{ mbar}$$

$$p_{dsu \ min} = 130 \cdot (1 - 5 / 100) = 123.5 \text{ mbar}$$

$$630 > 550 \text{ and } 136.5 \ll 475$$

FM 404 set to 60 mbar over 500 mbar

$$(p_{do} = p_{df} = 560 \text{ mbar})$$

FM 405 set to 90 mbar over 500 mbar

$$(p_{do} = p_{df} = 590 \text{ mbar})$$

Selected: FM 405 ( $p_{do} = p_{df} = 590 \text{ mbar}$ )

$$630 > 500 + 90 + 15$$

$$630 > 605$$

Inlet and outlet nominal size of the pipeline according to the selected device: 50 mm

Selected widening of outlet pipeline: 150 mm

$$w_u = 380 \cdot 1500 / (50^2 \cdot 6) = 38 \text{ m/s}$$

$$w_d = 380 \cdot 1500 / (50^2 \cdot 1.5) = 152 \text{ m/s}$$

$$w_{\text{impulse}} = 380 \cdot 1500 / (150^2 \cdot 1.5) = 17 \text{ m/s}$$

The device selected in the example of nominal size DN 50 can be operated under these conditions.

## Order data

### Example:

Gas pressure regulator: RS250/050/205/32,5/MD-R/HDS/links/SR/SM/RSD/BV/N/H/WAZ/So

Order selection	Designation	RS250	050	-	205	32.5	MD-R	-	HDS	links	SR	SBV	RSD	BV	N	H	WAZ	So	
<b>Type</b>																			
RS 250	RS250	RS 250																	
RS 251	RS251																		
<b>DN - Nominal size</b>	Table p.18		050																
<b>Flange model</b>																			
PN 16	-			-															
Class 150	C																		
<b>RE - Control unit</b>	Table p.19				205														
<b>D - Orifice (valve seat diameter)</b>	Table p.19					32.5													
<b>SSV</b>																			
with MD control device	MD																		
with MD-R control device	MD-R						MD-R												
<b>SSV functional class</b>																			
A	-							-											
B	B																		
<b>High-pressure screw spindle</b>																			
without	-																		
with high-pressure screw spindle	HDS								HDS										
<b>Direction of flow</b>																			
Right (from left to right)	-																		
Left (from right to left)	links									links									
<b>Noise reduction</b>																			
without	-																		
with noise reduction	SR										SR								
<b>Additional unit, control unit</b>																			
without	-																		
Safety diaphragm	SM											SM							
<b>Throttle valve</b>																			
without	-																		
with throttle valve	RSD												RSD						
<b>SSV valve accessories</b>																			
without	-																		
Breather valve	BV													BV					
<b>Electrical position indicator, SSV 'Closed'</b>																			
without	-																		
with ... , via proximity switch	N														N				
with ... , via Reed contact	R																		
<b>SSV release</b>																			
without	-																		
with manual release	H																	H	
with electromagnetic remote release, when power is supplied	SG																		
with electromagnetic remote release, in case of power failure	SA																		
<b>Acceptance test certificate to EN 10204/3.1</b>																			
without	-																		
with acceptance test certificate	WAZ																		WAZ
<b>Special model</b>	So*																		

### DN - Nominal size

Regulator type	025	050	080	100	150	200
RS250	X	X	X	X	X	X
RS251		X	X	X		

In each selection group, only one option can be selected in each case.

\*) for example coating with epoxy resin in RAL colours

## RE - Control unit

Regulator type	Nominal size	Description	Recommended use of the high-pressure screw spindle in the pressure range [mbar]	Outlet pressure ranges [mbar]
RS250	DN 25	with RE 320	200 - 800	18 - 200
		with RE 205	750 - 3.000	200 - 750
	DN 50	with RE 320	200 - 800	18 - 200
		with RE 205	750 - 3.000	200 - 750
	DN 80	with RE 390	130 - 450	18 - 130
		with RE 275	400 - 1.100	130 - 400
		with RE 205	750 - 3.000	400 - 750
	DN 100	with RE 390	130 - 450	18 - 130
		with RE 275	400 - 1.100	130 - 400
		with RE 205	750 - 3.000	400 - 750
	DN 150	with RE 485	150 - 450	18 - 150
		with RE 385	350 - 850	150 - 350
		with RE 275-2	850 - 3.000	350 - 850
	DN 200	with RE 485	150 - 450	18 - 150
		with RE 385	350 - 850	150 - 350
with RE 275-2		850 - 3.000	350 - 850	
RS251	DN 50	with RE 390	130 - 450	18 - 130
		with RE 275	400 - 1.100	130 - 400
		with RE 205	750 - 3.000	400 - 750
	DN 80	with RE 385	350 - 850	18 - 350
		with RE 275-2	850 - 3.000	350 - 850
	DN 100	with RE 485	150 - 450	18 - 150
		with RE 385	350 - 850	150 - 350
		with RE 275-2	850 - 3.000	350 - 850

## D - Orifice (valve seat diameter)

Regulator type	Nominal size	17.5	27.5	32.5	42.5	52.5	65	85	95	115
RS250	025	X	X							
	050	X	X	X						
	080		X	X	X					
	100		X	X	X	X				
	150				X	X	X	X	X	
	200								X	X
RS251	050		X	X	X	X				
	080				X	X	X	X		
	100				X	X	X	X	X	

## Contact

If you want to know more about our products and services, please contact your local representative or visit our website at [www.medenus.de/en](http://www.medenus.de/en).



**MEDENUS**  
Gas-Druckregeltechnik  
GmbH

Im Langen Feld 3



## THE MEDENUS PLUS

### 10 reasons for good business relations

1. Consultancy expertise and quality standards developed over decades
2. Broad and proven standard range of feedback controllers
3. Modern, fast and efficient production for series products and for individual orders
4. Customized design of pressure regulators and vacuum regulators and special designs
5. Guaranteed deadline compliance with a delivery time guarantee
6. Fast response time in all matters
7. Sufficiently large parts storage for production and spare parts
8. Customized theory & practice training courses
9. Modular design right across the entire product range to facilitate optimized handling of spare parts
10. Made in Germany









**In the download area of our homepage, different languages of this document are available. You can use the following QR codes and links to go directly to this document in your language.**

