

SPECIFICATIONS

Rated voltage	12 V DC	24 V DC
Pull current	31 A	15.2 A
Hold current	0.53 A	0.29 A
Duty service	Continuous (100%)	
Stroke	40 mm	
Force at starting	1.7 Kg	
Windings insulation class	H (180° C)	
Ambient temperature	-40° C ÷ 120° C	
Weight	0.76 Kg	

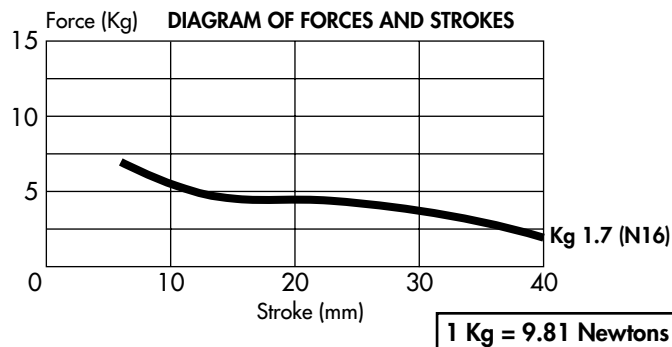

OPERATION

The solenoid has two windings:
 An intermittent-service pulling winding involved in the initial phase for approximately 150 ms, with the function of moving the plunger.
 A continuous-service holding winding, with the function of maintaining the plunger in position.
 For a proper operation of the solenoid, it is indispensable for the plunger to reach end of travel and to obtain the perfect adherence to the bottom.

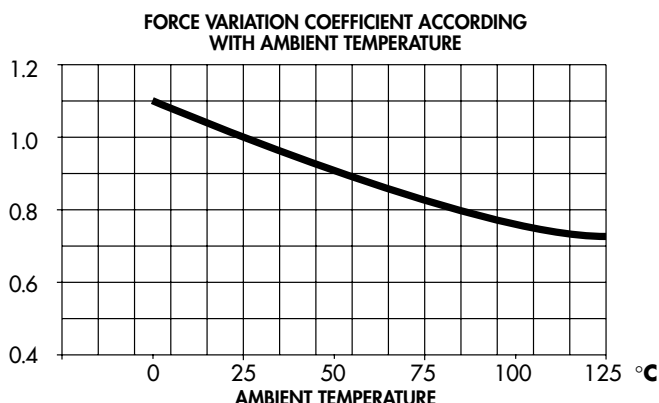

AVAILABLE OPTIONS

The desired model has to be defined choosing one option in every column, building in this way the solenoid code.

Versions	Voltages	Circuits	Brackets	Optional Springs	Electrical connections
E4 pull action	1 = 12 V DC	1 = Series 1	A	M1	Standard Faston
ES4 pull-push action	2 = 24 V DC	2 = Series 2	B	M2	F = Cables
		3 = Series 3	C	M3	V = Faston - screws

DUAL COIL SOLENOID FOR PULL ACTION OR PULL-PUSH ACTION

ELECTRIC CIRCUITS FOR DIESEL ENGINES

SERIES 1

WITH INTERNAL SWITCH

DIRECT ELECTRIC CIRCUIT

The solenoid connection is not conditioned by the polarity (+ and -) in the version with cables these are blue.

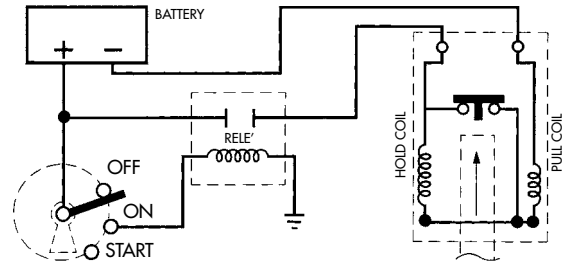

ELECTRICAL CONNECTIONS

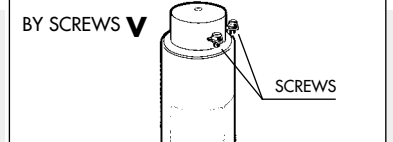
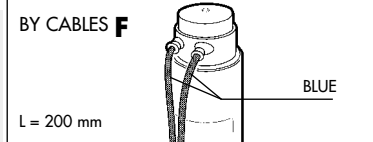
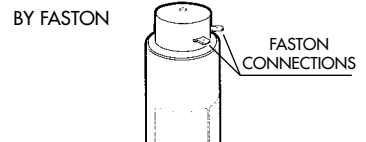

SERIES 2

WITH INTERNAL SWITCH

ELECTRIC CIRCUIT COMBINED WITH STARTER MOTOR

The solenoid connection feeding the pull coil P and the hold coil T is marked with the indication PULL (red cable) and HOLD (blue cable). The body is connected to ground. The pull coil P is fed in parallel with the starter motor: the red cable connected to the positive of the starter motor and the blue cable connected to the positive of the key switch. The auxiliary switch K ensures disconnection of the coil P and prevents the possible damaging return of parasitic currents.

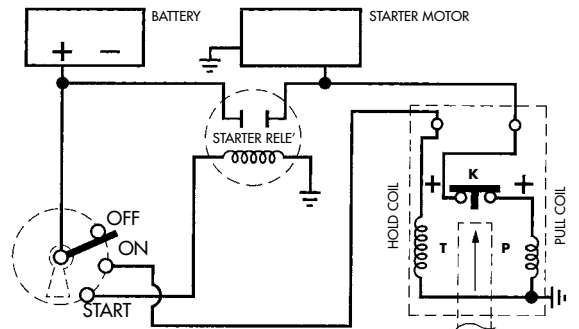

ELECTRICAL CONNECTIONS

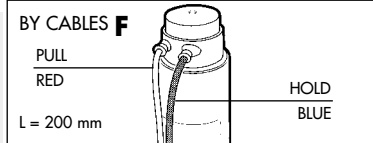

SERIES 3

WITHOUT INTERNAL SWITCH

The connection of the solenoid is the same as for the Series 2. The pull coil P and the hold coil T are respectively marked PULL and HOLD.

- Designed for coupling with starter motor.
- Designed for external switch (Code CEI IE04 - timed static electronic switch ideal for dusty or saline environments and in applications with repeated accelerations).

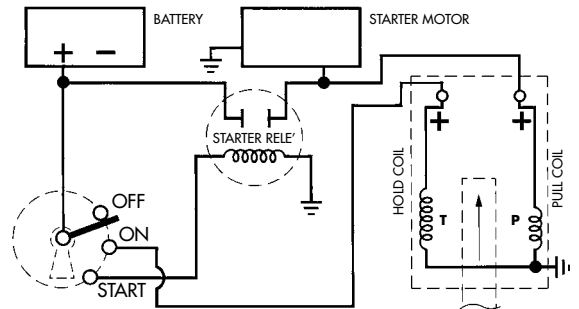

ELECTRICAL CONNECTIONS

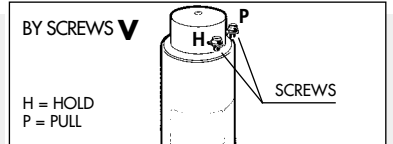
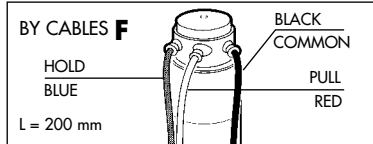
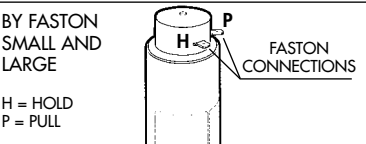

ACCESSORIES WITH M6 THREAD

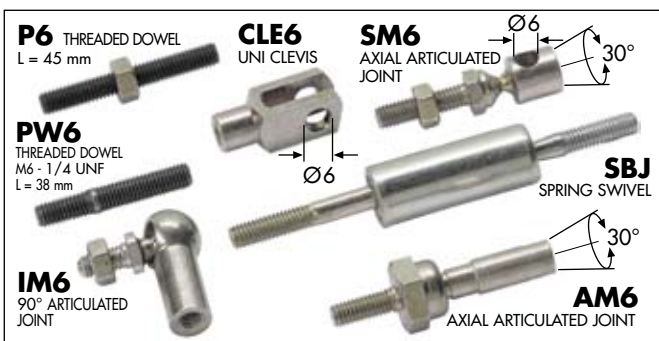

OPTIONAL SPRINGS

INTERNAL SPRING 4M1		INTERNAL SPRING 4M2		INTERNAL SPRING 4M3	
WIRE DIAMETER SPRING 1		WIRE DIAMETER SPRING 1.2		WIRE DIAMETER SPRING 1.3	
Kg 0.4 at 25 mm	Kg 1.5	Kg 0.9 at 25 mm	Kg 3.0	Kg 1.1 at 25 mm	Kg 4.0