

RIFTEK
Sensors & Instruments



BACK-TO-BACK DISTANCE MEASURING GAUGE

IMR-L Series

User's manual

Contents

1. Safety precautions and measurement conditions	3
2. Electromagnetic compatibility	3
3. Laser safety	3
4. General information	3
5. Basic data and performance characteristics	4
6. Complete set to be supplied	4
7. Example of item designation when ordering	5
8. Design.....	5
9. Operation principle.....	5
10. Working with the gauge	5
10.1. Gauge turn-on.....	5
10.2. Installation procedure.	5
10.3. Single measurement.....	5
10.4. Measurement with averaging.....	6
10.5. Gauge turn-out.....	6
11. Indication parameters setup.....	6
11.1. Image brightness set-up	6
11.2. Millimeters-Inches display set-up.....	7
11.3. Image rotation.....	7
12. Device calibration.....	7
12.1. Calibration conditions	7
12.2. Get into operational modes.....	8
12.3. Calibration of the sensor zero	8
13. Charging of built-in accumulator battery	8
14. Warranty policy	9
15. Distributors.....	9
16. Annex 1. RIFTEK measurement instruments for railway transport	12

1. Safety precautions and measurement conditions

- The metering accuracy depends greatly on the wheel surface quality. Therefore it is necessary to carry out the check and presorting of the wheel flaws before measuring the distance.
- Prior to place the gauge is a need to clean the wheels parts that contact with gauge and the place of laser beam hit.
- Do not allow hitting gage on the wheel when placing. **(See paragraph 10.2, Installation procedure).**
- It is necessary to inspect the gauge supports periodically and to cleanse them
- To save the battery power the display extinguishes if there were no buttons pressings for 60 seconds, at that only blinking dot is shown. Pressing any button just turns on the display and does not act in any other way in this case.

2. Electromagnetic compatibility

The back-to-back distance measuring gauge (IMR Series) has been developed for use in industry and meets the requirements of the following standards:

- EN 55022:2006 Information Technology Equipment. Radio disturbance characteristics. Limits and methods of measurement.
- EN 61000-6-2:2005 Electromagnetic compatibility (EMC). Generic standards. Immunity for industrial environments.
- EN 61326-1:2006 Electrical Equipment for Measurement, Control, and Laboratory Use. EMC Requirements. General requirements.

3. Laser safety

The device make use of an c.w. 660 nm wavelength semiconductor laser. Maximum output power is 1 mW. According to IEC 60825-1:2007 the device belong to the 2 laser safety class. The following warning label is placed on the laser body:

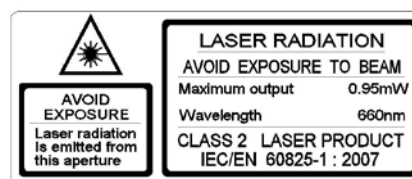

The following safety measures should be taken while operating the IMR:

- Do not target laser beam to humans;
- Do not disassemble the laser scanning module;
- Avoid staring into the laser beam.

4. General information

Gauge is designed for measuring back-to-back distance of railway, metro and tram wheels in the course of checkup, examination, repair and formation of wheel sets. Measurements are made directly on rolling stock without wheel set roll-out.

5. Basic data and performance characteristics

Name of parameter	Value
Measurement range, mm	1340...1610 or on request (nominal distance ± 15 mm)
Measurement error, mm	$\pm 0,2$
Indication discreteness	0.1mm, 0.01mm * or 0.01 inch
Display	build-in, LED
Operating temperature, 0C	-15...+50
Weigh, g	950
Dimensions	figure 1
Power supply	rechargeable batteries 4xAAA, 1.2V
Connection to PC	Bluetooth

6. Complete set to be supplied

Name	Quantity
Back-to-back distance measuring gauge, IMR-L series	1 piece
Charger	1 piece
Manual	1 piece
Case	1 piece
Calibration tools (option)	on request

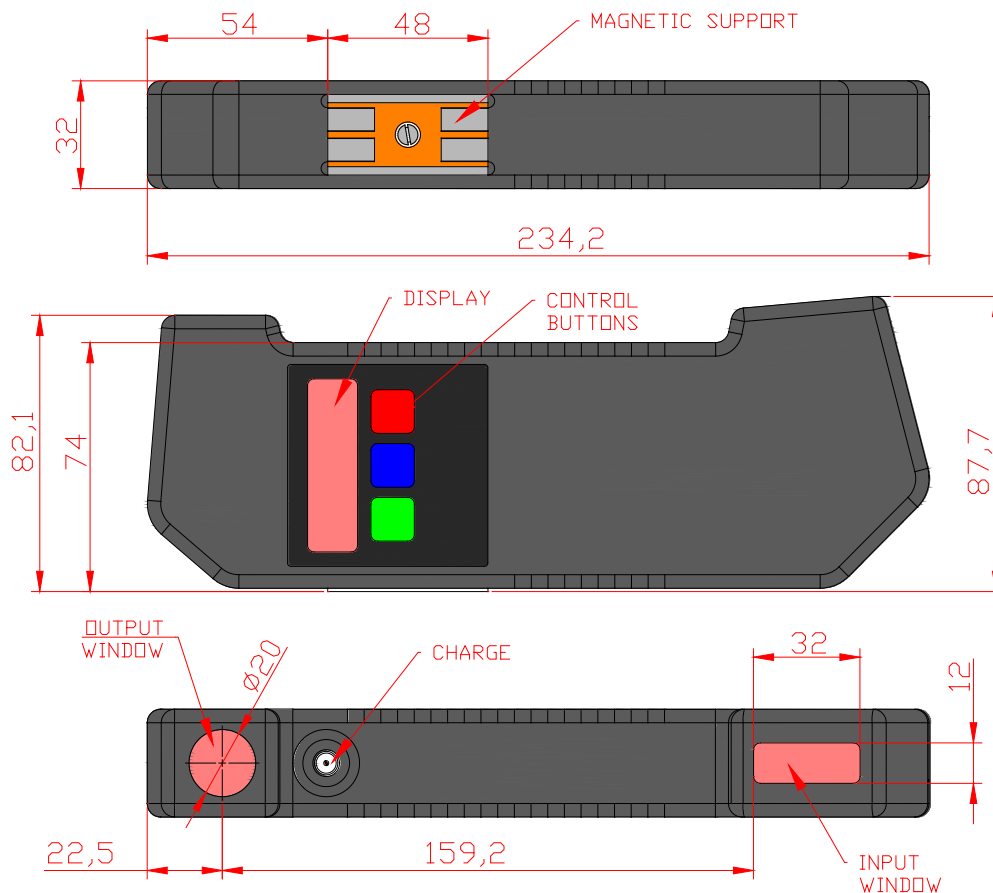

Figure 1

7. Example of item designation when ordering

IMR-L-D

Symbol	Name
D	Nominal back-to-back distance, mm

Example: IMR-L-1360 - nominal back-to-back distance – 1360 mm

8. Design

The gauge (fig.1) contains magnetic support to place the gauge onto the internal surface of the wheel.

There are a digital numeric display and control buttons on the front panel of the gauge. Output window for laser radiation, input window, “Charge” connector for charging device connection are placed on the side panel of the gauge.

9. Operation principle

The method of back-to-back distance measurement is based on the direct measurement the distance by laser triangulation sensor in-built onto the gauge.

10. Working with the gauge

10.1. Gauge turn-on

Press **Red** button to turn on the power. The display shows “**ErrP**” message if the accumulator battery voltage became lower than the control level. For such a case it is necessary to change batteries.

10.2. Installation procedure.

Attention! Avoid device shock. This can lead to calibration failure or optical elements breakdown.

To avoid device shock on the wheel refer to the following installation procedure:

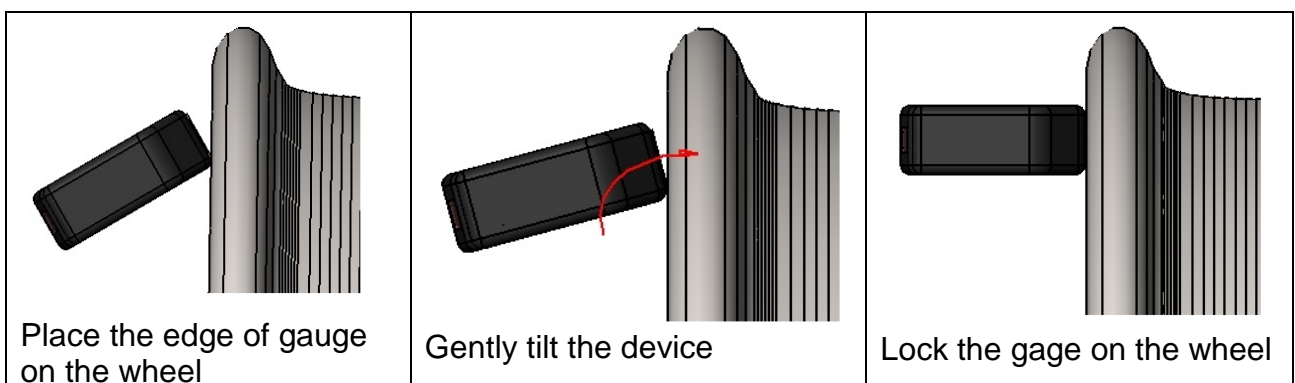

10.3. Single measurement

To perform measurement, it is necessary to:

- turn the power on (press **Red** button). The display shows “- - - -”;
- place the gauge on the inner surface of the wheel;
- make sure that the magnetic support is tight against the surface of the wheel;
- press **Green** button.
- in a 1 second the display will show the value back-to-back distance.

For viewing the result of measurement with indication discreteness of **0.01mm** (it is accessible only in a mode of direct indication) it is necessary to press **Blue** button, thus displayed result will be shifted to the left on one digit. Next pressing **Blue** button will lead to return of indication to a starting position:

10.4. Measurement with averaging

The program of the back-to-back distance calculation contains an averaging algorithm that allows eliminating the surface defects influence on the distance measuring result. All the results of metering, performed after the **Red** button pressing, are averaged. The measurement is meant to be **Green** button pressing.

To carry out measurements it is necessary to

- turn the power on (press **Red** button). The display shows “- - - -”;
- place the gauge;
- make sure the magnetic support is tight against the inner surface of the wheel;
- press **Green** button;
- display shows the value of pressing counter “n x”, where **x** – quantity of averaged values;
- in a 1 second display shows an average value of the back-to-back distance;
- move the gauge to a new position and repeat the measuring.
(The total quantity of measurements averaged in this way can run up to 9999.)
- Press **Red** button to reset averaging result at switching to another wheel.

For viewing the result of measurement with indication discreteness **0.01mm** (it is accessible only in a mode of direct indication) it is necessary to press **Blue** button, thus displayed result will be shifted to the left on one digit. Next pressing **Blue** button will lead to return of indication to a starting position.

10.5. Gauge turn-out

The gauge turn-out occurs automatically. The display extinguishes if there were no buttons pressings for 60 seconds, at that only blinking dot is shown. If there were no button pressings for 4 more minutes, the gauge is turned out completely. You can turn the gauge off by long pressing **Red** button (more then 3 sec.).

11. Indication parameters setup

11.1. Image brightness set-up

To change the display brightness it is necessary to:

- turn the power on (press **Red** button);
- press **Blue** button and keep it pressed for more than three seconds;
- display will show “Up”;
- press **Blue** button one more time, the image brightness set-up will be displayed “brt”;
- choose the necessary brightness value by **Green** button pressings;
- to save the changed parameters press **Red** button the display shows “SAUE” message, press the **Green** button to confirm saving and **Red** to cancel saving of the changed parameters;

At brightness choosing one should take into account that increased brightness enhances power consumption and decreases the period till battery recharge moment.

11.2. Millimeters-Inches display set-up

To change the mode it is necessary to:

- turn the power on (press **Red** button);
- press **Blue** button and keep it pressed for more than three seconds;
- display will show “**Up**”;
- press **Blue** button again until the either “**SI**” or “**Inch**” message appears on the display. “**SI**” – measuring results will be shown in mm, “**Inch**” – measuring results will be shown in inches;
- choose the necessary value by **Green** button pressings;
- to save the changed parameters press **Red** button the display shows “**SAUE**” message, press the **Green** button to confirm saving and **Red** to cancel saving of the changed parameters

NOTE: Discreteness of inch indication is two digits after point. The separation point is indicated at the top side of the screen in the reverse indication regime

11.3. Image rotation

Image rotation depending on gauge position is done automatically after **Measurement** button pressing.

12. Device calibration

This section contains the description of the modes for the check of device efficiency and calibration. As erroneous actions in this mode can lead to invalid measurement results, only specially trained personnel should perform such operations.

12.1. Calibration conditions

Attention! To achieve maximum accuracy, it is recommended to calibrate the device before operation.

To perform calibration the following means are necessary:

- Calibration tool RF260.90.000 fig.3;

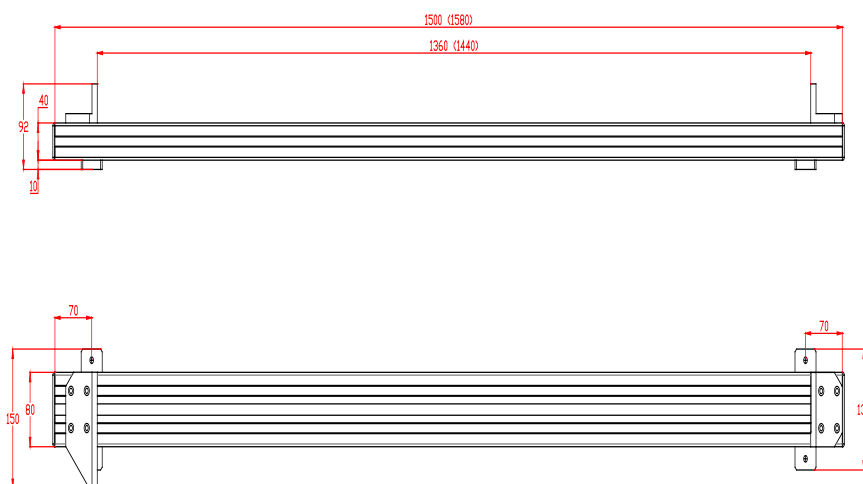

Figure 3

* - the length of calibration tool is checked with accuracy of 0,01 mm.

12.2. Get into operational modes

- To get into the operational modes it is necessary to turn-off the device (press **Red** button more than 3 seconds).
- Keeping **Green** button in pushed position turn-on the device (press **Red** button).
- Display shows “CLbr.0” message (the mode of calibration of the sensor's "0").
- To get into this mode press **Green** button (see. p.11.3).
- To get out the mode of calibration press **Red** button.

12.3. Calibration of the sensor zero

- Zero calibration mode being enabled, the display shows the length of calibration tool.
- If editing of the length value is not required, go to the next step. To edit the length value, press the **Blue** button, and the digit to be edited starts blinking. Changing over between the digits is made by pressing the **Blue** button while changing of values is made by pressing the **Green** button. When editing is finished, press the **Red** button and confirm or cancel saving of the parameter by pressing the **Green** button or **Red** button, respectively.
- Press the **Green** button, and the length value starts blinking, which means that the device must be placed onto calibration tool. The magnetic support of the gauge must be tightly fitted to the flat plates of calibration tool.
- Press the **Green** button, and the display shows current reading of the sensor in it own coordinate system.

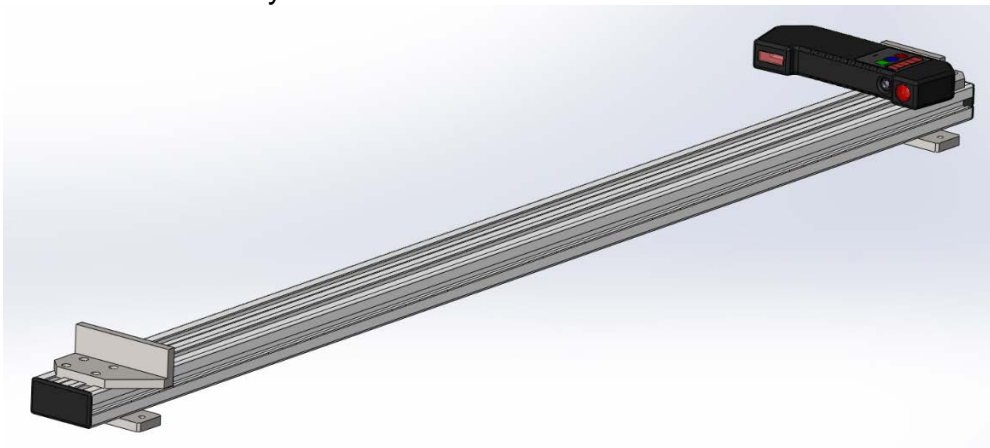

Figure 4

- If readings of the sensor are sufficiently stable, press the **Blue** button. Sensor zero position is calculated in the device coordinate system, and prompt appears to save calibration results. Press the **Green** or **Red** button to confirm or cancel saving of the results, respectively.

13. Charging of built-in accumulator battery

To charge accumulator battery it is necessary to connect charging device to the power grid 85-250V and to a battery compartment on the top panel of the gauge.

The period of charging is 15 hours.

14. Warranty policy

Warranty assurance for the Back-to-back measurement gauge IMR-L Series - 24 months from the date of putting in operation; warranty shelf-life - 12 months.

15. Distributors

<p style="text-align: center;">AUSTRIA</p> <p style="text-align: center;">MBM Industry & Rail Tech GmbH RAILWAY INSTRUMENTS ONLY Tullnerbachstraße 36, A-3002 Purkersdorf, Austria Tel: +43 2231 66000 Fax: +43 2231 66000 12 office@mbm-industrietechnik.at www.mbm-tech.at</p>	<p style="text-align: center;">AUSTRALIA</p> <p style="text-align: center;">Applied Measurement Australia Pty Ltd RAILWAY INSTRUMENTS ONLY Thornton Plaza, Unit 5, 27 Thornton Crescent, Mitcham VIC 3132, Australia Tel: +61 39874 5777 Fax: +61 39874 5888 sales@appliedmeasurement.com.au www.appliedmeasurement.com.au</p>	<p style="text-align: center;">BENELUX</p> <p style="text-align: center;">Altheris B.V. Vlietweg 17a, 2266KA Leidschendam, The Netherlands Tel: +31 70 3924421 Fax: +31 70 3644249 sales@altheris.nl www.altheris.com</p>
<p style="text-align: center;">BULGARIA, HUNGARY</p> <p style="text-align: center;">RMT Ltd. R Zahradni 224 739 21 Paskov, Czech Republic Tel: +420 558640211 Fax: +420 558640218 rmt@rmt.cz www.rmt.cz</p>	<p style="text-align: center;">BRAZIL</p> <p style="text-align: center;">CAPI Controle e Automação Ltda Rua Itororó, 121, CEP 13466-240 Americana-SP, Brazil Tel: +55 19 36047068 Tel: +55 19 34681791 capi@capicontrole.com.br www.capicontrole.com.br</p>	<p style="text-align: center;">CHILE</p> <p style="text-align: center;">Verne SpA Apoquindo 2818, oficina 31, Las Condes, Santiago, Chile Tel: +56 2 228858633 info@verne.cl isaavedra@verne.cl www.verne.cl</p>
<p style="text-align: center;">CHINA</p> <p style="text-align: center;">Zhenshangyou Technologies Co.,Ltd. Rm 2205-2210, Zhongyou Hotel 1110 Nanshan Road, Nanshan District 518054 Shenzhen, China Tel: +86 755-26528100/8011/8012 Fax: +86 755-26528210/26435640 info@51sensors.com www.51sensors.com</p>	<p style="text-align: center;">CHINA</p> <p style="text-align: center;">Shanghai micron-metrology com., Ltd. Room 602 unit 4, lane 399, Mudan road, Pudong New district Shanghai, China Tel: +86-21-68416510 sales@micron-metrology.cn www.micron-metrology.cn</p>	<p style="text-align: center;">CHINA</p> <p style="text-align: center;">JRKtech Co., Ltd. 1F, Building 9, 100 Xianlie Rd., Guangzhou, China Tel: +86 755 85267190/ +86 15989362481 Fax: + 86 755 85267190 sales@jrktech.com www.jrktech.com</p>
<p style="text-align: center;">CZECH REPUBLIC</p> <p style="text-align: center;">RMT Ltd. Zahradni 224 739 21 Paskov, Czech Republic Tel: +420 558640211 Fax: +420 558640218 rmt@rmt.cz www.rmt.cz</p>	<p style="text-align: center;">FINLAND</p> <p style="text-align: center;">TERÄSPYÖRÄ-STEELWHEEL OY RAILWAY INSTRUMENTS ONLY Juvan teollisuuskatu 28 FI-02920 ESPOO, Finland Tel: +358 400 422 900 Fax: +358 9 2511 5510 steelwheel@steelwheel.fi www.teraspyora.fi</p>	<p style="text-align: center;">FRANCE</p> <p style="text-align: center;">DB Innovation (ALTHEIRIS France) 26, avenue de la Mediterranee 34110 Frontignan France Tel: +33-467786166 Fax: +33-467740134 dbi@altheris.fr www.altheris.fr</p>

<p>GERMANY</p> <p>Disynet GmbH Breyeller Str. 2 41379, Brueggen Tel: +49 2157 8799-0 Fax: +49 2157 8799-22 disynet@sensoren.de www.sensoren.de</p>	<p>GERMANY</p> <p>BIP-Industrietechnik GmbH RAILWAY INSTRUMENTS ONLY Am Elisabethhof 22, D-14772 Brandenburg D-41379 Brueggen, Germany Tel: +49 (0) 33 81 75 90 0 Fax: +49 (0) 33 81 75 90 11 info@bip-industrie.de www.bip-industrietechnik.de</p>	<p>GERMANY</p> <p>Finger GmbH & Co. KG OPTICAL MICROMETERS ONLY Sapelloh 172, 31606 Warsmen, Germany Tel: +49 5767 96020 Fax: +49 5767 93004 finger@finger-kg.de www.finger-kg.de</p>
<p>GERMANY</p> <p>Hylewicz CNC-Technik SHTRIKH-2 ONLY Siemensstrasse 13-15, 47608 Geldern, Germany Tel: +49 2831 91021-20 Fax: +49 2831 91021-99 info@cnc-step.de www.cnc-step.de</p>	<p>INDIA</p> <p>Pragathi Solutions #698, 5th Main, 8th Cross, HAL 3rd Stage, New Tippasandra Road, Bangalore, 560075, India Tel: +91 80 32973388 Tel/fax: +91 80 25293985 Mobile: +91 9448030426/ +919448492380 sales@pragathisolutions.in arghya@pragathisolutions.in www.pragathisolutions.in</p>	<p>INDIA</p> <p>BPI (India) RAILWAY INSTRUMENTS ONLY 63,Civil Lines, Near Bhagirathi Colony, Roorkee, 247667, India Tel: +91 1332274743 Tel: +91 9319686784 sales@bpi-india.in www.bpi-india.in</p>
<p>INDONESIA</p> <p>PT. DHAYA BASWARA SANI-YASA Botanic Junction Blok H-9 NO. 7 Mega Kebon Jeruk, Joglo Jakarta 11640, Indonesia Tel: +62 21 29325859 management@ptdbs.co.id</p>	<p>IRAN</p> <p>Novin Industrial Development Grp. Tel: +98 21 44022093-6 Fax: +98 21 43858794 Mobile: +98 9123207518 info@novinid.com www.novinid.com</p>	<p>ISRAEL</p> <p>Nisso Dekalo Import Export LTD 1 David Hamelech Street Herzlia 46661 Israel Tel: +972-99577888 Fax: +972-99568860 eli@fly-supply.net www.fly-supply.net www.aircraft-partsupply.com</p>
<p>ITALY</p> <p>FAE s.r.l. Via Tertulliano, 41 20137 Milano, Italy Tel: +39-02-55187133 Fax: +39-02-55187399 fae@fae.it www.fae.it</p>	<p>LATVIA, ESTONIA</p> <p>SIA "SOLARTEX" RAILWAY INSTRUMENTS ONLY Duntes 15a, 5th floor, office B7 Riga, Latvia Tel.: +371 67 130 787 solartex@inbox.lv</p>	<p>MALAYSIA</p> <p>OptoCom InstruVentures H-49-2, Jalan 5, Cosmoplex Industrial Park, Bandar Baru Salak Tinggi, Sepang, Malaysia Tel: +603 8706 6806 Fax: +603 8706 6809 optocom@tm.net.my www.optocom.com.my</p>
<p>NORWAY</p> <p>Salitec AS PB 468, N-1327 Lysaker Tel.: +47 23 891015 Fax: +47 92101005 mail@salitec.no www.salitec.no</p>	<p>PERU</p> <p>Verne Perú S.A.C Las Codornices 104, Surquillo, Lima, Peru Tel/fax: +51 992436734 info@verne.cl info@verne.com.pe www.verne.cl</p>	<p>POLAND</p> <p>MTL ASCO Sp. z o.o. RAILWAY INSTRUMENTS ONLY ul. Wielowiejska 53 44-120 PYSKOWICE, Poland Tel: + 48 32 230 45 70 Fax: + 48 32 332 70 14 biuro@ascorail.pl www.ascorail.pl</p>

<p style="text-align: center;">PORTUGAL</p> <p style="text-align: center;">UltraSens Qt. da Portela, Lt. 22.1, Ap. 152 3030 - 502 Coimbra, Portugal Phone +351 239 796 277 Fax: +351 239 918 267 info@ultrasens.com www.ultrasens.com</p>	<p style="text-align: center;">RUSSIA</p> <p style="text-align: center;">Sensorika-M LLC Dmitrovskoye shosse 64-4 127474, Moscow, Russia Tel: +7 499 487 0363 Fax: +7 499 487 7460 info@sensorika.com www.sensorika.com</p>	<p style="text-align: center;">RUSSIA</p> <p style="text-align: center;">Diesel-test-Komplekt LLC 620030, Karjernaya St, 16 Ekaterinburg, Russia Tel/fax: +7 343 2227565 Tel/fax: +7 343 2227370 mail@d-test.ru www.d-test.ru</p>
<p style="text-align: center;">SERBIA, SLOVAKIA</p> <p style="text-align: center;">RMT Ltd. Zahradni 224 739 21 Paskov, Czech Republic Tel: +420 558640211 Fax: +420 558640218 rmt@rmt.cz www.rmt.cz</p>	<p style="text-align: center;">SOUTH AFRICA</p> <p style="text-align: center;">Ratcom Enterprise Pty Ltd CSIR BUILDING 35, Office 78 Meiring Naude Road, Brummeria Pretoria, 0084 South Africa Tel: + 27 12 841 2032 Fax: + 27 86 225 0650 info@ratcom.co.za www.ratcom.co.za</p>	<p style="text-align: center;">SOUTH KOREA</p> <p style="text-align: center;">PROSEN. CO., LTD M-1001, Songdo techno park IT center, 32, Songdogwahak-ro, Yeonsu-gu, Incheon, 21984, Republic of Korea Tel: +82-32-811-3457 Fax: +82-32-232-7458 trade@prosen.co.kr www.prosen.co.kr</p>
<p style="text-align: center;">SPAIN</p> <p style="text-align: center;">Iberfluid Instruments S.A. C/ Botanica, 122 08908 L'Hospitalet de Llobregat, Barcelona Tel: +34 93 447 10 65 Fax: +34 93 334 05 24 myct@iberfluid.com www.iberfluid.com</p>	<p style="text-align: center;">SWITZERLAND</p> <p style="text-align: center;">ID&T GmbH Gewerbestrasse 12/a 8132 Egg (Zurich), Switzerland Tel: + 41 44 994 92 32 Fax: + 41 44 994 92 34 info@idtlaser.com www.idtlaser.com</p>	<p style="text-align: center;">SWEDEN, DENMARK</p> <p style="text-align: center;">BLConsult Ryssbält 294, 95 291 KALIX, Sweden Mobile: +46 70 663 19 25 info@blconsult.se www.blconsult.se</p>
<p style="text-align: center;">THAILAND</p> <p style="text-align: center;">Advantech Solution Co.,Ltd. 20/170 Motorway Rd., Kwang Pravet, Khet Pravet, Bangkok, Thailand 10250 Tel: +662-1848705 Fax: +662-1848708 sales@advantechsolution.com www.advantechsolution.com</p>	<p style="text-align: center;">TURKEY</p> <p style="text-align: center;">TEKMA Mühendislik A.Ş. Cevizli Mh. M. Kemal Cd., Hukukçular Towers, A-Blok, No: 66-A/39 Kartal – Istanbul Tel: +90 216 970 1318 Tel: +90 850 840 2334 info@tekma.eu www.tekma.eu</p>	<p style="text-align: center;">UKRAINE</p> <p style="text-align: center;">KODA Frunze st 22 61002, Harkov, Ukraine Tel/fax: +38 057 714 26 54 mail@koda.com.ua www.koda.com.ua</p>
<p style="text-align: center;">UNITED KINGDOM, IRELAND</p> <p style="text-align: center;">Ixthus Instrumentation Ltd The Stables, Williams' Barns Tiffield road, Towcester, Northants Tel: +44 1327 353437 Fax: +44 1327 353564 info@ixthus.co.uk www.ixthus.co.uk</p>	<p style="text-align: center;">USA, CANADA, MEXICO</p> <p style="text-align: center;">International Electronic Machines Corporation RAILWAY INSTRUMENTS ONLY 850 River Street, Troy, New York, USA Tel: +1 518 268-1636 Fax: +1 518 268-1639 marketing@iem.net www.iem.net</p>	<p style="text-align: center;">USA, CANADA, MEXICO</p> <p style="text-align: center;">Acuity Products of Schmitt Industries, Inc. 2765 NW Nicolai Street Portland, OR, 97210, USA Tel: +1 503 227 7908 Fax: +1 503 223 1258 sales@acuitylaser.com www.acuitylaser.com</p>

16. Annex 1. RIFTEK measurement instruments for railway transport

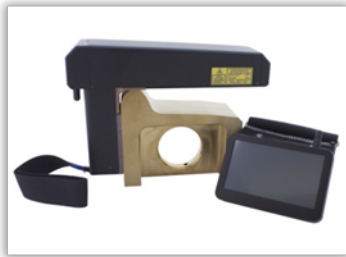

Laser wheel profilometer. IKP Series

A laser profilometer is designed for the measuring of:

- wheel flange height;
- wheel flange thickness;
- wheel flange slope;
- full profile scanning and analyze of wheel rolling surface;
- maintaining of electronic wear data base;
- control of tolerances and sorting in the course of checkup, examination, repair and formation of railway wheel sets;

Measurements are made directly on rolling stock without wheel set roll-out.



Portable laser rail profilometer. PRP Series

The main functions of PRP are:

- obtaining the information on the cross-section profile of the working railhead surface;
- full profile scanning and analyze of the railhead acting face;
- visualization of the combined graphical images of actual and new cross-section railhead profiles on the display of system unit.



Wheel diameter measuring gauge. IDK Series

Electronic gauge is designed for measuring wheel rolling circle diameter of railway, metro and tram wheel sets.

Measurements are made directly on rolling stock without wheel set roll-out.



Back-to-back distance measuring gauge. IMR Series

Gauge is designed for contactless measuring of back-to-back distance of railway, metro and tram wheels in the course of checkup, examination, repair and formation of wheel sets. Measurements are made directly on rolling stock without wheel set roll-out.



Back-to-back distance measuring gauge. IMR-L Series

Gauge is designed for contactless measuring of back-to-back distance of railway, metro and tram wheels in the course of checkup, examination, repair and formation of wheel sets. Measurements are made directly on rolling stock without wheel set roll-out.



Disc brakes profile gauge. IKD Series

Laser disc brakes profilometer IKD Series is designed for disc brakes profile measuring.

The main functions of IKD are:

- obtaining the information on the profile parameters of the working disc brakes surface;
- full profile scanning and analyze of the disc brakes acting face;
- visualization of the combined graphical images of actual and new disc brakes profiles on the display of system unit.



Automatic real-time system for measurement of wheel-sets geometrical parameters

The system is designed for contactless automatic measurement of geometrical parameters of railway wheels and uses a combination of 2D laser scanners, mounted wayside in the track area.

The system can be easily installed at any type of rail infrastructure.