

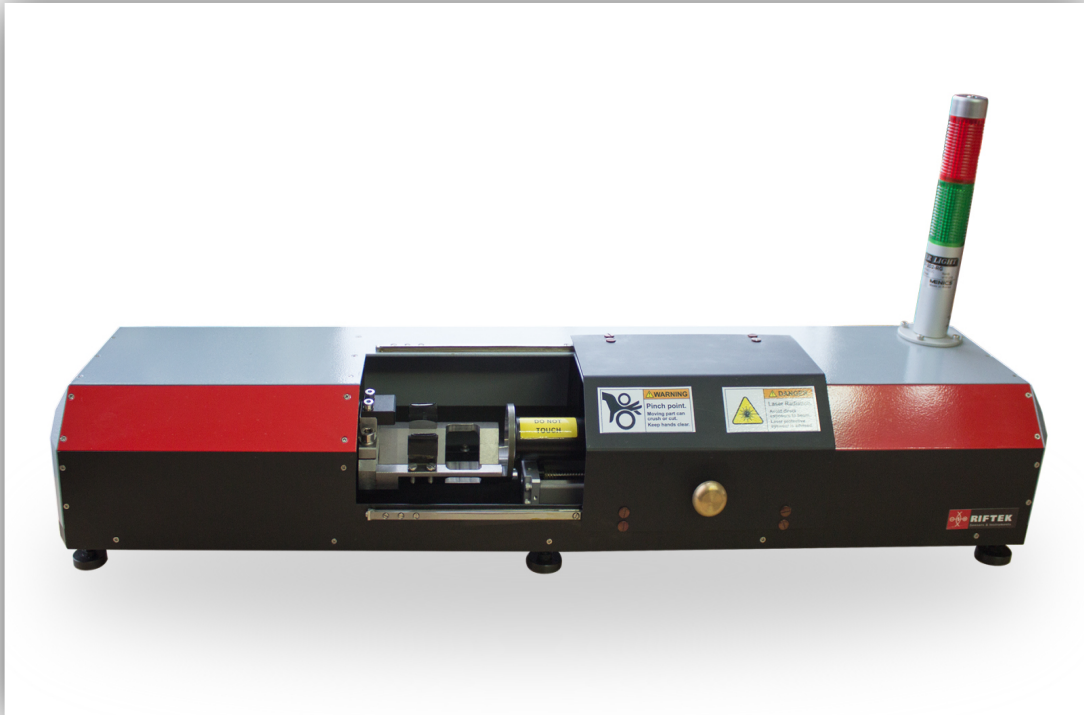

RIFTEK
Sensors & Instruments



PIPE INNER DIAMETER MEASUREMENT MACHINE

RF096-32/42-80 Series

User's Manual

Contents

1.	Safety precautions.....	3
2.	CE compliance.....	3
3.	Laser safety.....	3
4.	General information.....	3
5.	Basic technical data.....	4
6.	Example of item designation when ordering.....	4
7.	Structure and operational principle.....	4
8.	Connection.....	5
9.	Network setting.....	5
10.	Service program.....	6
10.1.	System requirements.....	6
10.2.	Installation.....	6
10.3.	License activation.....	7
10.4.	Pipe Check.....	7
10.4.1.	Main window.....	7
10.4.2.	Calibration.....	8
10.4.3.	Measurement procedure.....	9
10.4.4.	Templates settings.....	10
10.4.5.	Log.....	13
11.	Troubleshooting.....	13
12.	Technical support.....	13
13.	Warranty policy.....	13
14.	Distributors.....	14

1. Safety precautions

- Use supply voltage and interfaces indicated in the machine specifications.
- In connection/disconnection of cables, the machine power must be switched off.
- Do not use the machine in locations close to powerful light sources.
- To obtain stable results, wait about 20 minutes after the machine activation to achieve uniform warm-up of the laser sensor.

2. CE compliance

The machine has been developed for use in industry and meets the requirements of the following Directives:

- EU directive 2014/30/EU. Electromagnetic compatibility (EMC).
- EU directive 2011/65/EU, “RoHS” category 9.

3. Laser safety

The laser sensor of the system makes use of a c.w. 660 nm wavelength semiconductor laser. Maximum output power is 1 mW. The sensor belongs to the 2 laser safety class. The following warning label is placed on the housing:

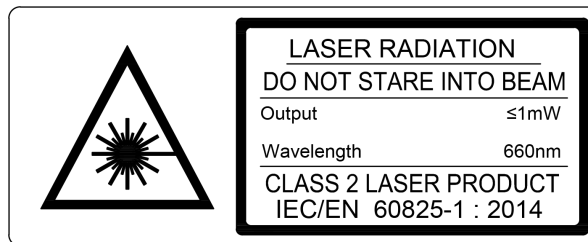

The following safety measures should be taken while operating the sensor:

- Do not target laser beam to humans.
- Do not disassemble the sensor.
- Avoid staring into the laser beam.

4. General information

The machine is designed for contactless scanning and geometrical parameters measurement of inner diameter of pipes, bushes, holes, tubes, and so on.

Field of application: large-scale production.

5. Basic technical data

Parameter		Value
Diameter measurement range, mm		32...42
Diameter measurement accuracy, μm		± 5
Depth of measured hole, mm		≤ 80
Linear translation accuracy, μm		± 20
Quantity of measured sections		not limited, programmable
Light source		red semiconductor laser, 660 nm wavelength
Laser sensor output power, mW		< 1
Laser safety class		2 (IEC60825-1)
Output interface		Ethernet
Power supply		220 V AC
Environmental resistance	Vibration	20 g / 10...1000 Hz, 6 hours for each of XYZ axes
	Shock	30 g / 6 ms
	Permissible ambient light, lx	30000
	Relative humidity, %	5-95 (no condensation)
	Operating ambient temperature, $^{\circ}\text{C}$	0...+45
	Storage temperature, $^{\circ}\text{C}$	-20...+70
Housing material		aluminum

Note: machine parameters can be changed for a specific task.

6. Example of item designation when ordering

RF096-Dmin/Dmax-L

Symbol	Description
Dmin/Dmax	ID measurement range, mm.
L	Hole depth, mm.

Example: RF096-32/42-80 – Pipe Inner Diameter Measurement Machine RF096, diameter measurement range - 32...42 mm, depth of measurement - 80 mm.

7. Structure and operational principle

Operation of the machine is based on the principle of laser scanning of rotating pipe inner surface by triangulation laser point sensor.

Structure of the machine is shown in Figure 1.

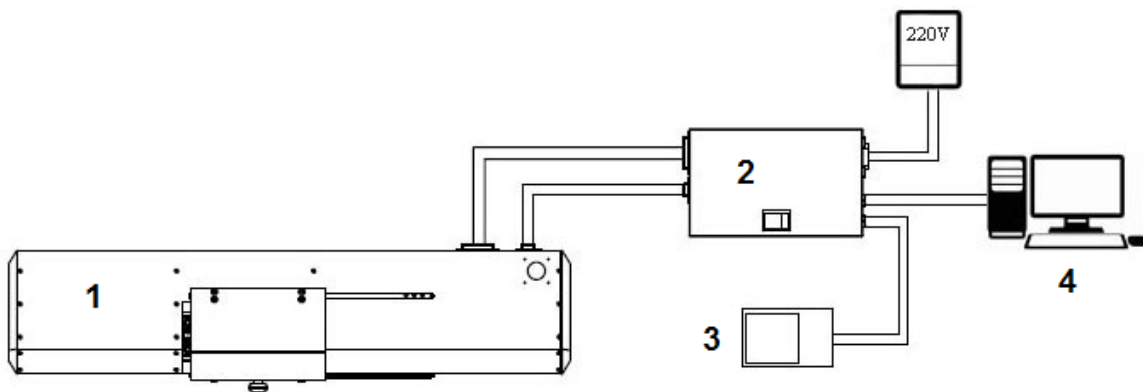

Figure 1.

where:

- 1 - measurement module,
- 2 - controller with the power supply,
- 3 - foot switch,
- 4 - personal computer with a service program.

The measurement module structural design is illustrated in Figure 2.

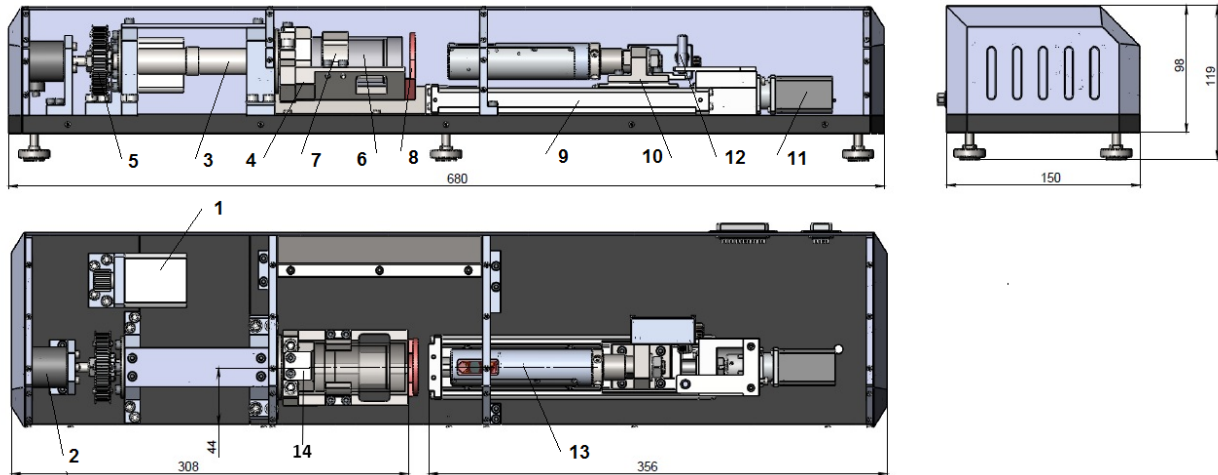

Figure 2.

The measurement module includes a base, on which the rotation mechanism and the linear movement mechanism are installed. The housing of the measurement module is equipped with a signal tower (not shown).

The rotation mechanism includes a stepper motor (1), encoder (2), shaft (3) with a V-block (4). The transmission of rotation from the stepper motor (1) to the shaft (3) is carried out by means of a belt drive (5). The V-block (4) is intended to install the controlled pipe (6) and has two plate springs (7), which intended for holding the pipe on the V-block, and a calibration ring (8). The pipe must be pressed to the thrust plate (14).

The linear movement mechanism includes guide rails (9), carriage (10), stepper motor (11), end switch (12). The carriage (10) is moved by a ball screw, and carries a laser triangulation sensor (13).

The machine operates as follows:

The operator installs the controlled pipe (6) into the V-block (4). On the operator's command, a laser sensor (13) moves into the control zone of the calibration ring (8), and the V-block (4) is driven to rotate. During rotation, a laser sensor measures the distance to the surface of the ring in synchronization with the angle of rotation determined by the encoder (2). Upon completion of one turn of the V-block, a laser sensor moves to the next control position, and the measurement process is repeated. The number of diameter control sections along the pipe is defined by the software.

Radial coordinates of the calibration ring surface and controlled pipe are transmitted to the PC for calculating the required geometric parameters.

8. Connection

Make connections in accordance to block diagram shown in [Figure 1](#). Connect measurement module to controller by means of two cables (Ethernet and Power supply). Connect foot switch to controller. Connect controller to PC and to 220 V AC.

9. Network setting

The machine is shipped with the following default network configuration: IP address of the machine – 192.168.1.3.

Configure your PC's network card in the following address space: 192.168.1.X. Connect the machine directly to your PC or through the network switch.

10. Service program

In order to work with the machine, you need to [install](#) the RFClearView software, and to [activate](#) the license.

10.1. System requirements

The main requirements for using RFClearView:

- Operating system Windows 7 and later.
- Video card and video card drivers, which support OpenGL 2.1 and later.

10.2. Installation

Before starting the installation, read the following information.

The RFClearView software comes in two versions – 64 and 32 bits. To determine a correct version, refer to the System Properties window or to your system administrator.

Setup files for each version exist in two implementations:

- Standalone setup file (**RFclearViewSetup_offline.exe**) contains a version of RFClearView on the date of the setup file creation.
- Setup file via the internet (**RFclearViewSetup_online.exe**) will download and install the latest version of RFClearView.

Download links of the latest versions:

Windows **x64**:

https://riftek.com/media/rit/repos/installers/RFclearViewSetup_online_x64.exe

https://riftek.com/media/rit/repos/installers/RFclearViewSetup_offline_x64.exe

Windows **x32**:

https://riftek.com/media/rit/repos/installers/RFclearViewSetup_online.exe

https://riftek.com/media/rit/repos/installers/RFclearViewSetup_offline.exe

The installation is performed by the specially created installer.

To start the installation, you need to run the setup file **RFclearViewSetup_online.exe/RFclearViewSetup_offline.exe**.

When you run the installation, Welcome Window appears:

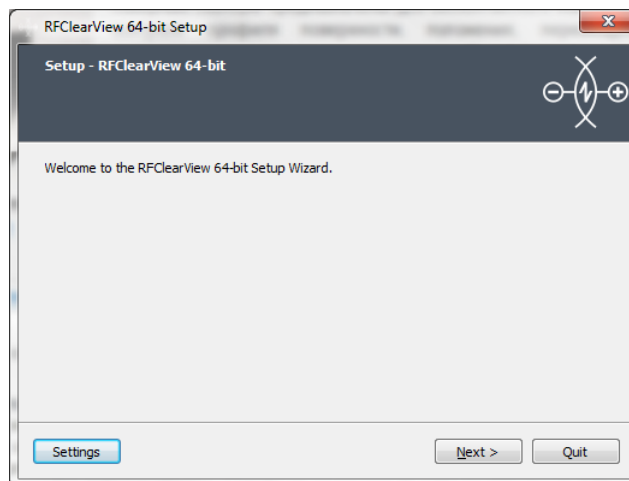

To continue with the installation, click **Next**.

Follow the guidelines in dialog boxes of the installer.

10.3. License activation

In order to activate the license, click  in the upper right corner of the program window, go to the **About** tab, and click the link with the license type name. The activation window appears:

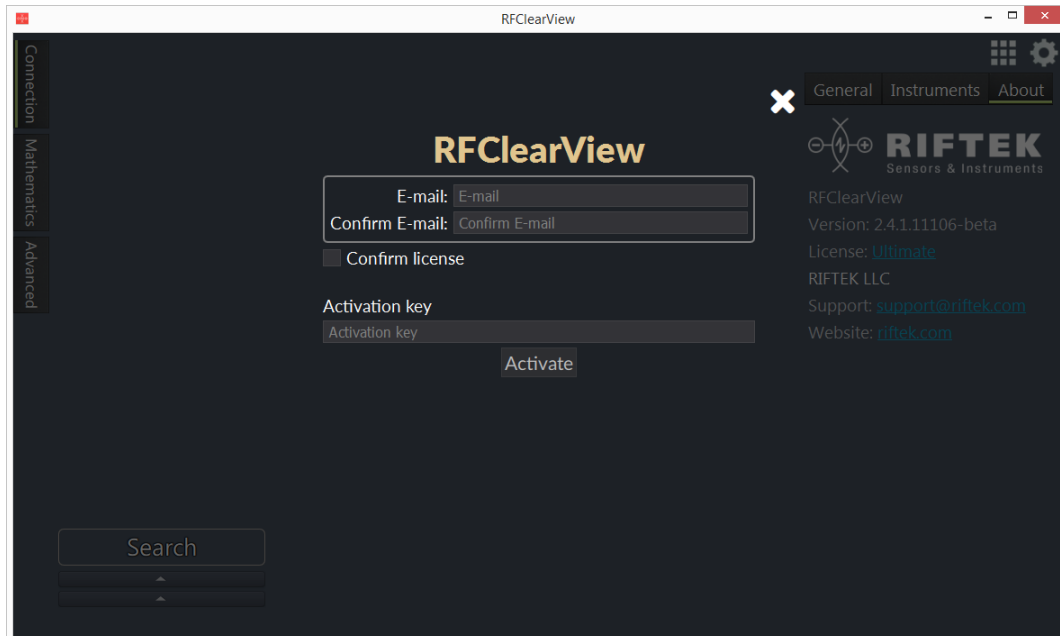



Next, enter your email and confirm it, select **Confirm license**, enter the activation key, and click **Activate**.

10.4. Pipe Check

10.4.1. Main window

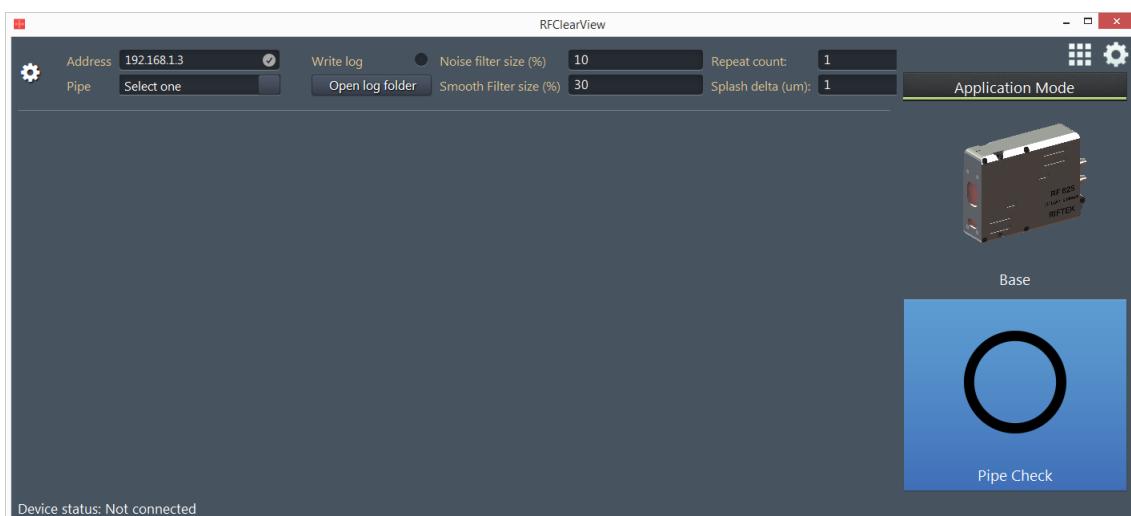
Run RFClearView, click on the sign  located on the upper right corner of the program window, and select **Pipe Check**:



The selected program will be highlighted in blue. To hide the **Application Mode** panel and to expand **Pipe Check** on the entire window, click  again.

The main window:

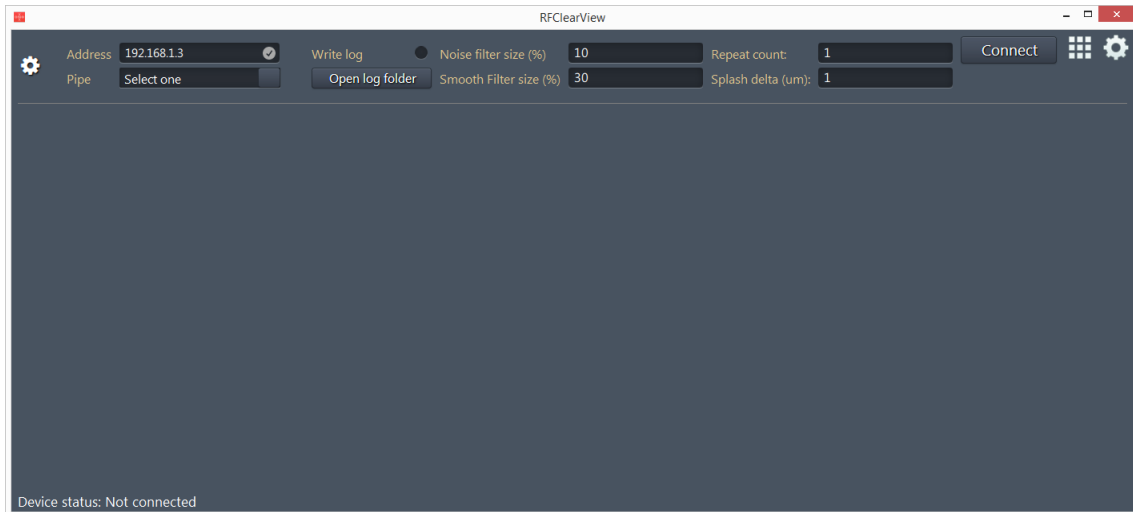

The main window description:

Address	TCP/IP address of the machine. Note: the machine and your PC must be in the one subnet.	
Pipe	Pipe type selection.	
Write log	Write log option.	
Open log folder	Open the folder with log files.	
Noise filter size (%)	10% by default.	Do not change these parameters.
Smooth filter size (%)	30% by default.	
Repeat count	Number of intermediate positions for one position.	
Splash delta (µm)	Distance between intermediate positions.	
Connect	Connect to the machine.	
Start	Start the measurement.	These buttons appear when you connect to the machine.
Stop	Stop the measurement.	
Disconnect	Disconnect from the machine.	
Calibrate	Calibrate the machine.	
	Settings (calibration and templates).	

10.4.2. Calibration



Attention!
The machine must be calibrated by using the calibration pipe every time when you switch it on.

To perform the calibration procedure, follow the steps below:

- Insert the calibration pipe into the V-block.
- Go to the main window.
- Select **Calibration** from a drop-down list:

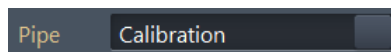

- Connect to the machine - click **Connect**.
- Start the calibration process - click **Calibrate**.
- Wait until the calibration is complete.

Calibration settings can be changed. Click **Disconnect**, then click  on the left side of the main window, and go to the **Calibration** tab.

The **Calibration** tab:

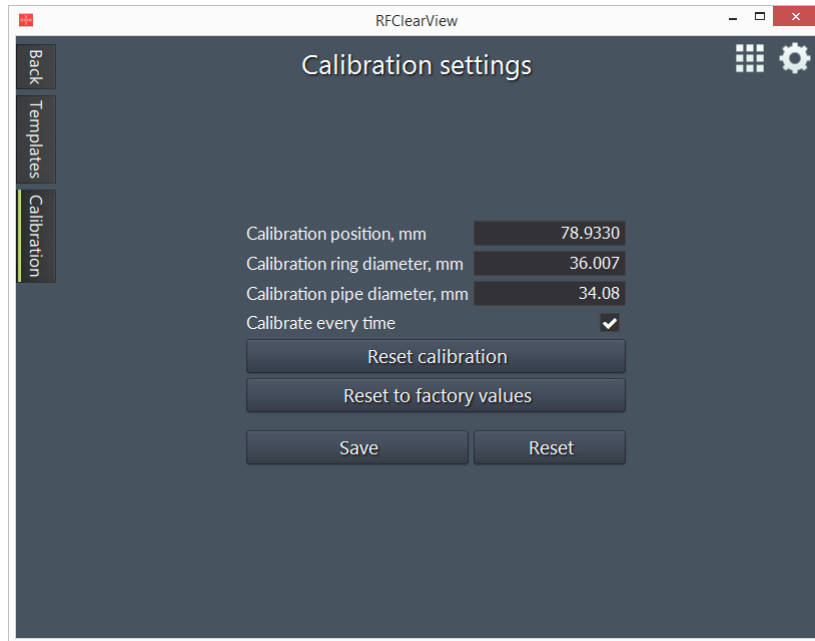

You can use the default calibration parameters or set them manually (if necessary).

If you have changed the parameter value and did not click **Save** yet, you can reset this change by clicking the **Reset** button.

To restore the default values of all calibration parameters, click **Reset to factory values**.

The calibration by using the calibration pipe is necessary. Optionally, you can also calibrate the machine by calibration ring. Options **Reset calibration** and **Calibrate every time** are applied only to the calibration by ring. In case of the calibration error, click **Reset calibration**. To calibrate the machine by ring every time before measurement, select the **Calibrate every time** option.

To save the changes, click **Save**.

Click **Back** to return to the main window.

Note. Do not click **Back** and **Templates** before you have saved calibration settings, because in this case all changes will be reset.

10.4.3. Measurement procedure

Once the system has been calibrated by using the calibration pipe, it's ready to work. To perform the measurement, follow the steps below:

1. Select the pipe from the **Pipe** drop-down list (how to create pipe descriptions, see Par. [10.4.4.](#)).
2. Select the **Write log** option (if necessary).
3. Click **Connect**.
4. Insert the pipe into the V-block (the pipe must be pressed to the thrust plate).
5. Click **Start** (or press the foot switch).



When you click **Stop** during the measurement process and then click **Start** again, the measurement will be repeated from the beginning.

Upon completion of the measurement process, a signal tower blinks green or red (depending on the final result: green – success, red – fail), and the program displays the measurement results as shown on the screenshot below:

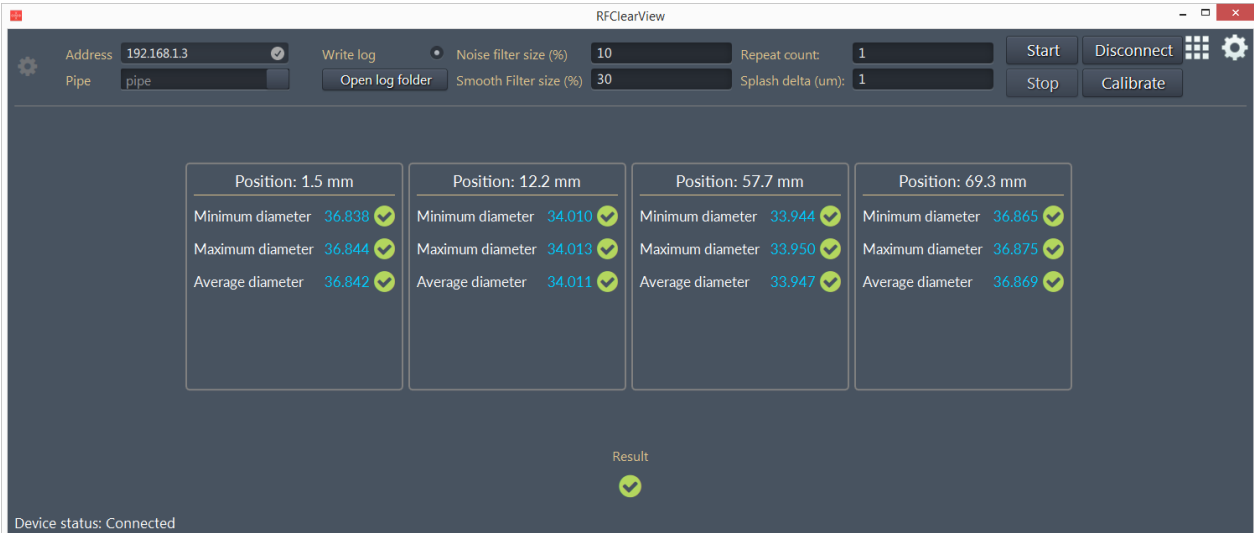

Pass  - measurement results are within the tolerances.

Fail  - measurement results are beyond the tolerances.

The final result is shown below the tables (**Result**).

Take note that the final result can be **Pass** or **Fail** depending on the following:

Minimum diameter	Maximum diameter	Average diameter	Result
Fail	Fail	Fail	Fail
Fail	Fail	Pass	Fail
Fail	Pass	Fail	Fail
Fail	Pass	Pass	Fail
Pass	Fail	Fail	Fail
Pass	Pass	Fail	Pass
Pass	Fail	Pass	Pass
Pass	Pass	Pass	Pass

Next, if you intend to measure pipes of the same type, change the pipe in the V-block (see step 4), and click **Start**.

If you want to change the pipe type, it is necessary to disconnect from the device (click **Disconnect**), and to follow steps 1-5.

If you want to change settings, it is necessary to disconnect from the device (click **Disconnect**), and to click  on the left side of the main window.

10.4.4. Templates settings

Click  on the left side of the main window.

When there are no saved pipe descriptions in the program, the program prompts to create one:

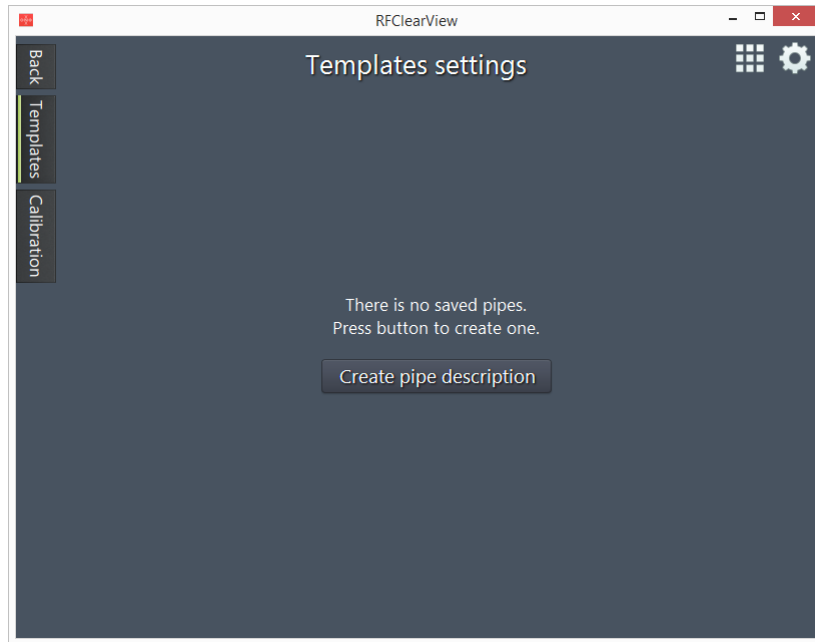

Click **Create pipe description**, enter the name into the **Pipe name** field, and click **Ok**.

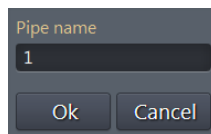

When the pipe description is created, it is necessary to add the measurement positions and to set tolerances for each of them.

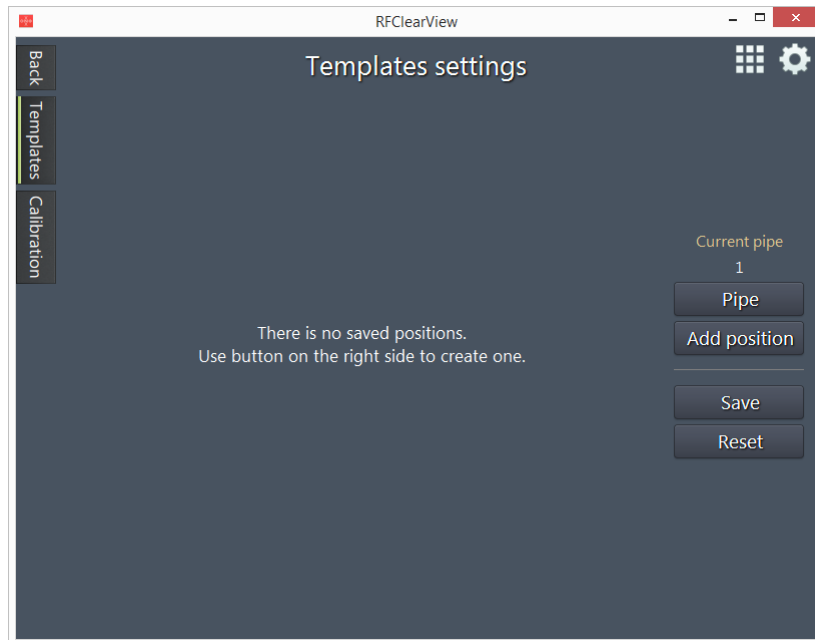

For every pipe you must set at least one measurement position. To add the measurement position, click **Add position**.

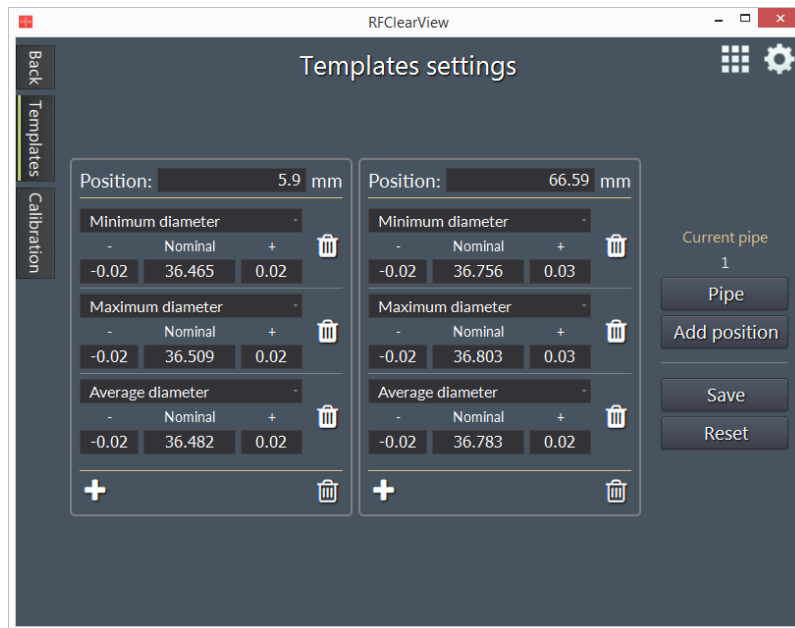

Next, it is necessary to set parameters for every position:

- Measurement position: the **Position** field (mm)
- Tolerances: Minimum, Maximum and Average diameter (mm)

It is necessary to set tolerances (-/+) and a nominal value (the **Nominal** field) for the selected diameter.

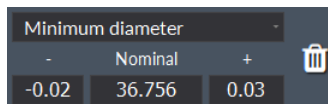

To remove the tolerances, you need to click next to the ones you want to remove.

To add the new tolerances, you need to click .

To remove the position, click in the bottom part of the position area.

When you have set all parameters, click **Save** to save the pipe description.

Note. Do not click **Back** and **Calibration** before you have saved the pipe description, because in this case all changes will be reset.

If you want to create a new pipe description, click **Pipe** > **Add pipe**, enter the name into the **Pipe name** field, and click **Ok**.

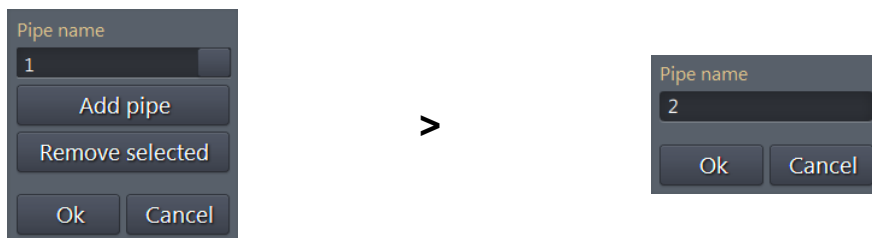

If you want to remove the pipe description, click **Pipe**, select one from the list, click **Remove selected**, and confirm the action.



To pass to another pipe, click **Pipe**, select one from the list, and click **Ok**.

When you have set all parameters and saved the pipe description, click **Back** to return to the main window in order to start the measurement.

10.4.5. Log

To save results to the log files (CSV), select the **Write log** option. To open the log folder, use the special button:

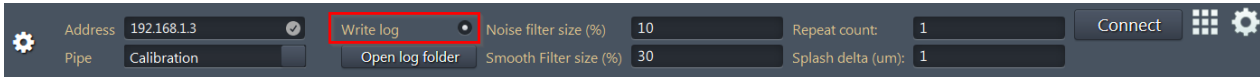

You can select the **Write log** option only when the device is not connected in the program.

11. Troubleshooting

Problem	Cause	Solution
You can not connect to the device in the program	Device is turned off	Make sure that the device is turned on (red button on the controller).
	Power supply	Check the power supply.
	Cables	Make sure that all cables are connected properly.
	Subnet conflict	Check network settings. The device and your PC must be in the one subnet.
Incorrect results	Calibration error	Check calibration parameters . Recalibrate the machine by using the calibration pipe.
No log files	Program settings	Make sure that the Write log option is enabled.

12. Technical support

Technical assistance, related to incorrect work of the device and to problems with the service program, is free. Requests for technical assistance should be addressed to support@riftek.com, or by phone +375-17-2813513.

When contacting technical support, please provide the detailed description of the problem.

13. Warranty policy

Warranty assurance for the Pipe Inner Diameter Measurement Machine RF096-32/42-80 Series – 24 months from the date of putting in operation; warranty shelf-life – 12 months.

Warranty repair is not provided in the cases of incorrect connection and mechanical damage, including opening the housing.