DESIGN MANUAL
INSTALLATION -- OPERATION -- MAINTENANCE
SERVICE MANUAL

MODEL GT812
NOVA-SENSOR *ELITE*[™]
TOXIC GAS DETECTOR

70099



The information and technical data disclosed by this document may be used and disseminated only for the purposes and to the extent specifically authorized by Safety Systems Technology in writing. Such information and technical data are proprietary to Safety Systems Technology and may not be used or disseminated except as provided in the foregoing sentence.



Blank Page

Quick Finder

MODEL GT812

NOVA-Sensor ELITE™ Toxic Gas Detector

DESCRIPTION	812-1
TECHNICAL SPECIFICATIONS	812-2
SELECTING A LOCATION FOR THE GAS DETECTOR	812-3
“ONE HOUR” INSTALLATION INSTRUCTIONS	812-4
1. MOUNT THE DETECTOR ELECTRONICS ENCLOSURE	812-4
2. MOUNTING THE REMOTE GAS SENSOR HEAD	812-4
3. OPEN THE DETECTOR HOUSING AND REMOVE ELECTRONICS MODULE	812-4
4. CONNECT EXTERNAL SENSOR HEAD TO THE DETECTOR	812-5
5. CONNECT POWER AND ANALOG SIGNAL WIRING	812-5
6. CONNECT OPTIONAL REMOTE RESET SWITCH	812-6
7. CONNECT RELAY CONTACTS TO EXTERNAL EQUIPMENT	812-6
8. SET RELAY CONTACT JUMPERS	812-6
9. SET LOW ALARM RELAY CONTACT FOR LATCHING OPERATION	812-7
ROUTINE OPERATION OF THE NOVA-Sensor ELITE	812-7
PROTECTION MODE	812-7
LOW GAS ALARM MODE	812-7
HIGH GAS ALARM MODE	812-8
FAULT MODE	812-8
MAINTENANCE REMINDER MODE	812-9
MAINTENANCE	812-9
MONTHLY “BUMP” TESTS	812-9
RECALIBRATION SCHEDULE	812-9
RECALIBRATION INSTRUCTIONS	812-10
REPLACING THE ELECTRO-CHEMICAL FUEL CELL SENSOR ELEMENT	812-11
CALIBRATING TO A DIFFERENT TARGET GAS	812-12
CHANGING THE FULL SCALE MAXIMUM READING	812-12
RECALIBRATING THE SENSOR HEAD	812-12
SPARE PARTS & RECOMMENDED TEST EQUIPMENT	812-13
TROUBLESHOOTING	812-14
CHECK CALIBRATION MESSAGE	812-14
SYSTEM FAULT MESSAGE	812-14
OTHER CALIBRATION MESSAGES	812-14
DRIFTING OR UNSTABLE PPM READINGS	812-14
FALSE ALARMS	812-14
TRANSIENT INTERFERENCE OR POWER SURGES	812-15
WARRANTY INFORMATION	812-15

Blank Page

MODEL GT812 NOVA-Sensor *ELITE™* Toxic Gas Detector

DESCRIPTION



*Model GT812 Toxic Gas
Detector*

Use the NOVA-Sensor *ELITE* Toxic Gas Detector to alert personnel when life-threatening gas is present in a protected area. This detector uses an electrochemical fuel cell sensing element, and provides accurate measurements in all atmospheres. A high reserve of electrochemical activity insures a long life and excellent temperature stability. The performance is relatively unaffected by humidity, providing that conditions are non-condensing,

The display screen on the NOVA-Sensor *ELITE* continuously displays operating status and the actual concentration of toxic gas in parts per million (PPM). This reading is converted to a standard 4-20 mA signal, which may be connected to any remote device for remote display or logging. Relay contacts are provided which transfer when the gas concentration exceeds the LOW ALARM and HIGH ALARM set points. Typical set points are adjusted by the installer upon installation and may be reset later by authorized personnel. The relays are suitable for controlling local HVAC equipment, alarm signal devices or for equip-

ment shutdown. Fault relay contacts are also available which operate upon loss of power or internal failure of the unit.

The automatic calibration sequence is initiated by depressing the pushbutton switch located on the side of the enclosure. During calibration, step-by-step instructions are displayed on the NOVA-Sensor screen. There are no screwdriver or other manual adjustments required, and the calibration can be performed even in the presence of toxic gases.

TECHNICAL SPECIFICATIONS

Power Input	24 volts DC nominal, 80 mA standby, 140 mA alarm. Operates within specifications from 16 to 32 volts.
Full scale measuring range ..	10, 20, 50, 100, 200 or 500 PPM (parts per million)
Operating Temperature	-22 to +122°F (-30 to +50°C) H ₂ S -4 to +122°F (-20 to +50°C) SO ₂ and CL ₂ -4 to +131°F (-20 to +55°C) CO -13 to +131°F (-25 to +55°C) NH ₃ All sensors may be operated intermittently up to +150° F.
Relative Humidity	15% to 90% non-condensing; 0 to 99% intermittently
Ingress Protection:	IP40 to IP66. Depends on installed protection options.
Zero Drift:	Less than ±0.1 PPM per month
Sensitivity Drift:	Less than 2% change per month
T90 Response Time:	Less than 20 seconds
Accuracy:	Linear response 0 to 20 PPM. Full scale error ±6 PPM.
Fuel Cell Life:	2 years. Plug-in replacement at end of life.
Relay Outputs:	Low Alarm, High Alarm, Malfunction
Relay Contact Ratings:	6 amps @ 28 VDC or 300 VAC resistive 1/8 HP @ 120/240 VAC
Analog Output:	0 to 20 mA into a load of 600 ohms or less
Conduit Connection:	¾ inch NPT thread.
Weight:	6.25 pounds (2.83 kg)
Electronics Enclosure	Class I Division 1 Groups B,C,D Class I Zone 1 AEx d IIC, IP66 DEMKO 01ATEX015742U II 2 GD Ex dIIC IP66 -20°C to +60°C

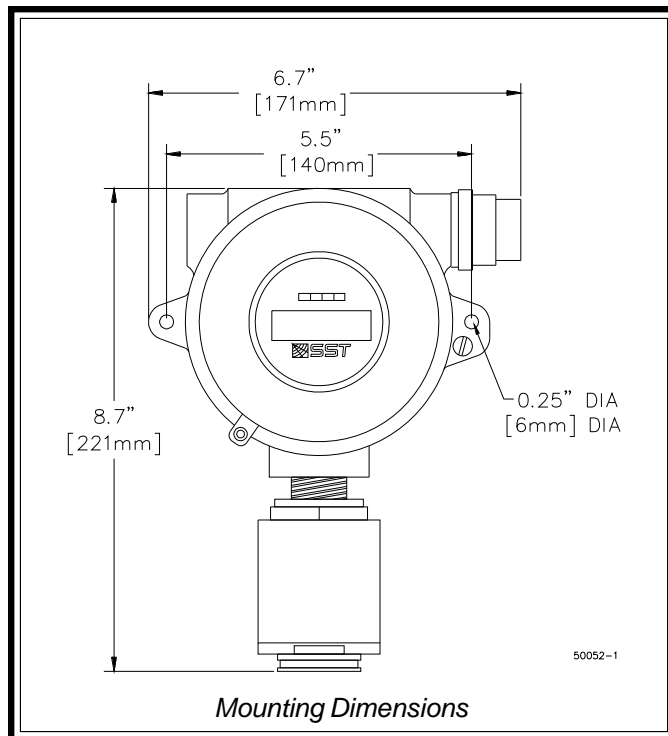

SELECTING A LOCATION FOR THE GAS DETECTOR

To insure the fastest possible detection of leaking gases, the location of the sensor is important. Lighter than air gases tend to accumulate at the highest point in an enclosed space, whereas heavier than air gases will accumulate at the lowest point in the room. For sensors located out of doors or in very large enclosed spaces, try to locate a sensor near any expected source of leaks (such as pumps, valves or pipe fittings), taking the gas weight into consideration.

Also consider the effect of wind or forced air cooling at the sensor location. The gas sensor will never respond if air currents blow the gas away from the sensor.

Preferred orientation of the sensor is with the porous face of the sensor pointing down, as shown in the pictures. If necessary, it may be installed at an angle or horizontally. The sensor must never be installed pointing upwards.

Lighter than air toxic gases (sensor mounted above leak point)

For lighter than air gasses, the sensor should be located above the spot where a leak is likely or at the highest point within an enclosure.

Symbol	Toxic Gas	Density	TWA	STEL
NH ₃	Ammonia	0.6	25	35
HF	Hydrogen Fluoride	0.9		3

Gases with weights near that of air (Density of air = 1.00)

These gases mix readily with air, so sensor location is not as critical, but sensor should still be near the expected leak point for fastest response.

Symbol	Toxic Gas	Density	TWA	STEL
CO	Carbon Monoxide	1.0	25	
NO	Nitric Oxide	1.04	25	

Heavier than air toxic gases (sensor mounted below leak point)

For heavier than air gasses, locate the sensor below the expected leak. However, do not locate the sensors closer than 1 foot to a floor to prevent damage from water, dust, etc.

Symbol	Toxic Gas	Density	TWA	STEL
H ₂ S	Hydrogen Sulfide	1.2	10	15
C ₂ H ₄ O	Ethylene Oxide (ETO)	1.5	1	
NO ₂	Nitrogen Dioxide	1.6	3	5
SO ₂	Sulfur Dioxide	2.25	2	5
CL ₂	Chlorine	2.5		

! NOTE: Data in above tables is from reliable sources that are believed to be accurate, but is not guaranteed by Safety Systems Technology. **TWA** is the *Time Weighted Average* gas concentration in PPM to which personnel may be repeatedly exposed without adverse effects. **STEL** is the *Short Time Exposure Limit* gas concentration to which personnel can be exposed for a short time without suffering irritation, irreversible tissue damage, unconsciousness or paralysis.

“ONE HOUR” INSTALLATION INSTRUCTIONS

The Model GT812 Toxic Gas Detector is shipped fully assembled and pre-calibrated to the full scale range of toxic gas that you have specified with your order. It can be installed and be fully operational in less than one hour. Various protection accessories required for use in hostile environments are already installed on some detectors.

1. Mount the Detector Electronics Enclosure

Secure the electronics to a wall or bracket, using bolts through the two mounting holes. Locate the unit at a convenient place where the viewing screen and LED's can be easily seen through the window on the front of the enclosure. Most NOVA-Sensor *ELITE* detectors are shipped with the sensor pre-installed onto the electronics housing as shown here.



Electronics Enclosure

2. Mounting the Remote Gas Sensor Head

For 2-piece gas sensors only, mount the remote sensor in the location chosen for best and fastest response to leaking gas, as explained on the previous page. Lighter than air gases, sensor mounts on or near ceiling of enclosure. Heavier than air gases, sensor mounts about 1 foot (30 cm) above floor or ground. Preferred orientation is with the porous metal sensing face pointed downward. Never point the sensor face upward to insure that no moisture or dust collects on the sensor face to reduce sensitivity and damage the sensor.



Remote Sensor

3. Open the Detector Housing and remove Electronics Module



Cover Lock Screw

Loosen the hex head set screw on detector cover (a 7/64 inch or 2.5 mm hex wrench is required) and turn cover counter clockwise to remove.

Use a small screwdriver inserted under the edge of the electronics module in the 3 locations marked “pry up” to loosen the module from the connector and remove it from the enclosure.

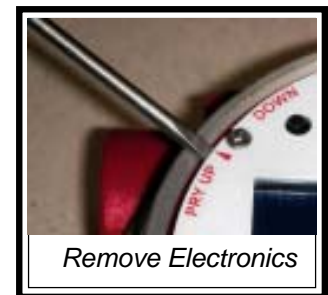

Remove Electronics

4. Connect external Sensor Head to the Detector

The sensor head, if installed on the electronics housing, is pre-wired to the NOVA-Sensor *ELITE* electronics by SST at the factory. If remote sensor is used, two conductors are required between the sensor and the electronics. These wires will carry a maximum of current of 20 mA at 32 volts DC, so large wires are not required. We recommend using size 22 AWG or 0.35 mm² conductors, colored red and black.

IMPORTANT: Any electrical conduit connected to the NOVA-Sensor *ELITE* electronics enclosure must have a conduit seal installed within 18 inches (45.7 cm) of the enclosure.

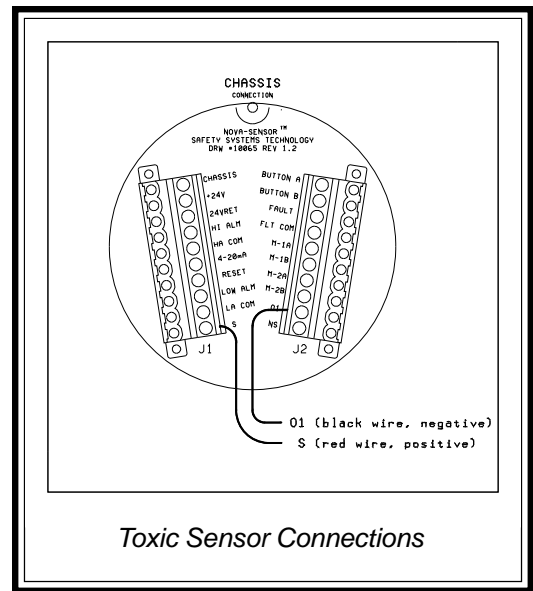

Toxic Sensor Connections

5. Connect Power and Analog Signal Wiring

A typical installation is shown in this drawing. This setup uses three wires between the NOVA-Sensor *ELITE* and the associated control modules. These wires carry the 24 VDC operating power for the sensor, and transmit the 20 mA signal to the controls. The wires should be shielded (screened) or installed in metal conduit to prevent undesirable noise pickup. Note that the black wire shown in the drawing provides the return path for both the 24 volt operating power and the 4-20 mA analog output.

IMPORTANT: Any electrical conduit connected to the NOVA-Sensor *ELITE* electronics enclosure must have a conduit seal installed within 18 inches (45.7 cm) of the enclosure.

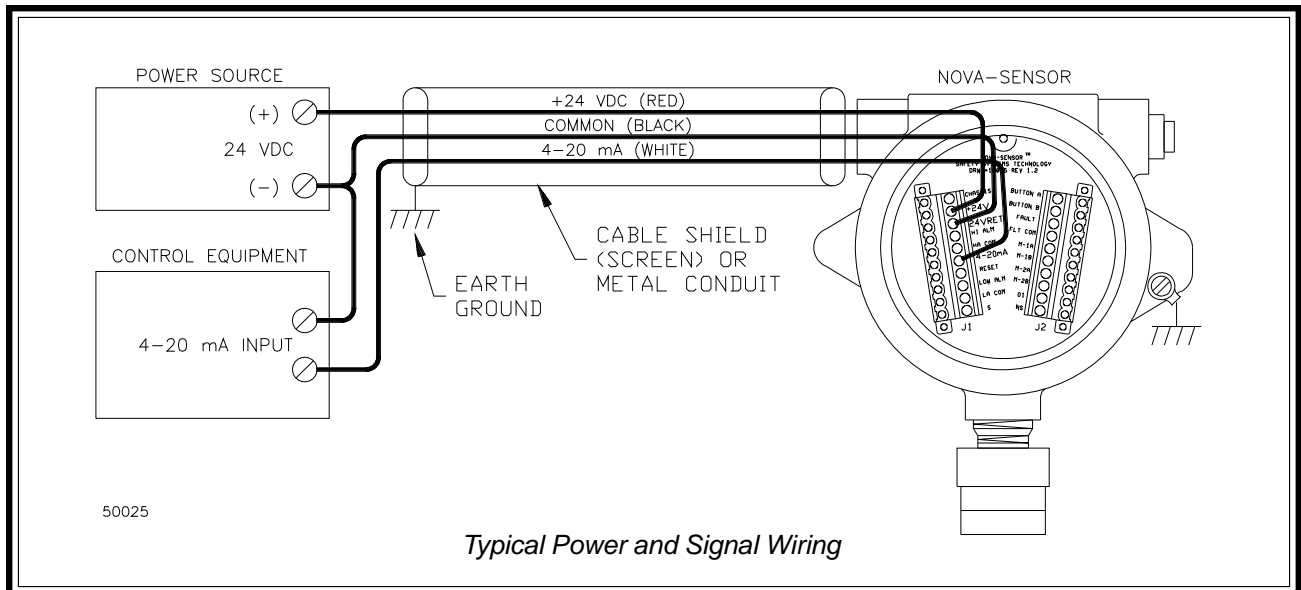

Typical Power and Signal Wiring

6. Connect optional Remote RESET Switch

The integral MODE pushbutton on the NOVA-Sensor *ELITE* housing can be used to clear any relays or alarms in the NOVA-Sensor *ELITE* which have been latched when activated. Pressing the button will cause the latched relays to clear. The alarm setpoints will also be momentarily displayed.

An optional remotely located pushbutton switch can be wired to the terminal marked RESET. This should be a normally open contact, and should connect the reset terminal to 24VRET (COMMON) to reset the detector when actuated. The remote RESET button, when active for 1 to 3 seconds will clear any latched relays.

7. Connect Relay Contacts to external equipment

The internal alarm and fault relay contacts can be used to provide signals to other pieces of equipment. Typical applications would be to activate audible and visual alarm signals to alert personnel in the local area. Or these contacts may be used to shut down critical equipment or to report conditions to a data logging system. These contacts may be set to be either normally open (NO) or normally closed as described below.

Connect 2 wires between external equipment and each of the below listed terminal pairs.

LOW ALM / LA COM	Contact transfers when LOW Alarm setpoint is reached
HI ALM / HA COM	Contact transfers when HIGH Alarm setpoint is reached
FAULT / FLT COM	Contact transfers detector is in a FAULT condition

8. Set Relay Contact Jumpers

Jumpers on the detector electronics module lower most circuit board allow relay contacts to be set as normally open or normally closed.



Low Alarm Jumper

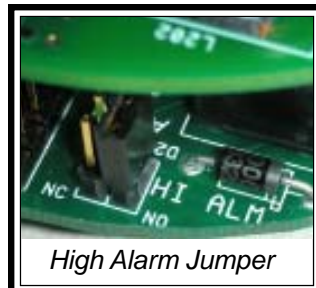

High Alarm Jumper

Low and High Alarm Relay Contacts

The factory jumpers are shipped connecting the 2 **NO** pins together. Contacts will be open when there is no gas alarm, and will close when a low or high gas alarm is detected.

Remove jumper plug from the NO pins and reinstall on NC pins to set this contact to be normally closed.

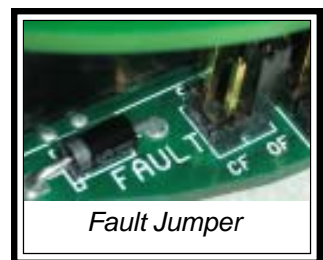

Fault Jumper

Fault Relay Contacts

The factory jumper is shipped connecting the 2 **OF (Open on Fault)** pins together. The fault contact will be closed when there is no fault detected in the gas detector. The fault contact will open when any internal fault condition occurs in the gas detector. The fault contact will also open if the 24 volt DC power supply to the detector is interrupted.

Remove jumper plug from the OF pins and reinstall on **CF (Closed on Fault)** pins to set the fault contact to close when a fault or loss of power is detected.

! There are two additional jumpers factory installed at the positions marked "**TOX**". Do not remove or change these jumpers nor move them, as they are required for proper operation of this detector.

9. Set Low Alarm Relay Contact for Latching Operation

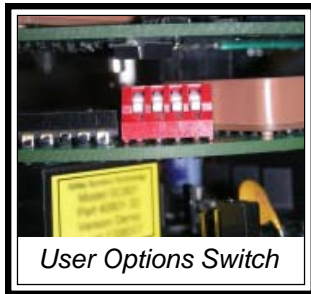

User Option Switch number 4 sets the operation of the LOW alarm LED and relay.

Switch 4 DOWN sets Low Alarm NON-LATCHING. The low alarm will automatically reset whenever the gas level falls below the set point.

Switch 4 UP selects LATCHING mode for the LOW alarm. You must press the MODE button on the detector housing or use the remote RESET input to clear the alarm.

Note: The HIGH Alarm is always latching and cannot be set to non-latching mode.

User Options Switch 1, 2 and 3 are preset at the factory to match the factory calibration of your NOVA-Sensor *ELITE*. **Do not change** these switches unless you are recalibrating the detector for a different full scale range. Refer to Calibration Instructions in this manual.

ROUTINE OPERATION OF THE NOVA-Sensor *ELITE*

The NOVA-Sensor *ELITE* is designed to provide protection of personnel and property from gas leaks 24 hours a day, 7 days a week with no regular intervention required.

Protection Mode

This is the normal operating mode, and the NOVA-Sensor *ELITE* will be in this mode when all conditions are normal. The lighted blue background on the display screen will be dimmed to conserve power, but the digital display of the actual concentration of the target gas will be readable, even if the detector is located outdoors in bright sunlight. The green POWER indicator will be illuminated, and will occasionally blink as a confirmation that the microprocessor is continuing to check the area for gas.

In protection mode, all relay contacts are in the normal, non-alarm and non-fault condition, and the detector will transmit a 4.0 mA signal to any connected external equipment.

Press and release the button on the side of the enclosure to:

- Restore the screen illumination to full brightness
- Display the gas concentration that will activate the LOW ALARM
- Display the gas concentration that will activate the HIGH ALARM
- The detector will then return to normal operation.

Low Gas Alarm Mode

When gas is starting to accumulate in the protected area, the following occur:

- The present gas concentration is displayed (The screen will remain at half brightness during this time)
- The 4-20 mA signal to external equipment increases to report the present gas concentration
- When gas concentration reaches the low alarm set point, the SCREEN FLASHES and the red LOW ALARM indicator also flashes.
- The low alarm relay is activated

! A typical application might use this low alarm relay contact to activate an exhaust fan to try to remove the leaking gas from this location.

- If gas concentration goes down below the low alarm set point, the red alarm indicator is extinguished and the screen stops flashing, but remains at full brightness until the gas concentration returns to zero.
 - ! If the red alarm indicator and the screen do not stop flashing when the gas concentration is below the low alarm set point, the detector has been configured with a latching low alarm. In that case, you must push the button on the side of the detector to cancel the low alarm and return the detector to the protection mode. The low alarm may also be canceled from a remote location if the reset function has been installed in your detector..
- At zero gas concentration, the screen returns to half brightness and the detector returns to normal protection operation.

High Gas Alarm Mode

If the gas concentration continues to increase above the low alarm setpoint, the following occur:

- The present gas concentration is displayed (The SCREEN FLASHES and the LOW ALARM indicator will remain flashing during this time due to the low gas alarm)
- The 4-20 mA signal to external equipment increases to report the present gas concentration
- When gas concentration reaches the high alarm set point, the red HIGH ALARM indicator also flashes.
- The high alarm relay is activated
 - ! A typical application might use this high alarm relay contact to shut down all electrical equipment in the protected area and activate evacuation alarm signals to alert personnel.
- A high gas alarm condition is always locked in or “latched” in the detector, and the high alarm indicator and the screen will continue to flash even after the gas concentration has returned to zero.
- Push the button on the side of the detector to cancel the high alarm and return the detector to the protection mode. The high alarm may also be canceled from a remote location if the reset function has been installed in your detector.

Fault Mode

The NOVA-Sensor *ELITE* is designed to continually monitor it's own operation and to alert personnel when it is not functioning properly. This condition is reported as a FAULT. When a fault condition is active, the following occur:

- The SCREEN FLASHES and displays SYSTEM FAULT, and the yellow FAULT indicator flashes (if failure is not due to power source failed)
- The 4-20 mA signal to external equipment decreases to 2.0 mA or 0.0 mA
- The fault relay contact to external equipment changes state

! While in fault mode the NOVA-Sensor *ELITE* might not be able to report an alarm condition. The source of fault conditions should be corrected as soon as possible for safety reasons.

Possible causes of a Fault

Electrochemical fuel cell in the sensor head is past the rated 2 year operating life
 Sensor head failure due to intrusion of moisture, dust, or silicones
 Sensor failure due to exposure to extremely high concentrations of gas for an extended period of time
 An open-circuit or short-circuit on the wiring going to a remote sensor
 24 volt DC power source out of range or failed
 Failure of the electronic circuits inside the NOVA-Sensor *ELITE* itself

Maintenance Reminder Mode

We recommend a monthly test of the NOVA-Sensor *ELITE* as explained in the Maintenance section of this manual. The following reminders may be displayed when additional service is recommended:

- If the sensor display is showing negative gas values of -5 or lower, CHECK CALIBRATION is displayed on the screen. (The screen illumination will remain dim during this display)
- If the sensor display is showing negative gas values of -10 or lower, SYSTEM FAULT will display, the screen back light will flash and the yellow FAULT indicator will flash.
- 90 days after the last full calibration was made, CHECK CALIBRATION is displayed.
- After the sensor fuel cell element has been in service for 2 years, the detector will display REPLACE SENSOR CELL as a reminder that the cell is losing sensitivity. After replacing the fuel cell with a new one, hold the UP button depressed for about 2 seconds. The display will read SERVICE ADVISORY CLEARED, and the unit is ready for another 2 years of operation. Because the sensor cell has been changed, you should now recalibrate the detector to the new sensor cell.

MAINTENANCE

Monthly “Bump” Tests

We recommend that a short performance test be performed at least every 30 days to verify that your NOVA-Sensor *ELITE* is operational. This is commonly called a Bump Test in the industry. During this test, you expose the detector to a small amount of test gas, just enough to see that the sensor is reading the gas concentration. It is not necessary to perform a complete recalibration of the detector.

During the bump test all of the detector’s outputs (analog and relay contacts) may be activated. Before starting, notify affected personnel and bypass any shutdowns if required.

The rated maximum reading for your NOVA-Sensor is continuously displayed at the upper right corner of the screen, such as **100 PPM**, and the target gas is shown on the lower line of the display, such as **HYDROGEN SULFIDE**. For the bump test, use the target gas mixed with air at a concentration not greater than the rated maximum PPM.

Expose the sensor head to the bump gas. Watch for the concentration readings to be displayed on the detector screen. You do not need to continue beyond this point, you just want to be sure that there is a response. If you have test gas with concentrations higher than the alarm trip points, you may leave the gas on until they activate if desired.

Recalibration Schedule

The NOVA-Sensor *ELITE* has been pre-calibrated to the target gas at the factory, and no further calibration will normally be required when it is initially installed. Under normal operating conditions, SST gas detectors should be recalibrated every 90 days. However, the change in calibration over time is a function of how much “background” gas is present during normal operation, and how often the detector is exposed to higher concentrations. When the gas sensor is initially installed, we recommend that the calibration be checked on a more frequent basis to determine how much the calibration is changing. To check, expose the detector to the same calibration gas as was used for the original calibration. Use the data taken over several tests to determine how often you should recalibrate the detector to keep the desired accuracy.

90 days after the last calibration of the detector was made, the message CHECK CALIBRATION will be displayed on the screen. This will not effect the normal operation, and the NOVA-Sensor will continue in normal protection mode using the existing calibration data. However, the calibration data should be refreshed as soon as practical, using the instructions below.

Recalibration Instructions

Calibration will take care of changes in sensor performance and drift. The automatic calibration procedure provides the NOVA-Sensor *ELITE* with reference points needed to accurately measure gas levels. During the calibration procedure, clean air as well as calibrated test gas are applied to the detector. If clean air cannot be assured, you may need to “purge” the sensor with clean air from a gas bottle. DO NOT USE Nitrogen to purge the sensor, false readings may result!

The calibration can be performed by one person with the NOVA-Sensor *ELITE* operating in the hazardous area. No manual adjustments are required for calibration.

! Calibration gas with a concentration of exactly one-half of the rated full scale of the NOVA-Sensor *ELITE* mixed with air is required for the calibration procedure. The rated maximum reading for your NOVA-Sensor is continuously displayed at the upper right corner of the screen, such as **100 PPM**, and the target gas is shown on the lower line of the display, such as **HYDROGEN SULFIDE**. For calibration, the target gas must be mixed with air concentration must be one-half of the full scale rating. (e.g. 50 PPM balance air calibration gas for a 100 PPM toxic gas detector).

Calibration Procedure

The calibration procedure is initiated by depressing and holding depressed the MODE push-button located on the side of the detector enclosure. This will start the sequence of easy calibration instructions displayed on the screen, as listed below. (Messages are as shown below when calibration a 100 PPM H₂S detector.)

1. **HOLD FOR CALIBRATION MODE** while button is depressed.
2. **TO START CALIBRATION RELEASE BUTTON NOW.**
3. **CALIBRATION MODE FINDING ZERO...WAIT** storing zero reference point
! **WARNING:** If sensor is exposed to any toxic gases during this step, the calibration will not be correct.
4. **CHECK GAS PRESSURE ... APPLY 50 PPM HYDROGEN SULFIDE** waiting for test gas
! **WARNING:** If calibration gas cylinder pressure is below 300 PSI [20 bars], there may not be enough gas in the cylinder to accurately calibrate the detector. Abort calibration immediately by pressing mode button 2 times. Calibration will not be correct if you continue calibration procedure with insufficient gas.
5. **GAS DETECTED...WAIT** measuring the test gas concentration
6. **REMOVE GAS...WAIT** to allow test gas to dissipate from inside of sensor
7. **CALIBRATION COMPLETE** calibration data saved for use until next calibration
8. **0% PPM HYDROGEN SULFIDE** NOVA-Sensor *ELITE* returns to normal operation

During the calibration process, the 4-20 mA output is set to 2 mA and the relay outputs will not be activated.

Failed or Incomplete Calibrations:

The NOVA-Sensor *ELITE* will wait for up to 5 minutes for gas to be applied during the calibration procedure. If no gas is detected within the 5 minutes, the calibration will be aborted and the message CALIBRATION FAILURE, USING PRIOR CALIBRATION DATA is displayed. The NOVA-Sensor *ELITE* will then return to normal operation.

- You may abort or cancel a calibration procedure at any time by momentarily depressing the MODE button 2 times. The message CALIBRATION CANCELED, ORIGINAL VALUES WILL BE USED is displayed. You may also abort the calibration by interrupting the 24 VDC power to the detector.

Possible causes for incomplete calibration are:

- 1) Gas sensor head failure due to liquid intrusion.
- 2) Gas detector electrochemical fuel cell electrolyte may have been completely consumed by exposure to an extremely high concentration of toxic gas over a very long time period.
- 3) Gas detector electrochemical fuel cell electrolyte may have been completely dried out by exposure to extremely low relative humidity over a very long time period.
- 4) Calibration gas applied at wrong time. Gas applied during step 3 above (i.e. too early, during clean air sampling) will result in negative displays and inaccurate readings. If the gas is applied too late (which may occur due to the pipe length when remote sensors are used) it may not reach significant levels before the 5 minute time-out.

Replacing the Electrochemical Fuel Cell Sensor Element

After extended use, the sensing element may age to the point where it will no longer be able to calibrate properly. This will be indicated by a FAULT after performing a calibration.

- After the sensor fuel cell element has been in service for 2 years, the detector will display REPLACE SENSOR CELL as a reminder that the cell is losing sensitivity. After replacing the fuel cell with a new one, hold the UP button depressed for about 2 seconds. The display will read SERVICE ADVISORY CLEARED, and the unit is ready for another 2 years of operation.

Replacement sensor elements are available from Safety Systems Technology. Ordering information is in the section headed SPARE Parts. The element is supplied preinstalled on a small circuit board and is calibrated at the factory to provide a 4-20 mA signal output at the proper sensitivity for your NOVA-Sensor.

To replace the sensor, loosen the set screw on the front of the sensor head housing and unscrew the cover from the sensor head. Note the location of the Red and Black wires connected to the terminal block on the existing sensor. Loosen the two screws on the terminal block and remove the two wires. If the power to the NOVA-Sensor *ELITE* is still on, be sure that the ends of the two wires do not touch each other or the metal housing.

Connect the red and black wires to the proper terminals on the new sensor, position the sensor inside of the housing and replace the sensor cover. Tighten the set screw.

Depress and hold the MODE pushbutton on the NOVA-Sensor to start the calibration sequence. This will recalibrate the detector to the new sensor.

Calibrating to a different Target Gas

Your NOVA-Sensor *ELITE* includes internal parts that are specific to the target gas that it displays. It is not possible to use this detector to monitor for any other toxic gas unless the detector is returned to the factory for rebuilding.

Changing the Full Scale Maximum Reading

The NOVA-Sensor *ELITE* sensitivity may be changed following the instructions below. After changing the sensitivity, you must recalibrate the detector sensing head and the NOVA-Sensor electronics module.

! Changing the sensitivity without recalibration will result in incorrect readings which could be unsafe for use.

To change the calibration gas, follow these instructions.

1. Loosen the front cover set screw and remove the front cover. Unplug the electronics module and locate the User Options Switch. Option switches number 1, 2 and 3 set the full scale sensitivity of the Toxic Gas NOVA-Sensor.

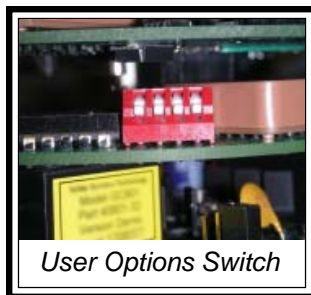

Sensitivity	Switch 1	Switch 2	Switch 3
10 PPM	Up	Down	Down
20 PPM	Down	Up	Down
50 PPM	Up	Up	Down
100 PPM	Down	Down	Up
200 PPM	Up	Down	Up
500 PPM	Down	Up	Up

2. Replace the electronics module and front cover on the detector.
3. Recalibrate the sensor head to the new sensitivity following the instructions below.

Recalibrating the Sensor Head

This procedure is required only when you are changing the PPM sensitivity of the NOVA-Sensor *ELITE*. Calibration requires access to the potentiometers on the transmitter PC board located inside the sensor head housing. Loosen the set screw on the cover and unscrew the cover from the sensor housing to locate these pots.

! If the sensor is installed in a hazardous area, be sure that no combustible gasses are present before the front cover is removed from the housing.

For calibration purposes, the signal must be monitored using a standard milliammeter inserted into the 4-20 mA circuit. Disconnect the red wire from the PC board and connect the meter between the red wire and the open terminal on the PC board. To adjust the potentiometers a small screwdriver is required. Perform the following procedure to calibrate the sensor/transmitter combination:

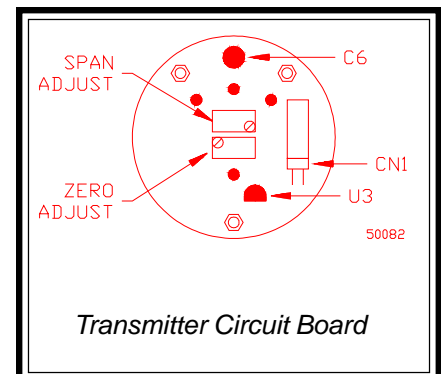

1. Ensure the sensor is free from the gas being measured either by purging the sensor with pure air if necessary.
2. Adjust the ZERO potentiometer until 4.0 mA output is obtained. Turn the zero pot counter clockwise to increase the output.
3. Apply a test gas whose known concentration is one half of the desired full scale reading to the sensor. (For instance, apply 25 PPM gas to a sensor that is to be calibrated to read 0 to 50 PPM Toxic Gas.)
4. Wait for a stable reading to be obtained. This could require up to five minutes, although required time is usually much shorter.
5. Adjust the SPAN potentiometer until the current drawn by the sensor is exactly 12.0 mA. Turn the span pot counter clockwise to increase the output.
6. Remove gas, allow sensor output to decrease to a constant value. If this is not 4.0 mA, readjust the ZERO pot for 4.0 mA, then repeat steps 3 through 6 until there is no change in the 4.0 and 12.0 mA settings
7. Reassemble the sensor into the head housing, replace the front cover and tighten the set screw.
8. Depress and hold the MODE button on the NOVA-Sensor housing and follow the prompts displayed to recalibrate the NOVA-Sensor to the new sensitivity. You will need new calibrating gas of the proper concentration for the new sensitivity. The detector will not read your new target gas correctly if you do not recalibrate using the specified concentration for calibration gas.

Spare Parts & Recommended Test Equipment

The most common spare or replacement parts, available from Safety Systems Technology are listed below. For purchase these parts, contact your local SST distributor, or contact us at sales@safetysys.com.

TROUBLESHOOTING

Check Calibration message

The sensor head has lost some sensitivity, resulting in display values of less than 0 PPM. You must perform a recalibration procedure to correct this. If the recalibration does not result in a 0 PPM reading, the sensor fuel cell has probably been damaged. Replace the fuel cell in the sensor head.

System Fault message

This message may appear when the existing electronics module in the detector is replaced with a different module. Perform a complete recalibration procedure to correct this problem.

The sensor head may have failed. One drop of water inside the sensor may destroy the sensor. The sensor can also be destroyed by exposure to extremely high concentrations of gas for long periods of time. A failed sensor head must have the fuel cell and transmitter replaced, followed by a recalibration of the detector.

The 24 volt DC power supplied to the detector may be less than 16 volts or greater than 32 volts. Replace or service the power supply.

Although not a regular occurrence, it is possible that an internal failure has occurred in the detector electronics module. We suggest you purchase a replacement electronics module, then return the failed electronics module to SST for repairs. The repaired module can then be placed in your stock for future use.

Other Calibration messages

The below listed messages occur during recalibrations. To stop the calibration process at any one of these steps, just push the large mode button on the side of the enclosure two times. The NOVA-Sensor will return to normal operation using the previous calibrations.

HOLD FOR CALIBRATION MODE
RELEASE BUTTON NOW
FINDING ZERO...WAIT
APPLY 50 PPM GAS
GAS DETECTED...WAIT
REMOVE GAS...WAIT
CALIBRATION COMPLETE

Drifting or unstable PPM readings

Check the 2 wires between the sensor head and the electronics module. Screw terminals, crimped connectors or wire nuts on these wires must be tight to maintain the low resistance connections between the head and the electronics.

Also check the jumper on the two "TOX" pins of the electronics module to be sure that the jumper plugs are securely seated on the pins.

False Alarms

If you are having an unreasonable number of alarms, try to verify the gas concentration near the detector using a personal gas monitor. If there is no gas, or very little gas, recalibrate the NOVA-Sensor *ELITE*. If alarms still occur, the sensor head has probably lost sensitivity, and the detector has tried to compensate by increasing the amplifier sensitivity. In that case, the sensor fuel cell should be replaced and a new calibration performed.

Transient Interference or Power Surges

Transient voltage suppressors in the NOVA-Sensor *ELITE* protect the electronics from transients that may be induced into the field wiring during operation. The terminal marked CHASSIS in the NOVA-Sensor is factory connected to the 24VRET terminal to complete the suppression path. In areas where there are severe high energy transients, including those caused by lightning, you may get more effective transient suppression by removing the factory jumper and connecting the CHASSIS terminal to the earth grounding screw in the detector enclosure.

! WARNING: The above change can be made only if the enclosure is firmly connected to earth ground and the voltage measured between the earth ground screw and the 24VRET terminal is not greater than 2.0 volts DC.

WARRANTY INFORMATION



Safety Systems Technology, Inc. warrants its gas detection products to be free of defects in materials or workmanship and will repair or replace without charge any detector that is found to be defective for one year after the date of manufacture. Gas detection elements that are damaged by exposure to continuous background toxic gas are not covered by this warranty. Further, detection elements that have failed due to incorrect hookup or have been subjected to an over current are not covered by this warranty.

For NOVA-Sensor ELITE Gas Detectors - Electronic Components ONLY

- First Two Years - Full Replacement
- Year 3 - SST Covers 75% of Replacement Charge*
- Year 4 - SST Covers 50% of Replacement Charge*
- Year 5 - SST Covers 25% of Replacement Charge*

* Replacement Charge is based on the current list price of the unit at time of claim.

Safety Systems Technology, Inc. (SST) reserves the right to make the final determination of the nature of and responsibility for defective or damaged equipment. Equipment that has been repaired or modified by the user, damaged as the result of an accident, incorrectly installed, or used in an application or environment for which it was not intended is not covered by this warranty. Safety Systems Technology, Inc. (SST) responsibility under this warranty shall be limited to the repair or replacement of the defective equipment at its option when it is returned to the factory transportation prepaid. The defective unit will be repaired or replaced free of charge to the customer and returned transportation prepaid. In all cases, this warranty is limited to the cost of the equipment.

! WARRANTY EXPIRATION DATE: Look for the serial number (SN) visible through the viewing window on the electronics enclosure. The first 2 digits of the serial number are the year of manufacture, the next 2 digits are the week of manufacture. For number SN1242001, the product was manufactured in the 24th week of year 2012 (October 19, 2012). The warranty would expire 5 years from that date (October 18, 2017).

Blank Page