



**SXE-SSE DN 10÷50**

PVC-U

Easyfit True Union ball and spring check valve

# SXE-SSE DN 10÷50

The Easyfit check valve line developed with Giugiaro Design offers two different versions: SXE with ball shutter and SSE with spring loaded shutter. Easyfit check valves stand out for the innovative installation method that guarantees reliable service over time. This valve is also equipped with the customisable Labelling System.



## EASYFIT TRUE UNION BALL AND SPRING CHECK VALVE

- Connection system for solvent weld and threaded joints
- **Valve material compatibility (PVC-U)** with water conveyance, drinking water and other food substances according to current regulations
- **PN16 True Union** valve body made for PVC-U injection moulding and European Directive 2014/68/EU (PED) compliant for pressurised equipment. ISO 9393 compliant test requirements
- Fully interchangeable with VXE and VEE DN 10÷50 ball valve models
- Union nuts with rack for tightening adjustment via Easyfit handle or via Easytorque adjustment kit (available as accessories)
- **Vertical** (preferable for SXE model) and **horizontal installation** potential

Technical specifications	
<b>Construction</b>	<b>SXE:</b> Easyfit True Union ball check valve with locked carrier. <b>SSE:</b> Easyfit True Union spring check valve
<b>Size range</b>	DN 10 ÷ 50
<b>Nominal pressure</b>	PN 16 with water at 20 °C
<b>Temperature range</b>	0 °C ÷ 60 °C
<b>Coupling standards</b>	<b>Solvent welding:</b> EN ISO 1452, EN ISO 15493, BS 4346-1, DIN 8063, NF T54-028, ASTM D 2467, JIS K 6743. Pipe coupling capacity according to EN ISO 1452, EN ISO 15493, DIN 8062, NF T54-016, ASTM D 1785, JIS K 6741. <b>Thread:</b> ISO 228-1, DIN 2999, ASTM D 2464, JIS B 0203.
<b>Reference standards</b>	<b>Criteri Costruttivi:</b> EN ISO 16137, EN ISO 1452, EN ISO 15493 <b>Metodi e requisiti dei test:</b> ISO 9393 <b>Installation criteria:</b> DVS 2204, DVS 2221, UNI 11242
<b>Valve material</b>	PVC-U
<b>Seal material</b>	EPDM, FKM
<b>Spring material (SSE)</b>	Available in STAINLESS steel 316, Hastelloy C276, A316 PTFE encapsulated (DN 32, DN 40 and DN 50 only)

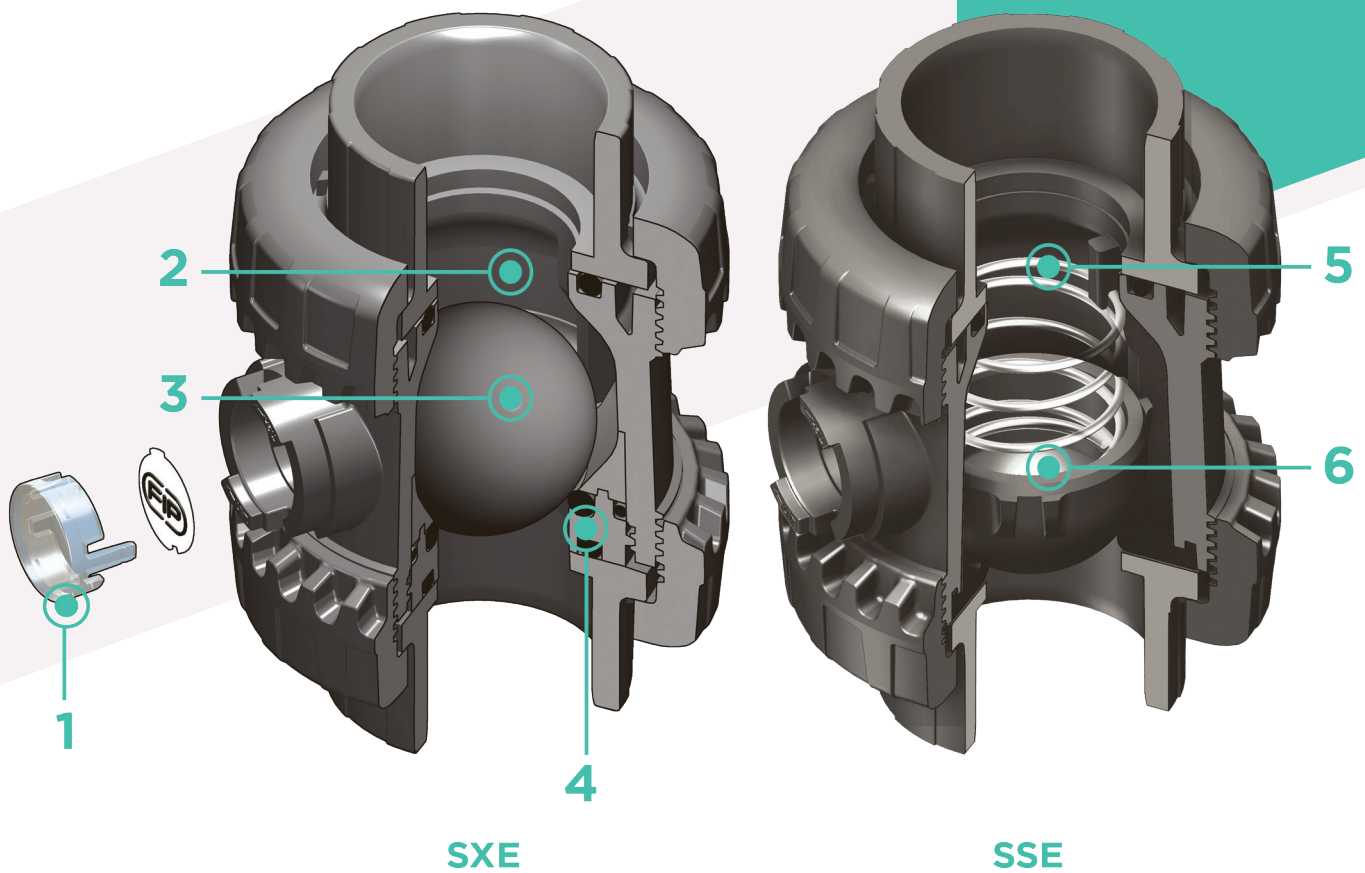

**1 Customisable Labelling System: built-in LCE module** on the valve body made up of transparent protection plug and customisable tag holder using the LSE set (available as accessory). The customisation potential lets you identify the valve on the system according to specific needs.

**2 Optimised dynamic fluid design:** energy savings thanks to the improved valve Kv value with consequent pressure drop reduction

**3 High surface finish ball shutter: wear reduction,** increase in working life and reduced valve maintenance. Ideal for conveying dirty fluids, even with suspended solids and filaments thanks to the special design that permits **internal valve selfcleaning**

**4 Locked ball seat carrier:** safe dismantling for maintenance with the Easyfit multifunctional handle or Easytorque kit

**5 Ideal for horizontal installations: perfect seal even with low back**

**pressure. Silent** and durable even with strong vibrations and pulsating fluid

**6 PVC-U shutter and springs** available made of STAINLESS steel 316, Hastelloy C276, A316 PTFE encapsulated: maximum reliability in a **wide field of applications** from salt water to aggressive acids

# TECHNICAL DATA

## PRESSURE VARIATION ACCORDING TO TEMPERATURE

For water and harmless fluids to which the material is classified as CHEMICALLY RESISTANT. In other cases, a reduction of the nominal PN pressure is required (25 years with safety factor).



## PRESSURE DROP GRAPH

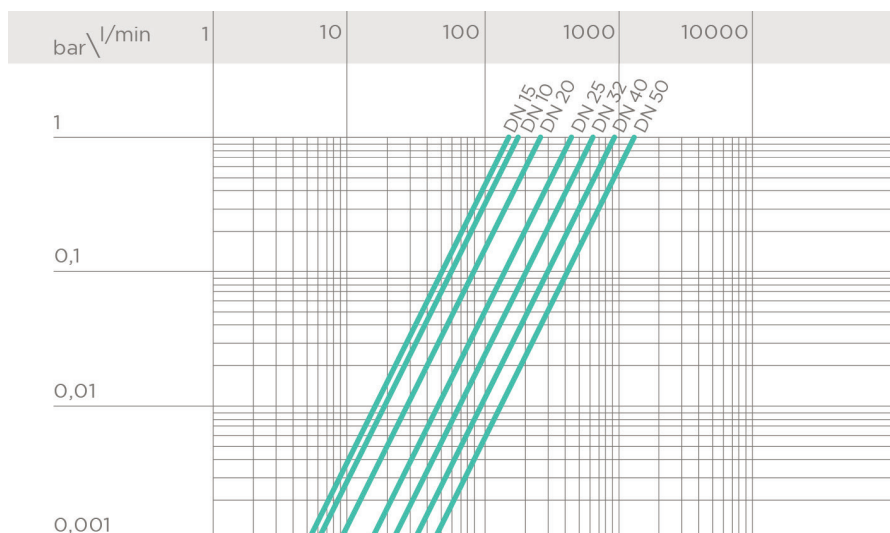

## K<sub>v</sub>100 FLOW COEFFICIENT

The K<sub>v</sub>100 flow coefficient is the Q flow rate of litres per minute of water at a temperature of 20°C that will generate Δp= 1 bar pressure drop at a certain valve position. The Kv100 values shown in the table are calculated with the valve completely open.

DN	10	15	20	25	32	40	50
Kv100 l/min	172	152	258	433	643	928	1343

## MINIMUM VALVE SEALING PRESSURE

The PVC-U SXE valve can only be used with liquids with specific weight under 1.37g/cm<sup>3</sup>.

DN	10	15	20	25	32	40	50
SXE (bar)	0,2	0,2	0,2	0,2	0,2	0,2	0,2
SSE (bar)	0,08	0,08	0,08	0,08	0,08	0,08	0,08

The information in this leaflet is provided in good faith. No liability will be accepted concerning technical data that is not directly covered by recognised international standards. FIP reserves the right to carry out any modification. Products must be installed and maintained by qualified personnel.

# DIMENSIONS

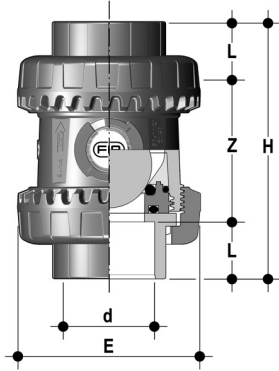

## SXEIV

Easyfit ball check valve with female ends for solvent welding, metric series

d	DN	PN	E	H	L	Z	g	EPDM code	FKM code
16	10	16	54	82	14	54	145	SXEIV016E	SXEIV016F
20	15	16	54	82	16	50	148	SXEIV020E	SXEIV020F
25	20	16	63	91	19	53	190	SXEIV025E	SXEIV025F
32	25	16	72	103	22	59	300	SXEIV032E	SXEIV032F
40	32	16	85	120	26	68	460	SXEIV040E	SXEIV040F
50	40	16	100	139	31	77	675	SXEIV050E	SXEIV050F
63	50	16	118	174	38	98	1080	SXEIV063E	SXEIV063F

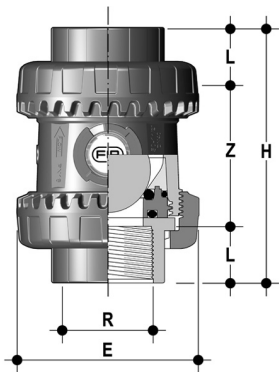

## SXEFV

Easyfit ball check valve with BSP threaded female ends

R	DN	PN	E	H	L	Z	g	EPDM code	FKM code
3/8"	10	16	54	82	11,4	59,2	145	SXEFV038E	SXEFV038F
1/2"	15	16	54	90	15	60	148	SXEFV012E	SXEFV012F
3/4"	20	16	63	93	16,3	60,4	190	SXEFV034E	SXEFV034F
1"	25	16	72	110	19,1	71,8	300	SXEFV100E	SXEFV100F
1" 1/4	32	16	85	127	21,4	84,2	460	SXEFV114E	SXEFV114F
1" 1/2	40	16	100	131	21,4	88,2	675	SXEFV112E	SXEFV112F
2"	50	16	118	161	25,7	109,6	1080	SXEFV200E	SXEFV200F



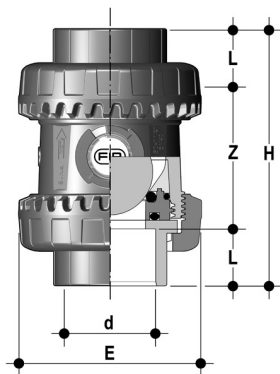

## SXELV

Easyfit ball check valve with female ends for solvent welding, BS series

d	DN	PN	E	H	L	Z	g	EPDM code	FKM code
3/8"	10	16	54	78	14,5	49	153	SXELV038E	SXELV038F
1/2"	15	16	54	82	16,5	49	148	SXELV012E	SXELV012F
3/4"	20	16	63	91	19	53	190	SXELV034E	SXELV034F
1"	25	16	72	103	22,5	58	300	SXELV100E	SXELV100F
1 1/4"	32	16	85	120	26	68	460	SXELV114E	SXELV114F
1 1/2"	40	16	100	139	30	79	675	SXELV112E	SXELV112F
2"	50	16	118	174	36	102	1080	SXELV200E	SXELV200F

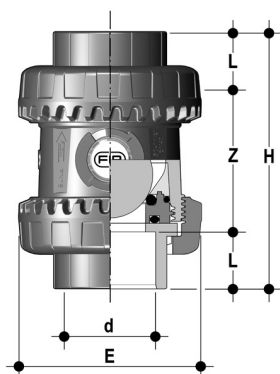

## SXEAV

Easyfit ball check valve with female ends for solvent welding, ASTM series

d	DN	PN	E	H	L	Z	g	EPDM code	FKM code
1/2"	15	16	54	96	22,5	51	148	SXEAV012E	SXEAV012F
3/4"	20	16	63	105	25,5	54	190	SXEAV034E	SXEAV034F
1"	25	16	72	117	28,7	59,5	300	SXEAV100E	SXEAV100F
1 1/4"	32	16	85	136	32	72	460	SXEAV114E	SXEAV114F
1 1/2"	40	16	100	147	35	77	675	SXEAV112E	SXEAV112F
2"	50	16	118	174	38,2	97,6	1080	SXEAV200E	SXEAV200F

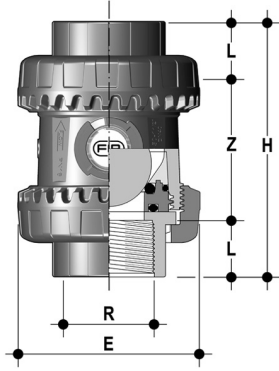

## SXENV

Easyfit ball check valve with female ends, NPT thread

R	DN	PN	E	H	L	Z	g	EPDM code	FKM code
3/8"	10	16	54	82	13,7	54,6	145	SXENV038E	SXENV038F
1/2"	15	16	54	90	17,8	54,4	148	SXENV012E	SXENV012F
3/4"	20	16	63	93	18	57	190	SXENV034E	SXENV034F
1"	25	16	72	110	22,6	64,8	300	SXENV100E	SXENV100F
1"1/4	32	16	85	127	25,1	76,8	460	SXENV114E	SXENV114F
1"1/2	40	16	100	131	24,7	81,6	675	SXENV112E	SXENV112F
2"	50	16	118	161	29,6	101,8	1080	SXENV200E	SXENV200F

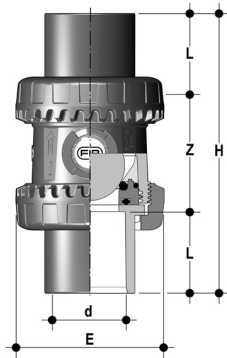

## SXEJV

Easyfit ball check valve with female ends for solvent welding, JIS series

d	DN	PN	E	H	L	Z	g	EPDM code	FKM code
1/2"	15	16	54	110	30	50	160	SXEJV012E	SXEJV012F
3/4"	20	16	63	123	35	53	235	SXEJV034E	SXEJV034F
1"	25	16	72	139	40	59	325	SXEJV100E	SXEJV100F
1"1/4	32	16	85	156	44	68	490	SXEJV114E	SXEJV114F
1"1/2	40	16	100	187	55	77	680	SXEJV112E	SXEJV112F
2"	50	16	118	228	63	102	1150	SXEJV200E	SXEJV200F

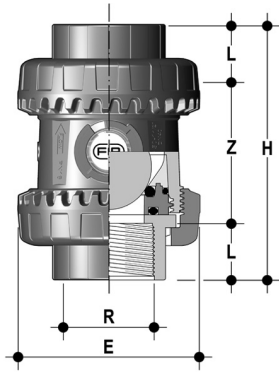

## SXEGV

Easyfit ball check valve with female ends, JIS thread

R	DN	PN	E	H	L	Z	g	EPDM code	FKM code
1/2"	15	16	54	82	16	50	148	SXEGV012E	SXEGV012F
3/4"	20	16	63	91	19	53	190	SXEGV034E	SXEGV034F
1"	25	16	72	103	22	59	300	SXEGV100E	SXEGV100F
1 1/4"	32	16	85	120	25	70	460	SXEGV114E	SXEGV114F
1 1/2"	40	16	100	139	26	87	675	SXEGV112E	SXEGV112F
2"	50	16	118	174	31	112	1080	SXEGV200E	SXEGV200F



## SXEBEV

Easyfit ball check valve with PE100 SDR 11 male ends for butt welding or electrofusion welding (CVDE)

d	DN	E	H	L	Z	g	EPDM code	FKM code
20	15	54	154	40,5	73	150	SXEBEV020E	SXEBEV020F
25	20	63	189	54	81	225	SXEBEV025E	SXEBEV025F
32	25	72	203	56	91	310	SXEBEV032E	SXEBEV032F
40	32	85	221	56	109	485	SXEBEV040E	SXEBEV040F
50	40	100	246	60,5	125	700	SXEBEV050E	SXEBEV050F
63	50	118	276	65,5	145	1150	SXEBEV063E	SXEBEV063F



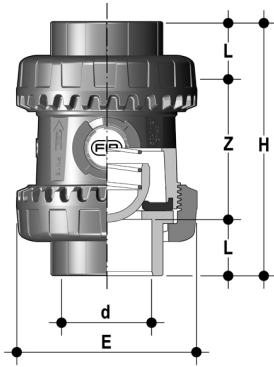

## SSEIV

Easyfit spring check valve with female ends for solvent welding, metric series

d	DN	PN	E	H	L	Z	g	EPDM code	FKM code
16	10	16	54	82	14	54	146	SSEIV016E	SSEIV016F
20	15	16	54	82	16	50	149	SSEIV020E	SSEIV020F
25	20	16	63	91	19	53	188	SSEIV025E	SSEIV025F
32	25	16	72	103	22	59	292	SSEIV032E	SSEIV032F
40	32	16	85	120	26	68	445	SSEIV040E	SSEIV040F
50	40	16	100	139	31	77	640	SSEIV050E	SSEIV050F
63	50	16	118	174	38	98	1010	SSEIV063E	SSEIV063F

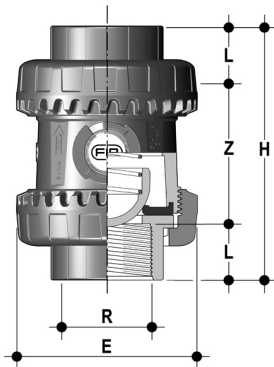

## SSEFV

Easyfit spring check valve with BSP threaded female ends

R	DN	PN	E	H	L	Z	g	EPDM code	FKM code
3/8"	10	16	54	82	11,4	59,2	146	SSEFV038E	SSEFV038F
1/2"	15	16	54	90	15	60	149	SSEFV012E	SSEFV012F
3/4"	20	16	63	93	16,3	60,4	188	SSEFV034E	SSEFV034F
1"	25	16	72	110	19,1	71,8	292	SSEFV100E	SSEFV100F
1" 1/4	32	16	85	127	21,4	84,2	445	SSEFV114E	SSEFV114F
1" 1/2	40	16	100	131	21,4	88,2	640	SSEFV112E	SSEFV112F
2"	50	16	118	161	25,7	109,6	1010	SSEFV200E	SSEFV200F

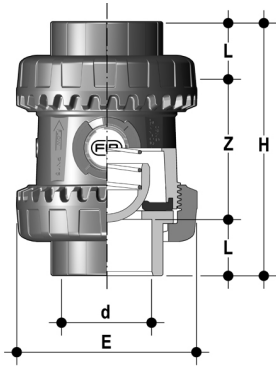

## SSELV

Easyfit spring check valve with female ends for solvent welding, BS series

d	DN	PN	E	H	L	Z	g	EPDM code	FKM code
3/8"	10	16	54	78	14,5	49	154	SSELV038E	SSELV038F
1/2"	15	16	54	82	16,5	49	149	SSELV012E	SSELV012F
3/4"	20	16	63	91	19	53	188	SSELV034E	SSELV034F
1"	25	16	72	103	22,5	58	292	SSELV100E	SSELV100F
1" 1/4	32	16	85	120	26	68	445	SSELV114E	SSELV114F
1" 1/2	40	16	100	139	30	79	640	SSELV112E	SSELV112F
2"	50	16	118	174	36	102	1010	SSELV200E	SSELV200F

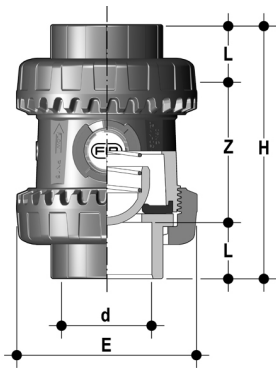

## SSEAV

Easyfit spring check valve with female ends for solvent welding, ASTM series

d	DN	PN	E	H	L	Z	g	EPDM code	FKM code
1/2"	15	16	54	96	22,5	51	149	SSEAV012E	SSEAV012F
3/4"	20	16	63	105	25,5	54	188	SSEAV034E	SSEAV034F
1"	25	16	72	117	28,7	59,5	292	SSEAV100E	SSEAV100F
1" 1/4	32	16	85	136	32	72	445	SSEAV114E	SSEAV114F
1" 1/2	40	16	100	147	35	77	640	SSEAV112E	SSEAV112F
2"	50	16	118	174	38,2	97,6	1010	SSEAV200E	SSEAV200F

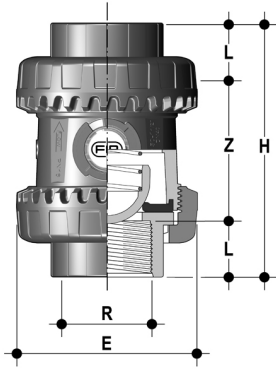

## SSENV

Easyfit spring check valve with female ends, NPT thread

R	DN	PN	E	H	L	Z	g	EPDM code	FKM code
3/8"	10	16	54	82	13,7	54,6	146	SSENV038E	SSENV038F
1/2"	15	16	54	90	17,8	54,4	149	SSENV012E	SSENV012F
3/4"	20	16	63	93	18	57	188	SSENV034E	SSENV034F
1"	25	16	72	110	22,6	64,8	292	SSENV100E	SSENV100F
1" 1/4	32	16	85	127	25,1	76,8	445	SSENV114E	SSENV114F
1" 1/2	40	16	100	131	24,7	81,6	640	SSENV112E	SSENV112F
2"	50	16	118	161	29,6	101,8	1010	SSENV200E	SSENV200F

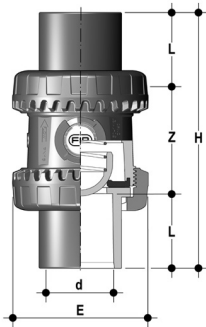

## SSEJV

Easyfit spring check valve with female ends for solvent welding, JIS series

d	DN	PN	E	H	L	Z	g	EPDM code	FKM code
1/2"	15	16	54	110	30	50	161	SSEJV012E	SSEJV012F
3/4"	20	16	63	123	35	53	233	SSEJV034E	SSEJV034F
1"	25	16	72	139	40	59	317	SSEJV100E	SSEJV100F
1" 1/4	32	16	85	156	44	68	475	SSEJV114E	SSEJV114F
1" 1/2	40	16	100	187	55	77	645	SSEJV112E	SSEJV112F
2"	50	16	118	228	63	102	1080	SSEJV200E	SSEJV200F

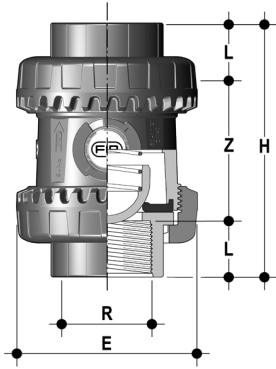

## SSEGV

Easyfit spring check valve with female ends, JIS thread

R	DN	PN	E	H	L	Z	g	EPDM code	FKM code
1/2"	15	16	54	82	16	50	149	SSEGV012E	SSEGV012F
3/4"	20	16	63	91	19	53	188	SSEGV034E	SSEGV034F
1"	25	16	72	103	22	59	292	SSEGV100E	SSEGV100F
1" 1/4	32	16	85	120	25	70	445	SSEGV114E	SSEGV114F
1" 1/2	40	16	100	139	26	87	640	SSEGV112E	SSEGV112F
2"	50	16	118	174	31	112	1010	SSEGV200E	SSEGV200F

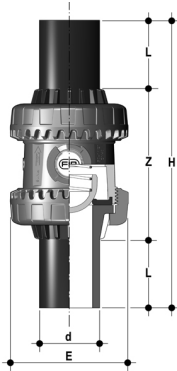

## SSEBEV

Easyfit spring check valve with PE100 SDR 11 male end connectors for butt welding or electrofusion (CVDE)

d	DN	E	H	L	Z	g	EPDM code	FKM code
20	15	54	154	40,5	73	151	SSEBEV020E	SSEBEV020F
25	20	63	186	54	81	223	SSEBEV025E	SSEBEV025F
32	25	72	199	56	91	302	SSEBEV032E	SSEBEV032F
40	32	85	217	56	109	470	SSEBEV040E	SSEBEV040F
50	40	100	236	60,5	125	665	SSEBEV050E	SSEBEV050F
63	50	118	268	65,5	145	1080	SSEBEV063E	SSEBEV063F

# ACCESSORIES

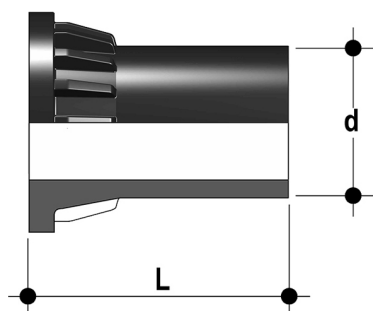

## CVDE

Long spigot PE100 end connectors for joints with electrofusion fittings or for butt welding

d	DN	PN	L	SDR	Code
20	15	16	55	11	CVDE11020
25	20	16	70	11	CVDE11025
32	25	16	74	11	CVDE11032
40	32	16	78	11	CVDE11040
50	40	16	84	11	CVDE11050
63	50	16	91	11	CVDE11063

## Easyfit handle

Easyfit multifunctional handle for union nut tightening SXE-SSE DN 10÷50

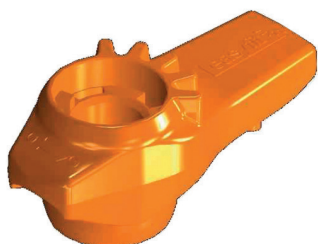

d	DN	Code
16 - 20	10 - 15	HAVXE020
25	20	HAVXE025
32	25	HAVXE032
40	32	HAVXE040
52	40	HAVXE050
63	50	HAVXE063

## EASYTORQUE KIT

Kit for union nut tightening adjustment and ball seat carrier for Easyfit DN 10÷50 valves.



d	DN	Union nut tightening torque*	Seat carrier tightening torque*	Code
3/8"-1/2"	10-15	5 N m - 3,69 Lbf ft	3 N m - 2,21 Lbf ft	KET01
3/4"	20	5 N m - 3,69 Lbf ft	3 N m - 2,21 Lbf ft	KET01
1"	25	6 N m - 4,43 Lbf ft	4 N m - 2,95 Lbf ft	KET01
1" 1/4	32	7 N m - 5,16 Lbf ft	4 N m - 2,95 Lbf ft	KET01
1" 1/2	40	8 N m - 5,90 Lbf ft	5 N m - 3,69 Lbf ft	KET01
2"	50	10 N m - 7,38 Lbf ft	6 N m - 4,43 Lbf ft	KET01

\*calculated in ideal installation conditions



## LSE

Customisation and label printing set for Easyfit handle made up of pre-cut adhesive sheets and software for guided label creation.

d	DN	total labels	N° of sheets	SXE-SSE code
16	10	500	10	-
20	15	500	10	-
25	20	500	10	-
32	25	500	10	LSE020
40	32	500	10	LSE025
50	40	500	10	LSE032
63	50	500	10	LSE032

# CUSTOMISATION

Fig. 1



Fig. 2

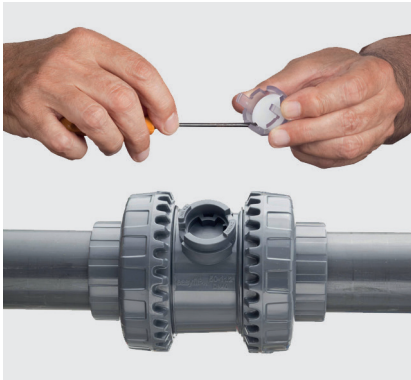

Fig. 3



SXE and SSE DN 10÷50 Easyfit valves are equipped with a customisable Labelling System.

This system lets you create special labels to affix to the valve body. This makes it extremely easy to apply company logos, identification serial numbers or service indications such as, for example, the valve function in the system, the transported fluid, but also specific information for customer service, such as the customer name or installation date or location on the valves.

The specific LCE module is a standard supply and is made up of a rigid transparent water-resistant PVC plug and white tag holder made of the same material, one side of which bears the FIP logo (fig. 1).

The holder, inserted in the plug, can be removed and, once overturned, used for customisation by applying labels printed with the software supplied with the LSE set.

Proceed as follows to apply the label on the valve:

- 1) Extract the transparent plug from the seat on the valve body (fig. 1).
- 2) Extract the tag holder from the transparent plug (fig. 2).
- 3) Apply the adhesive label on the tag holder to align the profiles matching the tab position.
- 4) Re-insert the tag holder in the transparent plug so that the label is protected from the elements.
- 5) Replace the transparent plug in its seat on the valve body.



# COMPONENTS

## EXPLODED VIEW

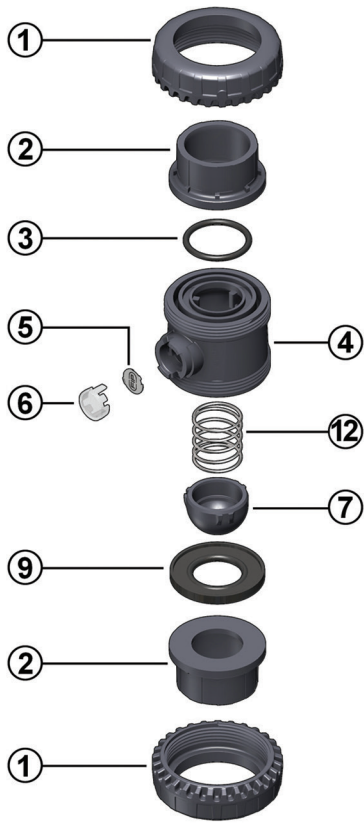

**SSE**

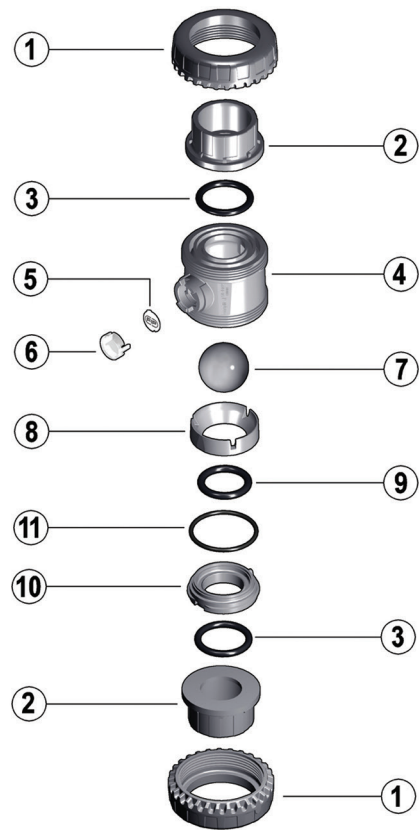

**SXE**

- |          |                                       |              |                                  |           |                                   |
|----------|---------------------------------------|--------------|----------------------------------|-----------|-----------------------------------|
| <b>1</b> | Union nut (PVC-U - 2)                 | <b>7 SXE</b> | Ball (PVC-U - 1)                 | <b>11</b> | Radial seal O-Ring (EPDM,FKM - 1) |
| <b>2</b> | End connector (PVC-U - 2)             | <b>7 SSE</b> | Shutter (PVC-U - 1)              | <b>12</b> | Spring (STAINLESS steel* - 1)     |
| <b>3</b> | Socket seal O-Ring (EPDM, FKM - 2)    | <b>8</b>     | Gland packing ring (PVC-U - 1)   |           |                                   |
| <b>4</b> | Body (PVC-U - 1)                      | <b>9 SXE</b> | Ball seat O-Ring (EPDM, FKM - 1) |           |                                   |
| <b>5</b> | Tag holder (PVC - 1)                  | <b>9 SSE</b> | Shutter gasket (EPDM, FKM - 1)   |           |                                   |
| <b>6</b> | Transparent protection plug (PVC - 1) | <b>10</b>    | Ball seat carrier (PVC-U - 1)    |           |                                   |

\* Also available made of Hastelloy C276 or A316 PTFE encapsulated (for DN 40 and DN 50 only)  
The component material and quantity supplied are indicated in the parentheses.

## DISASSEMBLY

### SXE

SXE valves do not require maintenance in normal operating conditions. In the event of leaks or wear, before performing maintenance, cut-off fluid upstream from the valve and make sure it is de-pressurised (downstream drain if necessary).

- 1) Fully drain residual liquid that could be aggressive for the operator and, if possible, circulate water to internally clean the valve.
- 2) To easily unscrew the union nuts when dismantling, use the Easyfit multifunctional handle (supplied as an accessory) (fig. 4) or Easytorque kit (fig. 5-6).
- 3) Unscrew the seal carrier (10) with the Easyfit multifunctional handle (fig. 7) or Easytorque kit (fig. 8).
- 4) Remove all internal components.

### SSE

In the event of leaks or wear, before performing maintenance, cut-off fluid upstream from the valve and make sure it is de-pressurised (downstream drain if necessary).

- 1) Fully drain residual liquid that could be aggressive for the operator and, if possible, circulate water to internally clean the valve.
- 2) To easily unscrew the union nuts when dismantling, use the Easyfit multifunctional handle (supplied as an accessory) (fig. 4) or Easytorque kit (fig. 5-6).
- 3) Extract the ball seat O-ring (9).
- 4) Remove all internal components.

## ASSEMBLY

### SXE

- 1) Reconstruct the valve following the exploded view on the previous page
- 2) Tighten the ball seat carrier (10) using the Easyfit multifunctional handle (fig. 7) or Easytorque wrench (fig. 8) according to the torque indicated in the enclosed instructions. This way valve installation and excellent operations are guaranteed
- 3) Position the valve between the end connectors (2) and tighten the union nuts clockwise (1) using the Easyfit multifunctional handle (fig. 4) or Easytorque kit (fig. 5-6), being sure the socket seal O-ring (3) does not exit the seats.

### SSE

- 1) Reconstruct the valve following the exploded view on the previous page.
- 2) Position the valve between the end connectors (2) and tighten the union nuts clockwise (1) using the Easyfit multifunctional handle (fig. 4) or Easytorque kit (fig. 5-6), being sure the socket seal O-ring (3) does not exit the seats.



**Note:** during assembly operations, it is advisable to lubricate the rubber seals. Mineral oils are not recommended for this task as they react aggressively with EPDM rubber.

Fig. 4

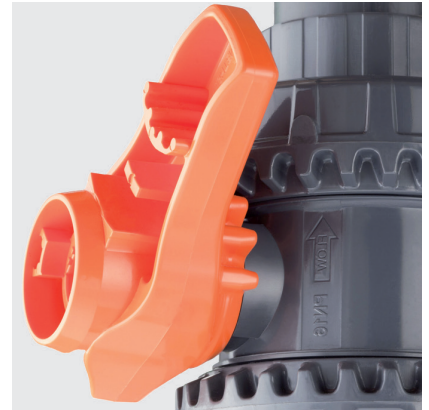

Fig. 5



Fig. 6



Fig. 7



# INSTALLATION

SXE-SSE valves can be installed both vertically (upward flow) or horizontally (SXE with a minimum 0.2 bar back pressure). Before proceeding with installation, please follow these instructions carefully:

- 1) Check that the pipes to be connected to the valve are aligned in order to avoid mechanical stress on the threaded joints.
- 2) Unscrew the union nuts (1) from the body (4) and insert them in the pipe segments.
- 3) Solvent weld or screw the end connectors (2) onto the pipe segments.
- 4) Position the valve body between the end connectors (fig. 9).
- 5) Fit the union nuts on the valve body and manually tighten clockwise until they become hard to turn; do not use wrenches or other tools that can damage the union nut surfaces.
- 6) For easy union nut tightening in assembly, use the Easyfit multifunctional handle (supplied as an accessory).
- 7) Overturn the handle and insert it on the stem so the handle teeth (A) match the union nut teeth (B) (fig. 10)
- 8) Turn the handle counter-clockwise to fully tighten the union nut (fig. 10). The rotation directions to tighten (TIGHTEN) and loosen (UNTIGHTEN) the union nuts are indicated on the handle (fig. 11). Generally, if pipes are not offset, a single turn is sufficient for correct tightening.
- 9) Repeat point 7 for the other union nut. Note: A small force applied on the handle develops a torque much higher than manual tightening. You can also, using the Easytorque kit (fig. 5-6), supplied as an accessory, tighten union nuts using a torque wrench to quantify the force and thus monitor the stress applied to the thermoplastic threads according to the installation indications in the instructions enclosed with the kit.
- 10) If necessary, support pipes with FIP pipe clip model ZIKM and DSM distance plates.

## WARNINGS

Do not use compressed air or other gases to test thermoplastic lines. Always avoid sudden closing manoeuvres and protect the valve against accidental manoeuvres. Leave a straight section of pipe of length equal to 5 times the nominal diameter before and after the valve.

Fig. 8



Fig. 9



Fig. 10



Fig. 11

