

PROPORTIONAL 4-WAY CONTROL VALVES SOLENOID OPERATED IN STAINLESS STEEL HD3-AMPS 32 l/min 35 MPa (350 bar)

1 DESCRIPTION

Valves HD3-AMPS are proportional directional control valve with subplate mounting interface according to ISO 4401, DIN 24340 (CETOP 03).

The body has a five chamber design, manufactured by Additive Manufacturing technology with stainless steel AISI 316L for high performance and low pressure drops. Tubes are also made with stainless steel. The valve is available with several spools in order to control different flow ranges.

2 ORDERING CODE

(1)	(2)	(3)	(4)	(5)	(6)	(7)
HD3	-	PS	-		-	10

(1) 4-way directional valve CETOP 03 – Pressure 32 MPa (320 bar)

(2) PS : Proportional electric control

(3) Functional spool type (see 4):

-number is the main spool type

1: closed center (P, A, B, T blocked)

3: P blocked, A, B, T connected

(4) spool nominal flow

P : 32 l/min with $\Delta P = 1$ MPa (10 bar) (PA+BT or PB+AT)

R : 16 l/min with $\Delta P = 1$ MPa (10 bar) (PA+BT or PB+AT)

05 : 05 l/min with $\Delta P = 1$ MPa (10 bar) (PA+BT or PB+AT)

D : differential $Q_b = 2Q_a$: 32/16 l/min with $\Delta P = 1$ MPa (10 bar)

(5) letter is the solenoid or spring arrangement:

C : 2 solenoids, spool is springs centred

ML : 1 solenoid ("a") spool is centred + 1 end position

MLb : 1 solenoid ("b") spool is centred + 1 end position

(6) Type of coil and supply voltages

R2 : R= 4,35 Ω standard for V12DC

R4 : R=11,4 Ω standard for V24DC

(7) Design number (progressive) of the valve.

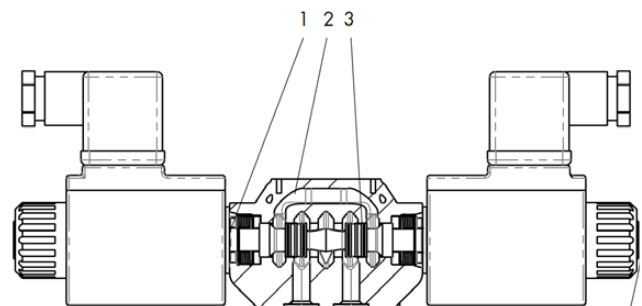
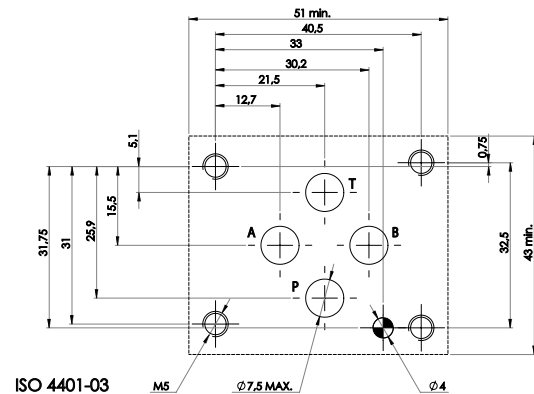
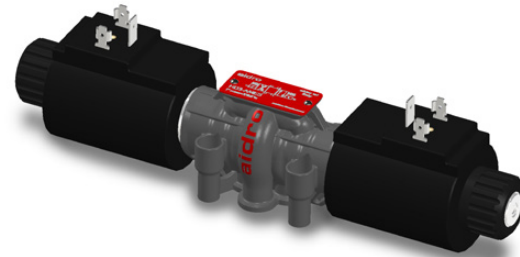

3 TYPICAL DIAGRAMS

Typical flow curves of valves HD3-AMPS, with spools type P, R, 05, in standard configuration measured with mineral oil at 36 cSt and at 50°C at $\Delta P=01$ MPa (10 bar) for flow P->B A -> T

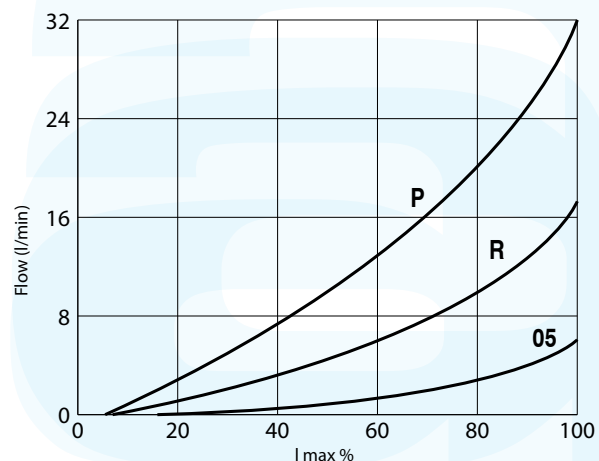

The spool 3 shifts in to the valve body 2 subject to the action of springs and proportional solenoid 1. Spool 3, depending from its shape and its position in the valves body 2, opens and/or closes passages between P, A, B, T ports, thus controlling the direction and the rate of the hydraulic flow. Solenoid 1 is energized by electric current flowing-in through cables; in case of electric cut-offs, the spool can be manually shifted by acting on the emergency pins, located at the end of the solenoids and accessible through the retaining nuts.

4 TECHNICAL DATA

Nominal flow rates	5, 16, 32 l/min	Electric Characteristics:
Maximum nominal pressure (P,A,B)	35 MPa (350 bar)	
Maximum pressure at T port	21 MPa (2100 bar)	Valves type HD3-AMPS are operated by proportional solenoids that are rated for an average max power of 13,5 w. The values of nominal max. current are: for coils type R2 (4,35 Ω): I max = 2,4 A R4 (11,4 Ω): I max = 1,0 A
Maximum rec. Pressure drops	10 MPa (100 bar)	
Protection DIN 40050	IP 65 (IP 69)	Currents to hydraulic proportional valves are normally supplied by an electronic driver based on PWM mode of operation, capable of full control of min and max values of current for drivers type UED.*
Duty cycle	100%	
Service life	≥ 10 ⁷ cycles	
Installation and Dimensions	(see 6)	
Mass	Approx 1,6 / 2,1 kg.	

5 SPOOL IDENTIFICATION AND NOMINAL FLOW RATE

Nominal Flow rate 5 l/min			
	HD3-AMPS-105ML-R		HD3-AMPS-305ML-R*
	HD3-AMPS-105MLb-R*		HD3-AMPS-305MLb-R*
	HD3-AMPS-105C-R*		HD3-AMPS-305C-R*
Nominal Flow rate 16 l/min			
	HD3-AMPS-1RML-R*		HD3-AMPS-3RML-R*
	HD3-AMPS-1RMLb-R*		HD3-AMPS-3RMLb-R*
	HD3-AMPS-1RC-R*		HD3-AMPS-3RC-R*
Nominal Flow rate 32 l/min			
	HD3-AMPS-1PML-R*		HD3-AMPS-3PML-R*
	HD3-AMPS-1PMLb-R*		HD3-AMPS-3PMLb-R*
	HD3-AMPS-1PC-R*		HD3-AMPS-3PC-R*
Differential flow: Q _b =2Q _a (example P→B=32 l/min and A→T= 16 l/min)			
	HD3-AMPS-1DC-R*		HD3-AMPS-3DC-R*

6 INSTALLATION DIMENSIONS (mm)

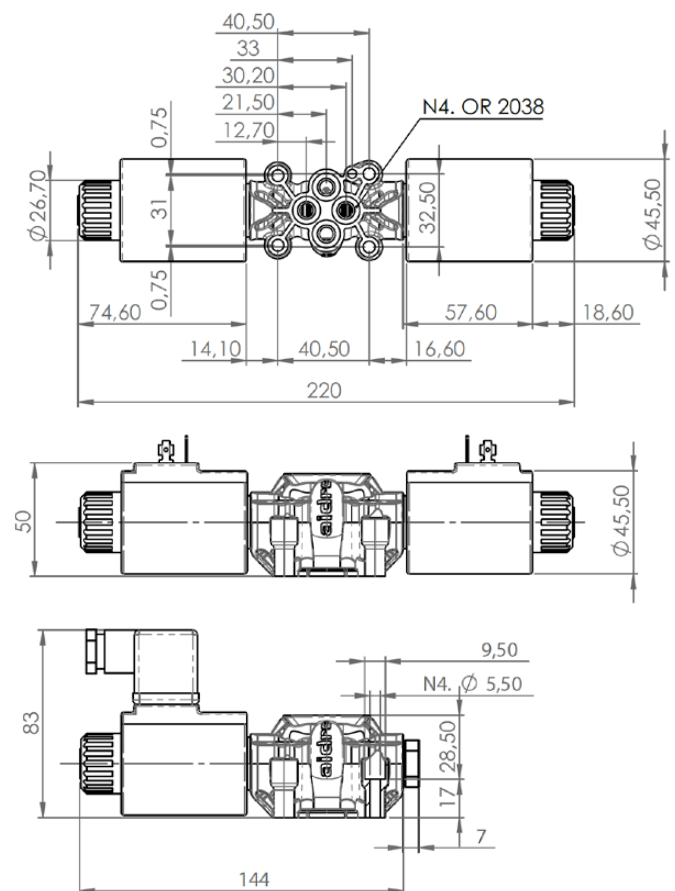

7 FLOW RATES AND PRESSURE DIFFERENTIAL

For a given ΔP on a given valve the flow rates are proportional to the driving current; for a given driving current on a given valve, the flow rates increase with the increasing of the ΔP up to certain limits. Typical limit curves are:

