

Universal Controller for Intermittent Lubrication SIS/U-1.10

Device Description GB 24.05-88
Edition 2.13

Contents

1. Application	1
2. Configuration	1
3. Operation	2
4. Operating Mode J1 for Central Lubrication Systems with Progressive Distributor	3
5. Operating Mode J2 for Central Lubrication Systems with Piston Distributor	5
6. Operating Mode J3 for Discharge Lubrication Systems with Piston Distributor	7
7. Operating Mode J4 for Lubrication Systems with Single Lubrication Point Monitoring	9
8. Operating Mode J5 for Lubrication Systems with Permanent Lubrication	10
9. Error Index	11
10. Pin Assignment	11
11. Dimensions	12
12. Technical Data	12
13. Accessories	13



1. Application

The SIS/U-1.10 Universal Controller for Intermittent Lubrications can be used anywhere, where a lubricant flow or single lubrication points have to be monitored. Missing lubricants can lead to the outage of machines or whole production lines.

The device is suitable for the employment in intermittently operated central lubrication systems with progressive distributors, in central lubrication systems with piston distributors, for single lubrication point monitoring or for the monitoring of the lubricant flow in permanent lubrication systems.

This device can be programmed for different modes of operation and can replace the following older devices:

SISU	Ref. No. 24.05-82
SISP	Ref. No. 24.05-81
SISTP	Ref. No. 24.05-56
SISIP	Ref. No. 24.05-57
SISTU	Ref. No. 24.05-43
SISIU	Ref. No. 24.05-44
SIS-13.43	Ref. No. 24.05-42
ESU	Ref. No. 24.01-32
ESU	Ref. No. 24.01-22
SUL	Ref. No. 24.07-06

2. Configuration

Due to its small size the housing for DIN top hat rails can be easily installed in any control cabinet.

The eight control keys permit simple and fast parameterisation and the 7-segment display indicates the current status. The keys can be locked, and a password used to protect the device against unintentional and unauthorised use. The controller has two switch relays in the control circuit for increased high safety.

The device operating voltage is 24 VDC. For other voltages, the NGS power supply may be used (see chapter 13, accessories).

3. Operation

3.1 General

When the device is switched on for the first time it indicates "ProG". After the parameterisation it indicates "Run" and is immediately in the operating mode after system recovery. If the parameterisation has not been completed, the device will indicate "ProG" which means that no controlling or monitoring takes place.

3.2 Key Locking

By pressing and holding the "Mode of Operation"-key for a while, the keys can be locked against unintentional misadjustment. In this case the word "Lock" appears in the display. Only if the "Mode of Operation"-key is pressed again for some seconds, the keys will again be released.

3.3 Password Entry

After switching on the power supply and pressing the key "0" the password has to be entered. The factory-made password is "100". By pressing the keys "4" and "5" the password can be changed. By pressing and holding these keys, the code runs automatically up and/or down. By pressing the SET key, the correct password is confirmed. The display switches to "ProG" if the device has not been parameterised. If the device has been parameterised, the display will switch to "32767". If the password code is wrong, the display will change to "1".

3.4 Parameterisation



Important information:

Only if the parameterisation process has been completed, the device will be ready for operation.

If the parameterisation process has not been completed correctly, the device will not be ready for operation. The parameterisation mode is left with key "1". If no key is pressed for one minute, the parameterisation mode will be set back and the device will wait for a new password entry.

After entering the password, the key "2" has to be pressed in order to get into the parameterisation mode.

The parameters are selected with the keys "2" and "3". The values of the parameters can be changed with the keys "4" and "5".

The device can be operated in 5 different operating modes, which can be selected according to the individual requirements. The user can select among the operating modes J1 to J5 only one. With the selection the others will be deselected. If e.g. the operating mode J2 is selected, the word "SEL" will appear in the second line of the display. The word "OFF" appears under J1, J3, J4, and J5 since they have not been selected.

By pressing key "5" the operating mode is selected. The meaning of the parameters changes with the respective mode of operation and can be taken from the corresponding lists. The parameterisation is completed by pressing key "1". If no key is pressed for one minute, the device will leave the parameterisation mode. By entering the password code again, the device switches back to the parameterisation mode.

3.5 Changing of the Password Code

After parameterisation and switching on the power supply, the device answers by indicating "Run". By pressing key "0" and entering the correct password code, the controller will answer by indicating "32767". Then, a new password code can be entered. By pressing and holding key "1/2/Set" and actuating key "0", the new password will be accepted.

3.6 Repetition of the Parameterisation



Attention!

The controller is inactive during the parameterisation. If the parameterisation is not completed, the device will not be ready for operation. The parameterisation mode is left with key "1".

If the key "0" is pressed and the right password code is entered, the controller answers by indicating "32767". By pressing key "2" the device changes into the parameterisation mode.

3.7 Error Messages

Errors are indicated with "Error" and the error number. The error index gives information about the type of error. In general K2 serves for the error message. In case of an error K2 drops out (exception is operating mode J5).

4. Operating Mode J1

4.1 Task

Controlling and monitoring of intermittently operated central lubrication facilities with progressive distributors.

When this operating mode is selected, the function of the controller corresponds to the function of the following devices:

SISU/c11a1-1.62	Ref. No. 24.05-82
SISTU	Ref. No. 24.05-43
SISIU	Ref. No. 24.05-44

4.2 Function

With the switching on of the supply voltage the device starts with a lubrication cycle or an interruption cycle depending on parameter P1. The relay K2 pulls in and remains in that condition as long as no error occurs.

In the lubrication cycle a lubrication pump is switched on via K1 or K1a and the progressive distributor starts operation. The cycle switch which is connected to input 2 monitors the piston movement. The cycle switch has to deliver switching edges within the operating time Z.

The operating time is indicated in parameter P3.

The number of switching edges is indicated in parameter P4. The number Z indicated here should not be less 3, since otherwise it cannot be guaranteed that the progressive distributor executes a complete cycle. After Z cycles the relays K1 and K1a drop out and the interruption cycle starts.

If the number 1 was entered in parameter P5, the lubrication interruption time, which was entered in parameter P2, will begin.

If the number 0 was entered in parameter P5, the interruption is load-dependent. This means that the lubrication cycle is started again if the number of strokes given in parameter P2 is reached via the stroke number switch connected to E1.

The interruption time for the set-up mode can be stopped via a contact connected to E5 or the stroke number switch can be suppressed. For monitoring the lubrication reserve a level switch can be connected to E3. This switch can be parameterised with P9 as NC or NO contact (the NO contact closes in case of lack of lubricant).

An error signal remains as long as the power supply has shortly been switched off and on, the "OPERATING MODE"-key "5" was pressed or a reset pulse was transmitted to E7. The reset pulse should at least remain for 10 milliseconds. Intermittent lubrication with E7.

4.3 Error (relays K1, K1a and K2 drop out) if:

- The cycle switch does not transmit any Z signal edges within the operating time.
- The cycle switch emits more than 9 edges within the lubrication interruption time.
- The lubrication switch in the lubricant box reports a lack of lubricant.

An error signal remains stored and can either be deleted by interrupting the power supply or by a high signal at the input E7.

Operating Mode J1		SISU/c11a1-1.62, SISTU, SISIU
P1	If P1 = 1 the device starts with a lubricant cycle	0-1
P2	Interruption time in minutes or machine stroke number in dependence of P5	1-9999
P3	Operating time in seconds	1-9999
P4	Cycle number of the progressive distributor	1-9
P5	Interruption time on = 1; (time-dependent) Interruption time off = 0; (load-operation)	
P6	Not in use	
P7	Not in use	
P8	Activate level switch 1 = On	0-1
P9	If 1 = NO for level switch If 0 = NC for level switch	
P10	Not in use	
Input Wiring		
E1	Machine stroke number switch	
E2	Cycle switch at the progressive distributor	
E3	Level switch	
E5	Stop interruption time	
E7	Reset / intermittent lubrication	
Outputs		
K1	Pump	
K1a	Pump 1	
K2	Error	
Y1	Not in use	

4.4 Flow Chart Operating Mode J1

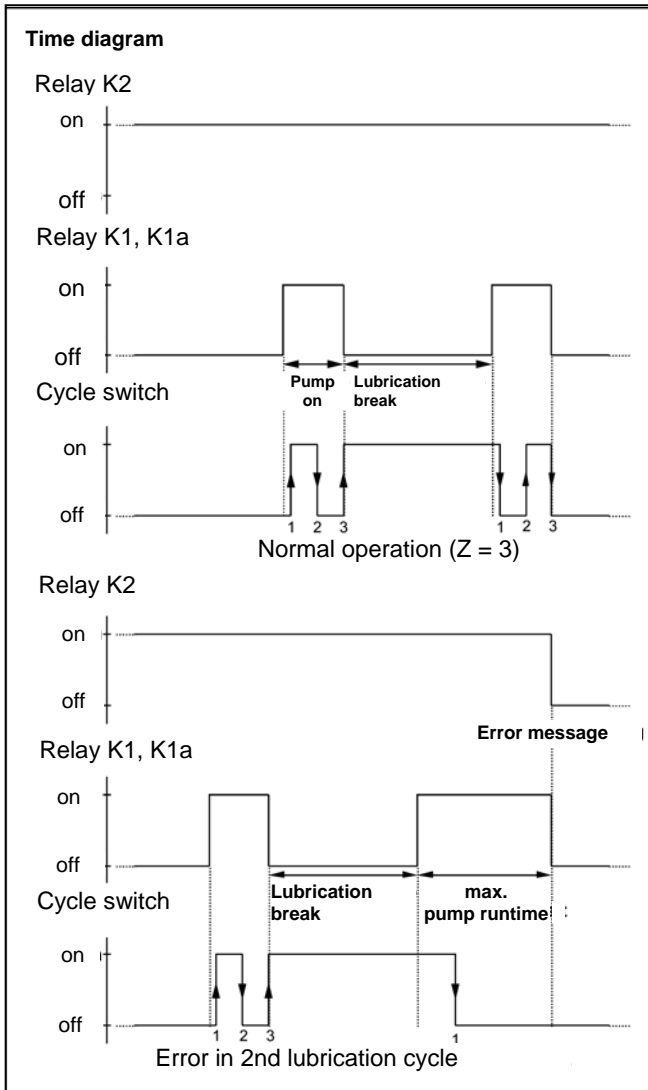

4.5 Wiring

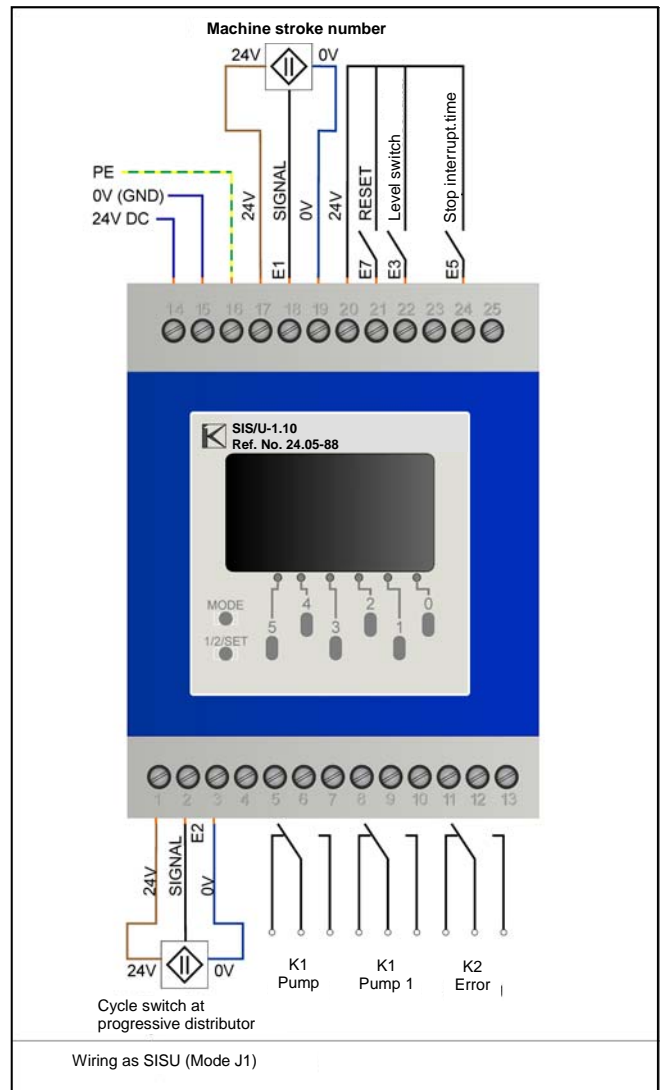

5. Operating Mode J2

5.1 Task

Controlling and monitoring of intermittently operated central lubrication systems with piston distributor.

With the selection of this mode the function of the controller corresponds to the function of the following devices:

SISP	Ref. No. 24.05-81
SISTP	Ref. No. 24.05-56
SISIP	Ref. No. 24.05-57

5.2 Function

With the switching on of the supply voltage the device starts with a lubrication cycle or a break cycle depending on parameter P1. The relay K2 pulls in and remains in that condition as long as no error occurs.

In the lubrication cycle the relays K1 and K1a pull in. Within the pressure build-up time the maximum pressure switch connected to E2 must close. Immediately after closing of the maximum pressure switch the stop-delay time P3 starts. If the pump is to be controlled pressure-dependent only, the stop-delay time shall be reduced to a minimum. As soon as the maximum pressure is reached, the pump engine is switched-off.

If the pump is to be operated time-controlled only, P4 has to be set to "9". The pressure switches may then not be connected.

With expiration of the lubrication cycle the idle cycle begins. The parameter P5 indicates whether the break is load- or time-dependent. For the load-dependent control a stroke rate switch must be connected to E1. Via a contact connected to E5 the interruption time may be stopped for set-up run or the stroke number switch may be suppressed.

For monitoring the lubrication reserve a level switch can be connected to E3. This switch can be parameterised by P9 as NC- or NO contact (the NO contact closes in case of lack of lubricant).

An error signal remains as long as the power supply was shortly switched-off and -on, the "OPERATING MODE"-key "5" was pressed or a reset pulse was transmitted to E7. The reset pulse should at least remain for 10 milliseconds. Intermittent lubrication with E7.

5.3 Error (relays K1, K1a and K2 drop out) if:

- The lubrication switch in the lubricant case reports a lack of lubricant.
- After expiration of the interruption time the minimum- and maximum pressures do not fall below.
- Within the pressure build-up time the minimum- and maximum pressures are not exceeded.
- During the stop-delay time the minimum- and maximum pressures do not fall below.

An error signal remains stored and can either be deleted by interrupting the power supply or by a high signal at the input E7.

Operating Mode J2		SISP/b11a1-1.62, SISTP, SISIP
P1	If P1 = 1 the device starts with a lubricant cycle	0-1
P2	Interruption time in minutes or machine stroke number in dependence of P5	1-9999
P3	Operating time in deci-seconds	1-9999
P4	9 = operation without pressure switch	
P5	Interruption time on = 1; (time-dependent) Interruption time off = 0; (load-operation)	
P6	Pressure build-up time in seconds	1-1000
P7	Use min. pressure switch	
P8	Activate level switch 1 = On	0-1
P9	1 = NO for level switch 0 = NC for level switch	
P10	Not in use	
Input Wiring		
E1	Machine stroke number switch	
E2	Max. pressure switch	
E3	Min. pressure switch	
E4	Level switch	
E5	Stop interruption time	
E7	Reset / intermittent lubrication	
Outputs		
K1	Pump	
K1a	Pump 1	
K2	Error	
Y1	Not in use	

5.4 Flow Chart Operating Mode J2

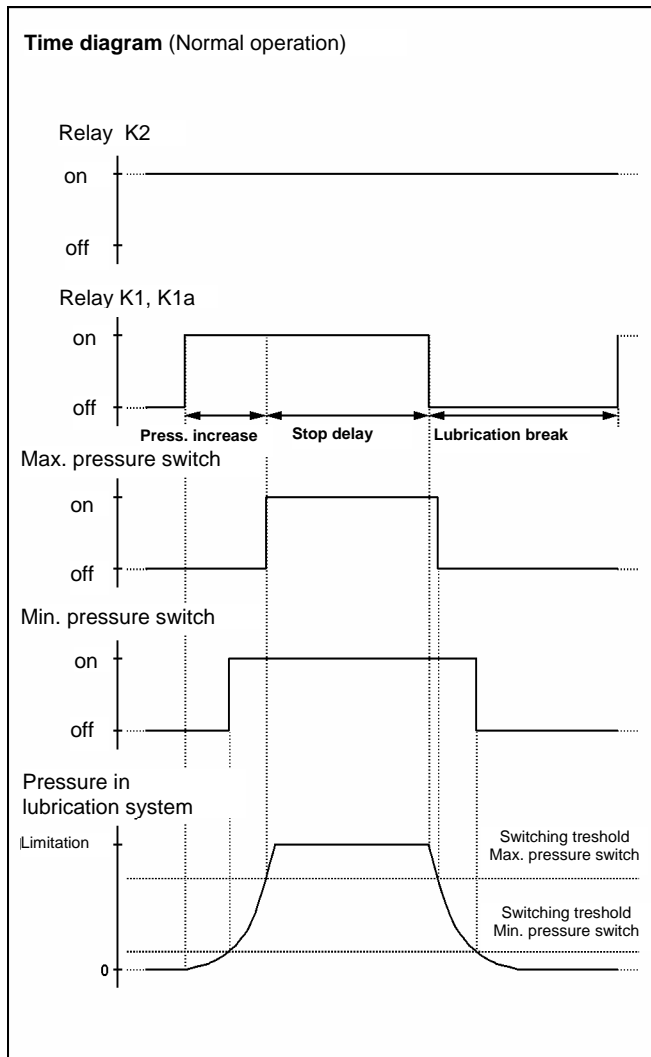

5.5 Wiring

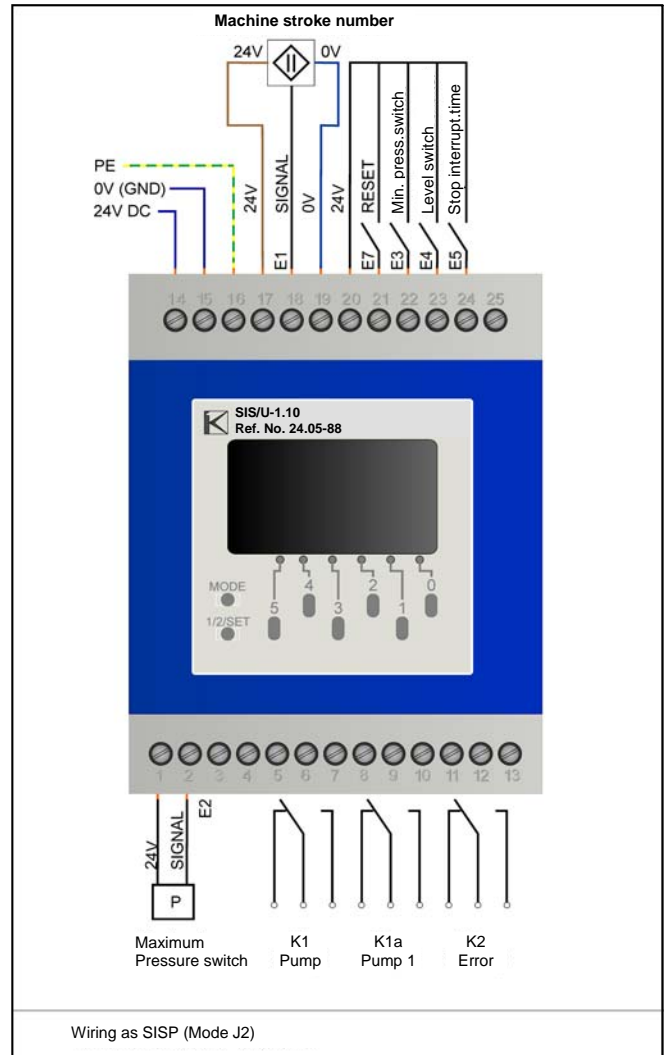

6. Operating Mode J3

6.1 Task

Controlling and monitoring of intermittently operated discharging- and central lubrication systems with piston distributor.

With the selection of this mode the function of the controller corresponds to the function of the following device:

SISP Ref. No. 24.05-42

6.2 Function

With the switching on of the supply voltage the device always starts with a lubrication cycle. The duration of the lubrication process can be controlled pressure-, time- or pressure- and time-dependent.

With a pressure-dependent controller the stop-delay time is set to a minimum, whereby the lubrication stops as soon as the nominal pressure in the lubrication system is reached.

With pure time control (operation without pressure switches) the lubrication duration is determined by the pressure build-up time P6 and the stop-delay time P3.

If a pressure- and time-dependent control takes place, first the pressure build-up time runs until reaching the nominal pressure. Then the stop-delay time follows. Each lubrication cycle is followed by an interruption cycle which can be load- or time-sensitive depending on the setting of parameter P5.

With a load-dependent interruption cycle the machine has to be connected to two stroke number switches, which close alternately. The two switching signals shall not overlap each other. In case of an error K2 (command circle), K1 as well as K1a (control circuit) drop out.

An error signal is indicated as long as the power supply has been shortly switched-on and -off, the "OPERATING MODE"-key "5" has been pressed or a reset pulse has been transmitted to E7. The reset pulse should at least remain for 10 milliseconds.

6.3 Error (Relays K1, K1a und K2 drop out) if:

- No pressure build-up takes place within the pressure build-up time and P7 on 1 = On.
- After termination of the interruption cycle the pressure switch has not dropped out (P7 on 1).
- The stroke rate switch signals overlap each other.
- After termination of the interruption cycle the counters of the stroke rate switches do not indicate the same status.
- A switch closes more than 3 times, without that the other one has been activated.

Operating Mode J3		SIS-13.43
P1	Not in use	
P2	Interruption time in minutes or machine-stroke rate in dependence of P5	1-9999
P3	Operating time in seconds	1-9999
P4	Not in use	
P5	Interruption time on = 1; (time-dependent) Interruption time off = 0; (load-operation)	
P6	Pressure build-up time in seconds	1-1000
P7	Use pressure switch 1 = On	
P8	Not in use	
P9	Not in use	
P10	Not in use	

Input Wiring	
E1	Machine stroke number switch 1
E2	Machine stroke number switch 2
E3	Max. pressure switch
E7	Reset
Outputs	
K1	Pump
K1a	Pump 1
K2	Error
Y1	Not in use

6.4 Flow Chart Operating Mode J3

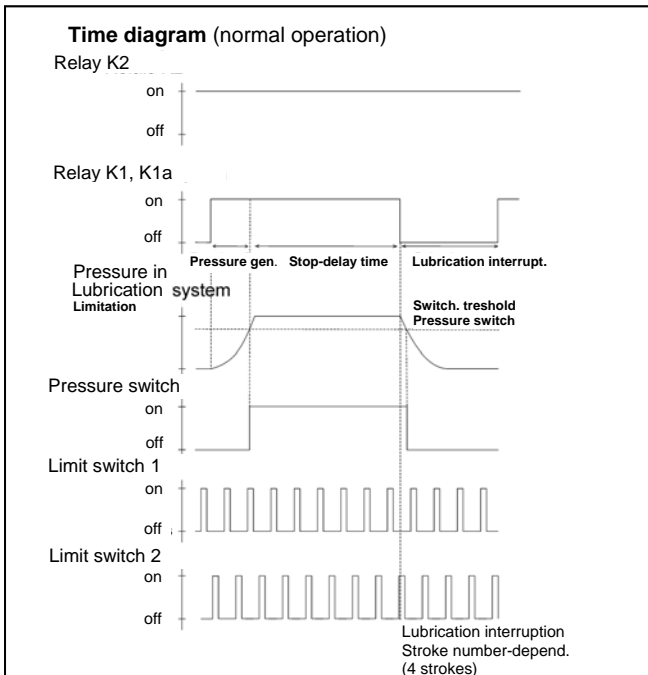

6.5 Wiring

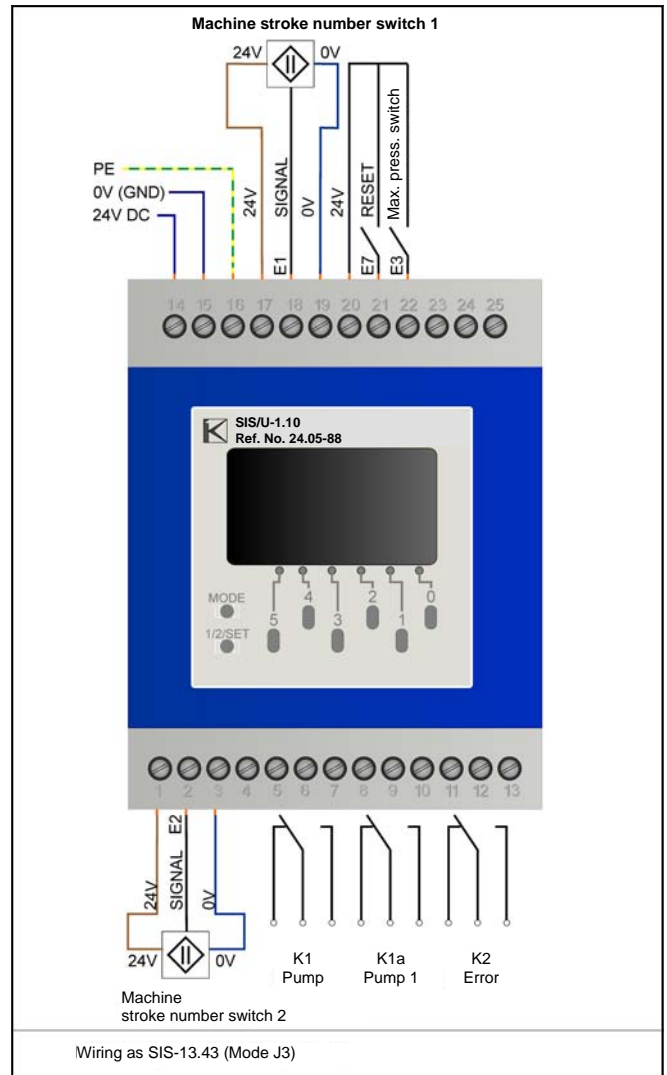

7. Operating Mode J4

7.1 Task

Monitoring of the lubricant flow in central lubrication systems with single lubrication point monitoring.

When selecting this operating mode the function of the controller corresponds to the function of the following devices:

ESU 1/41 Ref. No. 24.01-32

ESU 1/11 Ref. No. 24.01-22

7.2 Function

As soon as the device is switched on, the output relay K2 pulls in and remains in this status when the lubrication pulses are transmitted properly. This is the case if at least 2 positive pulse edges are transmitted during the operating time. The operating time is indicated in the parameter P3. The time range is defined with P9.

If a signal is transmitted to E5, the operating time will be stopped. With intermittently operated central lubrication systems the monitoring of the lubrication pulses can be interrupted by means of a contact for the period of lubrication interruptions.

An error signal remains as long as the power supply has shortly been switched-off and -on, the "OPERATING MODE" key "5" has been pressed or a reset pulse has been transmitted to E7. The reset pulse should at least remain for 10 milliseconds.

Operating Mode J4		ESU 1/41 and ESU 1/11
P1	Not in use	
P2	Not in use	
P3	Operating time in deci-seconds or seconds in dependence of P9	
P4	Not in use	
P5	Not in use	
P6	Not in use	
P7	Not in use	
P8	Not in use	
P9	Range selection 0 = deci-seconds; 1 = seconds	
P10	Not in use	
Input Wiring		
E1	Pulse sensor	
E5	Lubrication interruption contact	
E7	Reset	
Outputs		
K1	Error	
K1a	Error	
K2	Error	
Y1	Not in use	

7.3 Wiring

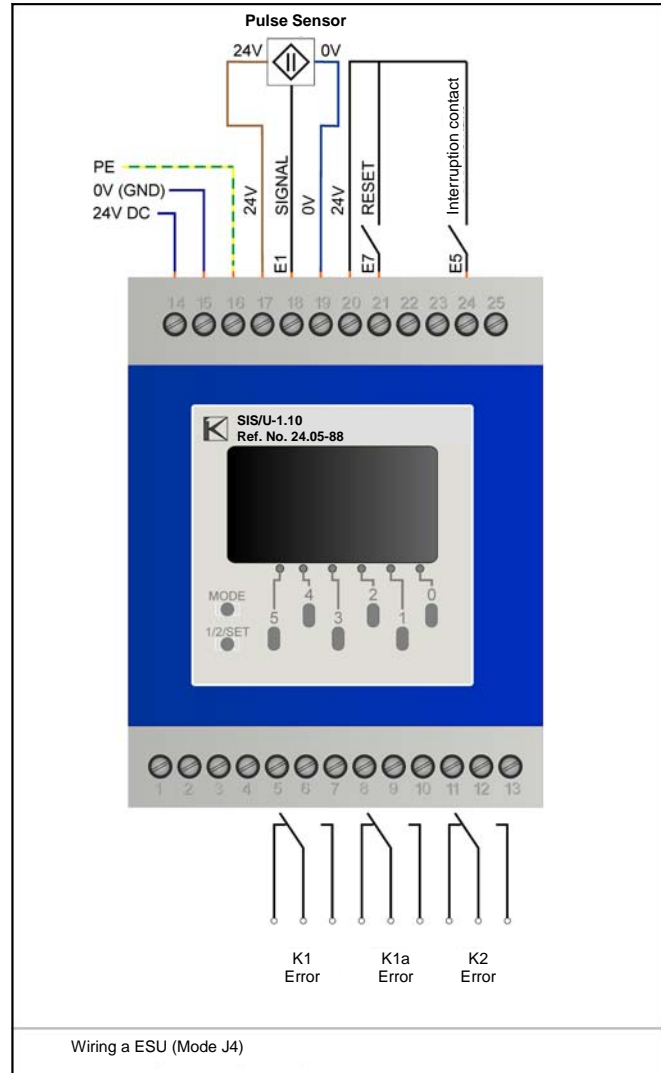

8. Operating Mode J5

8.1 Task

Monitoring of the lubricant flow in machines and plants.

When selecting this operating mode the function of the controller corresponds to the function of the following device:

SUL1 2/43 Ref. No. 24.07-06

8.2 Function

As soon as the device is switched on, the output relay K2 pulls in and signals operational readiness. The two relays K1 and K1a pull in and remain in this status if the lubrication pulses are transmitted properly. This is the case if at least Z positive pulse edges (parameter P1) are transmitted during the operating time (parameter P3).

After Z pulses have been arrived and no error is present a pulse of 0.5s is transmitted to Y1 (stepping pulse).

In case of an error K1 and K1a drop out. For safety reasons it is advisable to switch K1 and K1a in a series. An error signal remains as long as the power supply has shortly been switched-off and -on, the "OPERATING MODE"-key "5" has been pressed or a reset pulse has been transmitted to E7. The reset pulse should at least remain for 10 milliseconds.

Operating Mode J5		SUL1-2.43
P1	Not in use	
P2	Not in use	
P3	Operating time in seconds	1-9999
P4	Not in use	
P5	Not in use	
P6	Not in use	
P7	Not in use	
P8	Not in use	
P9	Not in use	
P10	Minimum pulse number Z	1-999
Input Wiring		
E1	Pulse sensor	
E7	Reset	
Outputs		
K1	Release lubrication	
K1a	Release lubrication	
K2	Release device	
K3	Stepping pulse	

8.3 Time Diagram to Operating Mode J5

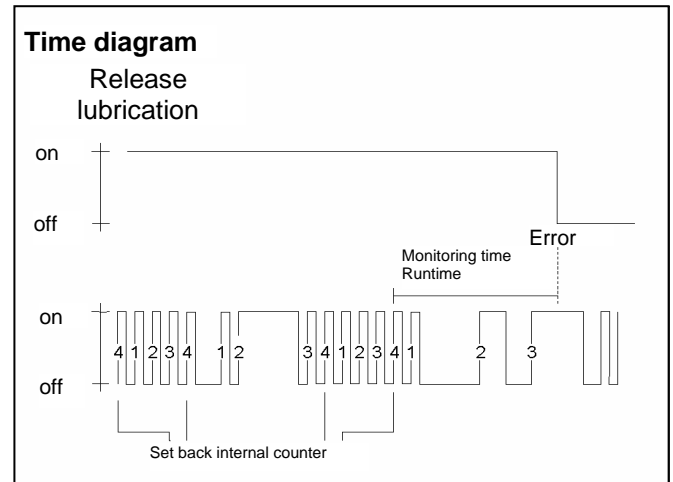

8.4 Wiring

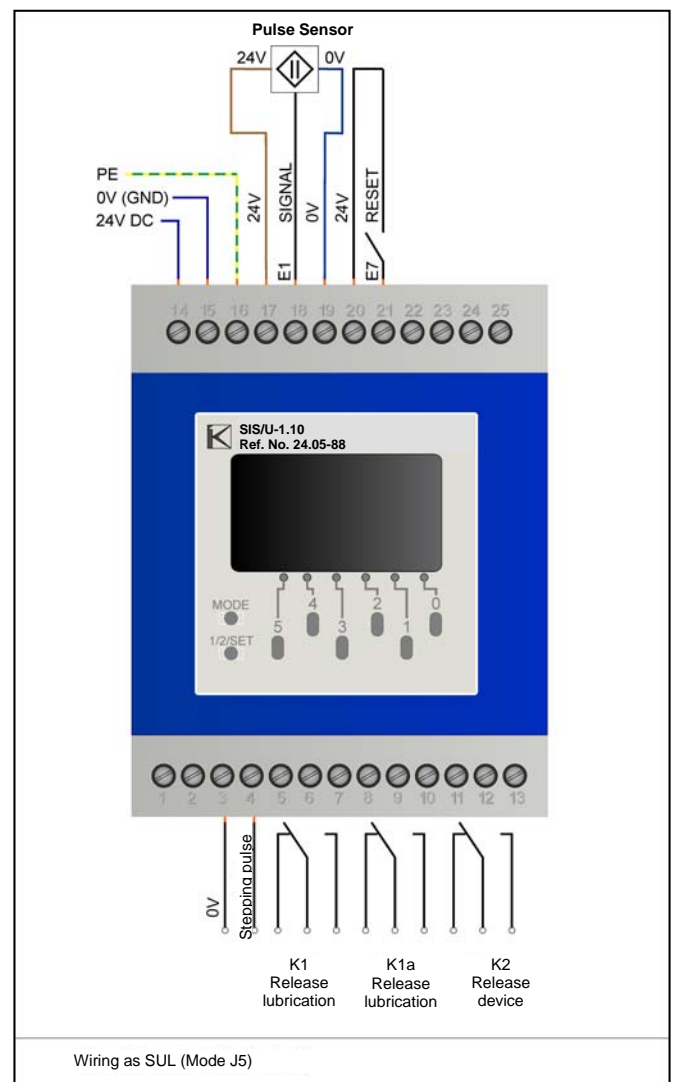

9. Error Index

Error Index	
1	Too many lubrication cycles during interruption time
2	Too little lubrication cycles during the operating period of the pump
3	Lubricant box empty
4	Pressure in the pressure build-up time not reached
5	Min. pressure switch has not responded
6	Max. pressure switch has dropped out with stop-delay
7	Min. pressure switch has dropped out with stop-delay
8	Min. pressure switch has not dropped out after lubrication interruption
9	Max. pressure switch has not dropped out after lubrication interruption
10	Overlapping signals of the stroke number switches
11	Stroke number switch 1 does not transmit pulses
12	Stroke number switch 2 does not transmit pulses
13	Too little monitoring pulses
14	Stroke number difference after interruption cycle

10. Pin Assignment

Pin Assignment	
Terminal	Assignment
1	24 V (COM)
2	E2 (input)
3	0 V (Com)
4	13 V stepping pulse
5	K1 (NC)
6	K1 (Com)
7	K1 (NO)
8	K1a (NC)
9	K1a (Com)
10	K1a (NO)
11	K2 (NC)
12	K2 (Com)
13	K2 (NO)
14	24 V DC supply
15	0 V (GND) supply
16	PE
17	24 V for sensor
18	E1 (input)
19	0 V (Com)
20	24 V (Com)
21	E7 (input) RESET
22	E3 (input)
23	E4 (input)
24	E5 (input)
25	E6 (input)

11. Dimensions

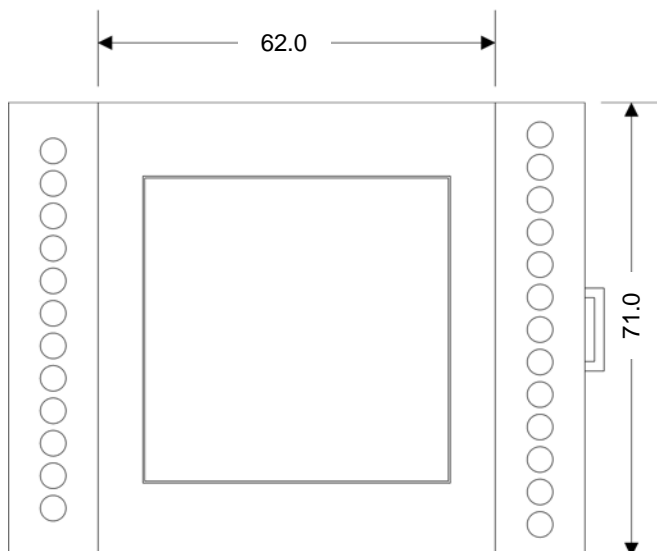
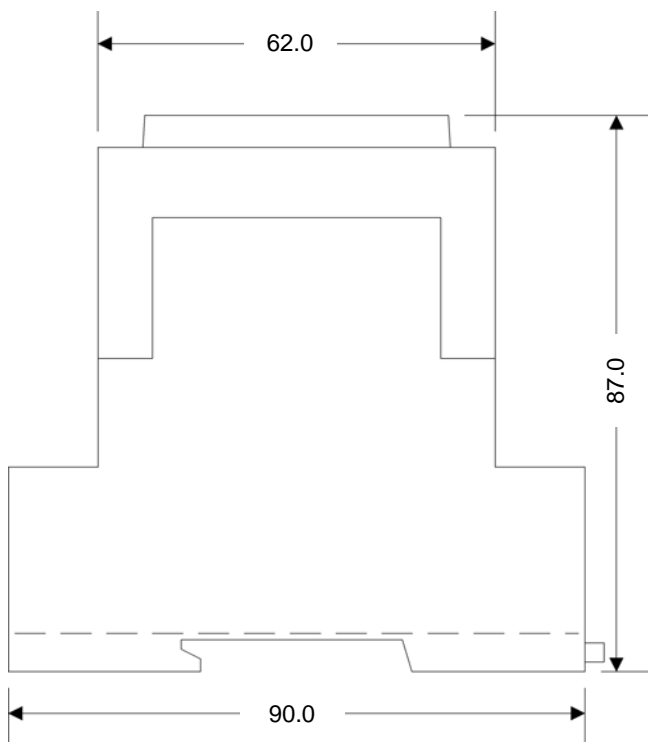

12. Technical data

General data

Permissible operating Voltage DC range	21.6 V DC ... <u>24 V</u> ... 26.4 V DC
Power consumption	approx. 150 mA
Ambient temperature range	0 ... + 55 °C
Storage temperature range	- 20 ... + 70 °C
Max. humidity	30 ... 85 %
Environmental conditions	non-condensing industrial environment, non-dusting, free of corrosive gases
EMC	acc. to EN61131-2
Screw terminal	0.5 ... 2.5 mm ²
Vibration resistance	10 ... 55 Hz, 0.75 mm, 10 min.
Shock resistance	min. 98m/s ²
Housing material	plastic ABS
Dimensions (W x H x D) in mm	71 x 90 x 87 mm
Protection rating	IP 20
Mouting	on DIN hat rail EN 55022
Intended use	industrial controllers
Mounting, commissioning and maintenance	only by qualified staff!

Certifications



Inputs

E1... E2	24 V DC; 3.5 ... 8 mA for pulse sensors
E2 ... E7	for potential-free contacts

Outputs

K1, K1a	relay contacts 230 V 6 A control circuit
K2	transmitting circuit
Y1	electronic output 13 V 4 mA

Order data

SIS/U-1.10	Ref. No. 24.05-88
------------	-------------------

Subject to technical changes!

13. Accessories

Power supply NGS24/15W-1.1 is intended to provide a limited local power supply of devices and sensors that require 24 VDC. The compact plastic housing is suitable for installation in a control cabinet. It is designed to be mounted on a standard rail.

13.1 Dimensions



13.2 Technical data

General data

Permissible operating voltage DC range	100 ... 240 VAC
Power frequency	50 ... 60 Hz
Power consumption e	approx. 300 mA
Output voltage	+ 24 VDC
Tolerance range	± 1 %
Output current	max. 0.63 A
Environmental temperature range	0 ... + 55 °C
Storage temperature range	- 20 ... + 70 °C
Max. humidity	30 ... 85 %
Environmental conditions	non-condensing, industrial environment, non-dusting, free of corrosive gases
EMV	acc. to EN61000-6-3 and EN61000-6-2
Screw terminal	0.5 ... 2.0 mm ²
Mounting material	Plastic
Dimensions (B x H x T) in mm	26 x 89 x 59 mm
Protection rating	IP 20
Mounting	on DIN hat rail EN 55022
Mounting, commissioning and maintenance	only by qualified staff!!
Certifications	CE

Order data

NGS24/15W-1.1 Ref.No. 21.06-54

Subject to technical changes!

We are certified according to DIN EN ISO 9001.