

Diminish Heat Exchanger Maintenance Intervals Due to High Fouling Rates with Continuous Helical Flow Technology™

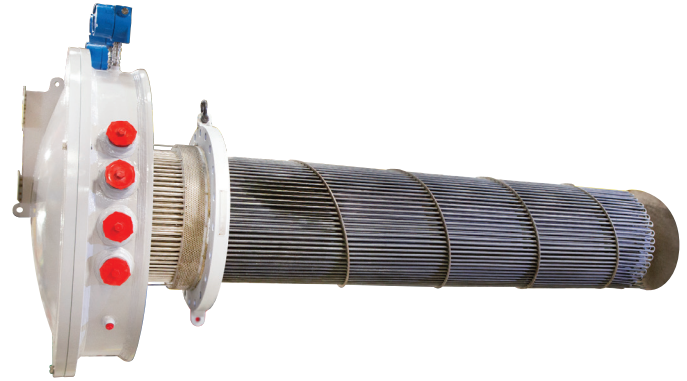

The HELIMAX™ is a next generation heat exchanger with Continuous Helical Flow Technology™ that enables ultra-high heat transfer unlike large, traditional heat exchangers with dead zones. Fluctuations within the heat exchanger to either the sheath temperature or the localized flow rate are common causes of coking, which can lead to system failures and expensive downtime.

Some heat exchanger design methods, like segmental baffles, have known dead zones where hot spots can occur, accelerating the coking process. The HELIMAX provides better performance and longer heater life in a smaller footprint allowing you to reduce maintenance intervals leading to increased productivity.

Performance Capabilities

- Unit wattages: Up to 5 MW
 - System wattages: Up to 200 MW*
 - Voltages: 690V
 - Design temperatures: Up to 1742°F (950°C)
 - Design pressure: Up to 3000psi (206 bar)
 - Maximum ambient temperature: 176°F (80°C)
 - Maximum ambient temperature: -76°F (-60°C)
 - Media phase: Single-phase liquids and gases
- * Multiple system configurations can include multiple units in parallel, in series or a combination of these

Features and Benefits

Continuous Helical Flow Technology™

- Industry-leading heat transfer (two to three times factor improvement compared to legacy technologies)
- Enables lower skin and shell temperature rise above the process fluid compared to segmental baffles
- Offers the ability to push the limit on high outlet temperature applications (above 600°C operating temperatures)
- Minimizes fluid bypass
- Assures tighter sheath temperature control
- Provides smaller shell diameter
- Leads to higher pressures without going to exotic vessel designs
- Offers ability for retrofit with field measurements of existing shell

Reduces coking and fouling

- Eliminates dead zones assuring tighter sheath and shell temperature control
- Creates lower skin temperatures
- Improves the velocity profile on the elements

Overall weight and size reduction

- Able to greatly reduce the overall size of the heat exchanger or quantity of system units required
- Enables significant benefit to space constraint applications in offshore platforms and floating production storage and offloading vessels
- Improves ability to reduce superstructure size and weight

Typical Applications

- Hot oil
- Gas regeneration
- Steam superheating
- Syngas heating
- Mole sieve regeneration
- Fuel gas
- Waste gas
- Crude oil
- Molten salt
- Catalytic regeneration
- Supercritical CO₂ or gas
- Polyphenols-generic add
- Diesel

Helical Flow Diagram

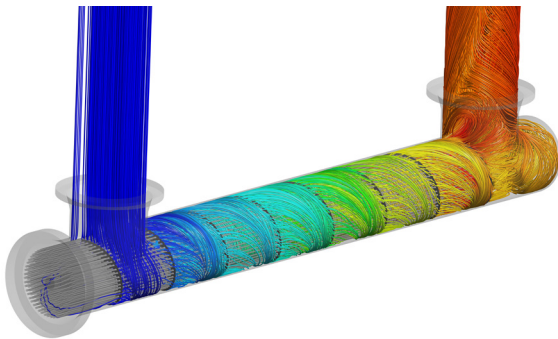

Specifications

Terminal Enclosures

- Standard materials: Alloy 800H, 316SS, 304H, carbon steel
- Standard sizes: 8 to 24 nominal pipe size (NPS)
- Sensing: High limit skin temperature, inlet/outlet process, exposed metal surface temperature, shell (pressure vessel) temperature, terminal enclosure temperature
- Orientation: Horizontal, vertical
- Multi-heater configuration support: Dual, triple and quad stacked, dual-ended vessel
- Standard external mechanical insulation: Fiberglass, mineral wool, calcium silicate
- Control panels: Compatible with WATCONNECT® (see WATCONNECT® specification sheet)
- Pressure vessel: See performance capabilities. Designed to ASME VII- Div 1 and 2, PED, CRN
 - Standard to schedule 160 and flange to Class 2500

Hazardous Area Ratings

- ATEX 2 G Ex d IIC, T1 – 6 Gb
- IEC Ex d IIC: T1 – 6 Gb
- ATEX 2 G Ex e IIC T1 – 6 Gb
- IEC Ex e IIC T1 – 6 Gb
- Class 1, Divisions 1 & 2, Groups B, C & D

Certifications



Vessel Dimensional Drawing

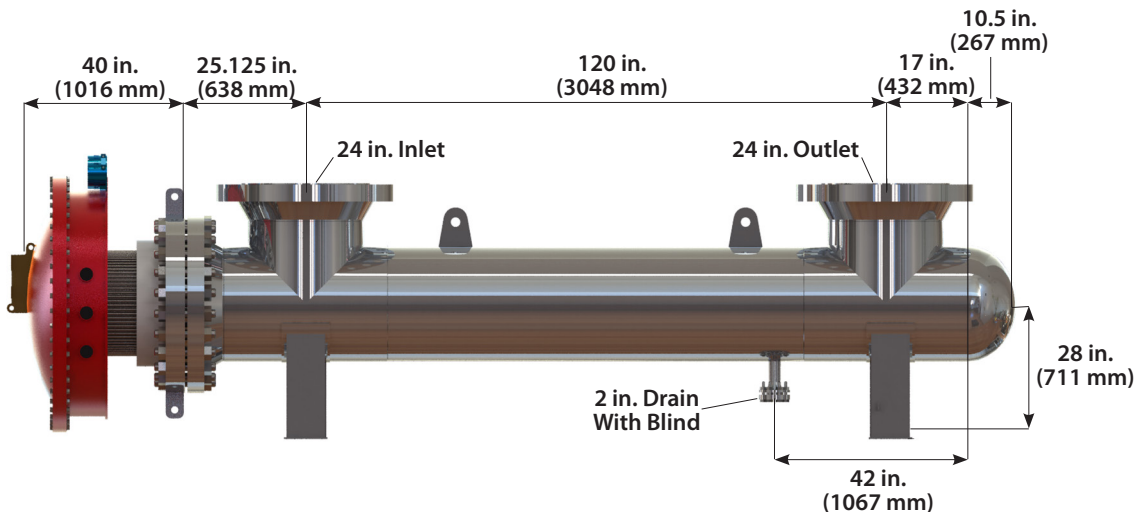

Powered by Possibility



To be automatically connected to the nearest North American Technical Sales Office:

1-800-WATLOW2 • www.watlow.com

International Technical Sales Offices:

Austria	+43 6244 20129 0	India	+91 40 6661 2700	Mexico	+52 442 256 2200
China	+86 21 3532 8532	Italy	+39 02 458 8841	Singapore	+65 6773 9488
France	+33 1 41 32 79 70	Japan	+81 3 3518 6630	Spain	+34 91 675 1292
Germany	+49 7253 9400 0	Korea	+82 2 2169 2600	Taiwan	+886 7 288 5168
				UK	+44 115 964 0777