

ProcessProbe™

ProcessProbe™ Dissolved Oxygen Sensor

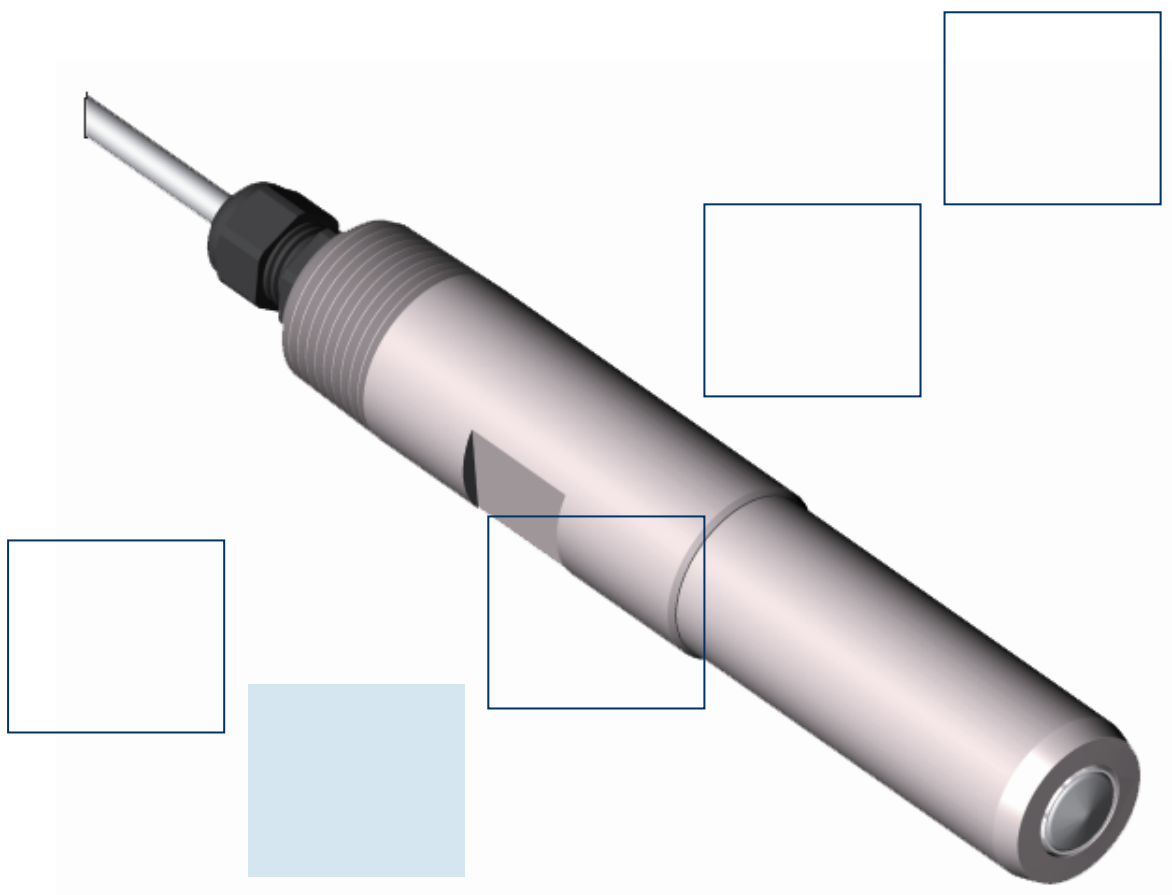

Features

- Robust reinforced membrane
- Simple cartridge membrane replacement
- Flat face obstruction-less measurement
- Low cost of ownership
- Proven performance
- Suitable for many applications including
- Waste treatment
- Sewage aeration
- Rivers, Reservoirs and Boreholes
- Fish farming applications

The body is machined from CPVC with integral 0.75" NPT Male threads for easy installation. It also has a built-in thermistor for automatic temperature compensation.

The dual-layer membrane is reinforced with stainless steel mesh. This mesh helps the membrane resist damage from particulates in the process stream, extending the longevity of the sensor.

The construction of the ProcessProbe™ dissolved oxygen sensor provides a measurement system that is ideal for use in variable flow conditions or applications of extended duration.

The sensor comprises of a silver anode tube positioned over a glass rod into which is fused the platinum cathode. The tip of the glass rod is ground to a precise hemispherical curve that supports the membrane and ensures an optimum pressure is maintained between the membrane and the cathode.

With most oxygen sensors the output is lower in stagnant solutions than in agitated ones. This is due to the sensor consuming oxygen and creating a depletion layer in the proximity of the cathode. In a stagnant solution if the sample is not updated faster than the sensor consumes the oxygen a lower output results. A high degree of flow dependence occurs with sensors that have large cathodes or thin and highly permeable membranes. The membrane construction of the ProcessProbe™ consists of a thin PTFE layer and a relatively thick steel mesh reinforced silicon layer. The silicon layer is highly permeable to oxygen and provides an oxygen reservoir

The double thick PTFE/Silicon membrane therefore acts as an effective buffer against disturbances caused by flow variation. This provides a robust membrane assembly, which has virtually no flow dependence.

The ProcessProbe™ DO sensor has been designed for use in any process stream or wastewater application. The modular design of the membrane assembly makes regular maintenance simple and fast.

For simple maintenance the membrane is supplied as a cartridge, which is held in place by a screw on sleeve. To replace, the cartridge is filled with electrolyte and any entrapped air is forced out when it is gripped between the thumb and forefinger. It is then slid over the end of the anode cathode assembly and the sensor sleeve forces the membrane cartridge against the conical silicon washer. At the same time optimum pressure of the gas permeable membrane against the cathode is obtained.

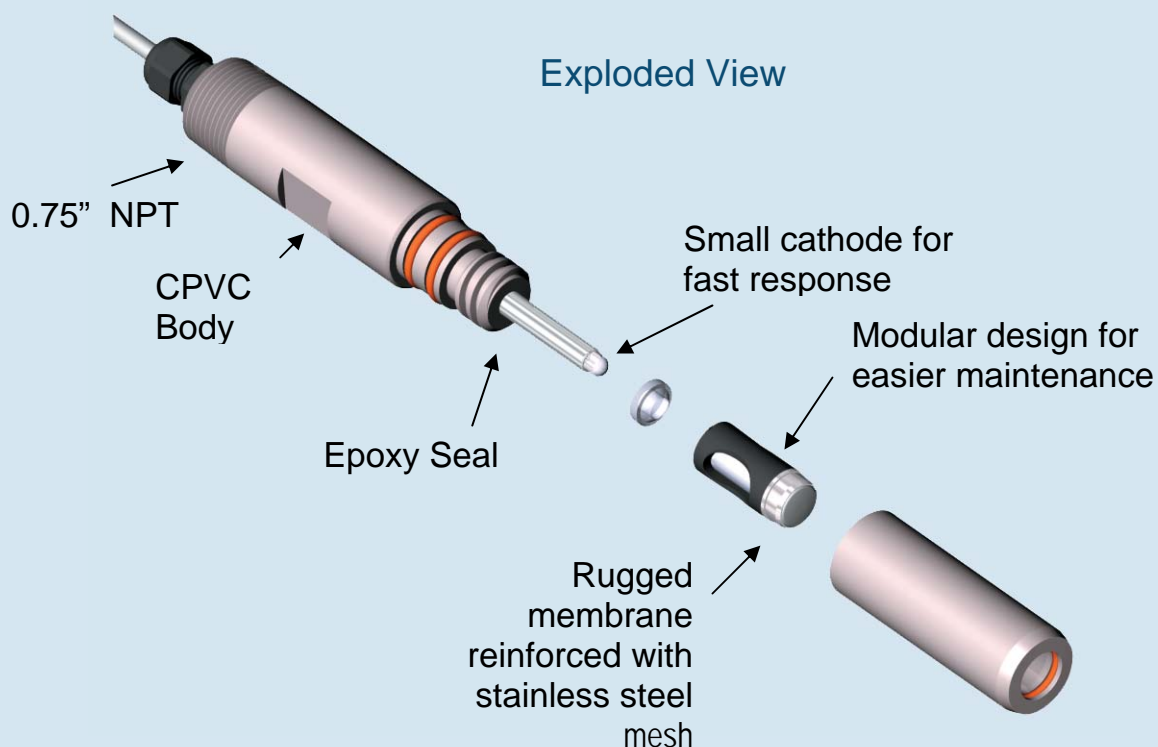

Mounting Options

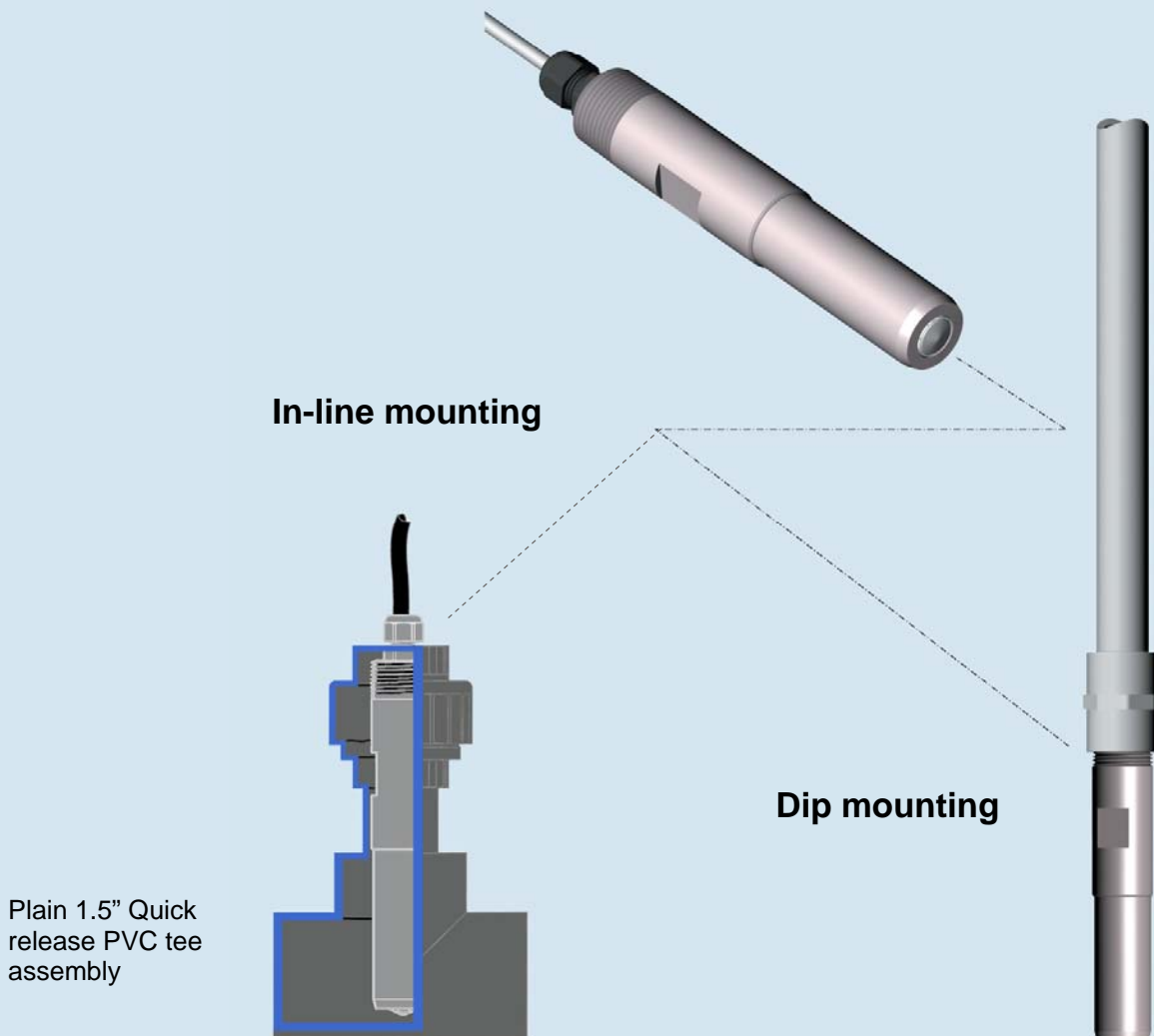

Plain 1.5" Quick release PVC tee assembly

Spares

Single Cartridge Kit

This kit includes everything required to replace the membrane cartridge and internal o-rings on one 25 mm or 19 mm OxyProbe®.

This kit includes:

- One 25 ml bottle of electrolyte
- One membrane cartridge
- One set of internal o-rings

Four Cartridge Kit

This kit contains everything required to replace four membrane cartridges on any combination of 25 mm or 19 mm OxyProbes®. Everything is conveniently packed in one box for easy storage.

This kit includes:

- One 25 ml bottle of electrolyte
- Four membrane cartridges
- Four sets of internal o-rings



Specifications

Sensor Body	CPVC body with 0.75" NPT thread
Membrane	PTFE/Silicone (Steel mesh reinforced)
O ring seals	Silicone Rubber
Wetted materials	CPVC, 316L stainless steel, silicone
Membrane cartridge	High temperature resistant plastic (PPS).
Cathode	Platinum (Pt).
Anode	Silver (Ag).
Electrolyte	KOH / KCl solution pH 13.
Response time	98% of readout in 60 seconds at 25°C, 20 seconds at 37°C
Stability	In water under constant pressure and at a constant temperature drift amounts to less than 2 % per week
Flow dependence	Readings in stirred and unstirred solution differ by approximately 3 - 5%.
Polarisation time/voltage	Overnight (approximately 8 - 12 hours) - 675 mV.
Electrode current in ambient air saturated	Approximately 60 x 10 ⁻⁹ amps.
Electrode current in N2 (zero)	< 1% of current in ambient air.
Temperature coefficient of membrane at constant O2 partial pressure	Approximately 2.3%/K° at 25°C.
Temperature range	0 - 80°C.
Temperature compensation	Automatic with built in thermistor 22Kohms at 25°C.
Linearity	<0.3% of readout.
Maximum pressure	4 bar (atm) 58 psig.

Order Codes

Part No	Description
E-1733-SAM-D10FF	ProcessProbe™ Polargraphic Dissolved Oxygen sensor with built in temperature compensation and fitted with 3 metres of cable and tag ends.
E-1733-SAM-D33FF	ProcessProbe™ Polargraphic Dissolved Oxygen sensor with built in temperature compensation and fitted with 10 metres of cable and tag ends.
KA2501	Spare single cartridge kit comprising of one bottle of electrolyte, one membrane cartridge & one set of internal o-rings
KA2504	Spare four cartridge kit comprising of one bottle of electrolyte, four membrane cartridges & four sets of internal o-rings

Note: Temperature, pressure and solution composition will influence the life expectancy of the measurement sensor.



These products comply with current European Directives

LTH Electronics Ltd reserves the right to make changes to this data sheet or the product without notice, as part of our policy of continued developments and improvements. All care has been taken to ensure the accuracy of information contained in this data sheet. However we cannot accept responsibility for any errors or damages resulting from errors or inaccuracies of information contained herein.

