



EN

IST-5400.AN01.02

File: IST-5400.AN01.02_AN400-I (REV-2012-IT) EN.docx

GAS LEAK DETECTION IN COMBUSTION CHAMBER

AN400/I

USER INSTRUCTIONS

TECNOCENTROL S.r.l.

Via Miglioli, 47 20090 SEGRATE (MI) Italy- Tel. (+39) 02 26922890 - Fax (+39)02 2133734

http: www.tecnocentrol.it

e-mail: info@tecnocentrol.it

IMPORTANT NOTE

Please read and keep care of this manual

All documentation relating to gas detection plant should be preserved, because it contains the procedures to be used during the routines verification and / or during the periodic calibration.

CONTENTS

DESCRIPTION	2
OPERATING PRINCIPLE	4
INSTALLATION	5
USING THE UNIT	6
WARNINGS	6
DIGITAL DISPLAY (ID250/PM) – Use and adjustment of the alarms	6
SENSOR AND CONTROL BOARD OF THE TS292PM - Operation	7
ROUTINE MAINTENANCE	8
SCHEDULED CHECKS	8
MAINTENANCE	8
DRAINING THE CONDENSATE FILTER	8
REPLACING THE COALESCER FILTER	8
REPLACING THE PROTECTION FILTER	8
CLEANING THE SUCTION PIPE	8
RESETTING THE GAS SENSOR	8
SPARE PARTS	8
ASSISTANCE	<i>Errore. Il segnalibro non è definito.</i>
TECHNICAL CHARACTERISTICS	9
1- Wiring and Gas Analysis Diagram (Base Plate)	10
NOTE: Wiring and Gas Analysis Version for Pump (Right Side)	11
2- Wiring and Gas Analysis Diagram (Right Side)	11
3- Wiring and Gas Analysis Diagram of the Door	12

<i>Documento / Document name:</i> IST-5400.AN01.02_AN400-I (REV-2012-IT) EN.docx			
<i>Oggetto / Subject :</i> AN400/I (EN)			
<i>Rev.</i>	<i>Data / Date</i>	<i>Da / By</i>	<i>Notes</i>
0	12/12/2013	UT/	New Translation

DESCRIPTION

The **AN400/I** unit measures, displays and transmits, in the form of a 4-20 mA signal, the concentration of flammable gases in the combustion chamber.

The analyser comprises a metal wall-mounted cabinet, with glass door and IP55 protection, measuring 400x500x200 mm. On the front panel is an illuminated power switch, a digital display that indicates the concentration of explosive gas, and a flowmeter that regulates the flow of gas to the sensor.

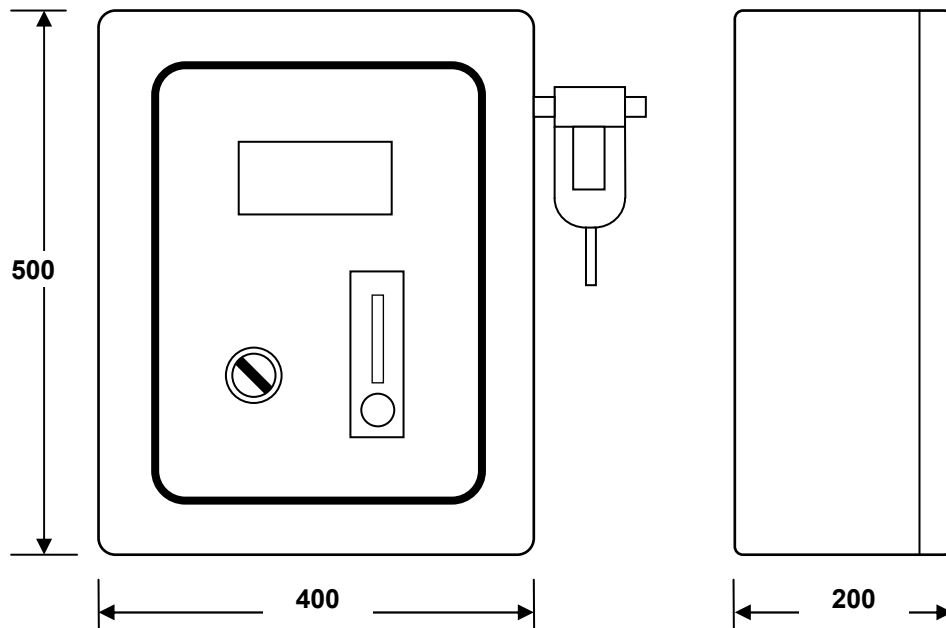

The latter is a catalytic combustion sensor (Pellistor) designed to detect methane gas.

The gas analysis circuit in the combustion chamber of the AN400/I comprises a **coalescer filter** to remove condensate, a **suction pump**, a **three-way valve**, a **flowmeter**, a protection filter and a **Pellistor sensor** for explosive gas.

The **AN400/I** unit cleans the gas sensor with clean air every time the burner starts up (at the end of each analysis cycle). The cleaning process takes about 3-4 minutes and is controlled by a **Timer**.

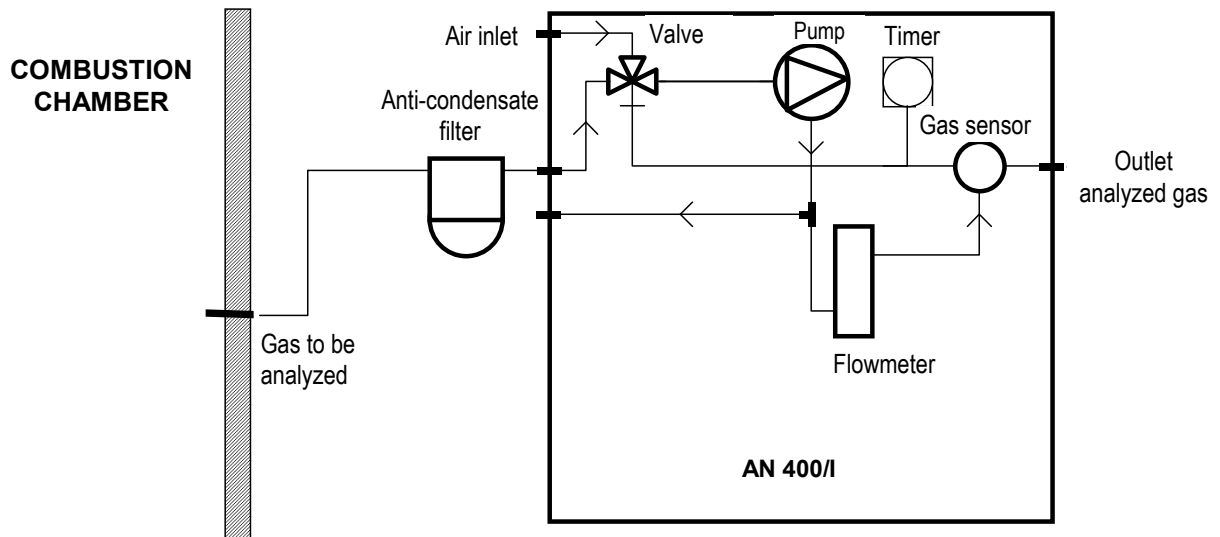

OPERATING PRINCIPLE

The sensor is enabled only when the burner is turned off and can potentially leak non-combusted gases.

The **AN400/I** has two relay outputs. There is one pre-alarm (**AL1**) dry contact output configured at a concentration of 10% of the LEL of Methane and a normally energised dry contact output that disables the burner (**AL3**) when the concentration exceeds 30% of the LEL of Methane or when there is a fault with the sensor. These alarm thresholds can be modified as instructed on page 6.

The normally energised safety relay (positive safety) protects the system in the event of a fault with the analysis unit.

If the sensor does not detect a hazardous concentration of gas, the burner disable relay remains energised and combustion can begin.

If the sensor does detect gas in the combustion chamber, the burner disable relay is de-energised to prevent the burner from starting up.

This status does not change until the concentration of gas in the combustion chamber falls below the threshold and you have turned off the alarm by pressing, for about 5 seconds, the **RESET** button on the unit display.

The system also has a timer and a three-way valve for cleaning the sensor with pure air, for a period of about 3-4 minutes, when the burner starts up (at the end of each analysis cycle).

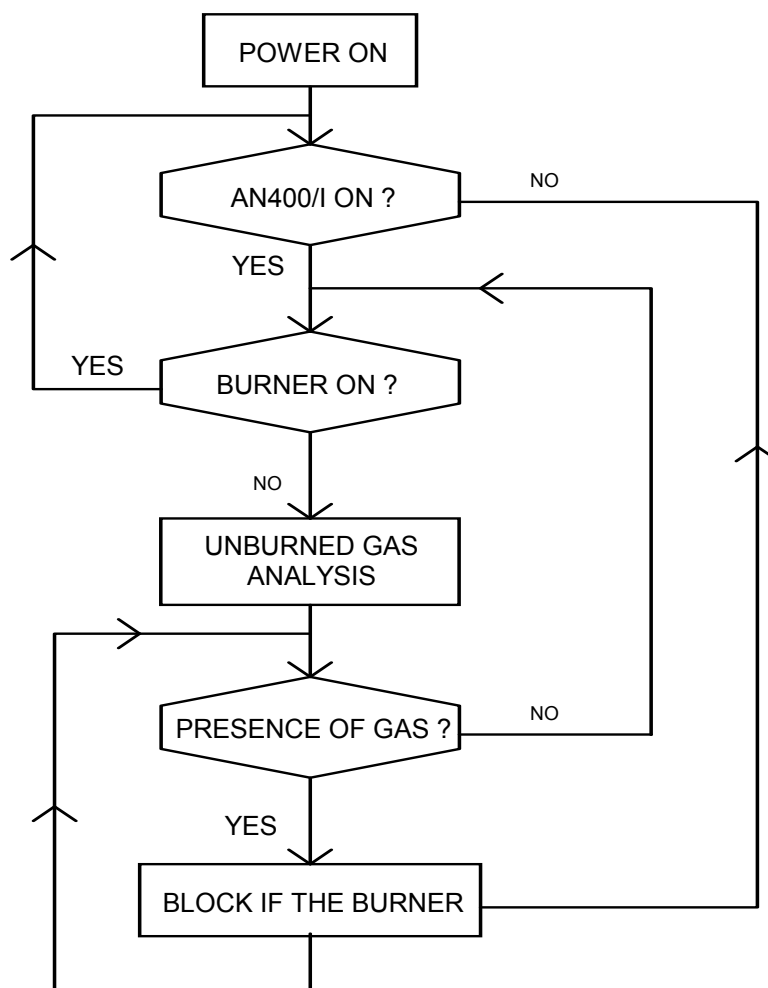

INSTALLATION

Position:

Install the **AN400/I** near the burner to be analysed, taking the operating environmental conditions into account. The temperature in the area concerned should not exceed 45°C, irrespective of the distance between the point of analysis and the point of installation.

Gas analysis connection: Connect the gas sampling point of the combustion chamber to the AN400/I unit with a 6x8mm pipe preferably made of stainless steel or PTFE.

The AN400/I unit should be situated no further than 10 metres away from the sampling point.

Install a pipe fitting (with an external diameter of 8 mm) in the combustion chamber.

You are advised to assemble the pipe at a slight downwards angle from the AN400/I unit so that any condensate can flow back towards the combustion chamber.

Next, connect the pipe to the fitting on the inlet filter of the AN400/I unit.

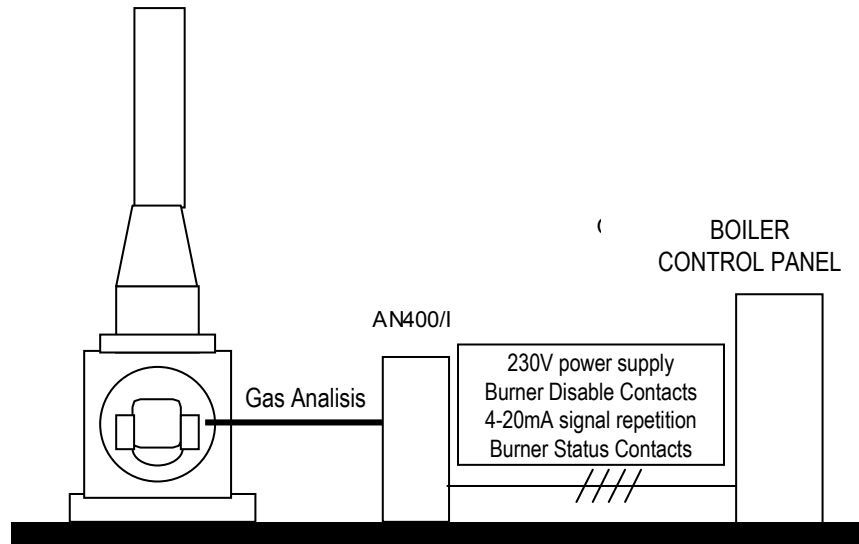

Electrical connections: Make the connections to the terminal block of the AN400/I unit for the supply of power, the alarm and burner enable / disable contacts, and for possible repetition of the 4-20mA signal. (In the case of connection to an AN750 unit, refer to the specific instructions)

Terminal	Connection	Wire
T	Earth	2.5 mm ² Gr-Ye
L	Phase	1.5 mm ² Black
N	Neutral	1.5 mm ² Blue
1-2	Burner Enable Contacts	2 x 0.75 mm ²
3	"+" output of the 4-20 mA gas signal for the chamber	2 x 0.75 mm ² (screened)
4	"-" output of the 4-20 mA gas signal for the chamber	
5	C (common) contact of the Pre-alarm relay	2 x 0.75 mm ²
6	NO (normally open) contact of the Pre-alarm relay	
7	NC (normally closed) contact of the Pre-alarm relay	
8	C (common) contacts of the Burner disable relay	2 x 0.75 mm ²
9	NC (normally closed) contacts of the Burner disable relay	

230Vac power supply: connect the power cord to terminals L, N and T.

Burner enable contact: this contact must be closed when the burner is running and open when the burner is turned off.

4-20mA output: terminals 3 and 4 must be short-circuited (jumper) if this signal is not used.

the 4-20 mA output signal is available over two wires and corresponds to a 0-100% scale of the LEL of Methane (CH₄), with a maximum load of 200 Ohm.

Pre-alarm output: terminals 5, 6 and 7 are the contacts of the pre-alarm relay normally used to enable a visual/acoustic alarm.

Burner Disable Output: terminals 8 and 9 are the contacts of the alarm relay used to disable the burner when gas is detected in the combustion chamber.

After all these connections are made, the unit is ready to analyse gas in the combustion chamber.

USING THE UNIT

Start-up: Turn ON the illuminated switch to power the AN400/I unit.

The digital display (ID250/P) on the front of the unit starts up and the flowmeter indicates the suction pump is also running. If necessary, set the flowmeter at about 0.3 l/m.

Pre-heating: when you power the AN400/I unit, the sensor takes about 60 seconds to warm up; it is then ready to detect gas but requires 4 hours' continuous operation to reach optimum conditions of stability. (NOTE: The yellow "FAULT" LED on the control board in the cabinet blinks while the sensor warms up; it then turns off and the green "ON" LED remains steady indicating normal operation).

Important: After installation, power the unit and wait for about 20-30 minutes to allow the sensor to adapt to the environmental conditions. Reset only if necessary (refer to the chapter **Checks and Calibration**).

WARNINGS

The mean operating life of the sensor in clean air is 3-5 years. After this period of time, or when the instrument no longer passes the scheduled checks using the cylinder of titrated gas (refer to the chapter **Checks and Calibration**), you simply need to replace the **Sensor Cartridge**.

(NOTE: In any case, after five years of use, the yellow FAULT LED on the control board in the cabinet will blink every 4 seconds to indicate the need to replace the "Sensor cartridge".

Scheduled Checks: You are advised to carry out, once a year: the detector functional test, the electrical test, the reset process and the check and calibration with the Methane Gas/Air mixture. Refer to the section **Checks and Calibration**.

DIGITAL DISPLAY (ID250/PM) – Use and adjustment of the alarms

Operation: The display of the ID250PM indicates the gas concentration value received via the 4-20mA signal from the sensor control board in the cabinet. Press the keys "ALARM 1" or "ALARM 2" or "ALARM 3" to view the relative alarm thresholds on the display. (NOTE: Alarm 2 is not used and is not present on the terminal block, but is normally set at 20% of the LEL).

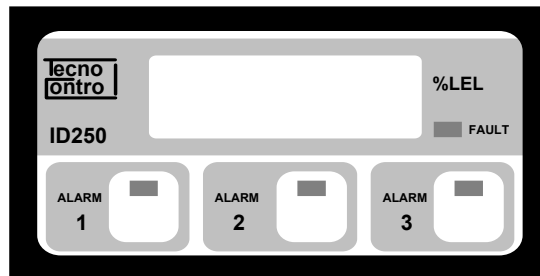

Alarms: the thresholds of the ID250PM are pre-set as indicated in the Table below. These can, however, still be modified to any point of the scale as indicated in the section **Adjusting the alarms**. When the signal exceeds one of the set alarm thresholds, it triggers the relative red LED and relay (**PRE-ALARM Terminals 5-6-7 and BURNER DISABLE Terminals 8 and 9**).

Enabling of the **BURNER DISABLE** relay is delayed by 20 seconds after the third alarm threshold is exceeded, to avoid accidental disabling of the burner (false alarms).

To turn off ALARM 3, press and hold the RESET button for about 5 seconds only after the concentration of gas has fallen below the threshold.

Alarm Table

Model	Scale	ALARM 1	ALARM 2	ALARM 3
ID250PM (%LEL)	0 - 100 %	10 %	20 %	30%

Faults: If the input value is below 0.5 mA (e.g. due to a fault with the sensor or control circuit), the yellow FAULT LED is illuminated and the BURNER DISABLE control (terminals 8 and 9) is triggered. The FAULT relay is also de-energised in the event of a power cut or fault with the power circuit of the AN400/I, to prevent the burner from starting up.

Adjusting the alarms: The alarm thresholds can, if necessary, be modified as follows. Prise open the front frame with the data plate. Press and hold the "AL1" button and, using a suitable small flat-head screwdriver, turn the "SET ALARM 1" trimmer next to it to set the required value on the display.

The same can be done with the "SET ALARM 3" trimmer to modify the threshold of "ALARM 3". When you have done, put the frame with the date plate back in place, pushing it in around the edges.

WARNING: The alarm thresholds should be modified only by qualified personnel to guarantee that the burner disable relay is always triggered when there is gas in the combustion chamber.

TECNOCENTROL S.r.l. cannot be held responsible for failure of the instrument to work due to improper configuration of the alarms or poor or insufficient maintenance.

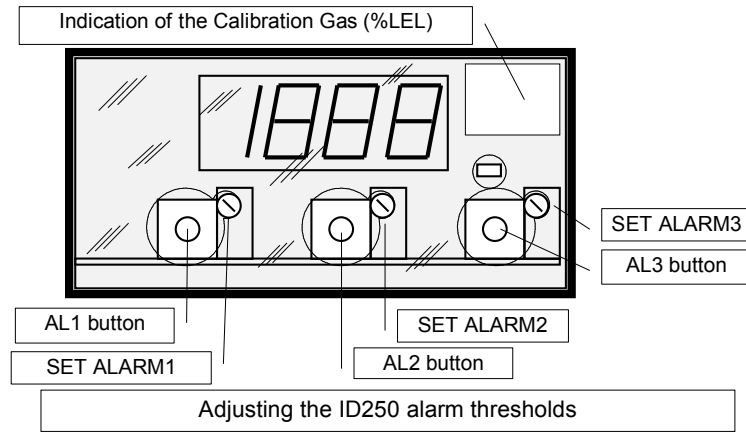

Scheduled Checks: The display of the **ID250/PM** is calibrated at the factory and does not require calibration after installation. You are advised to carry out a functional test once every 2 years. Simply use a mA multimeter (20mA scale) connected in series to the 4-20mA signal to check the mA reading is the same as the value on the Display.

SENSOR AND CONTROL BOARD OF THE TS292PM - Operation

The sensor and control board are located, respectively, in the top left and top right corners of the base plate in the cabinet.

Keys F1 and F2 on the cover of the control board are for checks and calibrations only with code, and the three LEDs indicate the operating conditions:

- Red ALARM LED:** Visual alarm signal at the set value of 20% of the LEL.
- Green ON LED:** Normal operation.
- Yellow FAULT LED:** The sensor is faulty, disconnected, at full scale, or expired.

The sensor is designed to detect Methane (**CH₄**), a combustible gas lighter than air. Its density with respect to dry air is 0.55 and its LEL is at 4.4% v/v (% volume).

Normal operation: Only the green LED (ON) should be illuminated.

The Red (ALARM) LED, when enabled, is illuminated only when the concentration of gas exceeds 20% of the LEL.

The possible faults, listed below, trigger the yellow (FAULT) LED and set the "S" output at 0mA, enabling the fault control function on the **ID25/PM digital display**.

The Yellow LED blinks once every 4 seconds (with the Green LED steady): to warn that the "Sensor Cartridge" has reached the end of its lifespan (about 5 years) and is no longer guaranteed to work correctly. The detector will continue to work normally, but you need to replace the Sensor Cartridge with a new one as soon as possible. The type of Sensor Cartridge required is indicated in the spare parts table on Page 8. The replacement procedure is described in the documentation provided with the Sensor Cartridge.

If the Yellow LED is illuminated and the Green LED is off (0mA output): This indicates any of several possible faults: **1)** The "Sensor Cartridge" is faulty: replace it with a new one. **2)** If a new "Cartridge" has been installed: it is either connected incorrectly, or is incompatible. Check that the cartridge is connected properly and compatible (refer to Page 1 Technical Characteristics). When you have done, turn the AN400/I unit off and then on again. If the problem persists, the unit may need to be repaired.

If the Yellow and Green LEDs are illuminated (0mA output): this indicates a probable fault with the "Sensor Cartridge". First of all, attempt the "Reset" process as instructed in the section "Checks and Calibration", and then turn the unit off and on again. If this does not work, try replacing the "Sensor Cartridge". If the problem persists, the unit may need to be repaired.

If all the LEDs are illuminated (>24.0mA output): This indicates either a fault with the "Sensor Cartridge" or a concentration of gas exceeding the full scale (100%LEL). If there are no gas leaks and this problem persists even after you have replaced the "Cartridge", you will need to return the detector to the supplier for repair.

ROUTINE MAINTENANCE

SCHEDULED CHECKS

- Check the condition of the coalescer filter and the level of condensate on a daily basis.
- Check the calibration of the gas sensor and subject it to a functional test once every 6-12 months.

NOTE: Calibration and maintenance should ideally be carried out by the qualified personnel of the TECNOCENTRAL Assistance Service.

MAINTENANCE

All maintenance operations must be carried out with the burner turned off.

DRAINING THE CONDENSATE FILTER

Remove the cap on the pipe under the filter to drain out the condensate.

REPLACING THE COALESCER FILTER

Unscrew and remove the cup (B) (if this is dirty, clean it with water and soap), replace the filter (C), and reassemble the cup making sure that the O-Ring is positioned correctly between the cup and the body of the filter.

REPLACING THE PROTECTION FILTER

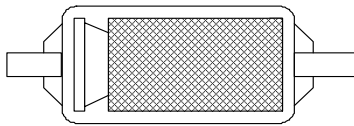

The protection filter is located on the inside of the cabinet door and protects the flowmeter against dust.

Replace the filter when it is dark grey on the inside. Remove the filter and put a new one in its place, making sure to connect it correctly without leaving any gaps.

CLEANING THE SUCTION PIPE

Detach the pipe from the condensate filter and blow compressed air down it (in the direction of the Burner).

RESETTING THE GAS SENSOR

In order to reset the gas sensor, you need to enter the **Code** by pressing the F1 and F2 buttons (see picture) on the control board in the top left-hand corner of the base plate in the cabinet. Press and hold the first button for about a second (until the green LED blinks) to make sure that it responds. You can then press the next button. In the event of an error, simply wait for 10 seconds and the sequence is automatically cancelled.

“RESET” (Reset Code: F2, F1, F1, F2): this allows you to manually reset the sensor when the air is clean (without flammable gases or other pollutants). Do not forget that there is a smart resetter on the sensor control board that resets the sensor every hour when no gas has been detected. Reset, if necessary, after installation or after replacing the cartridge, and after every 6-12 months, depending on the environmental conditions. Enter the **“Zero Code”** to confirm the reset operation. The red LED blinks once, the output is set at 4.0 mA and the Display (ID250/PM) indicates a value of about 0.0 (±0.2).

WARNING: The above cannot be done if the mA value of the output is above 10% of the LEL (5.6 mA) or the red LED is illuminated. In this case, please contact our assistance service.

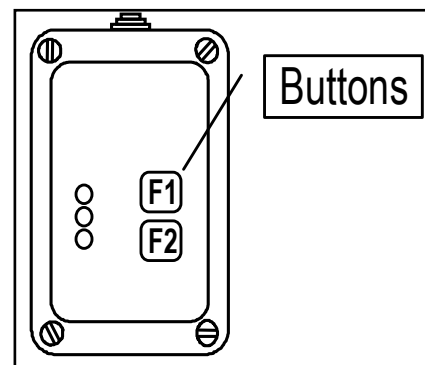

SPARE PARTS

CODE	DESCRIPTION
ZSP02/EX	Replaceable Sensor Cartridge CE400/I (0÷100%LEL)
ZF004	Coalescent cartridge
ZF007	Protection filter
PO220	230VAC Vibration Pump for AN400/I
TU135	3x7mm Silicone Tubing (by the metre)

NOTE: The rate at which you need to replace these parts depends on extent of use of the unit, the type of fuel used, and the execution of routine maintenance.

TECHNICAL SERVICE

TECNOCONTROL can, on request, offer a maintenance contract for the execution of maintenance on an annual or quarterly basis (at the start and/or half-way through the season).

The contract covers the replacement, when necessary, of parts subject to wear, testing of the pump, calibration and/or replacement, when necessary, of the "Sensor Cartridge(s)", and a functional test of the unit.

TECHNICAL CHARACTERISTICS

Power supply	230 Vac (-15/+10%) - 50 Hz ($\pm 10\%$)
Power consumption at 230Vac	40 VA Max
Indicator Display	Numerical LED – Three and a half digits
Current output	Two linear outputs at 4-20mA
Load resistance	200 Ohm max per output
Pre-alarm output 1	Normally energised relay with C-NO potential free contacts
Pre-alarm output 2	Normally energised relay with C-NC potential free contacts
Disable Output (ALARM)	Normally energised relay with C-NC potential free contacts
Fault Output	Normally energised relay with C-NC potential free contacts
Capacity of Relay Output	3 A (resistive) at 230 Vac
Sensors	Two Catalytic sensors (Pellistor)
Range / Calibrated at	0-100%LEL / Ethanol = Ethyl alcohol
Sensor Cartridges	Replaceable (code ZSP02)
Mean sensor life in clean air	5 years
Response time	$T_{90} < 60$ seconds (with 5-metre suction pipe)
Repeatability	$\leq 5\%$ of the signal
Precision	$\pm 5\%$
Linearity	Up to 60% of the LEL
Long-term drift in clean air	$< \pm 4\%$ of the LEL annually
Operating temperature / humidity	-5 to + 50 °C / 10 to 90 % non condensing RH
Maximum period in storage	12 months
Storage temperature / humidity	-20 to + 55°C / 5 to 95 % non condensing RH
Operating pressure	Atmospheric pressure $\pm 10\%$
Degree of protection	IP55
Dimensions	400x500x200mm
Weight	About 25 kg

1- Wiring and Gas Analysis Diagram (Base Plate)

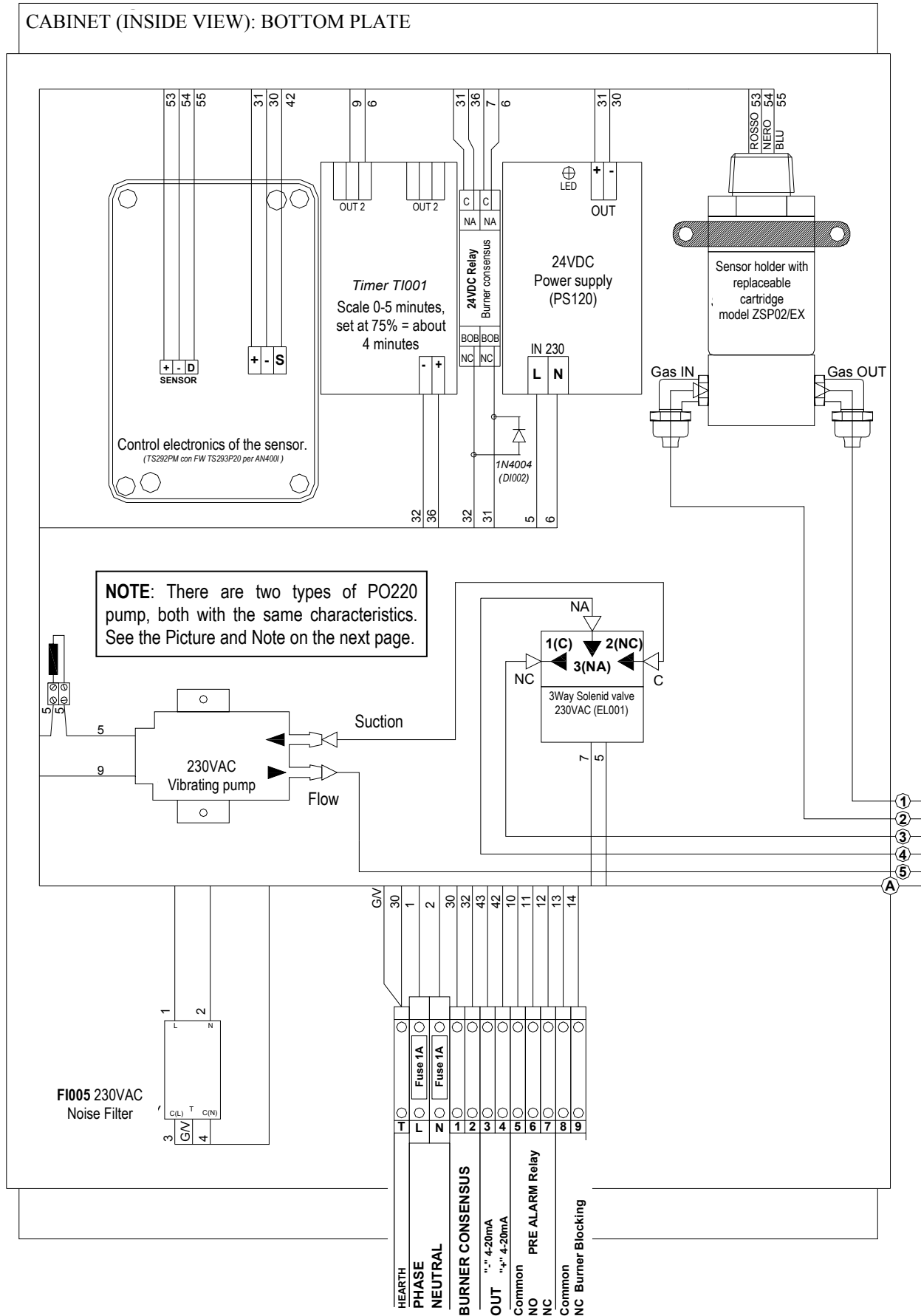

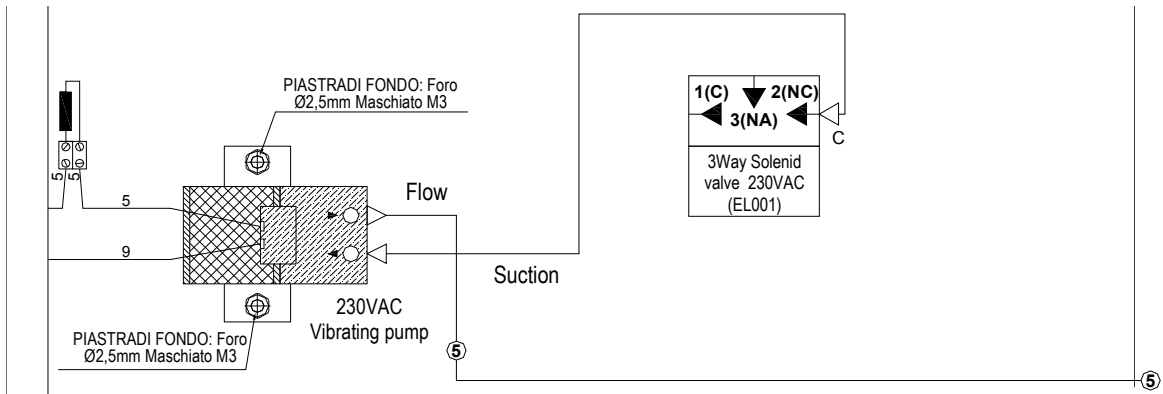

NOTE: Wiring and Gas Analysis Version for Pump (Right Side)

2- Wiring and Gas Analysis Diagram (Right Side)

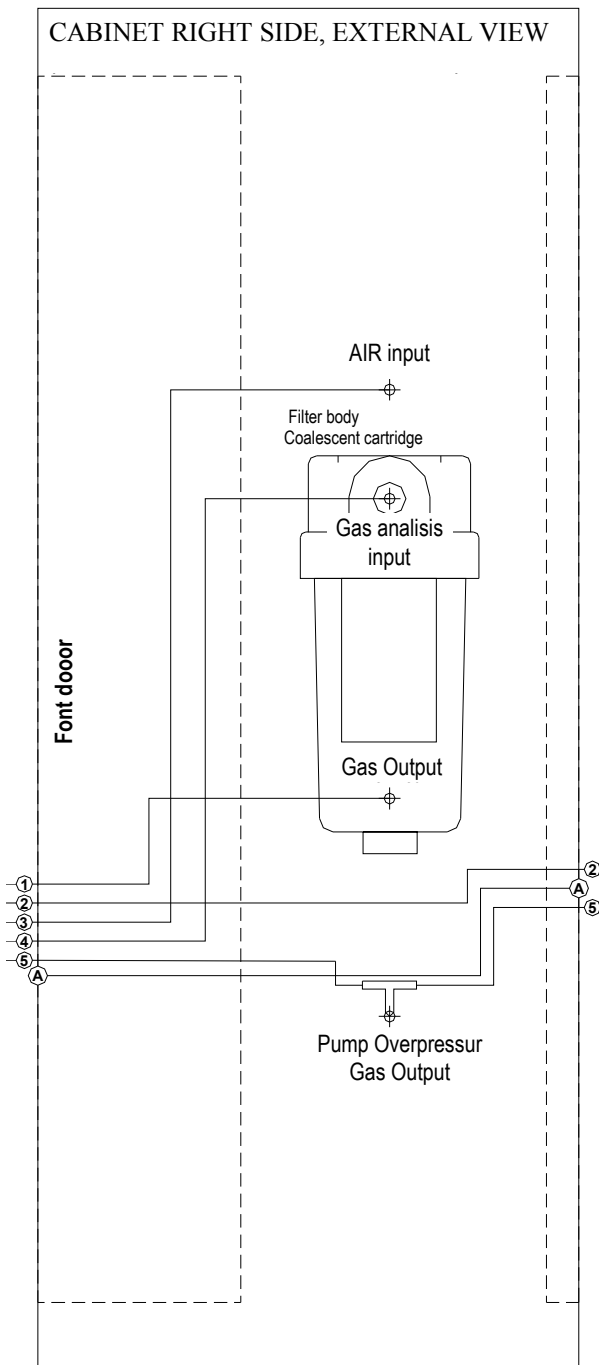

3- Wiring and Gas Analysis Diagram of the Door

CABINET INNER DOOR, INTERIOR VIEW

