



Operating instructions Technical Parameter

multisys

3D2-BSBS



**Interfaces
for 2x KBR Modulbus**



KBR GmbH
Am Kieferschlag 7
D-91126 Schwabach

T +49 (0) 9122 6373-0
F +49 (0) 9122 6373-83
E info@kbr.de

www.kbr.de

Dear Customer

We would like to thank you for choosing a KBR GmbH quality product.

In order to familiarize yourself with the operation and programming of the device and always be able to use the whole functionality of this high-quality product, we recommend that you read this manual thoroughly. The individual chapters serve to explain the technical details of the device and show how to avoid damage by means of proper installation and commissioning.

The manual is included in the scope of delivery of the device and must be accessible for the user at all times (e.g. in the switchgear cabinet). Even when the device is resold to third parties, the manual remains part of the device.

Although we used the utmost care in assembling this manual, we would like to thank you in advance for notifying us about any errors or ambiguous descriptions that might be in it. You will find a form for corrections in the appendix.

Sincerely,

KBR GmbH Schwabach

Safety Precautions

This manual contains notes that must be observed for your personal safety and to avoid damage to equipment. Notes are identified by a warning sign or an info symbol according to the degree of hazard they represent.



Danger

means that death, major injuries or damage **will** occur in case the appropriate safety measures are not performed.



Warning

means that death, major injuries or damage **may** occur in case the appropriate safety measures are not performed.



Caution

means that minor injuries or damage may occur in case the appropriate safety measures are not performed.



Note

is an important information on the product, product handling or the respective part of the user manual to which special reference is made.

Disclaimer

The contents of this manual has been checked with the described hardware and software components. Certain deviations, however, cannot be excluded, so the manufacturer is not liable for complete conformity. The specifications made in this manual are checked on a regular basis, necessary corrections are included in the next revision.

We appreciate your corrections and comments.

© KBR-GmbH
Subject to change

General Safety Precautions

In order to prevent operating errors, handling of the device is kept as simple as possible. This way, you will be able to use the device very soon.

In your own interest, however, you should read the following safety precautions carefully.



Warning

During installation, the applicable DIN / VDE regulations must be observed!

Mains connection, setup and operation of the device must only be performed by qualified personnel. Qualified personnel as understood in the safety precautions of this manual are persons authorized to setup, ground and mark equipment, systems and wiring systems in accordance with applicable standards.

To avoid the hazard of fire and electrical shock, the device must not be subjected to rain or other humidity!

Before the device is connected to the mains, you will have to check whether the local mains conditions comply with the specifications on the manufacturer's label. A wrong connection may destroy the device!

When connecting the device, the connection chart must be observed (see chapter "Connection chart") and the connection lines must be powerless. Only use proper line material and watch the correct polarity when wiring!

In order to ensure proper and safe operation of the product, it must be transported, stored, installed and mounted in accordance with the specifications and operated and maintained carefully.

A device showing visible damage must by all means be considered as unfit for operation and must be disconnected from the mains!

Error detection, repairs and maintenance work may only be carried out in our facilities or after contacting our service team. Every warranty obligation of the manufacturer expires if the device is opened without written consent from our service team. Proper operation can no longer be guaranteed!

Opening the device may expose parts under voltage. Capacitors in the device may still be loaded even if the device was disconnected from all voltage sources. It is generally not allowed to operate the open device!

In facilities subject to hazard of lightning, lightning protection must be provided for all input and output lines (recommendations see chapter "Protective measures")!

Product Liability

With these product, you have acquired a quality product.

In its manufacture, only components of the highest reliability and quality were used. Each device is subject to long-term testing before it is delivered.

For information on product liability, please refer to our General Terms and Conditions for electronic devices.

The warranted properties of the device apply only if it is operated in accordance with its intended use!

Disposal

Please dispose of defective, outdated or no longer used devices properly.
At your request, we will be pleased to dispose of the devices for you.

Table of Contents

1	multisys 3D2-BSBS	2
1.1	Interfaces KBR module bus multisys 3D2-BSBS	2
1.1.1	Module bus connection RJ-12/RS-485	3
1.2	Connection diagram	3
2	Technical data	4
2.1	Power supply	4
2.2	Electrical connection	4
2.3	Mechanical data	4
2.4	Standards and miscellaneous	4

1 multisys 3D2-BSBS

The multisys 3D2-BSBS connects the **KBR** multisys modules with each other. It is used when more than 5 modules are connected on the module bus side of a **KBR** multisys **basis device** (securing the required supply voltage).

The voltage supply for the **KBR** multisys **modules** at the output side is via multisys 3D2-BSBS. The multisys 3D2-BSBS can supply the operating voltage for a maximum of 5 modules.

The multisys 3D2-BSBS is equipped with a power LED for supply voltage monitoring, a power supply (85 to 265V AC/DC; 2VA) and is suitable for wall mounting on a 7.5 mm deep DIN rail, in accordance with DIN EN50022 (for distribution board mounting).



Note

If two gateways are used (multisys 3D2-BSES and multisys 3D6-ESBS), the module bus distance can be extended to 1,000m maximum (RS-485 standard).

1.1 Interfaces KBR module bus multisys 3D2-BSBS

The two interfaces RJ-12 / RS-485 are galvanically separated from each other. The RJ-12 /RS-485 interfaces are set to the parameters 38400 baud, 8 data bits, parity even, 1 stop bit. They can be terminated using two 4-fold DIL switches (terminating resistors are integrated into the multisys).

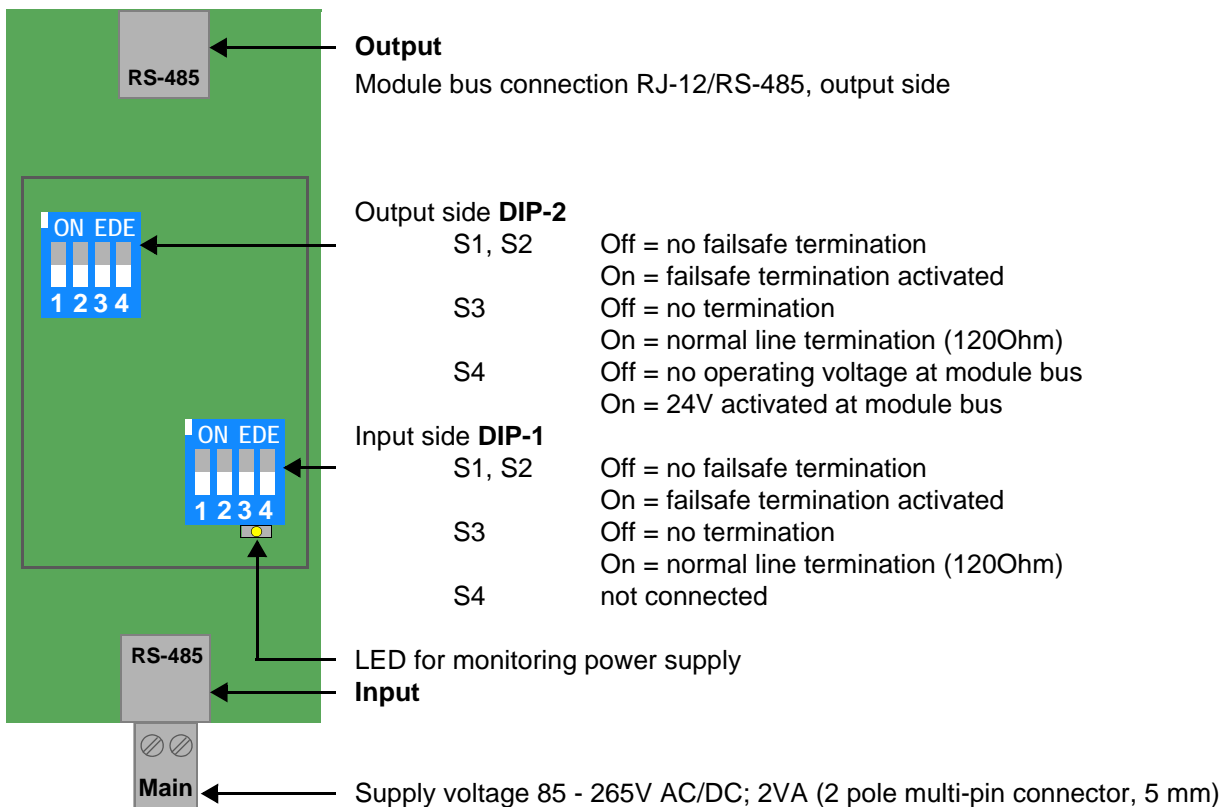

Note

The failsafe termination can only be actived once per bus segment!

When used as a voltage supply / module bus expansion, the terminating resistors at the input and output side have to be activated.

1.1.1 Module bus connection RJ-12/RS-485

Terminal assignment:

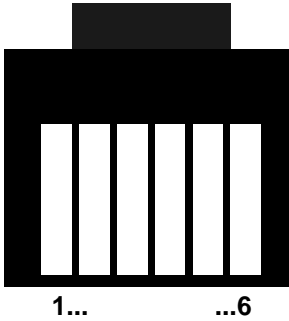

- Pin 1: ground
- Pin 2: ground
- Pin 3: RT+ (A (Bus RS-485))
- Pin 4: RT- (B (Bus RS-485))
- Pin 5: + 24 V
- Pin 6: + 24 V

1.2 Connection diagram

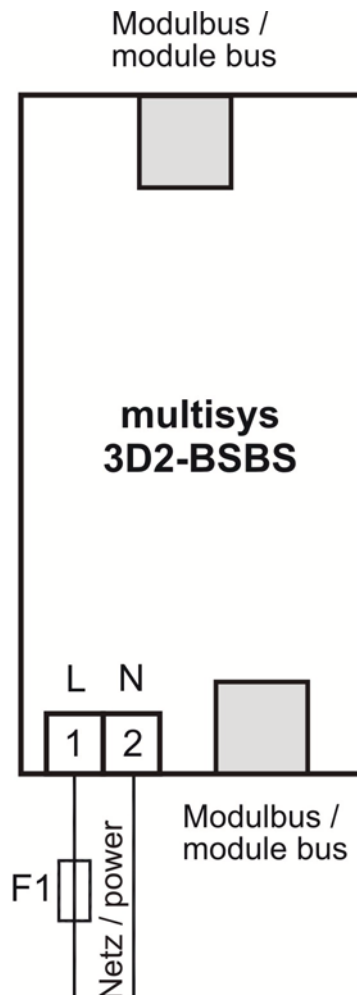

* For voltage supply, see nameplate.

2 Technical data

2.1 Power supply

Power supply	85 - 265V AC/DC ; 2VA
--------------	-----------------------

2.2 Electrical connection

Connection elements		Plug-in terminals
Permissible cross section of the connection lines		Power supply 2.5 mm ² , bus connection 1.5 mm ²
Input Control voltage	Fuse protection	max. 6 A
Module bus connection		Modular connector RJ-12: 6P6C
Module bus connection	Connection material	Modular 6 pole cable

2.3 Mechanical data

Top hat rail device	Housing measures	90 x 36 x 61 mm (H x W x D),
	Mounting type	Wall mounting on DIN rail 7.5 mm deep, in accordance with DIN EN 50022 Suitable for distribution board mounting
	Weight	approx. 120g

2.4 Standards and miscellaneous

Environmental conditions	Standards	DIN EN 60721-3-3/A2: 1997-07; 3K5+3Z11; (IEC721-3-3; 3K5+3Z11)
	Operating temperature	- 5°C+60°C
	Humidity	5%95%
	Storage temperature	-25°C+70°C
Electrical safety	Standards	DIN EN 61010-1/A2: 1996-05; (IEC1010-1/A2)
	Protection class	I, in accordance with DIN EN 61010-/A2: 1996-05
	Overvoltage category	CAT III: U _{PH-PH} up to 400V
	Mode of protection	IP20 in accordance with DIN EN 40050 Part 9: 1993-05
	Electromagnetic compatibility	DIN EN 61000-6-3: 2005-06; (IEC 61000-6-3) DIN EN 61000-6-2: 2006-03; (IEC 61000-6-2)

**ERKLÄRUNG DER KONFORMITÄT
DECLARATION OF CONFORMITY
DÉCLARATION DE CONFORMITÉ**

Wir **KBR GmbH Schwabach**

We/Nous (Name des Anbieters / supplier's name / nom du fournisseur)

**Am Kieferschlag 7
D-91126 Schwabach**

(Anschrift / address / adresse)

erklären in alleiniger Verantwortung, dass das (die) Produkt(e) /
declare under our sole responsibility that the product(s) / Déclarons sous notre seule responsabilité, que le(s) produit(s)

multisys 3D2-BSBS

(Bezeichnung, Typ oder Modell oder Seriennummer / name, type or model or serial number / nom, type ou modèle, N° de lot ou de série)

mit folgenden Europäischen Richtlinien übereinstimmt (übereinstimmen)
is (are) in conformity with the following directives / Répondet(ent) aux directives suivantes

Niederspannungsrichtlinie Nr.
Low Voltage Directive No.
Directive Basse Tension N°

EMV-Richtlinie Nr.
EMV Directive No.
EMV Directive N°

2006/95/EG
2006/95/EC
2006/95/CE

2004/108/EG
2004/108/EC
2004/108/CE

Dies wird nachgewiesen durch die Einhaltung folgender Norm(en)

This is documented by the accordance with the following standard(s) / Justifié par le respect de la (des) norme(s) suivante(s)

DIN EN 61010-1-2001;

DIN EN 61010-1/B1:2002

DIN EN 61010-1/B2:2004

DIN EN 61000-6-1:2007

DIN EN 61000-6-2:2005

DIN EN 61000-6-3:2007

DIN EN 61000-6-4:2007

(Titel und/oder Nr. sowie Ausgabedatum der Norm(en))

Title and/or number and date of issue of the standard(s)

Titre et/ou numéro et date d'édition de la (des) norme(s)



Schwabach, 18.07.2011

(Ort und Datum der Ausstellung)

Place and date of issue

Lieu et date de l'édition)



Geschäftsführer

General manager

An
KBR GmbH
 Abteilung Entwicklung
 Am Kiefernschlag 7
D-91126 Schwabach

To
KBR GmbH
 Development
 Am Kiefernschlag 7
D-91126 Schwabach / Germany

Vorschläge:
 Korrekturen:
 Betrifft Gerät:

Suggestions:
 Corrections:
 Device concerned

Sollten Sie beim Lesen dieser Bedienungsanleitung oder Druckschrift auf Druckfehler gestoßen sein, bitten wir Sie, uns diese mitzuteilen. Ebenso freuen wir uns natürlich über Anregungen, Hinweise oder Verbesserungsvorschläge.

If you come across misprints in this user manual or printed material, please take the time to notify us. We will also be glad to hear your ideas, notes and suggestions for improvement.

Bitte geben Sie die betreffende Anleitung oder Druckschrift mit Versionsnummer und/oder Ausgabestand an.

Please identify the user manual or printed material in question with version number and/or revision number.

Absender / Sender:

Name:

Firma/Dienststelle, / Copany/Department:

Anschrift / Address:

Telefon / Phone:

Telefax / Fax:

email:

Korrekturvorschläge zur Bedienungsanleitung / Druckschrift

Corrections/Suggestions for user manual / Printed material

Version
