

disperator® FOOD WASTE PROCESSOR

500A-GTS-E65 EXCELLENT SERIES

- Grinding and transportation of food waste to tank with the addition of minimal amounts of water
- Retains the energy content for decay and biogas production at a later stage
- Improved hygiene, working environment and ergonomics when working in a kitchen environment. The handling, storage and emptying of refuse containers is no longer necessary
- Rapid disposal of food waste with a high degree of reliability
- Easy to operate and clean
- Reduced need for transportation and lower costs for food waste collection
- Standard delivery includes the outer cabinet made of stainless steel AISI304. As option the outer cabinet are also available in acid proof stainless steel AISI316 for outdoor installation in sea water environments



Immediately and efficiently removing the heaviest part of kitchen waste – food leftovers – is a necessity in any commercial kitchen. When using the patent pending GTS-Series processor, food waste can hygienically and without any heavy lifting or manual transfer easily take care of and reduce the total amount of refuse – by volume, but above all by weight!

Food waste is fed into the inlet hopper of the machine and ground into small particles for further transport in a pipe using a unique processor pump to a sealed and odorless tank, and when full, emptied by a vacuum truck. The unique benefit of this processor technology is that the pumping of the ground food waste can be done with minimal amount of flushing water, which gives a good operating economy as the tank does not need to be emptied as often. The slurry is transported to an anaerobic digestion facility and converted into valuable renewable energy resource (i.e. biogas), and often the digested residue can also be used as fertilizer on farmland. Biogas is one of our society's most environmentally clean and desired energy forms, as fuel for cars as well as for the production of heat and electricity.

To suit existing interior and logistics within the kitchen, the processor outlet may be positioned either to the left or to the right of the infeed opening, thus giving full flexibility in planning your kitchen and possibility to fully utilize valuable space. Disperator's broad assortment of different technical solutions for source separation of food waste can be adapted to your specific kitchen and your specific working environment, regardless of size or layout, and regardless of the specific food waste handling rules in your environment!

Disperator GTS-Series processor fulfills the relevant provisions of the Machinery Directive 2006/42/EC, Low Voltage Directive 2014/35/EU and the EMC Directive 2014/30/EU.

All Disperator Excellent GTS-Series of processors have the Statement of Compliance issued by DNV GL verifying compliance with applicable sections of MARPOL Annex V REGULATIONS FOR THE CONTROL OF POLLUTION BY GARBAGE FROM SHIPS AND PLATFORMS, as amended in 2019.

Disperator AB

Mälarvägen 9, SE-141 71 Segeltorp, Sweden
Tel +46-8-724 01 60
info@disperator.se, www.disperator.se



MADE IN SWEDEN

disperator® FOOD WASTE PROCESSOR

500A-GTS-E65 EXCELLENT SERIES

Front view

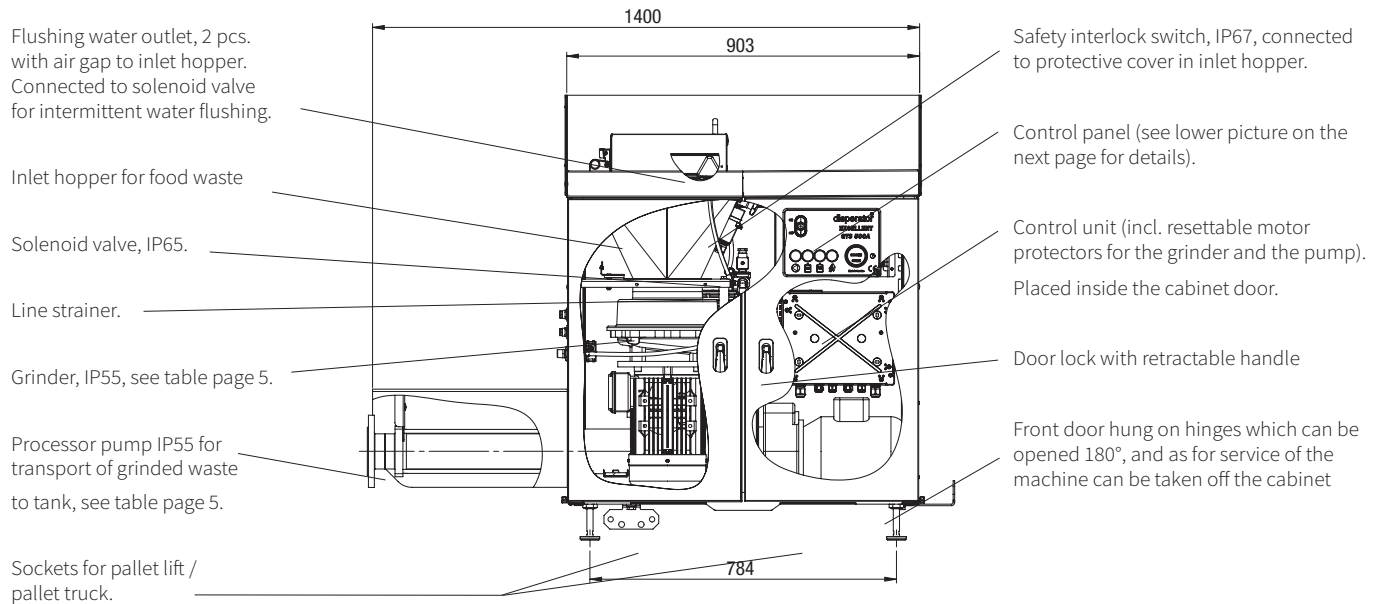

Side view

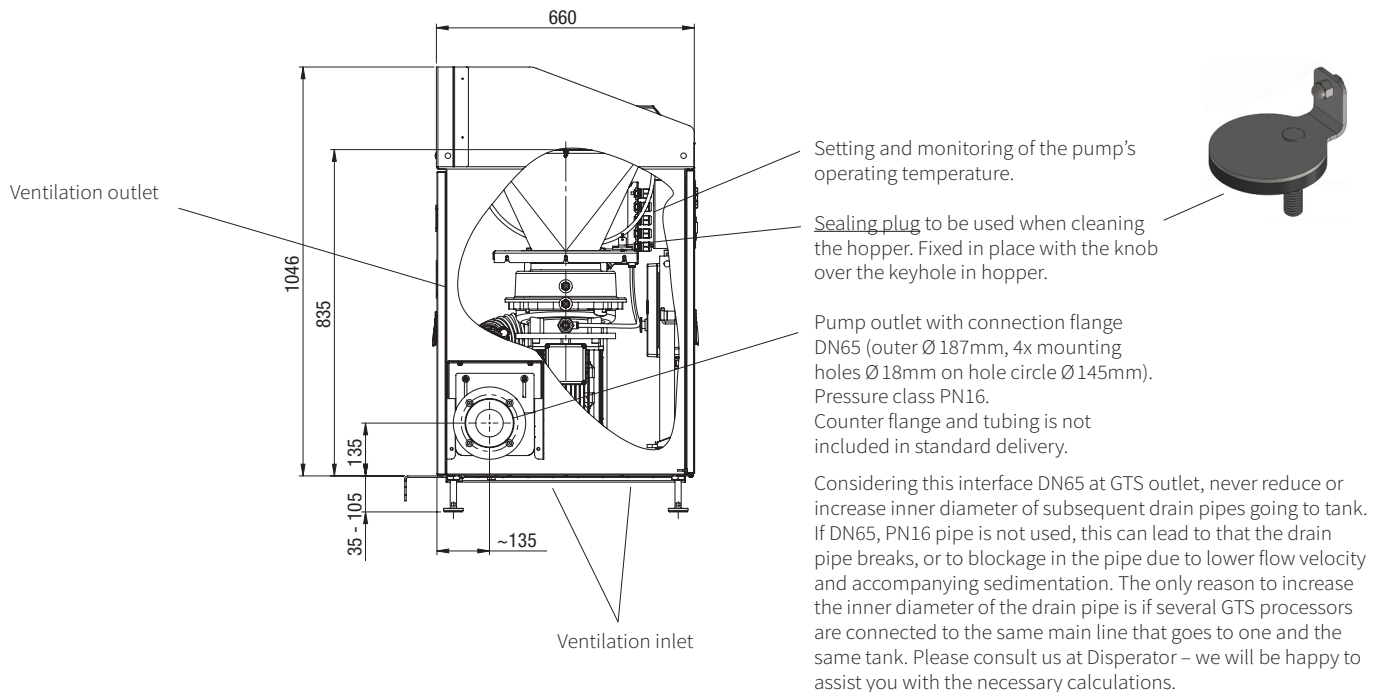

All dimensions in mm

Disperator AB

Mälurvägen 9, SE-141 71 Segeltorp, Sweden
 Tel +46-8-724 01 60
 info@disperator.se, www.disperator.se

Ref: 500A_GTS-E65_pb_en_211019

disperator® FOOD WASTE PROCESSOR

500A-GTS-E65 EXCELLENT SERIES

Top view

Cabinet rear panel (removable for service of the machine).

Adjustable bracket. 2 pcs. for fixing the machine against a long wall, or alternatively using 1 pc. against a long wall and 1pc. against a corner wall.

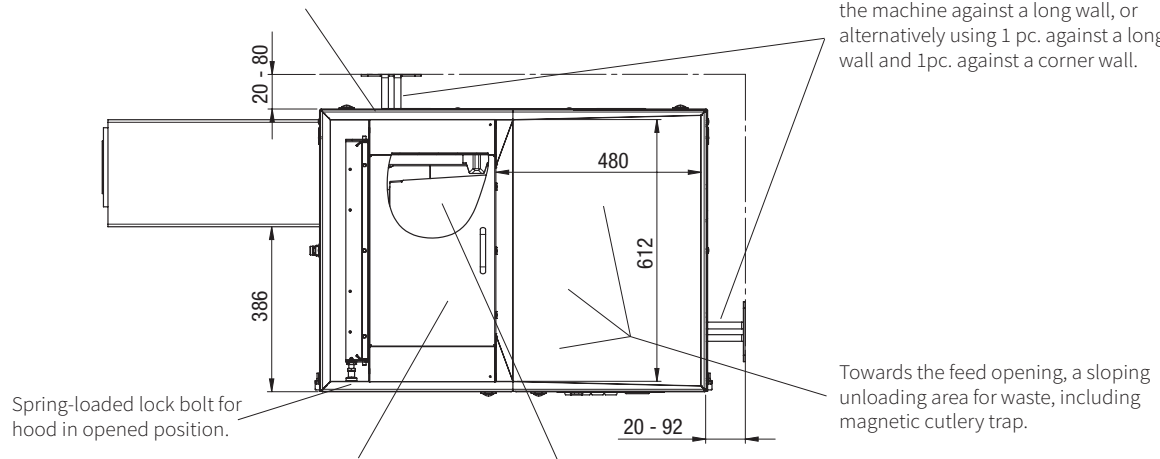

Noise absorbing hood above feed opening. (Can be opened for batch emptying of receptacles with e.g. soup, sauce, etc.)

Protective cover in the feeding hopper to the disposer, linked to safety interlock switch. Removed during daily cleaning. The machine will then not start until the cover is back in place.

Top view of foot

Marine version

Land version

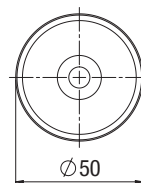
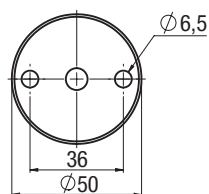

All dimensions in mm

Disperator AB

Mälarvägen 9, SE-141 71 Segeltorp, Sweden
Tel +46-8-724 01 60
info@disperator.se, www.disperator.se

Ref: 500A_GTS-E65_pb_en_211019

disperator® FOOD WASTE PROCESSOR

500A-GTS-E65 EXCELLENT SERIES

Splash guard (to be installed on site). If left or right guard is not desired, this can be left out.

Cable gland for the signal cable from the level sensors in the tank.

Cable gland and 2m cable for connection via safety switch to fuse cabinet (but without connection to earth leakage circuit breaker).

Connection R $\frac{1}{2}$ " (BSPT), external thread for cold flushing water. Hot water is not necessary.

User manual and jam release wrench for the grinding unit are placed on the inside of the left door.

In height adjustable legs with rubber coated feet Ø50mm, alternatively feet Ø50mm for welding or bolting in marine floorboard.

Machine start and stop buttons.



Yellow button (spring loaded) for machine emptying:
• after cleaning,
• after batch of liquid waste,
• when servicing the pump.

Blue button (spring loaded) for extra flushing water for dry food waste and also for emptying the piping from waste before longer operating breaks in the kitchen.

Digital running time gauge.

Red lamp lights up = tank is full, the machine cannot be started until the tank is emptied.

Yellow lamp lights up = order emptying of tank.

All dimensions in mm

Disperator AB

Mälarvägen 9, SE-141 71 Segeltorp, Sweden
Tel +46-8-724 01 60
info@disperator.se, www.disperator.se

Ref: 500A_GTS-E65_pb_en_211019

disperator® FOOD WASTE PROCESSOR

500A-GTS-E65 EXCELLENT SERIES

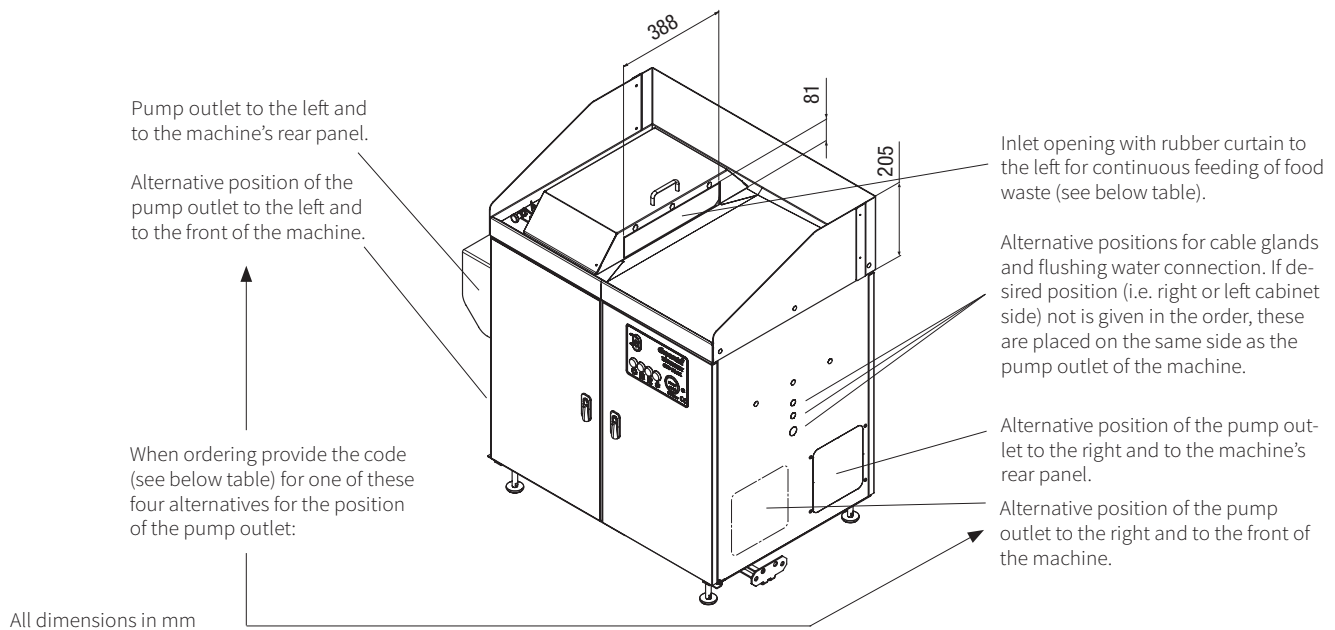

Alternative	Position of the inlet opening for waste	Position of the pump outlet	Provide the following code when ordering
1 (the alternative shown in the above picture)	to the left	to the left and to the machine's rear panel	VVB
2	to the left	to the left and to the front of the machine	VVF
3	to the left	to the right and to the machine's rear panel	VHB
4	to the left	to the right and to the front of the machine	VHF
5	to the right	to the left and to the machine's rear panel	HVB
6	to the right	to the left and to the front of the machine	HVF
7	to the right	to the right and to the machine rear panel	HHB
8	to the right	to the right and to the front of the machine	HHF

Disperator AB

Mälarvägen 9, SE-141 71 Segeltorp, Sweden
 Tel +46-8-724 01 60
 info@disperator.se, www.disperator.se

Ref: 500A_GTS-E65_pb_en_211019

disperator® FOOD WASTE PROCESSOR

500A-GTS-E65 EXCELLENT SERIES

The below picture show example of electro-welded plastic pipes, DN65 for connection of the food waste processor outlet, DN65 to drain pipe, DN65 which comes out of the floor. If welded acid proof stainless steel (EN1.4401, AISI316) drainage pipes, DN65 are chosen instead, the pipe does not have to be shaped in a lyre (as on these images) for height wise fit over the floor - but can be directed straight towards the pipe connection in the floor. Note that all drain pipe details must have pressure class PN16, and also note that no such pipe details are included in the standard delivery of the machine. For detailed information about these pipes (make, article number etc.) contact DISPERATOR.

Picture No. 1:
Version VVB and HVB
(see table on page 5)

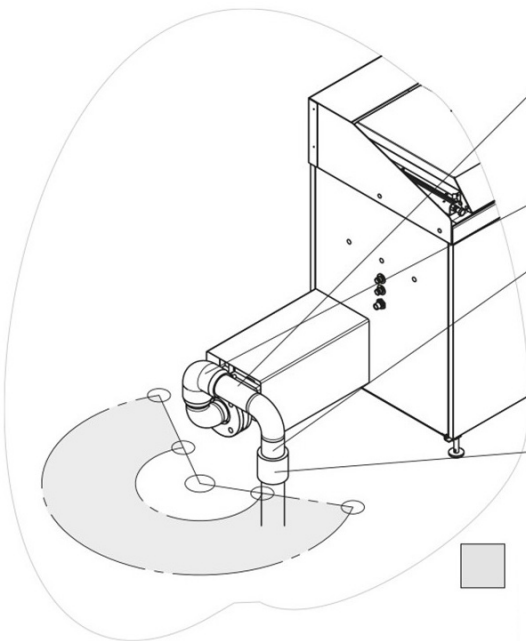

**) The horizontal part that has been welded to the pipe bend is cut to the correct length on site during installation, and then welded into the electric weld socket (see below). Other pipe details on the picture can be welded in advance at the factory.

Electrical weld socket, which is welded in place during installation.

On site during installation, the length of the vertical part that has been welded to the pipe bend (approx. 47-116mm) is adjusted to the chosen adjustable machine height above the floor, and then connected by means of the STRAUB-coupling to the drain pipe socket in the floor.

Coupling (e.g. STRAUB type) to easily open and clean the drain pipe if necessary.

With the horizontal pipe that has been welded to the pipe bend (see ** above) cut to between min. 80mm and max. 382mm, the center of the drain pipe can get out of the floor in this area. If the maximum length of the horizontal tube increase, the area can be expanded

Picture No. 2:
Version VVF and HVF
(see table on page 5)

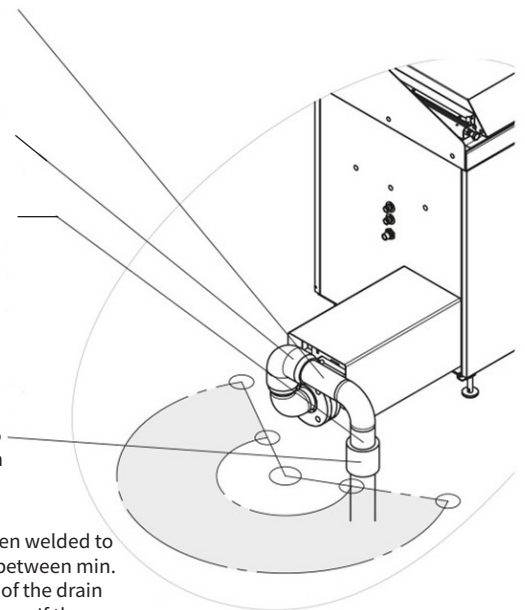

Space for the machine drain pipe under other manufacturer's bench must be for all of the below dimensions

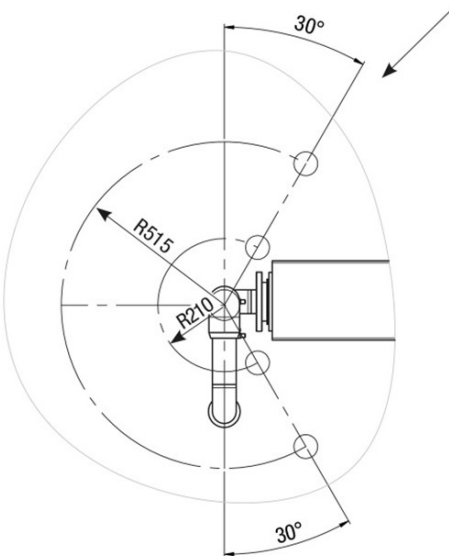

All measurements in mm

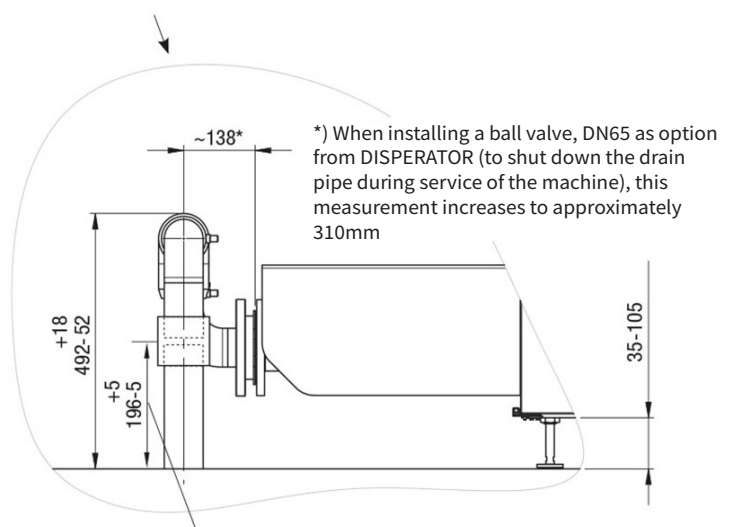

Height above floor of drainage pipe coming out if the floor

*) When installing a ball valve, DN65 as option from DISPERATOR (to shut down the drain pipe during service of the machine), this measurement increases to approximately 310mm

Disperator AB

Mälarvägen 9, SE-141 71 Segeltorp, Sweden
Tel +46-8-724 01 60
info@disperator.se, www.disperator.se

disperator® FOOD WASTE PROCESSOR

500A-GTS-E65 EXCELLENT SERIES

The below picture show example of electro-welded plastic pipes, DN65 for connection of the food waste processor outlet, DN65 to drain pipe, DN65 which comes out of the floor. If welded acid proof stainless steel (EN1.4401, AISI316) drainage pipes, DN65 are chosen instead, the pipe does not have to be shaped in a lyre (as on these images) for height wise fit over the floor - but can be directed straight towards the pipe connection in the floor. Note that all drain pipe details must have pressure class PN16, and also note that no such pipe details are included in the standard delivery of the machine. For detailed information about these pipes (make, article number etc.) contact DISPERATOR.

Picture No. 3:
Version VHB and HHB
(see table on page 5)

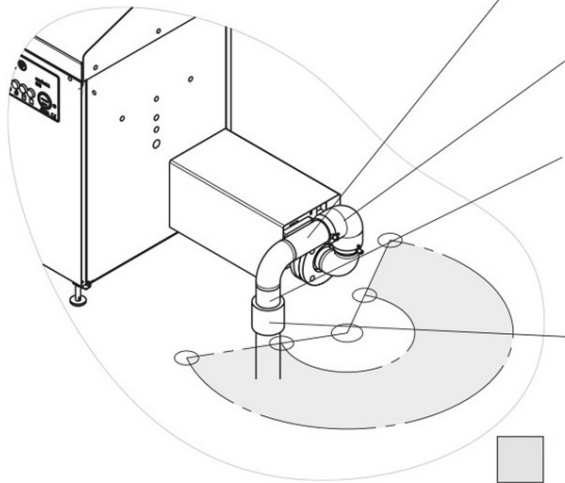

** The horizontal part that has been welded to the pipe bend is cut to the correct length on site during installation, and then welded into the electric weld socket (see below). Other pipe details on the picture can be welded in advance at the factory.

Electrical weld socket, which is welded in place during installation.

On site during installation, the length of the vertical part that has been welded to the pipe bend (approx. 47-116mm) is adjusted to the chosen adjustable machine height above the floor, and then connected by means of the STRAUB-coupling to the drain pipe socket in the floor.

Coupling (e.g. STRAUB type) to easily open and clean the drain pipe if necessary.

With the horizontal pipe that has been welded to the pipe bend (see ** above) cut to between min. 80mm and max. 382mm, the center of the drain pipe can get out of the floor in this area. If the maximum length of the horizontal tube increase, the area can be expanded

Picture No. 4:
Version VHF and HHF
(see table on page 5)

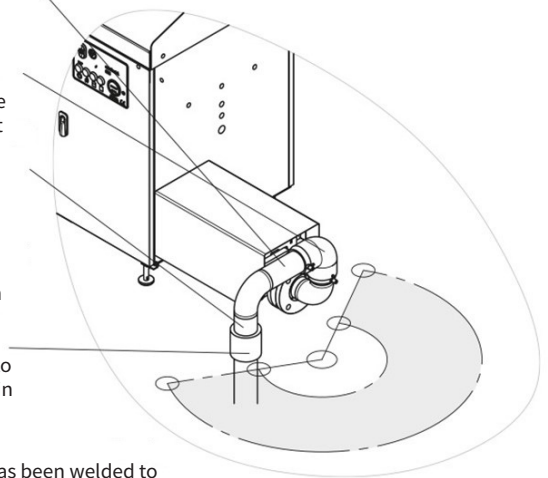

Space for the machine drain pipe under other manufacturer's bench must be for all of the below dimensions

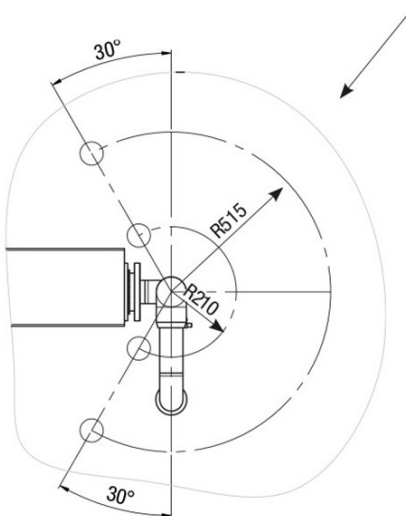

All measurements in mm

*) When installing a ball valve, DN65 as option from DISPERATOR (to shut down the drain pipe during service of the machine), this measurement increases to approximately 310mm

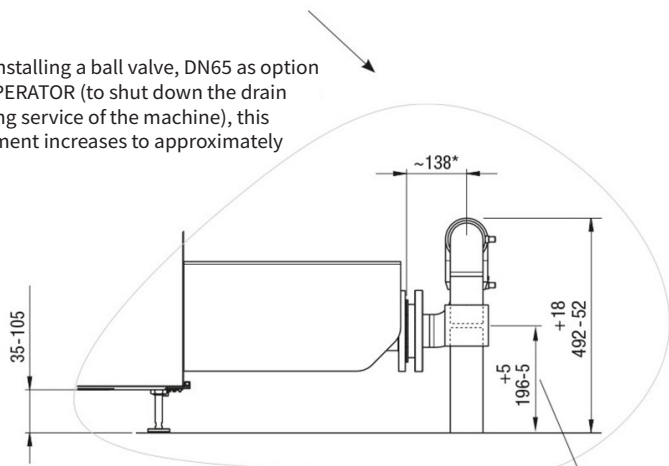

Height above floor of drainage pipe coming out if the floor

Disperator AB

Mälarvägen 9, SE-141 71 Segeltorp, Sweden
Tel +46-8-724 01 60
info@disperator.se, www.disperator.se

disperator® FOOD WASTE PROCESSOR

500A-GTS-E65 EXCELLENT SERIES

Technical specification	530A-GTS-E65	550A-GTS-E65	575A-GTS-E65
Standard capacity, liters/hr.	600	750	900
Optional capacity, liters/hr.	1400	1600	1800
Electrical power, kW (disposer+pump)	2,5+1,5	4,0+1,5	5,5+1,5
Rated current, A to be set on the two processor motor protectors for the following voltages:			
400V / 3 ph. / 50 Hz (disposer+pump)	9,1 (5,5+3,6)	12,2 (8,6+3,6)	15,1 (11,5+3,6)
440V / 3 ph. / 60 Hz (disposer+pump)	9,1 (5,5+3,6)	11,1 (7,5+3,6)	13,6 (10,0+3,6)
Control voltage	230V 50/60Hz	230V 50/60Hz	230V 50/60Hz
Fuse rating, slow	16A	16A	16A
Characteristic for automatic fuse	D (slow)	D (slow)	D (slow)
Net weight, kg	210	215	230
Processor drainage outlet	DN65	DN65	DN65
<i>Process pump pressure class:</i>			
*standard	PN16	PN16	PN16
*optional	PN10	PN10	PN10

The processor operates in the temperature range -5°C to +40°C

Note1: Connect the machine via safety switch to fuse cabinet, but without connection to earth leakage circuit breaker.

Subject to any changes without prior notice.

(1) Installation material needed but not incl. in standard delivery are:

- main electrical safety switch placed on wall/bulkhead for incoming electricity, see note 1,
- hose with protective steel-covered stocking (minimum inner -Ø 9mm) for cold flush water,
- vacuum valve for flushing water pipe when flushing nozzle in hopper is used. Can be ordered from DISPERATOR.

(2) User manual with installation and service instructions, laminated operating instructions and laminated safety instructions as well as electrical documentation are included in delivery.

(3) Options:

- DN65 drain valve,
- equipment for monitoring of tank level,
- waste holding tanks for indoor installation,
- waste holding tanks for installation below ground level outdoors,
- drain pipe with pressure class PN16 in plastic or stainless steel between the processor and the tank
- DN65 backflow preventer.

Disperator AB

Mälarvägen 9, SE-141 71 Segeltorp, Sweden
Tel +46-8-724 01 60
info@disperator.se, www.disperator.se

Ref: 500A_GTS-E65_pb_en_211019