



Use

Vane anemometers are used for the velocity measurement of directed air flows being free from eddies and turbulences. Because of the small, sturdy construction the instrument is suitable for mobile or stationary use. For example the measurement in the free jet, at fresh air inlets and suction openings, in ducts and conduits.

Contrary to flow measurements with Pitot static meters, the measurements with the vane anemometer are largely independent of the respective air density. Vane anemometers have the advantage that the measuring results do not need to be corrected in a wide limit even if the temperature fluctuates or the pressure changes.



Note!

Vane anemometers are precision mechanical instruments. They should be protected against moisture, contamination and shocks.

Function

The measuring element of the vane anemometer consists of ten light pressure plates radial equally arranged as ring in-plane - so called vane wheel. The vane wheel is very light and has in the center of the ring vertical to the circle plane a rotational axis.

All ten pressure plates (vanes) are arranged in the same direction in a certain angle to the rotation axis so that any flow running in the direction of the axis exerts on the measuring element a torsional moment acting always in the same direction, so that the system running (on miniature bearings). The number of revolutions is practically proportional to the velocity of the flow from initial direction.

Versions

To fulfil the different requirements, the rotation of the vane anemometer is determined with different measuring elements.

1468 Id.-No. 00.14680.020 400

Vane Anemometer with DC-generator
Output: $0 \dots 4 \text{ mA} = 0 \dots 20 \text{ m/s}$
($R_a = 105 \Omega$)
Current line: $v = 4.9 I + 0.4$

1468 I 507 Id.-No. 00.14683.015 070

Vane Anemometer with inductive taps acc. to NAMUR
(DIN 19 234)
Output: $300 \text{ Hz} \pm 6 \text{ Hz}$ at 10 m/s
Power supply: 8 VDC

1468 S9 Id.-No. 00.14689.005 020

Vane Anemometer with 2 inductive taps acc. to NAMUR
(DIN 19 234) for directional air flows.

1468

Vane Anemometer with DC-generator

With this version the vane wheel shaft is coupled with the rotor of the DC-generator. The generator is constructed as light, ironless bell type armature with self-supporting armature coil. It is low in inertia and follows all changes of the vane wheel revolutions free of slowing down.

The rotor rotates in the permanent field of an internal core magnet system. The measuring voltage induced in the windings of the rotor increases steadily with the vane wheel's number of revolutions and thus also with the flow velocity. Via a completely corrosion-proof metal collector the measuring voltage is led off and transmitted to the indicator instrument, e.g. an ammeter.

The essential feature of the vane anemometer with DC-generator is turned out by, on the one hand because of the low power requirement, on the other hand because of the linear depending of the generator current to the number of revolutions, the linear relationship between the current output and the flow velocity. Over the whole measuring range the correlation between current and flow velocity is linear.

Technical Data

Measuring range: 0...20 m/s
 Starting value: approx. 0.5 m/s
 Operating temperature range: -30...+60 °C
 Output: 4 mA at 20 m/s and $R_a = 105 \Omega$
 $v = 4.9 I + 0.4$
 Current line:
 Cable length: 3 m

Electrical connection

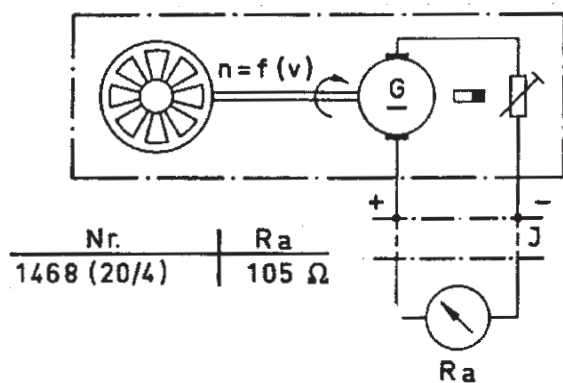

1468 I 507

Vane Anemometer with inductive taps

With this model the vane wheel axis is connect with a segmented disc. During rotation every segment passage delivers an impulse, which is determined with an inductive tap acc. to NAMUR (DIN 19 234). These impulses are amplified and transmitted over 2 wires.

This measuring element has a low friction and a particular low starting value.

Technical Data

Measuring range: 0...20 m/s
 Starting value: approx. 0,1 m/s
 Operating temperature range: -25...+100 °C
 Output: 300 Hz ± 6 Hz at 10 m/s
 Power supply: 8 VDC
 Load: approx. 1 kΩ
 Cable length: 3 m

Geschwindigkeit / Velocity	Frequenz / Frequency
5 m/s	149 Hz
6 m/s	179 Hz
10 m/s	300 Hz
20 m/s	603 Hz

Electrical Connection

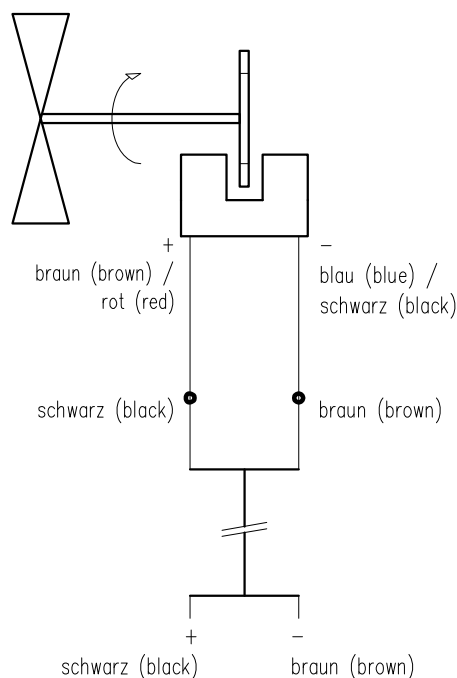

1468 S9
Vane Anemometer with 2 inductive taps

Also with this model the vane wheel axis is connect with a segmented disc, but the number of revolution of the vane wheel is determined with two inductive taps acc. to NAMUR (DIN 19 234). Therefore in conjunction with the direction monitoring unit it is possible to recognize different flow directions.

Technical Data

Measuring range:	0...20 m/s
Starting value:	approx. 0.1 m/s
Operating temperature range:	-30...+60 °C
Output:	2 x 170 Hz ± 4 Hz at 20 m/s
Power supply:	8 V DC
Load:	approx. 1 kΩ
Cable length:	3 m

Geschwindigkeit/Velocity	Frequenz/Frequency
5 m/s	43 Hz
6 m/s	52 Hz
10 m/s	86 Hz
20 m/s	172 Hz

Electrical Connection

Example SWF 2427e: Vane Anemometer 1468 S9 with direction monitoring unit and digital-analog-converter

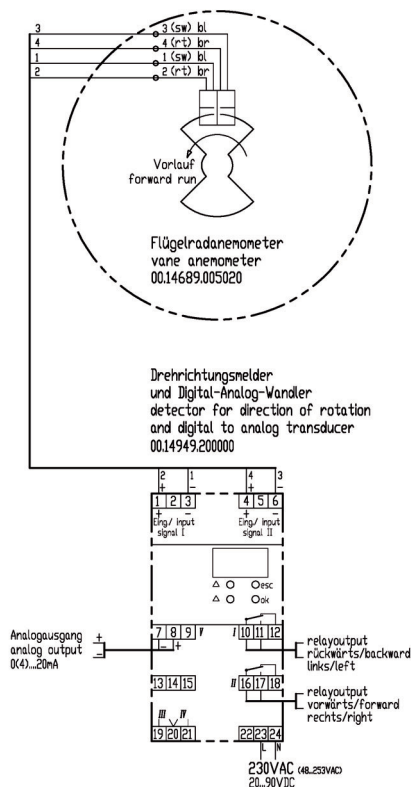

Planning help
for the vane anemometer 1468
with inductive taps

The DIN 19 234 (NAMUR)

The DIN 19 234 describes the technical data of the interface between proximity switch acc. to NAMUR (general named: electronical position sensor) and an electronical amplifier. The power supply and the impulses are transmitted over 2 wires. The amplifier is controlled by the variable current consumption of the proximity switch. For the best act in combination between proximity switch and amplifier the DIN 19 234 lay down the following values for the amplifier:

1. Current consumption for the current circle
 - Open circuit voltage U_0 : 7...9 V
 - Preferred value: 8.2 V
 - Short circuit current I_k : 7...16 mA
 - Preferred value: 8.2 mA
 2. Current dependent break over resp. control points
 - 2a. Break over point

The break over point of the amplifier must be inside the current consumption range of the proximity switch of about 1.2 mA to 2.1 mA.
 - 2b. Line break control

If the current consumption of the proximity switch falls below a certain value, a line break error or a corresponding error is assumed. The line break control must be inside the current area of 0.05 mA to 0.15 mA.
 - 2c. Line short circuit control

Exceeds the current consumption of the proximity switch a certain value, a line short circuit or a corresponding error is assumed. The line short circuit control must be inside the current area, which corresponds to a resistor of the proximity switch of 360 to 1000 ohms. With a preferred power supply acc. point 1, this is a current area of 6.0 to 7.45 mA.
- Because of this data acc. DIN 19 234, the release of the switch resp. control processes is decisive from the current in the interface between proximity switch and amplifier. The line resistance should be less than 100 ohms.

Choice of the measuring place

In any case, a basic condition for perfect measuring results is a directed, unrifled and irrational air flow at the measuring site (see DIN 1946 „VDI-Lüftungs-Regeln = VDI Ventilation Rules“).

In general such air flow conditions prevail in closed ducts having an undisturbed steadying length of $6 \times D$ (D = inside diameter of the conduit respectively equivalent diameter in case of rectangular ducts) before and $4 \times D$ behind the measuring point without sudden changes of cross section and without elbows or shut-off devices.

A steadying length of $40 \times D$ is required for measurements behind elbows. By means of suitable arranged baffles it is possible to reduce also in this case the inlet section to approx. $6 \times D$.

In case of turbulent and twisted air flow, a straightener has to be installed at a distance of approx. $1 \times D$ in front of the anemometer. This straightener can easily be assembled from a number of thin-walled tubes which should have a diameter of approx. $1/10 D$ and a length of approx. $3/10 D$. They should be installed axially into the pipe line and should completely fill the flow cross section.

When taking measurements in conduits of less than 500 mm diameter (approx. 0.2 m^2), the reduction of the cross section due to the installation of the anemometer becomes effective and there will be indicated too high velocity values.

Measurements taken in front of the air intakes and behind induction openings often have their difficulties as the velocity outside the duct decreases very quickly with the distance from the inlet. The jet cross section increases and the direction of the air flow changes simultaneously. If local conditions allow, we recommend to attach a duct piece with the same cross section at such openings and to measure the velocity within this extension. The length of the duct piece should be determined taking into consideration the above mentioned steadying lengths. It is advisable to reduce the cross section for the purpose of shortening the extension piece, otherwise losses of pressure will occur which falsify the measuring results. Correct measuring results can be obtained within the free jet without an extension of the duct in case of large air passage at low velocity.

Measurement

In case of mobile use, an optional available handle can be screwed onto the anemometer. The handle is fastened by means of the centric M8 female thread in the base plate or of the two M5 female threads arranged on the left and right side of the M8 thread.

By using the same threads, a stationary mounting of the anemometers is possible. Before doing so it is necessary to measure the velocity profile (see later). Hereafter the instrument can be fastened at a site with mean velocity. Consequently, the anemometer is not always arranged centrally in the measuring cross section.

Vane anemometer operates independent of the position, but not independent of the flow direction. In general, they have to be held or installed in such a way that the flow reaches the vane wheel in the direction of the arrow arranged on the protective ring. Deviations up to a maximum of 10° are permissible.

In principle it is possible to sense also return flows. In this case the polarity of the output current remains the same. If return flows shall not be sensed, a direction discriminator has additionally to be used as indicator for the direction of rotation.

Mobile measurement

In case of mobile measurements it is recommended to set the vane wheel running by blowing against it before holding it into the flow thus avoiding a too strong pulsating load.

Taking the mean

In general, the air flow velocity is not equal at all points of a duct cross section or air passage. In order to obtain exact measuring results in large cross sections it is therefore necessary to carry out a series of individual measurements the mean of which represents the actual flow velocity. Different procedures can be used in order to effect these measurements.

Grid Method

The cross section redivided into the largest possible number of equal areas and one measurement is taken in the center of each such area. The mean value of all measurements is the average velocity which is decisive for the determination of the quantity of flow. The quantity of flow can also be ascertained - particularly in case of partially covered passages - by multiplying each measured velocity value with the relevant cross sections. The sum of all individual measurements thus obtained represents the quantity of flow.

Line of gravity method

In a duct with circular cross section it is recommended to take measurements in two diameters standing vertically to each other in order to determine the mean velocity. The results are plotted graphically in relation to the diameter and the velocity profiles are plotted accordingly. The diameter should be subdivided into 5 or 10 circular rings of equal area. Now the velocities corresponding to the circles of the center of gravity of these ring areas (including the circle of the center of gravity of the central circular area) can be taken from the graph. Their arithmetic mean represents the mean velocity.

The mean velocity multiplied with the inside cross section of the duct is the quantity of air flow. The graphical representation is not required if the measurements are taken in the circles of the center of gravity.

The following table shows the radii of the center of gravity when dividing a circular cross section with the radius $r = 1$ into $n = 5$ rings (10 measuring points across the diameter) or $n = 10$ rings (20 measuring points across the diameter). The radii of the circles of the center of gravity which have to be considered when carrying out the measurement, are obtained by multiplying the gravity point radii with the actual radius of the duct.

Schwerpunktradien Radii of the center of gravity										
n	n ₁	n ₂	n ₃	n ₄	n ₅	n ₆	n ₇	n ₈	n ₉	n ₁₀
5	0.95	0.84	0.71	0.55	0.32					
10	0.97	0.92	0.87	0.81	0.75	0.67	0.59	0.50	0.39	0.22

n = number of circular rings of equal areas

If measurements are carried out in ducts with square or rectangular cross section it is, in general, sufficient to determine only the velocity profiles of the two symmetrical axes which are perpendicular to each other and to determine their arithmetic mean as a measure of the mean velocity.

Loop measurement

In case of very wide ducts, tunnels or pits, the loop measurement will give completely satisfactory results. For this purpose, the instrument should be moved during the measuring period in serpentine or large loops having the shape of a figure 8 across the measuring cross section.

Correction in case of small measuring cross section

Vane anemometers are balanced in such a way that the named output signal is correct in such cases when the measuring value transmitters are used in a relatively large measuring cross section. When taking measurements in closed conduits of less than 500 mm. inside diameter (surface of cross section approx. 0.2 mm the reduction of the cross section due to the installation of the instrument becomes effective and there will be measured more or less too high flow velocities depending on the diameter of the tube. The actual velocity v_{tats} can then be determined from read velocity v_a , clear cross-section of the tube F_R and the ideal cross section of the anemometer F_i by referring to the following formula:

$$v_{tats} = \frac{(F_R - F_i)}{F_R} * v_a$$

v_{tats} = actual velocity

v_a = measured velocity

F_R = clear cross-section of the tube

F_i = ideal cross section of the anemometer

The anemometer has an ideal cross section $F_i = 2795 \text{ mm}^2$, if the inside diameter of tube is larger than 109 mm.

If the inner tube diameter and the inner protection ring diameter of the anemometer are 105 mm, the ideal cross-section is $F_i = 2124 \text{ mm}^2$.

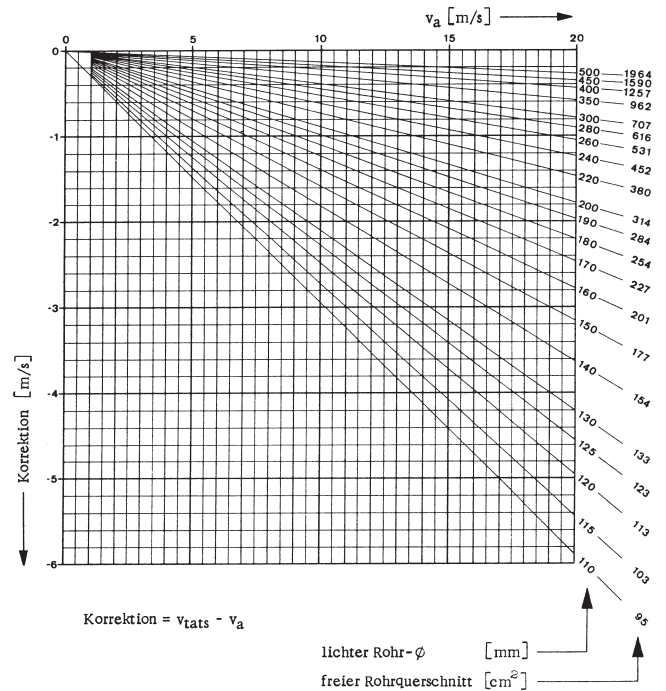

Maintenance

The vane wheel is made of a hard light metal alloy and therefore it is largely insensitive to mechanical influences. It should, however, be taken into consideration that any forceful bending of the vanes influences the original adjustment.

A cleaning of the surface of the anemometer should be carried out in dependence on the degree of contamination of the air to be tested and the frequency of use. A cleaning and lubrication of the ball bearings of the vane wheel should not be carried out anytime by yourself, because the running qualities should be very influenced (in the extreme case, the anemometer could be destroyed).

If a significant change of the running qualities is detected, the instrument should be sent to LAMBRECHT meteo for servicing.

Dimensional drawing

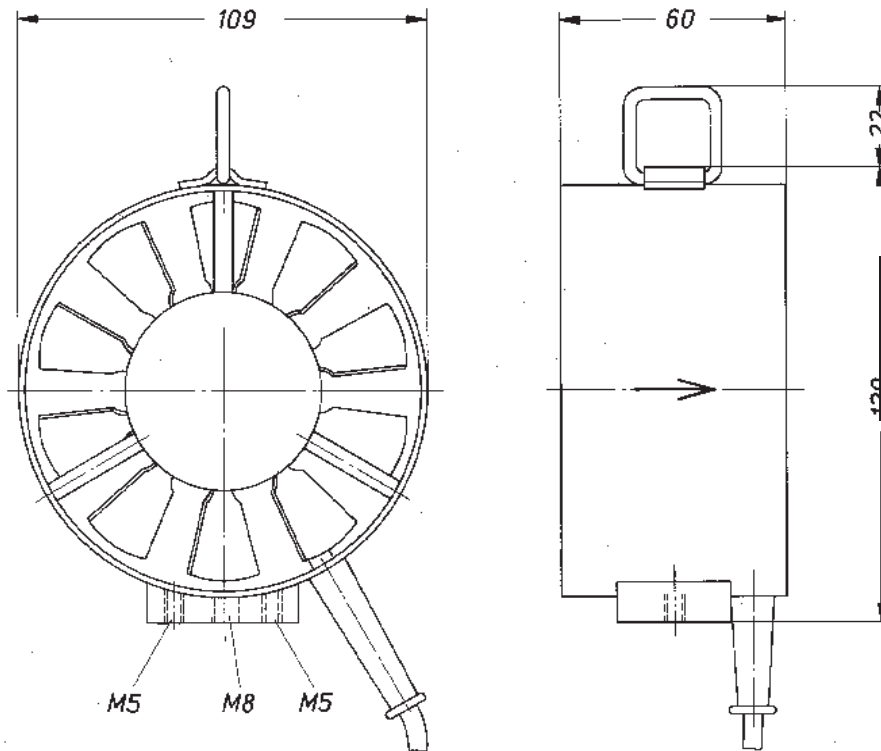

Please note the loss of warranty and non-liability by unauthorised manipulation of the system. You need a written permission from LAMBRECHT meteo GmbH for changes of system components. These activities must be operated by a qualified technician.

The warranty does not cover:

1. Mechanical damages caused by external impacts (e. g. icefall, rockfall, vandalism).
2. Impacts or damages caused by over-voltages or electromagnetic fields which are beyond the standards and specifications in the technical data.
3. Damages caused by improper handling, e. g. by wrong tools, incorrect installation, incorrect electrical installation (false polarity) etc.
4. Damages which are caused by using the device beyond the specified operation conditions.



Quality System certified by DQS according to
DIN EN ISO 9001:2015 Reg. No. 003748 QM15

Subject to change without notice.

14680_b-de.indd

35.20

LAMBRECHT meteo GmbH
Friedländer Weg 65-67
37085 Göttingen
Germany

Tel +49-(0)551-4958-0
Fax +49-(0)551-4958-312
E-Mail info@lambrecht.net
Internet www.lambrecht.net