



# LaserGuard Mini

---

## Laser Collision Avoidance System



**MAGNETEK**  
MATERIAL HANDLING

April 2020  
Part Number: 147-20127 R0  
© Copyright 2020 Magnetek

# Table of Contents

<b>1. LaserGuard Mini System Information .....</b>	<b>7</b>
1.1. Model Numbers .....	7
1.2. Class 1 Laser Sensor .....	7
1.3. System Description .....	7
1.4. System Specifications .....	8
1.5. Laser Support Unit Assemblies .....	9
<b>2. Electrical Installation .....</b>	<b>11</b>
2.1. Voltage Considerations .....	11
2.2. Wiring Considerations .....	11
2.3. Wiring Instructions.....	11
2.4. Laser Cable and Relay Wiring .....	12
2.5. Wiring Example .....	13
<b>3. Mechanical Installation .....</b>	<b>14</b>
3.1. Mounting Location Considerations.....	14
3.2. Laser Dimensions .....	14
3.3. Mechanical Installation and Alignment.....	15
3.4. Electrical Conduit Installation .....	23
<b>4. Functional Installation .....</b>	<b>24</b>
4.1. Laser Distance Set-Point Adjustment .....	24
4.2. Troubleshooting .....	25

# SERVICE INFORMATION

## U.S. Service Information:

For questions regarding service or technical information contact:

**Telephone:** 1-866-MAG-SERV (1-866-624-7378)

**E-mail:** field.service@magnetek.com

International Service (outside of U.S. & Canada):

**Telephone:** 262-783-3500

## World Headquarters:

Magnetek, Inc.  
N49 W13650 Campbell Drive  
Menomonee Falls, WI 53051

**Telephone:** 800-288-8178

**Website:** www.magnetek.com

### Fax Numbers:

Main: 800-298-3503

Sales: 262-783-3510

Service: 262-783-3508

## Canada Service Information:

161 Orenda Road

Unit 1

Brampton, Ontario

L6W 1W3 Canada

Telephone: 800-792-7253

Fax: 905-828-5707

## European Union Service Information:

Magnetek (UK) Ltd.

Unit 3 Bedford Business Centre

Mile Road

Bedford, MK42 9TW

Telephone: +44-1234-349191

Fax: +44-1234-268955

© 2020 MAGNETEK

All rights reserved. This notice applies to all copyrighted materials included with this product, including, but not limited to, this manual and software embodied within the product. This manual is intended for the sole use of the person(s) to whom it was provided, and any unauthorized distribution of the manual or dispersal of its contents is strictly forbidden. This manual may not be reproduced in whole or in part by any means whatsoever without the expressed written permission of MAGNETEK.

# PREFACE AND SAFETY

Magnetek, Inc. (Magnetek) offers a broad range of radio remote control products, control products, adjustable frequency drives, and industrial braking systems for material handling applications. This manual has been prepared by Magnetek to provide information and recommendations for the installation, use, operation, and service of Magnetek's material handling products and systems. Anyone who uses, operates, maintains, services, installs, or owns Magnetek products should know, understand, and follow the instructions and safety recommendations in this manual for Magnetek Products.

The recommendations in this manual do not take precedence over any of the following requirements related to cranes, hoists, lifting devices, or other material handling equipment which use or include Magnetek Products:

- Instructions, manuals, and safety warnings of the manufacturers of the equipment where the Magnetek Products are used,
- Plant safety rules and procedures of the employers and the owners of the facilities where the Magnetek Products are being used,
- Regulations issued by the Occupational Health and Safety Administration (OSHA),
- Applicable local, state or federal codes, ordinances, standards and requirements, or
- Safety standards and practices for the industries in which Magnetek Products are used.

This manual does not include or address the specific instructions and safety warnings of these manufacturers or any of the other requirements listed above. It is the responsibility of the owners, users and operators of the Magnetek Products to know, understand and follow all of these requirements. It is the responsibility of the employer to make its employees aware of all of the above listed requirements and to make certain that all operators are properly trained. **No one should use Magnetek Products prior to becoming familiar with and being trained in these requirements and the instructions and safety recommendations for this manual.**

## Product Warranty Information

Magnetek, hereafter referred to as Company, assumes no responsibility for improper programming of a drive by untrained personnel. A drive should only be programmed by a trained technician who has read and understands the contents of this manual. Improper programming of a drive can lead to unexpected, undesirable, or unsafe operation or performance of the drive. This may result in damage to equipment or personal injury. Company shall not be liable for economic loss, property damage, or other consequential damages or physical injury sustained by the purchaser or by any third party as a result of such programming. Company neither assumes nor authorizes any other person to assume for Company any other liability in connection with the sale or use of this product.

### WARRANTY INFORMATION

FOR INFORMATION ON MAGNETEK'S PRODUCT WARRANTIES BY PRODUCT TYPE, PLEASE VISIT [WWW.MAGNETEK.COM](http://WWW.MAGNETEK.COM).



Improper programming of a drive can lead to unexpected, undesirable, or unsafe operation or performance of the drive.

## DANGER, WARNING, CAUTION and NOTE Statements

Read and understand this manual before installing, operating or servicing this product. Install the product according to this manual and local codes.

The following conventions indicate safety messages in this manual. Failure to heed these messages could cause fatal injury or damage products and related equipment and systems.

### DANGERS, WARNINGS and CAUTIONS

Throughout this document DANGERS, WARNING and CAUTION statements have been deliberately placed to highlight items critical to the protection of personnel and equipment.



DANGER indicates an imminently hazardous situation which, if not avoided, will result in death or serious injury. This signal word is to be limited to the most extreme situations.



WARNING indicates a potentially hazardous situation which, if not avoided, could result in death or serious injury.



CAUTION indicates a potentially hazardous situation which, if not avoided, could result in minor or moderate injury. It may also be used to alert against unsafe practices.

**NOTE:** A NOTE statement is used to notify people of installation, operation, programming or maintenance information that is important, but not hazard-related.

**DANGERS, WARNINGS and CAUTIONS SHOULD NEVER BE DISREGARDED.**

### Registered Trademarks

Trademarks are the property of their respective owners.

## Collision Avoidance Unit Warnings



### **WARNING**

Range detector relays should never be electrically or mechanically disabled to be ON or OFF for any crane motion. If the unit is for any reason disengaged or turned off the crane operating personnel must be notified immediately, and proper alternate precautions should be taken.



### **WARNING**

The crane collision avoidance unit and limit switches, if any, should be checked at the beginning of each shift or when a new operator takes control of the crane. When checking the collision avoidance unit and limit switches the hoist should be centered over an area free of personnel and equipment.



### **WARNING**

The collision avoidance unit and limit switches should never be used as a regular stopping device. They are intended to be protective devices.

# 1. LaserGuard Mini System Information

## 1.1. Model Numbers

**LGM – OPEN – R – 10**

**OPEN** = Open Chassis  
**4X** = NEMA 4X Enclosure\*  
\*No bracket or cable suffix. (LGM-4X only)

**10** = 10m laser cable  
**25** = 25m laser cable  
**40** = 40m laser cable  
**75** = 75m laser cable

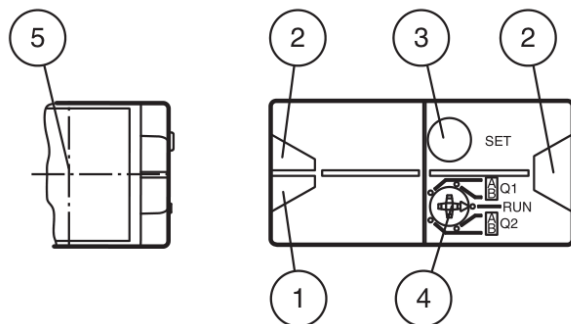
**R** = Rigid mounting bracket  
**H** = Hinged mounting bracket

## 1.2. Class 1 Laser Sensor

Magnetek's LaserGuard Mini Collision Avoidance System contains a Class 1 laser with a 660 nm wavelength. Although the laser is eye-safe, it is recommended that no one look directly into the laser. Do not open the laser sensor enclosure. There are no serviceable parts inside.

## 1.3. System Description

Magnetek's LaserGuard Mini Collision Avoidance System measures the distance between the laser sensor's lens and its companion retro-reflective target by means of pulse ranging technology. This allows for very accurate measurements and energy efficiency. The laser used in the LaserGuard Mini system is set to measure distances from 8 in. to 164 ft (0.2-50m). The laser has a visible red light beam, which makes system alignment very easy. On the front and top of the laser are two LEDs, which indicate power (balloon 1) and alignment (balloon 2). A steady green light indicates power to the laser. In the event of a laser short circuit, the green LED will flash at 4Hz. A yellow light indicates the target is acquired and reading a signal.



1	Operating display	green
2	Signal display	yellow
3	TEACH-IN button	
4	Mode rotary switch	
5	Laser output	

**Figure 1: Laser Optical Unit**

An adjustable mounting bracket is supplied with the system, along with a reflective target. The reflective target is mounted on the wall or other crane that is going to be protected by the collision avoidance system.

The two laser distance set-points are adjustable to trip the relays from approximately 8 in. to 164 ft. (0.2-50m). The first distance set-point (typically a Slowdown point) signals for the crane to start decelerating. The second distance set-point (typically a Stop point) will signal the crane to apply its brakes.

The relationship between these points are as follows:

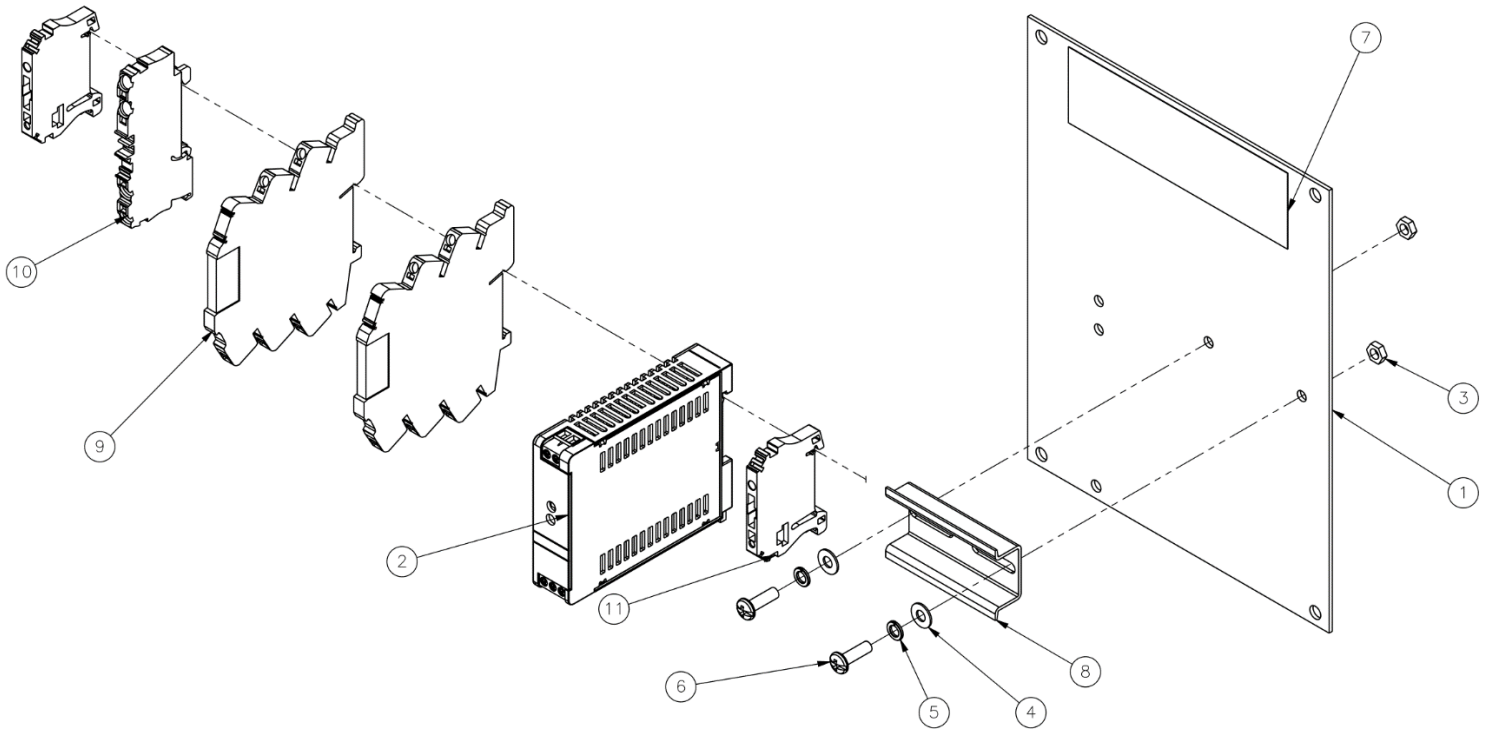
$$164 \text{ ft. (50m)} \geq \text{Slowdown} > \text{Stop} \geq 8 \text{ in. (0.2m)}$$

## 1.4. System Specifications

Specification	Laser Sensor	LaserGuard Mini Models	
		LGM-OPEN-x-x	LGM-4X
Operating Ambient Temperature	-20° to 122°F [-30° to 50°C]	-4° to 141°F [-20° to 60°C]	-4° to 122°F [-20° to 50°C]
Detection Range	8 in.-164 ft. [0.2-50 m]	--	
Input Voltage	--	85-264 VAC or 120-370 VDC	
Accuracy	1 in. [25.4mm]	--	
Hysteresis	Approx. 12 in. [0.3m]	--	
Control Outputs	--	Two form C relays rated at 6A, 270 VAC and 24 VDC	
Laser Class	1	--	
Laser Wavelength	660 nm	--	
Ambient Light Limit	50000 Lux	--	
Enclosure (Standard)	Plastic IP65	Open Chassis	Fiberglass NEMA 4X
Dimensions H x W x D	3.5 x 1.0 x 2.2 in. [88 x 26 x 55 mm]	8.75 x 6.75 x 4.25 in. [222 x 171 x 108 mm]	10.5 x 8.5 x 6.25 in. [267 x 216 x 159 mm]
Weight	0.2 lbs. [0.09 kg]	2.0 lbs. [0.91 kg]	5.6 lbs. [2.54 kg]
Reflector Dimensions	--	2 x 2 ft. [0.61 x 0.61 m]	
Laser Cable Length	--	32.8 ft. [10m], 82 ft. [25m], 131.2 ft. [40m], or 246 ft. [75m]	

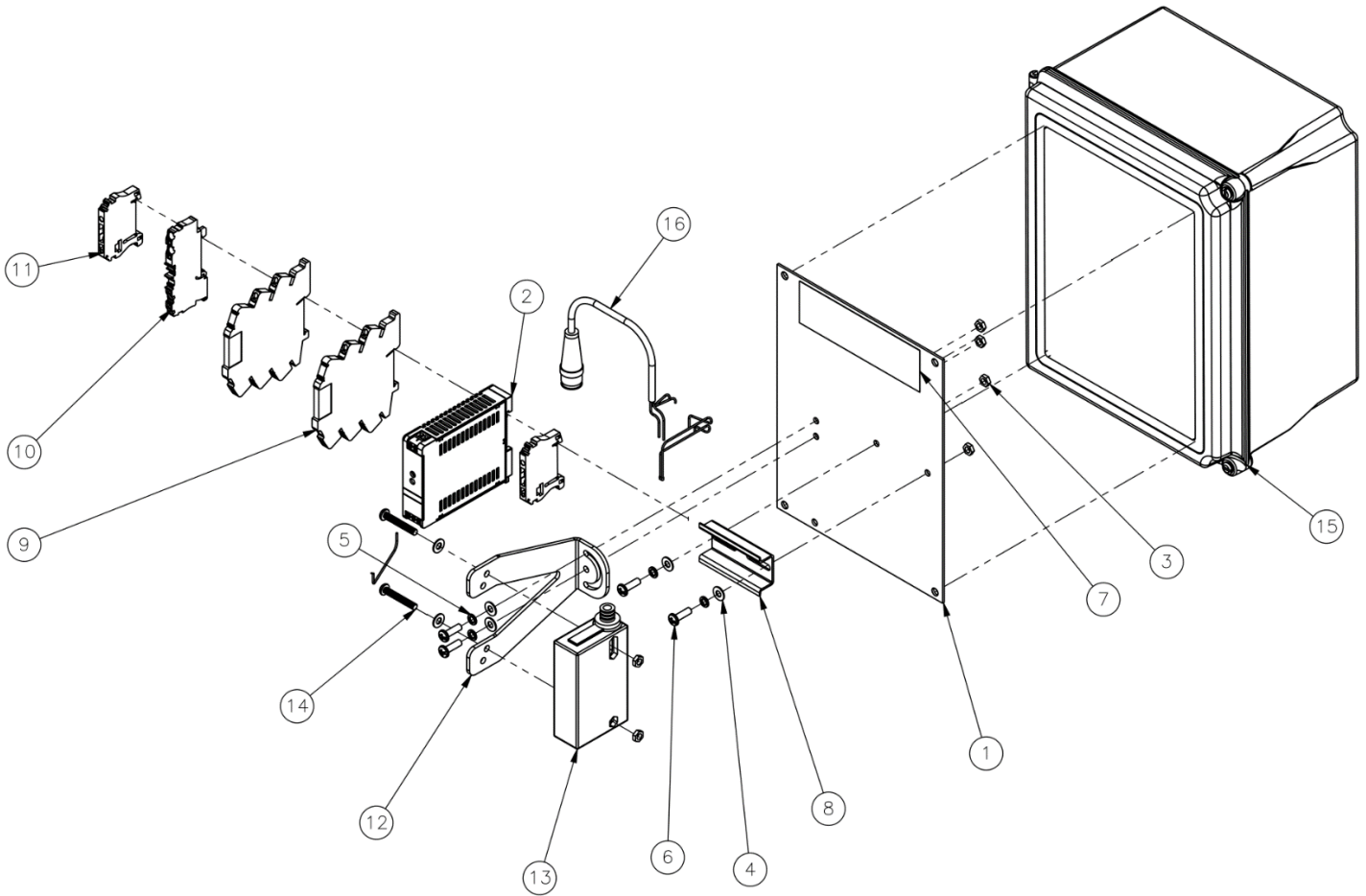


## 1.5. Laser Support Unit Assemblies



ITEM NO.	DESCRIPTION	QTY
1	SUB-PANEL	1
2	POWER SUPPLY, 24VDC, 1.25A	1
3	NUT, #10-32 X 5/16 X 7/64	2
4	WASHER #10 ID X 3/8 OD X .020	2
5	WASHER, LOCK #10	2
6	SCREW COMBO, #10-32 X 5/8	2
7	PRODUCT LABEL	1
8	DIN RAIL	2.5"
9	SPDT RELAY, 24VDC COIL	2
10	GROUND TERMINAL BLOCK	1
11	END-STOP	2

Figure 2: Laser Support Unit (P/N: LGM-LSU-OPEN) Assembly for LGM-OPEN-X-X



ITEM NO.	DESCRIPTION	QTY
1	SUB-PANEL	1
2	POWER SUPPLY, 24VDC, 1.25A	1
3	NUT, #10-32 X 5/16 X 7/64	2
4	WASHER #10 ID X 3/8 OD X .020	2
5	WASHER, LOCK #10	2
6	SCREW COMBO, #10-32 X 5/8	2
7	PRODUCT LABEL	1
8	DIN RAIL	2.5"
9	SPDT RELAY, 24VDC COIL	2
10	GROUND TERMINAL BLOCK	1
11	END-STOP	2
12	LASER MOUNTING BRACKET	1
13	LASER SENSOR	1
14	SCREW, #10-32 X 1-1/4	2
15	NEMA 4X ENCLOSURE	1
16	0.5M LASER CABLE	1

**Figure 3: Laser Support Unit (P/N: LGM-LSU-4X) Assembly for LGM-4X**

## 2. Electrical Installation

### 2.1. Voltage Considerations

Check the specification table or system drawings for proper line input voltage and supported relay voltages. If there are any questions, contact Magnetek before applying power to the system.



THE UNIT MUST BE WIRED TO THE CORRECT VOLTAGE. FAILURE TO DO SO MAY DAMAGE THE SYSTEM.

**NOTE:** The collision avoidance system should not be connected to lines containing excessive power up transients or continuous commutator noise. A line conditioner may be necessary in some installations.

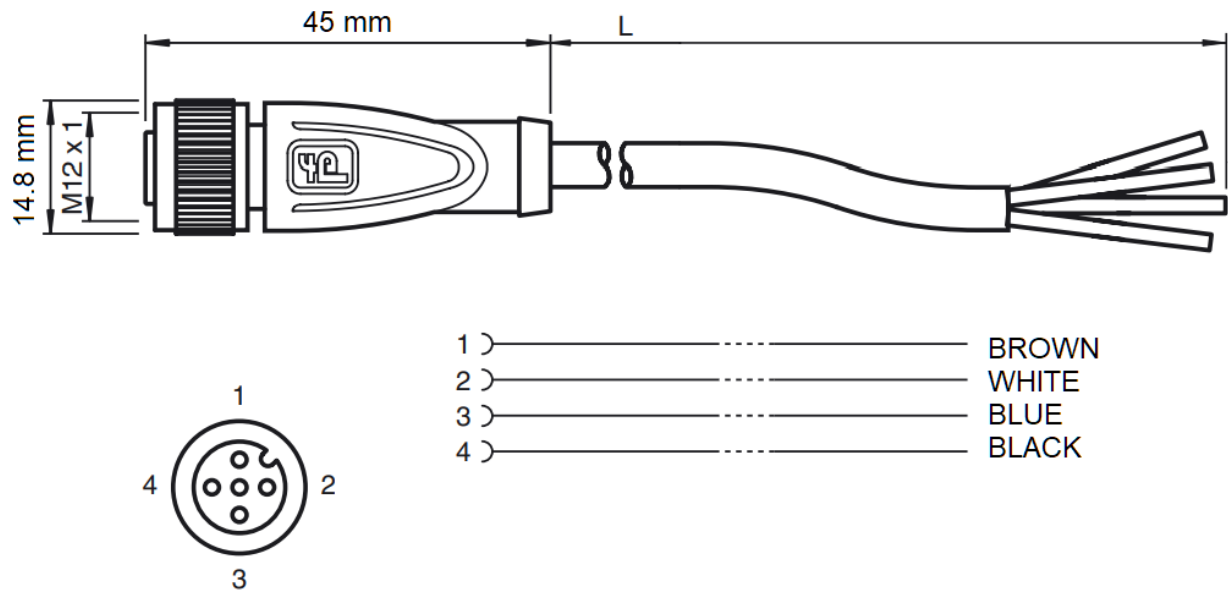
### 2.2. Wiring Considerations

1. Do not connect or disconnect wiring or perform circuit checks while the power is turned on.
2. Power supply wiring shall be in a metal conduit and separate from any motor wiring.
3. Control wiring shall be in separate conduit and shall be kept as short as possible.
4. Please observe National Electric Code (NEC) when wiring electrical devices.
5. When cutting holes in the cabinet, take care to prevent metal filings from shorting the circuitry. Remove any metal screws, metal filings, and wire clippings from inside of the unit.
6. Inspect to make sure no exposed wire has contact with any other wiring or terminals.
7. Suppressors are strongly recommended on all contactors.

### 2.3. Wiring Instructions

1. Connect power to the power supply (85-264 VAC or 120-370 VDC) terminals “+” and “-”.
2. Wire both relays according to Figure 4 and 5. The acceptable wire size is 24 to 14 AWG. Please observe National Electrical Code (NEC) guidelines when wiring electrical devices.
3. Connect a ground wire to the dedicated ground terminal block.
4. Turn on the power and verify the green LED on the laser sensor is on continuously after a few seconds. If that does not occur, turn the power off and recheck all wiring.

## 2.4. Laser Cable and Relay Wiring



PIN NO.	WIRE COLOR	CONNECTION POINT ON LASER SUPPORT UNIT
1	BROWN	"+" Terminal of Power Supply
2	WHITE	"A1+" Terminal of Relay 2
3	BLUE	"-" Terminal of Power Supply
4	BLACK	"A1+" Terminal of Relay 1

Figure 4: Laser Cable Wiring Diagram

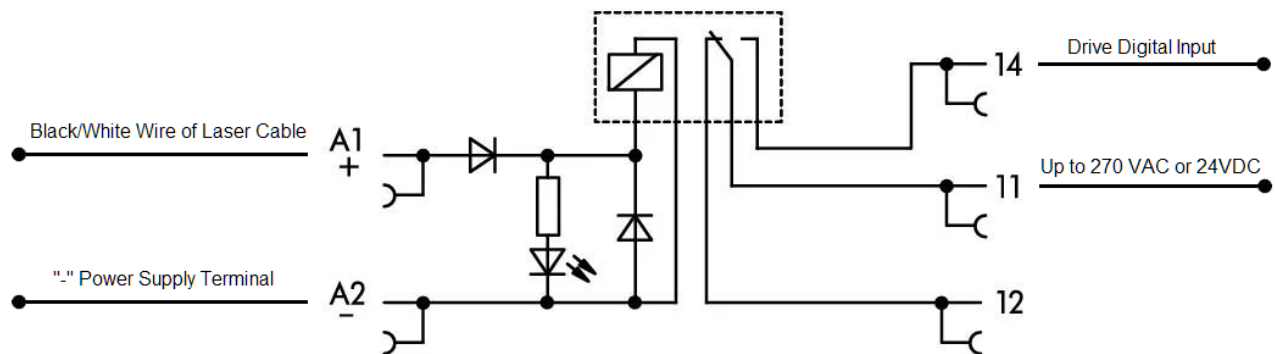


Figure 5: Relay Wiring Diagram

## 2.5. Wiring Example

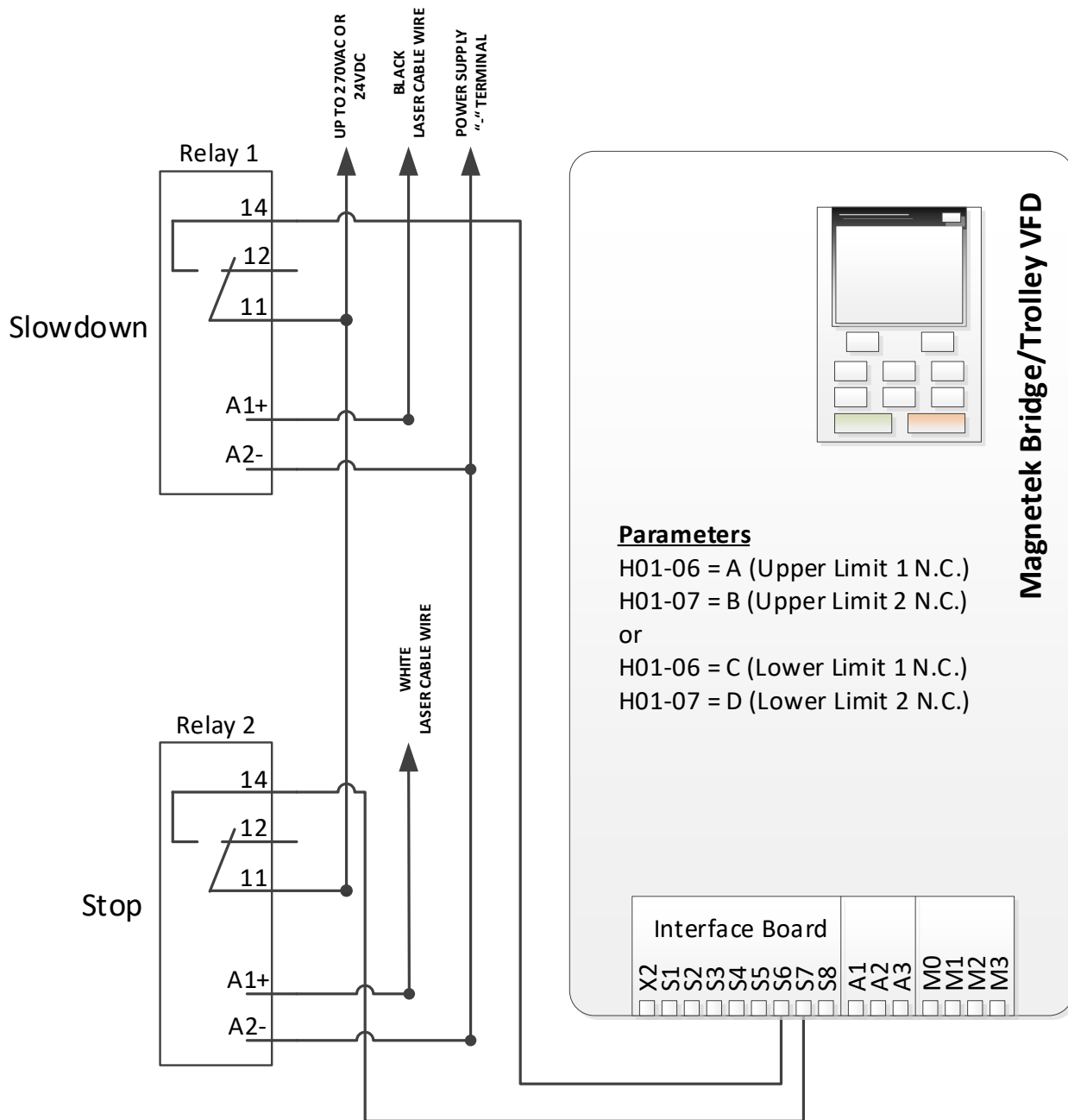


Figure 6: Magnetek VFD Example Wiring Diagram

**NOTE:** The voltage switched through the relays must comply with the drive's interface board voltage.

### 3. Mechanical Installation



## CAUTION

THE LASERGUARD MINI SYSTEMS ARE NOT RATED AS EXPLOSION PROOF. THE UNIT MUST NOT BE INSTALLED IN EXPLOSIVE ENVIRONMENTS UNLESS APPROPRIATE SECONDARY ENCLOSURE MEASURES ARE TAKEN.

#### 3.1. Mounting Location Considerations

Ensure the mounting location is as far as possible from exposed trolley wires and sources of electromagnetic or radiated noise.

If possible, avoid installation on a surface where high vibration or shock is present. If this cannot be avoided, use appropriate shock mounts.

#### 3.2. Laser Dimensions

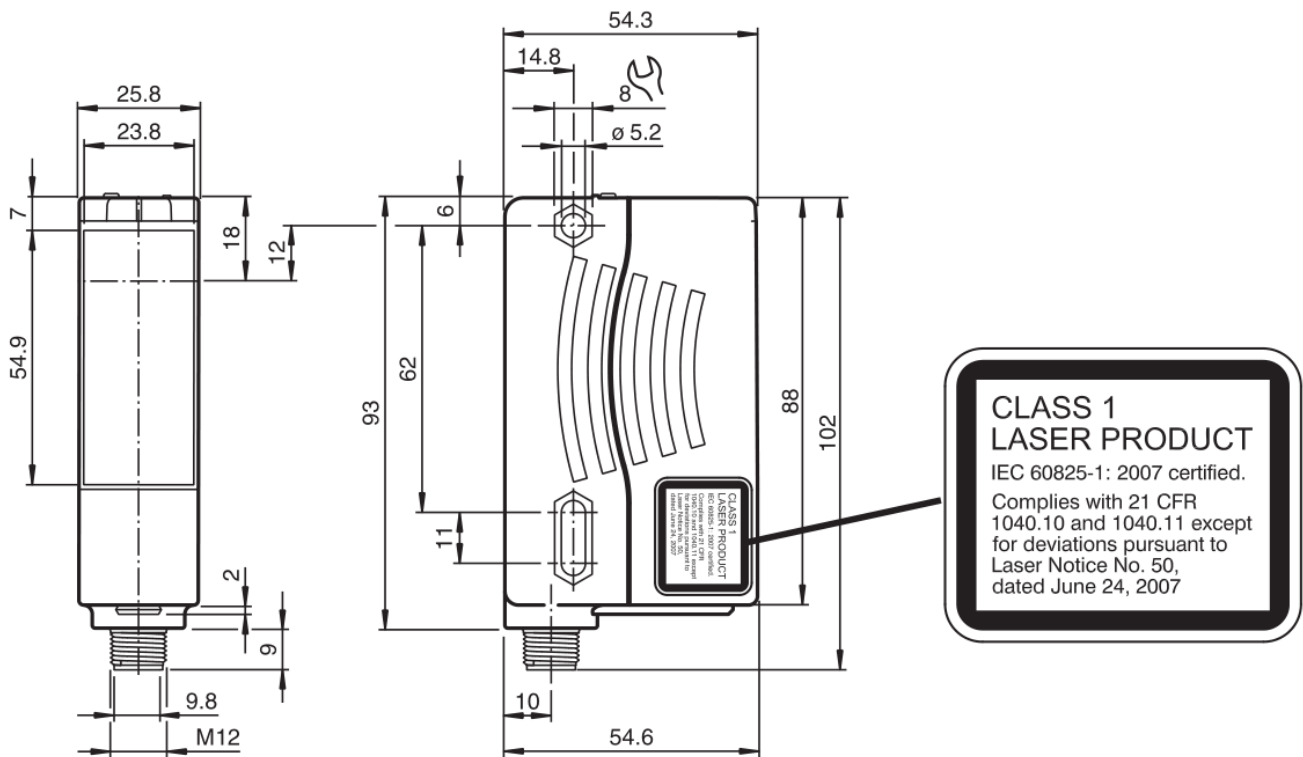
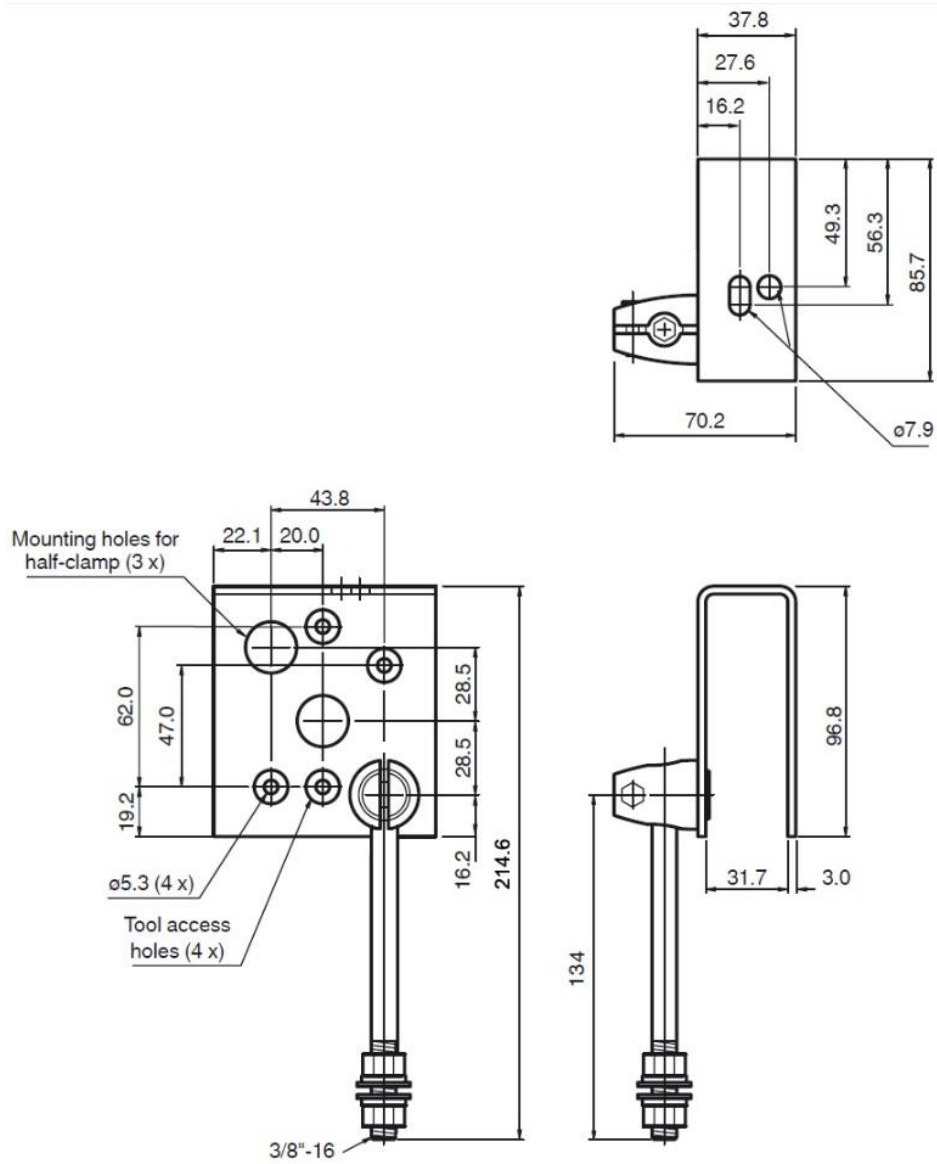


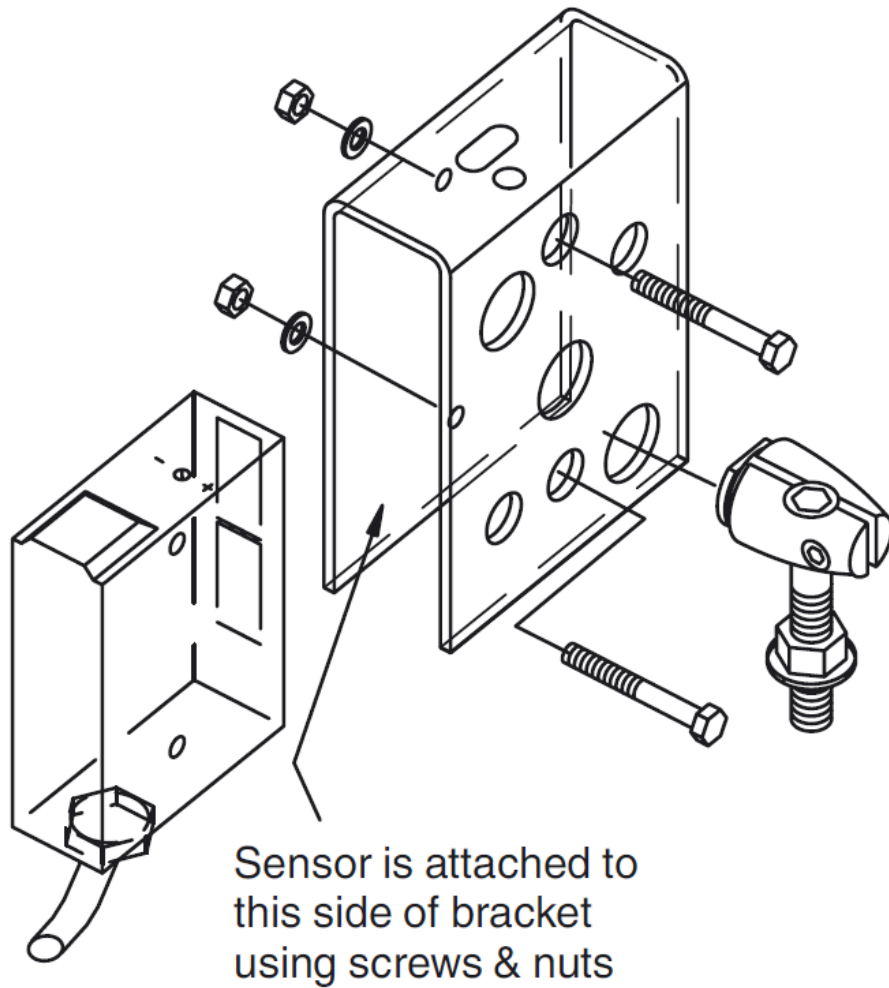
Figure 7: Laser Sensor (P/N: LGM-HEAD) Dimensions (mm)





**Figure 9: Hinged Laser Mounting Bracket (P/N: HINGED-BRACKET) Dimensions (mm)**





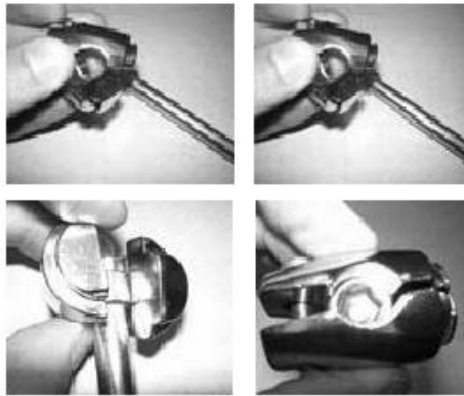
**Figure 10: Hinged Laser Mounting Bracket Assembly**

**NOTE:** Laser shown for reference only.



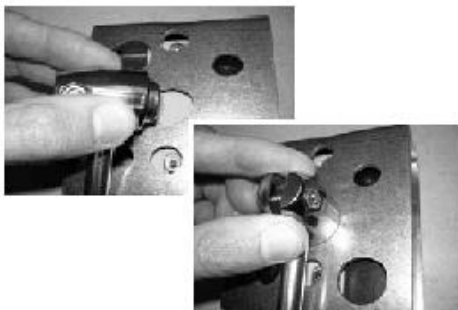
To assemble, the sensor must be mounted inside the sensor shroud. Slide the two screws through the shroud and sensor with the two washers and two nuts on the outside of the shroud. Tighten the screws in place.

Step 1



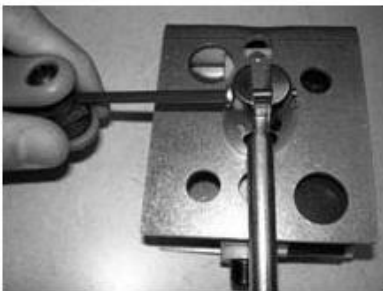
Loosen the half-clamp and observe the grooved slot inside. Place the head of the mounting bolt/rod into this groove.

Step 2



Without tightening the half-clamp over the bolt head, squeeze the clamp together so the smaller protrusion at the end fits together, and place it into one of the three larger holes on the side of the shroud.

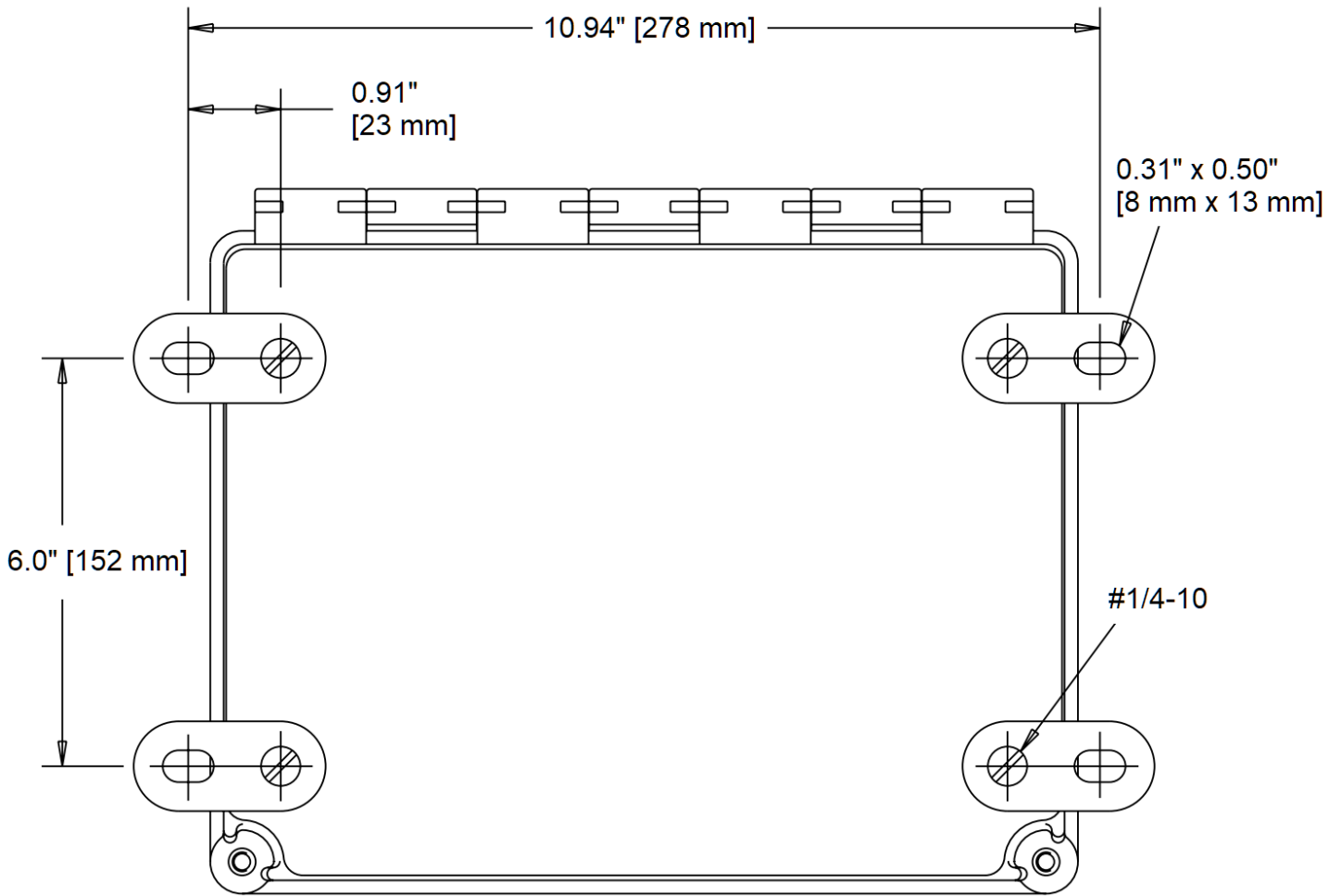
Step 3



Position and align the mounting bracket to the reflector, then tighten the half-clamp set screw to secure the assembly

Step 4

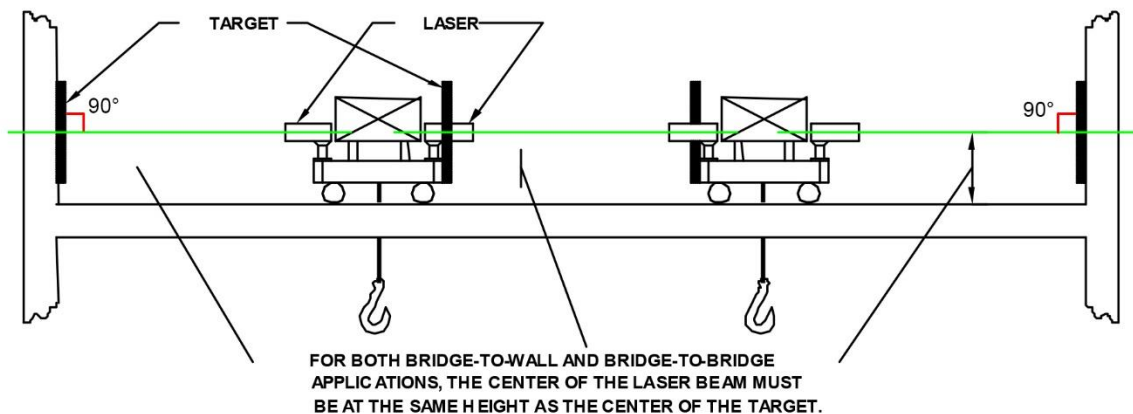
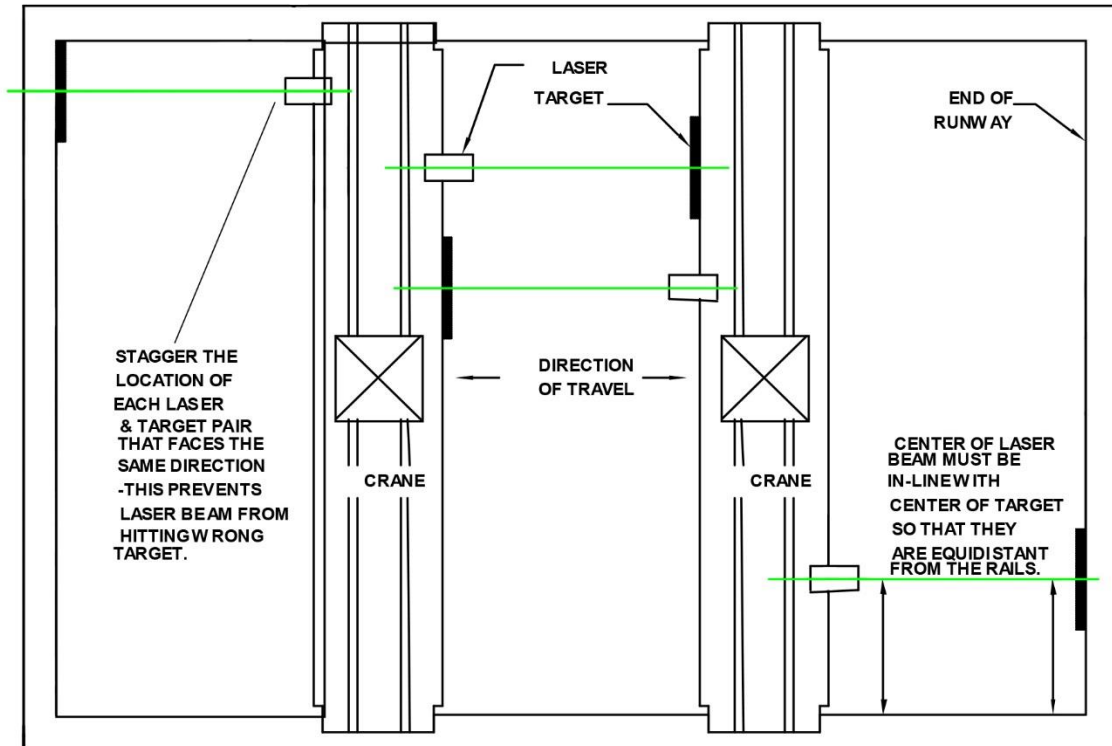
**Figure 11: Hinged Laser Mounting Bracket Instructions**



**Figure 12: LGM-4X & 4X-ENCLOSURE Mounting Instructions**

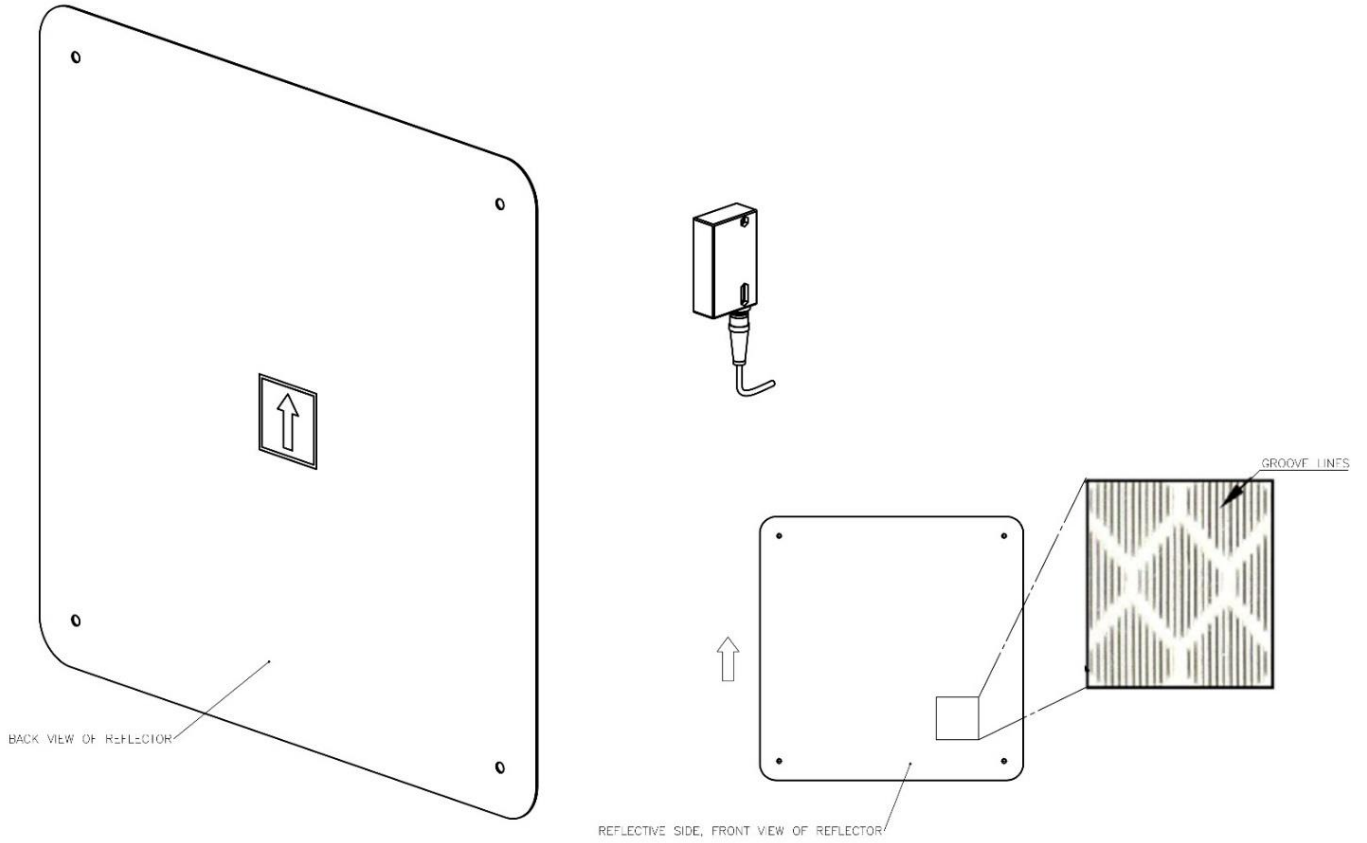
**NOTE:** The (4) enclosure mounting feet are included as ship-along parts.

Install the sensor laser and reflective target as indicated in Figure 13 and Figure 14. Mount the laser sensor securely to a solid surface to minimize vibration so that the crane's load or movement will not affect the laser's alignment. The laser and laser support unit should also be mounted as close to the control panel as possible to minimize long cable runs.

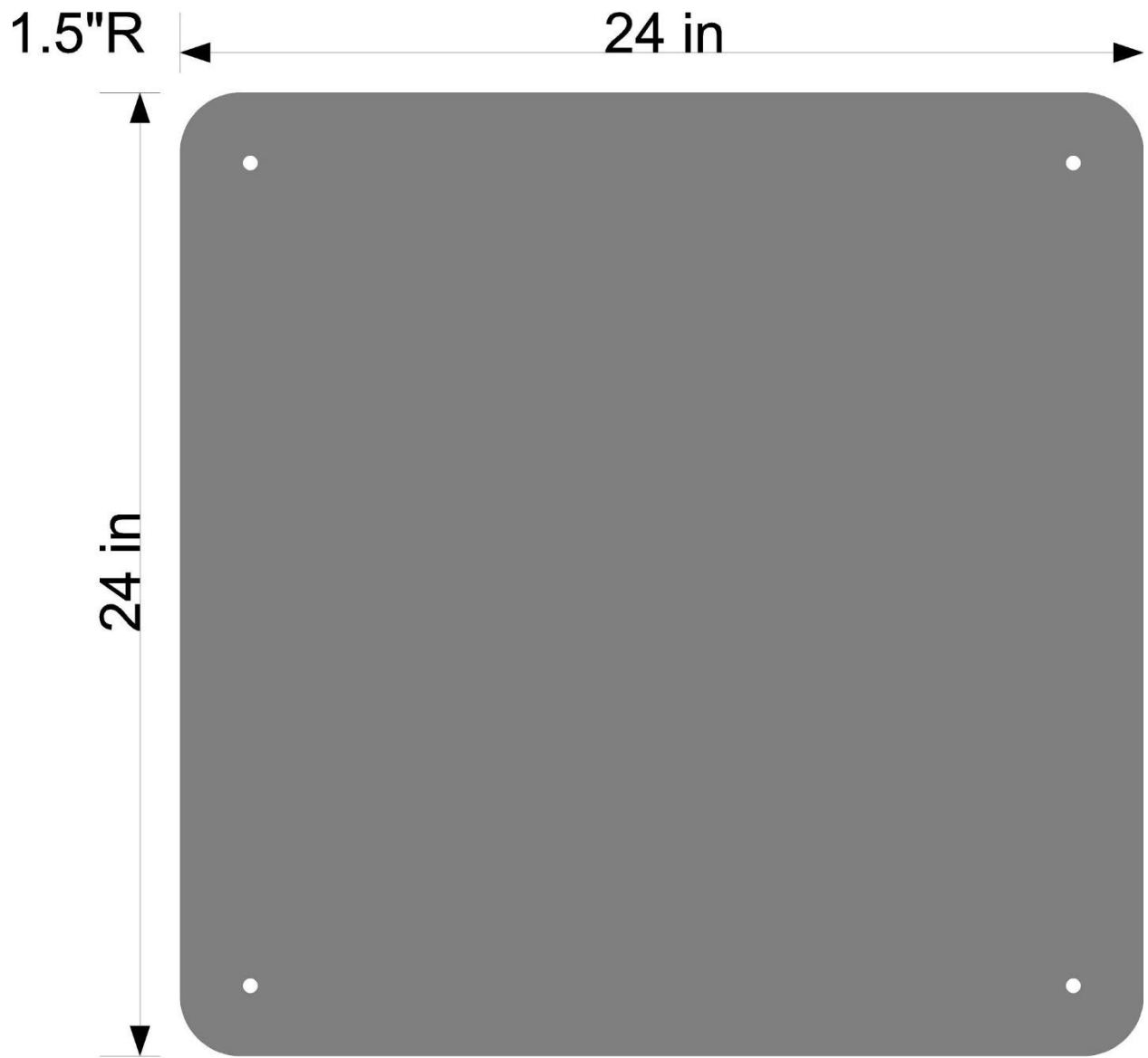


**Figure 13: Laser and Target Installation**

For best reflectivity/laser signal, mount the reflector in the same orientation as the laser so the laser beam is perpendicular to the reflective target. The arrow on the back of the reflector should be the same direction as the laser (refer to Figure 14).



**Figure 14: Laser and Reflective Target Orientation**



24" Square 0.063 - 0.08 gauge, 1.5" Rad  
w/ (4) 3/8" holes 1.75" in on corners

Figure 15: Reflector Target Dimensions (P/N: REFLX-REFLECTOR-DIN)

### 3.4. Electrical Conduit Installation

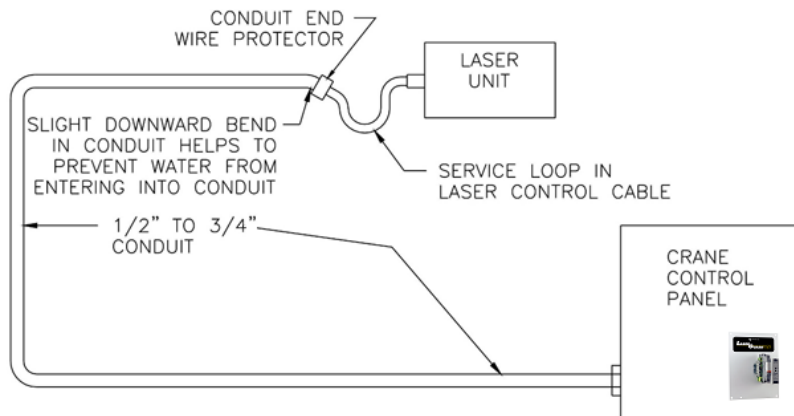
The laser sensor cable and all other wiring should be run in separate 1/2" or 3/4" conduit. Do not run any other cables in the same conduit as the laser sensor cable.

A suitable disconnect should be provided by the installer to allow a controlled power-down.

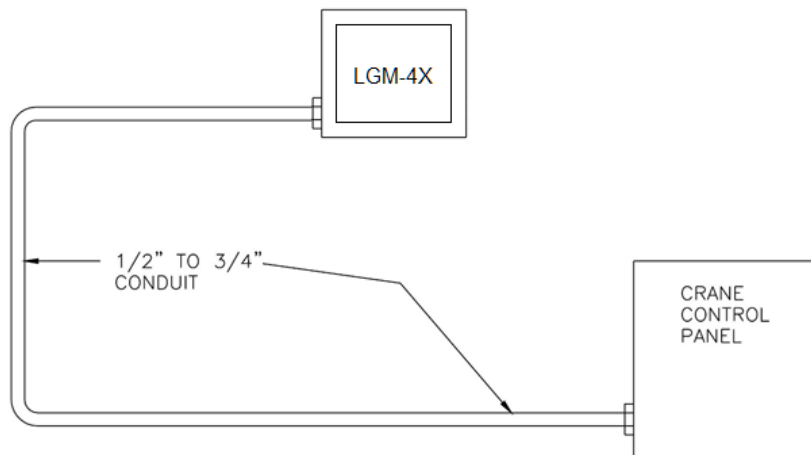
Run conduit between the laser sensor and the crane's control panel. Putting a slight downward bend in the conduit at the laser transceiver will help keep dirt and water out. Place a protective end piece on the open end of the conduit to protect the laser cable from sharp edges.

Pull the supplied laser cable by the end that does not have a connector on it through the conduit, starting from the opened laser sensor end. Leave enough cable on the laser end so that it is twice as long as the distance between the end of the conduit and the laser unit (about 2 ft. to 3 ft. [0.6m to 0.9m]). This will produce a service loop, which will also help keep dirt and water out of the open end of conduit (refer to Figure 16).

This laser cable consists of four wires. See 4 for wiring information for this cable. Plug the connector into the laser sensor. The connector is keyed; do not force.



**Figure 16: Conduit Installation (Open Chassis Models)**



**Figure 17: Conduit Installation (NEMA 4X Model)**

## 4. Functional Installation

### 4.1. Laser Distance Set-Point Adjustment

The laser distance set-points are defaulted at:

1. Set-Point 1 (Slowdown): 4 ft. (1219 mm)
2. Set-Point 2 (Stop): 2 ft. (609 mm)

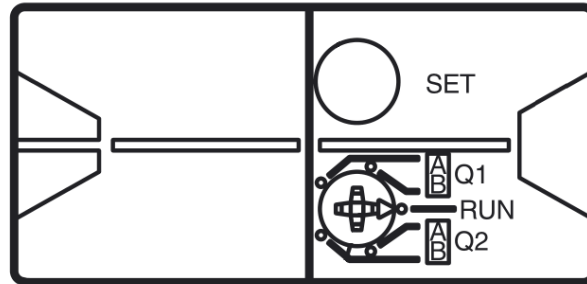


Figure 18: Laser Sensor Button & Switch Layout

**NOTE:** Setting the detection points will require movement of the crane to the desired distances.

To set (teach-in) new laser distance set-points:

1. Move the crane to the point at which the **slowdown** is desired.
2. Set rotary switch to **Q1 A**
3. Press and hold the SET button on the laser sensor for 1-2 seconds. When the yellow and green LEDs turn on, release the SET button to set the distance. Verify that the LED's alternatively blink at 2.5hz. This indicates that the teach-in was successful.
4. Move the crane to the point at which the **stop** is desired.
5. Set rotary switch to **Q2 A**
6. Press and hold the SET button on the laser sensor for 1-2 seconds. When the yellow and green LEDs turn on, release the SET button to set the distance. Verify that the LED's alternatively blink at 2.5hz. This indicates that the teach-in was successful.
7. Return the rotary switch to the **RUN** position
8. Move the crane away from the target and then back again to verify the relays are triggered at the correct distances.



## 4.2. Troubleshooting

LED	COLOR	FUNCTION
Laser Head Operating Display	Green	Monitors voltage to the Laser Head Normally ON.
Laser Head Signal	Yellow	Monitors target acquisition. Normally ON when target is acquired. It turns off when the laser is off the target, out of range, or has a dirty lens. Random or rapid flashing of this LED could indicate a weak signal caused by too much of a reflector angle. Make sure the reflector is not bent, and that its orientation is per Figure 14. Groove lines visible on the reflective material should be in the same direction as the laser sensor orientation.
Laser Distance Teach-In Not Successful	Green & Yellow	The yellow and green signal LEDs flash quickly in alternation (8 Hz). After an unsuccessful teach-in, the sensor continues to operate with the previous valid setting after the relevant visual fault signal is issued.

**Table 1: Laser Diagnostic LED Functions**

**NOTE:** See Figure 1 for LED locations.