

900D

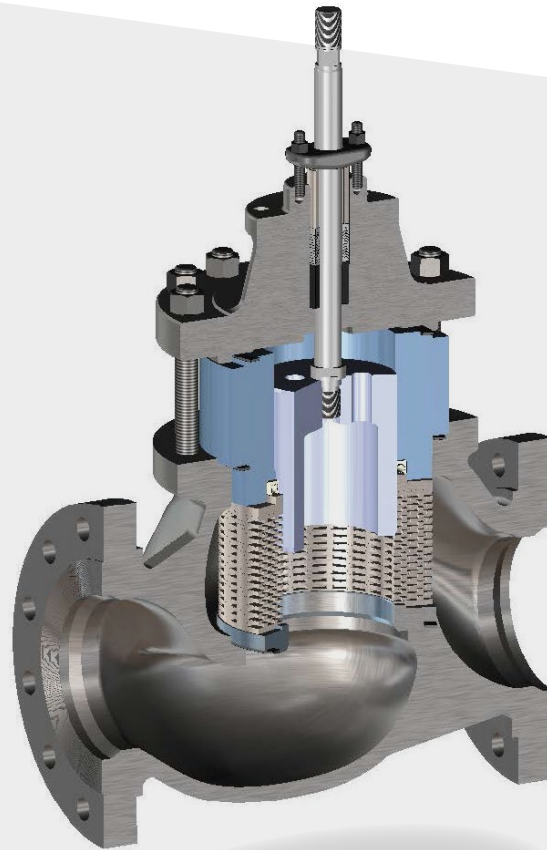

Engineering
GREAT Solutions

DRAG® Control Valve

900D Control Valve

IMI CCI's DRAG® technology, pioneered in 1961, is the industry's leading solution for handling demanding service conditions. The 900D is designed to deliver peak process performance with superior control while minimising losses caused by valve leakage. IMI CCI's proven DRAG® technology will reduce your equipment and maintenance costs through dramatic reductions in cavitation and vibration – the root cause of damage to trim, adjacent equipment and piping. Supported by the world class technical expertise of the Valve Doctor® program, the 900D is a continuation of IMI CCI's industry leading critical application solutions that customers have come to depend on.

Fully characterisable,
multi-stage DRAG® trim

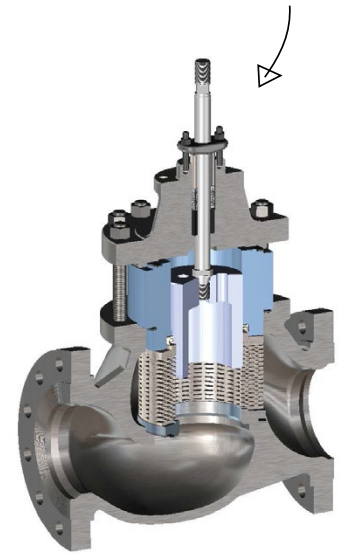

Key features

- > **Multi-stage DRAG®**
 - Eliminates cavitation, noise and vibration
 - Increases life and reduces maintenance costs
- > **Tight shutoff**
 - Reduces leakage
 - Available in Class IV, Class V & VI with soft seat
- > **Top entry design**
 - Teflon and graphite seals available
- > **Trim characterisation**
 - Linear and equal percentage
 - Custom characterisation available to match specific process requirements
- > **Easy maintenance**
 - Quick change trim allows for ease of maintenance, no internal components are screwed or welded into valve body or bonnet

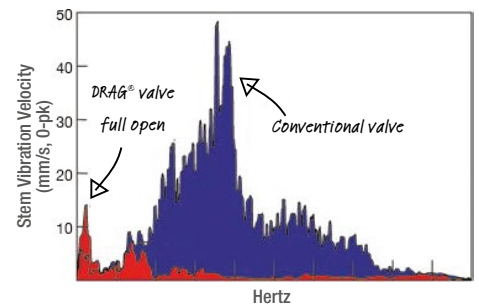

Chart 1: Stem vibration velocity for a conventional valve before retrofit (blue line) and after retrofit with DRAG® trim (red line)

Benefits

- > **Control and reliability**

The 900D continues IMI CCI's tradition of customising valve performance to meet the exacting requirements of your application. In addition to linear and equal percentage characterisation, the 900D can be custom characterised for applications that require critical control
- > **Solves cavitation**
 - Maintains the fluid velocity at minimum levels so that local pressures are unlikely to drop below the fluids vapour pressure
 - Should gas bubbles form, DRAG® reduces the energy to a safe level by dividing the flow into many small channels
 - The 900D adheres to ISA guidelines on trim exit velocity
- > **Solves vibration**

IMI CCI has extensive experience in helping customers eliminate the damage caused by vibration. Chart 1 shows the dramatic results of applying DRAG® technology and kinetic energy control. Customers typically experience a 90% decrease in peak vibration with the application of DRAG®, and that enables them to:

 - Eliminate valve and piping damage.
 - Minimise system trips
 - Minimise downtime and maintenance costs
 - Eliminate additional piping supports
- > **Solves noise**

IMI CCI's philosophy on noise control is to avoid the creation of noise as opposed to trying to muffle it once it's produced. With the 900D the amount of noise that must be absorbed by the pipe wall or insulation is dramatically reduced, and the noise sensed in the vicinity of the valve is at acceptable levels:

 - DRAG® operates <85 dba
 - Eliminates worker safety concerns
 - Eliminate additional insulation & acoustic barriers
 - Maximise process flow rates

Materials

Component	Item No.	Material Options
Body	1	Carbon steel, chrome-moly steel, stainless steel, other
Bonnet	2	
Plug	3	316SS Chr Plt or Stellite, 410 SS HT, Inconel 625, UNS S31803 Chr Plt or Stellite, F11 Stellite, F22 Stellite
Stem	4	316SS Chr Plt, UNS S31803 Chr Plt, 410 SS Heat Treated, Inconel 718, 17-4PH H1150M
Seat	5	316 SS, 316 SS with Stellite, 410 SS Heat Treated, Inconel 718, UNS S31803, UNS S31803+Stellite, F11+Stellite, F22+Stellite
Disk Stack	6	316 SS, 410 SS, Inconel 718, S31803
Balance Cylinder	7	Carbon steel, chrome-moly steel, stainless steel, other
Balance Seal	8	PTFE + 316 SS, Graphite
Seat Gasket	9	347 SS with Graphite Filler
Body/Bonnet Gaskets	10	347 SS with Graphite Filler
Packing Spacer	11	316 SS
Packing Set	12	Glass Filled PTFE, Graphite
Packing Follower	13	316 SS

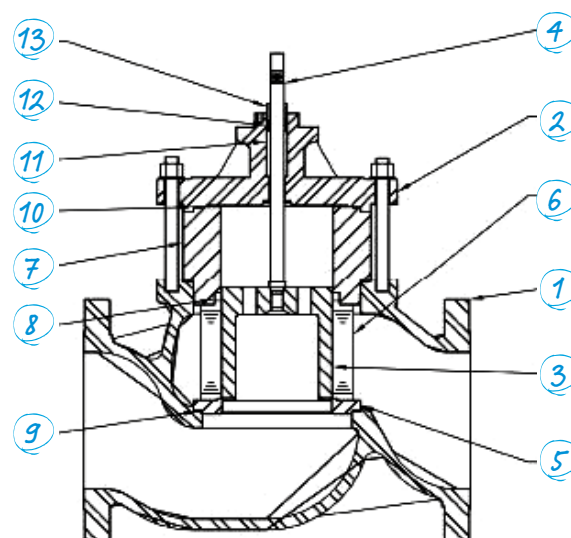

Performance data

Body type

Globe/Angle

Fail mode

Open, Close, In-Place

Shut-off class, ANSI/FCI 70.2

Class IV, V, VI (Soft Seat)

Valve sizes

1" through 16"

Face to face

ISA 75.08 - 2002

Trim characteristics

Linear / Equal Percentage / Custom Characterisation*

Pressure rating (ANSI class)

150, 300, 600, 900, 1500, 2500

Flow direction

Flow-To-Close (Liquids)
Flow-To-Open (Gas)

Internal actuator type options

IMI CCI Spring Diaphragm
IMI CCI Double Acting Piston

End connections

Raised Face Flange
RTJ Flange,
Butt Weld End

Temperature

-50°F to 975°F (-46°C to 525°C)

Stroke time**

< 30 sec (standard)/ < 1 sec to open,
< 5 sec to close (fast stroke)

*Designed specifically to match customers process requirements **Lower stroking times upon request

Applications

> Oil & Gas

- Extraction Steam Control
- Fire Water Pump Recirculation
- Fire Water Pump Discharge
- Gas Injection
- Gas Withdrawal (Clean)
- Emergency and Service Vents
- Fuel Gas Regulation Valves
- Compressor Anti-surge
- Hot Gas Bypass
- Process gas to Vent/Flare
- Expander Bypass (JT Valves) (non-cryogenic)
- Feedstock Flow/Pressure Control
- Passivation Valve
- Feedgas Regulator
- Lean Amine Pump
- Recirculation Control
- Produced Water Injection (Clean)

> Power application

- HP Heater Emergency Drains
- Feedwater Regulators
- Startup Feed Regulators
- Soot Blowing
- General Turbine Island BOP
- Condensate Pump Recirculation
- Supercritical Startup Valve
- Deaerator Level Control
- DA Pegging
- Auxiliary Steam PCV

> Nuclear application

- Atmospheric Dump
- Feedwater Pump Recirculation
- Auxiliary Steam to Deaerator
- Blow Down
- Condensate Drain
- Deaerator Level Control
- Feedwater Heater Drains
- Steam Bypass
- Condenser Dump (Turbine Bypass)
- Feedwater Regulator
- Condensate Pump Recirculation

Americas

imiccisales.americas@imi-critical.com

IMI CCI Brazil

Sao Paulo
Brasil

Tel: +55 11 2691 3361

IMI CCI Houston

Texas
USA

Tel: +1 832 467 7200

IMI CCI RSM

California
USA

Tel: +1 949 858 1877

Asia-Pacific

imiccisales.apac@imi-critical.com

IMI CCI Australia

Melbourne
Australia

Tel: +61 3 9213 0800

IMI CCI Japan

Kobe
Japan

Tel: +81 78 322 1220

IMI CCI Korea

Paju-si
Korea

Tel: +82 31 980 9800

IMI CCI Malaysia

Kuala Lumpur
Malaysia

Tel: +60 3 6412 3500

IMI CCI Singapore

Singapore

Tel: +65 6653 7000

IMI Critical Engineering

Lakeside, Solihull Parkway
Birmingham Business Park
Birmingham B37 7XZ
United Kingdom

Tel: +44 (0)121 717 3700

Fax: +44 (0)121 717 3701

www.imi-critical.com

China

imiccisales.china@imi-critical.com

IMI CCI China

Shanghai
PR China

Tel: +86 21 3973 8000

Europe

imiccisales.europe@imi-critical.com

IMI CCI Austria

Wien
Austria

Tel: +43 1 869 27 40

IMI CCI Brno

Brno
Czech Republic

Tel: +420 511 188 288

IMI CCI Italy

Milano
Italy

Tel: +39 02 4345 8611

IMI CCI Sweden

Säffle
Sweden

Tel: +46 533 689 600

IMI CCI Switzerland

Balterswil
Switzerland

Tel: +41 52 264 9500

IMI CCI United Kingdom

Manchester
UK

Tel: +44 (0)161 655 1680

India

imiccisales.india@imi-critical.com

IMI CCI Bangalore

Bangalore
India

Tel: +91 80 4030 3500

IMI CCI SriCity

Andhra Pradesh
India

Tel: +91 85 7639 8000

Middle East and Africa

imiccisales.mea@imi-critical.com

IMI Critical MEA

Dubai
United Arab Emirates

Tel: +971 4 807 3111

IMI CCI South Africa

Witbank
South Africa

Tel: +27 13 697 3305

Other

imicci.sales@imi-critical.com



Critical Engineering

01010.03/18en