



D-Pack Deluge Cabinet

TECHNICAL DATA :

MODEL	D-PACK
NOMINAL SIZE	150, 100, 80 & 50NB
MAXIMUM SERVICE PRESSURE	12 Bar (175 psi)
THREADED OPENING	BSPT
FACTORY HYDROSTATIC TEST PRESSURE	25 Kg./sq.cm. (350 psi)
FLANGE CONNECTION	ANSI B16.5 RF #150
TRIM	Galvanized steel with brass valves (optional SS with brass valves)
RECOMMENDED FLOW RATE	150NB - 170 to 650 m ³ /hr 100NB - 50 to 225 m ³ /hr 80NB - 30 to 110 m ³ /hr 50NB - 10 to 55 m ³ /hr
FRictional LOSS IN TERMS OF EQUIVALENT LENGTH OF PIPE (C-120)	150NB - 19.00 metres 100NB - 11.00 metres 80NB - 5.50 metres 50NB - 1.80 metres
WET PILOT SPRINKLER HEIGHT LIMITATION	As per graph in the catalogue.
FINISH	Fire Red PU painted.
ORDERING INFORMATION	Size and trim details.

GENERAL DESCRIPTION

D-Pack is pre-assembled Deluge system package built around UL listed Deluge Valve Model -A with three different types of actuations - pneumatic release , hydraulic release and electric release .

Deluge Valve is known as a system control valve in a deluge system, used for fast application of water in a spray system. Deluge valve protects areas such as power transformer installation, storage tank, conveyor protection and other industrial application etc. With the addition of foaming agent they do protect aircraft hanger and inflammable liquid fire.

D-Pack consists of pre-assembled Deluge system mounted on the square tube frame (skid) and is enclosed from all sides with removable panels with front side open or with a option of hinged doors with lock for front side. Glass openings are provided on the doors for viewing the pressure gauges. The entire package is pre wired and connections are flanged to provide minimal installation time. The package includes inlet, outlet and bypass valve, pressure switches , solenoid valves , inlet and outlet connections , common drain connection and junction box for electrical connection. Pressure switches are provided on the outlet of the deluge valve to indicate the actuation of the valve. In addition to this one more pressure switch is provided in pneumatic line for indication of low pressure or fire condition with pneumatic release trim

The skid panels are of galvanized steel of minimum 14 SWG. The panels and the skid frame are painted with fire red PU paint. The skid is provided with corrosion resistant stainless steel nameplate. Stainless steel labels are provided for valves for easy identification.

INSTALLATION

1. Place the skid at the desired location on the proper foundation and secure it with the anchoring bolts.
2. Connect the water inlet and system piping.
3. Connect the common drain connection to a open drain. Do not restrict or reduce the drain piping.
4. Connect the detection network piping to the cabinet
5. Complete the field wiring of junction box.
6. For commissioning, testing and troubleshooting follow the procedure outlined below.

Note : Support the external piping firmly to prevent strain and stresses on the piping of the cabinet and its components.

VALVE OPERATION

Deluge valve is a quick release, hydraulically operated diaphragm valve. It has three chambers, isolated from each other by the diaphragm operated clapper and seat seal. While in 'SET' position, water pressure is transmitted through an external bypass check valve and restriction orifice from the system supply side to the

D-Pack Deluge Cabinet

top chamber, so that supply pressure in the top chamber acts across the diaphragm operated clapper which holds the seat against the inlet supply pressure because of differential pressure design. On detection of fire the top chamber is vented to atmosphere through the outlet port via opened actuation device(s). The top chamber pressure cannot be replenished through the restricted inlet port, thus it reaches less than half the supply pressure instantaneously and the upward force of the supply pressure lifts the clapper allowing water to enter the system piping network and alarm devices.

TRIM DESCRIPTION

a) BASIC TRIM

The basic trim is required on deluge valve regardless of the release system. It contains those components which are required in all types of installation, such as the main drain valve, priming connection, drip check valve, emergency release valve and pressure gauges.

b) DRY PILOT TRIM (PNEUMATIC RELEASE)

Dry pilot operation uses a pilot line of closed Sprinklers/ QB detectors containing air under pressure, located in the area to be protected. It requires regulated dry air supply with main supply point through restricted orifice. The pilot line is connected directly to the top of POSITIVE DRAIN ACTUATOR (PDA). The bottom of PDA is connected to the top chamber of the deluge valve.

When the air pressure drops, due to release of any of the release devices on detection of fire, the diaphragm of PDA is lifted and allows the water to drain. This reduces the water pressure in the top chamber of the deluge valve and when the pressure in the top chamber reaches 50% of the supply pressure, the deluge valve opens. The direct drain of PDA starts when the top chamber pressure of deluge valve reaches approximately 0.5 Kg./sq.cm. This positive drain will not permit the deluge valve to close unless the PDA is set manually. The recommended air supply pressure is as per TABLE-1.

TABLE - 1

LINE WATER PRESSURE Kg./ Sq.cm. MAXIMUM	AIR PRESSURE IN DETECTION LINE Kg./ Sq.cm.	
	MINIMUM	MAXIMUM
2	1.2	3.0
4	1.5	3.0
6	2.0	3.5
8	2.5	3.5
10	3.0	3.5
12	3.5	4.0

c) WET PILOT TRIM (HYDRAULIC RELEASE)

Wet pilot operation uses a pilot line of closed sprinklers containing pressurised water, supplied through the upstream side of the deluge valve, through a restricted orifice. All the release lines are connected to a common release line. Due to release of any one of the release devices, the water pressure in the top chamber of the deluge valve reaches 50% of the supply pressure, the deluge valve opens.

CAUTION

While using a deluge valve in the wet pilot system the height and the length of the wet pilot detection line is to be limited as given in the wet pilot sprinkler height limitation graph.

d) ELECTRIC RELEASE TRIM

To actuate a deluge valve electrically, a solenoid valve is provided to drain the water from the top chamber of the deluge valve. A pressure switch is provided to activate an electric alarm, to shut down the desired equipment

or to give "Tripped" indication to the panel. In addition to this two nos of pressure switches can be used to monitor "Low air pressure" and "Fire condition" when used in dry pilot air line.

e) TEST AND ALARM TRIM WITH SPRINKLER ALARM

This trim is supplied with the sprinkler alarm bell, which bells on actuation of the deluge valve. A test valve is provided to test the normal operation of the sprinkler alarm bell.

RESETTING PROCEDURE FOR THE DELUGE VALVE

- (i) Close the upstream side stop valve provided below the deluge valve.
- (ii) Open both the drain valves and close them when the flow of water has ceased.
- (iii) Inspect and release if required, or close the section of the detection system subjected to "Fire condition".
- (iv) In case of dry pilot detection system, open the air supply valve to build-up air pressure as shown in TABLE-1. Open the priming valve fully and press hold the knob of PDA till the water pressure gauge indicate full service line pressure, then release the PDA knob. Open the upstream side of the stop valve provided below the deluge valve. No water should flow into the system, this can be checked by depressing the drip check valve knob.

CAUTION

- (a) Do not close the priming valve, down stream and upstream stop valves, while the system is in service.



D-Pack Deluge Cabinet

- (b) The releasing device must be maintained in the open position, when actuated, to prevent the deluge valve from closure.

SYSTEM TESTING PROCEDURE

- (i) Keep the upstream side of the stop valve partially open. Open the upstream side of the drain valve, to maintain a minimum pressure of 3 Kg./sq. cm on the upstream side of the deluge valve. To avoid water damage close the system side stop valve. This valve is to be kept in open position after the testing is completed.
- (ii) Open the system side drain valve of the deluge valve.
- (iii) Let any of the release devices to trip. This will result in a sudden drop of water pressure in the deluge valve top chamber resulting the deluge valve to open. The water flowing through the down stream side drain valve confirms that the deluge valve has actuated, immediately close the upstream side stop valve .(iv) Once testing is over reset the valve as per procedure given under heading "RESETTING PROCEDURE FOR THE DELUGE VALVE".

INSPECTION AND MAINTENANCE

All the newly installed system piping network must be flushed properly before placing the deluge valve in service.

A qualified and trained person must commission the system. After few initial successful tests an authorised person must be trained to perform inspection and testing of the system. It is recommended to have regular inspection and test run the system as per NFPA guidelines or in accordance with the guideline laid down by the organisation having local jurisdiction.

(i) WARNING

Inspection and testing is to be carried out only by authorised and trained personnel. DO NOT TURN OFF the water supply or close any valve to make repair(s) or test the valve, without placing a roving fire patrol in the area protected by the system. Also inform the local security personnel and central alarm station, so that a false alarm is not signalled.

It is recommended to carry out physical inspection of the system at least twice in a week. The inspection should verify that all the control valves are in proper position as per the system requirement and no damage has taken place to any component.

(ii) NORMAL CONDITION

- (a) All main valves are open and are sealed with tamper proof seal.
- (b) Drain valves must be kept closed.
- (c) No leak or drip is detected from the drip valve.
- (d) All the gauges except the system side water pressure gauge, should show the required pressure.
- (e) There should be no leakage in the system.

(iii) NORMAL CONDITION TEST

- (a) The system should be checked for normal condition at least once a month.
- (b) Test the sprinkler alarm bell or electric alarm by turning the alarm test valve to the test position. The alarm should sound. This test should be carried out at least once in a week.
- (c) Depress the drip valve knob. Significant water accumulation indicates a possible seat leakage.
- (d) Conduct the water flow test as per the procedure of system testing at least once in a month.

(iv) PERIODIC CHECK

Conduct the water flow test by actuating few of the release devices provided in the system. Clean all strainer(s) and priming line restriction. This test is to be carried out at least once in six months.

ABNORMAL CONDITION

(i) ALARM FAILS TO SOUND

- (a) Check for any obstruction in the alarm test line, Ensure that the sprinkler alarm is freely operating.
- (b) If an electric alarm is provided, check the electrical circuitry to the alarm.

(ii) FALSE TRIPS

- (a) Check for clogging in priming line, restriction orifice check valve, priming valve & strainer.
- (b) Leakage in the release system.
- (c) The deluge air panel orifice clogged or low supply pressure.

(iii) LEAKAGE THROUGH THE DELUGE VALVE

- (a) Damaged deluge valve seat or obstruction on the seat face by foreign object.
- (b) Leakage in release system.
- (c) Partly clogged priming line, restriction check valve.
- (d) Low air pressure on release system line or leakage in release system.
- (e) PDA seat leakage due to seat damage or obstruction on seat face by foreign objects (in dry pilot system only)

NOTE

UL listing is valid only when Deluge Valve is installed with trim set as per trim drawing.

D-Pack Deluge Cabinet

DELUGE VALVE MODEL-A SIZE 150 / 100 / 80 / 50 NB

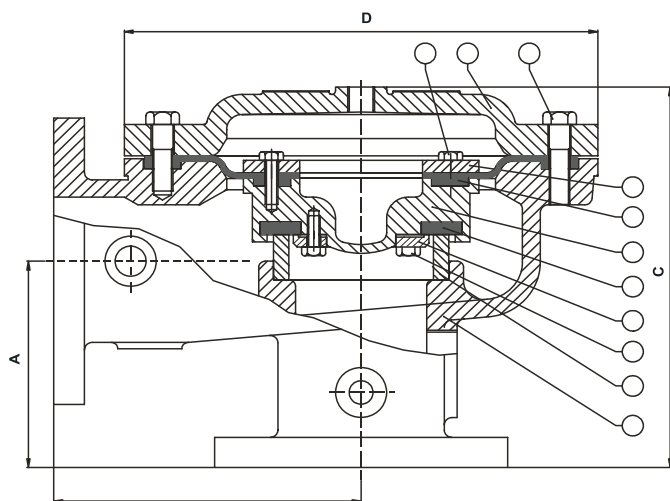

DIMENSION in millimeter [Approximate]

VALVE NOMINAL SIZE	'A'	'B'	'C'	'D'
150 NB	200	300	382	464
100 NB	165	240	304	370
80 NB	135	210	272	316
50 NB	135	210	272	316

PART LIST

ITEM	PART NO.				DESCRIPTION	QTY.				MATERIAL SPECIFICATION
	150 NB	100 NB	80 NB	50 NB		150 NB	100 NB	80 NB	50 NB	
1	2101	2121	2141	2161	HOUSING	1	1	1	1	CAST IRON
2	2107	2127	2147	2147	TSEA	1	1	1	1	CAST BRONZE
3	2105	2125	2145	2145	CLAPPER	1	1	1	1	CAST BRONZE
4	2109	2129	2149	2149	SEAT RUBBER	1	1	1	1	NEOPRENE
5	2110	2130	2150	2150	RUBBER CLAMP	1	1	1	1	CAST BRONZE
6	9102	9102	9102	9102	TBOL	4	4	3	3	STAINLESS STEEL
7	2108	2128	2148	2148	DIAPHRAGM	1	1	1	1	NEOPRENE
8	2106	2126	2146	2146	CLAMPING	1	1	1	1	CAST BRONZE
9	9105	9105	9105	9105	TBOL	12	8	8	8	STAINLESS STEEL
10	2104	2124	2144	2144	COVER	1	1	1	1	CAST IRON
11	-	-	-	-	BOLT	16	12	12	12	STEEL



D-Pack Deluge Cabinet

DELUGE VALVE CABINET SIZE 150 / 100 / 80 / 50 NB

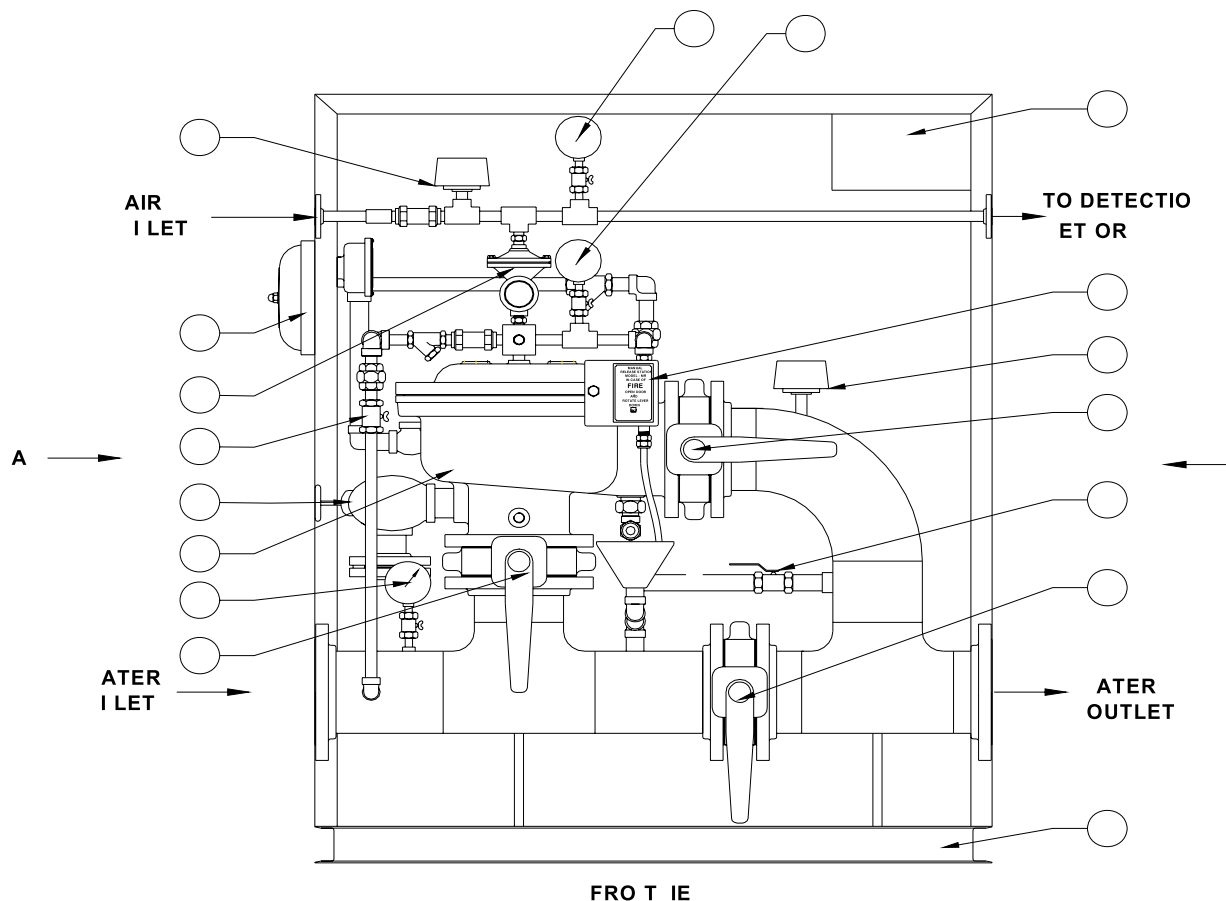

Sr.No.	Description
1	Frame
2	Upstream Valve (Normally Open)
3	Manual Valve (Normally closed)
4	Downstream Valve (Normally Open)
5	Sprinkler Alarm
6	Positive Drain Actuator(PDA)
7	Priming Valve (Normally Open)
8	Drain Valve (Normally closed)
9	System Drain Valve (Normally closed)
10	Water Header Presure Gauge
11	Pressure Gauge (System side)
12	Pressure Gauge (Air Detection Line)
13	Pressure Switch (System side)
14	Pressure Switch (Air Detection Line)
15	Emergency Release Station.
16	Junction Box

D-Pack Deluge Cabinet

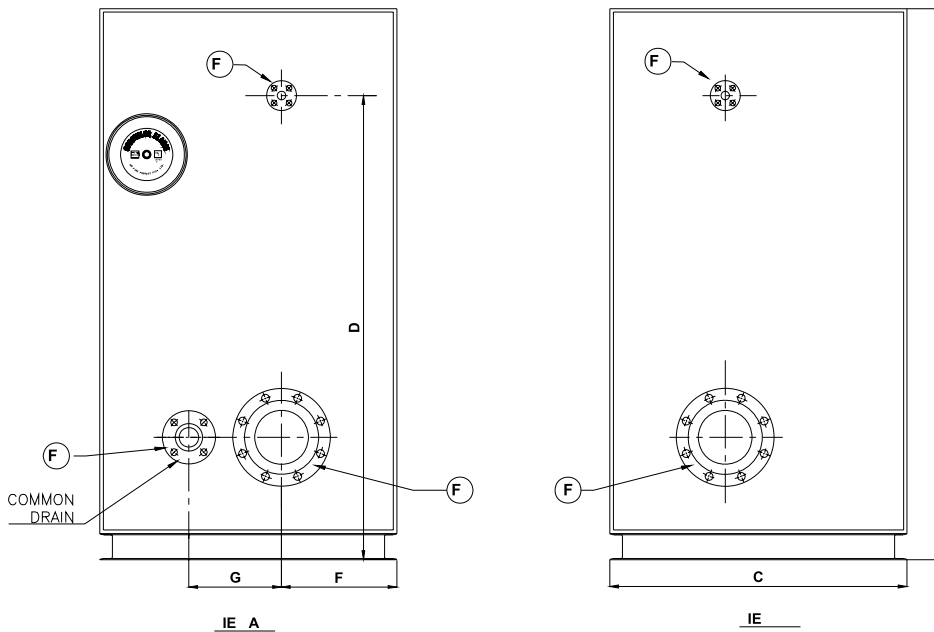
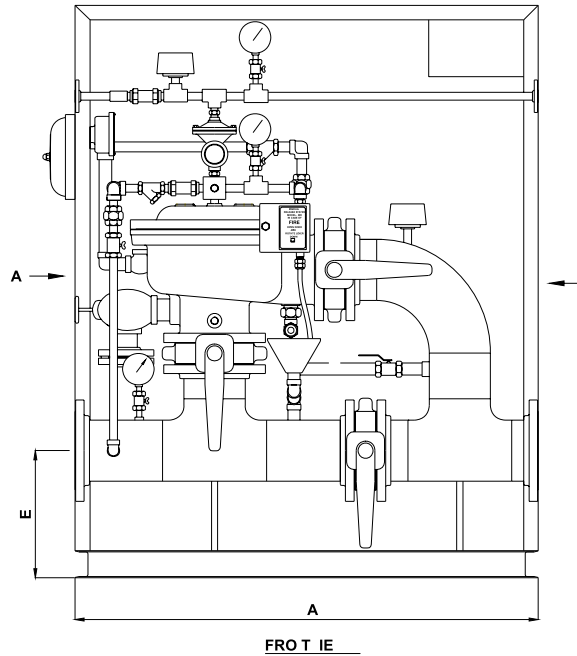

F1- Water inlet, F2- Water Outlet, F3 - Drain connection, F4- Air Inlet, F5- To Detection Network

DIMENSION in millimeter [Approximate]

SIZE	A	B	C	D	E	F	G
150	1275	1575	850	1325	350	330	265
100	1000	1500	750	1250	350	285	250
80/50	900	1425	700	1175	350	250	225



D-Pack Deluge Cabinet

ELECTRIC & HYDRAULIC RELEASE TRIM - SCHEMATIC
 DELUGE VALVE 150 / 100 / 80 / 50 NB A

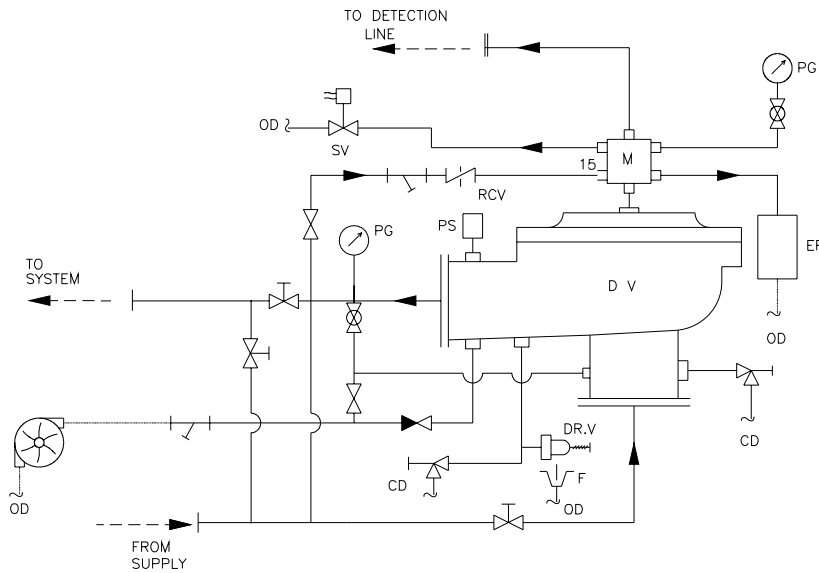

ELECTRIC & PNEUMATIC RELEASE TRIM - SCHEMATIC
 DELUGE VALVE 150 / 100 / 80 / 50 NB A

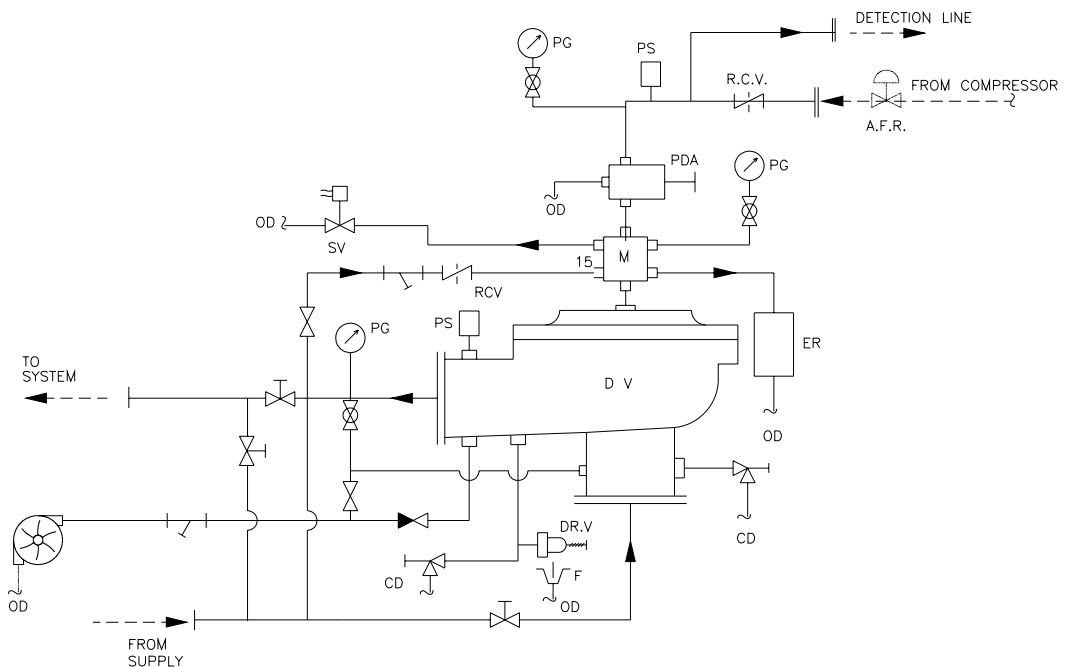

	ALE		STOP ALE		DR. DRIP ALE		O RETUR ALE
	STRAIER		Y USER		CD CO O DRAI		ER E ERGE CY RELESE O
	OPTIO AL		S SOLO OI D ALE		F FU EL		RC RESTRECTIO C EC ALE
	GAUGE ALE		PS PRESSURE SITC		D DELUGE ALE		PG PRESSUER GAUGE
	A GLE ALE		SI AY A IFOLD				

D-Pack Deluge Cabinet

WET PILOT SPRINKLER
HEIGHT LIMITATION OF 150NB

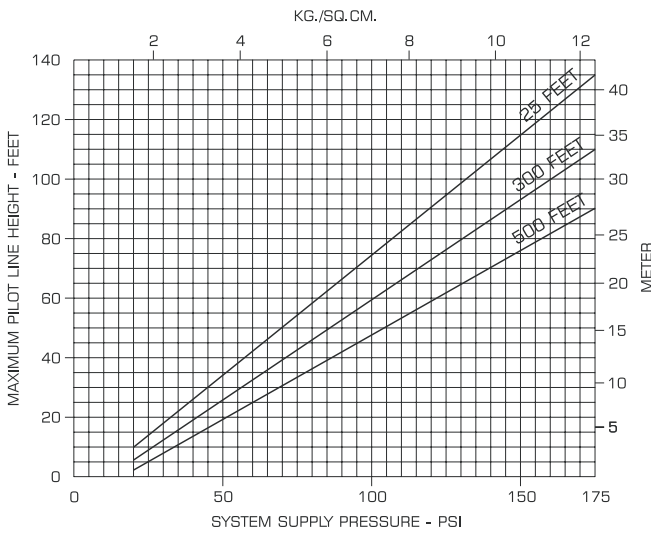

WET PILOT SPRINKLER
HEIGHT LIMITATION OF 100NB

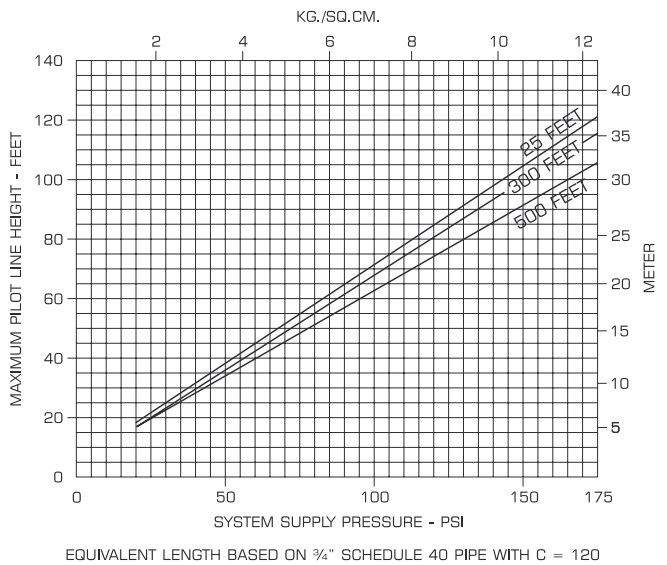
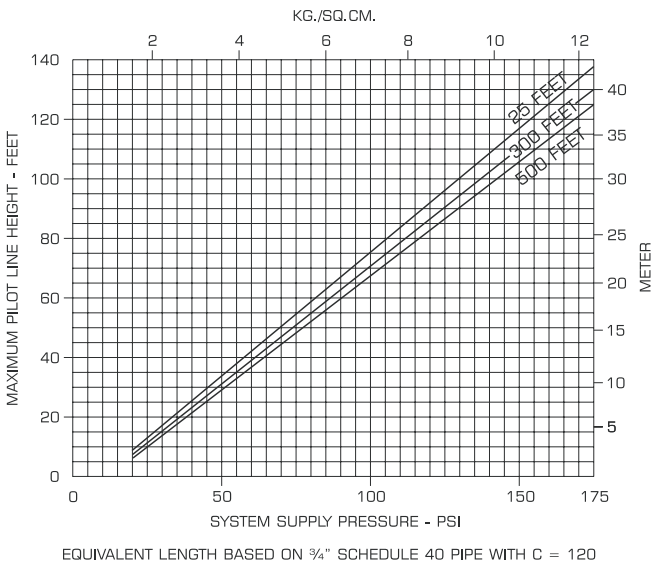
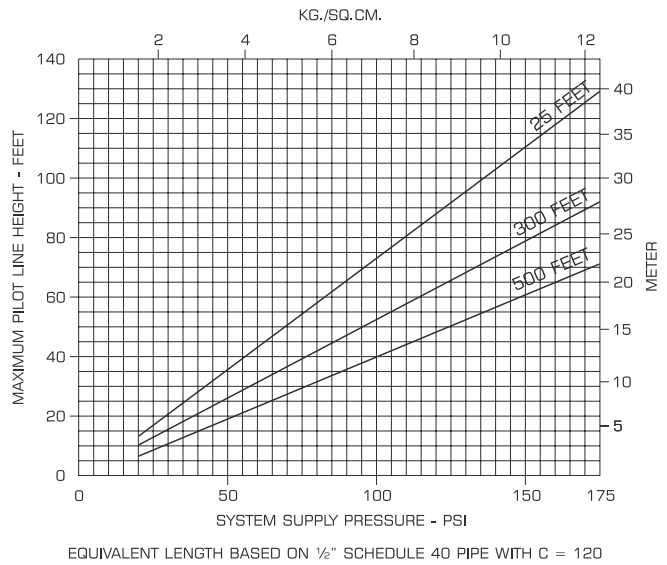



D-Pack Deluge Cabinet

WET PILOT SPRINKLER
 HEIGHT LIMITATION OF 80NB

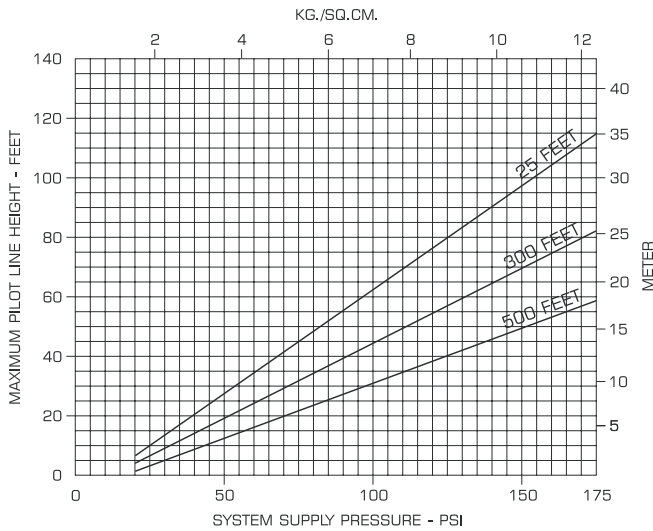

EQUIVALENT LENGTH BASED ON 1/2" SCHEDULE 40 PIPE WITH C = 120

WET PILOT SPRINKLER
 HEIGHT LIMITATION OF 50NB

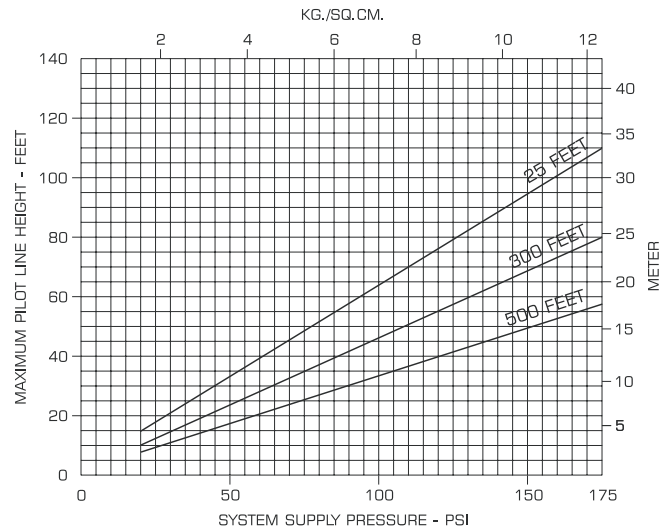

EQUIVALENT LENGTH BASED ON 1/2" SCHEDULE 40 PIPE WITH C = 120

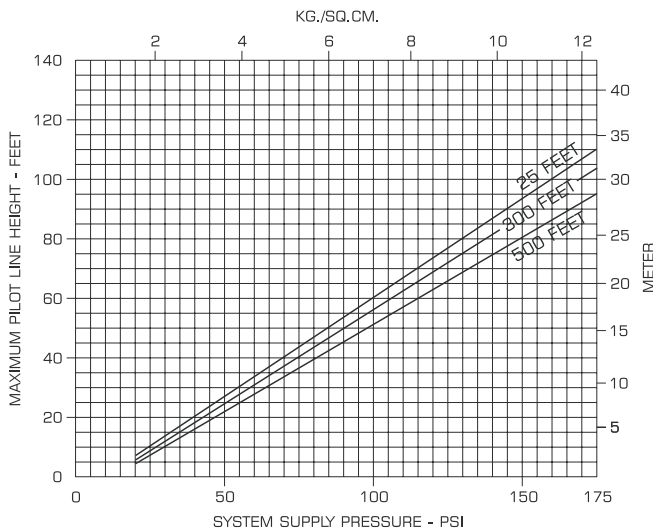

EQUIVALENT LENGTH BASED ON 3/4" SCHEDULE 40 PIPE WITH C = 120

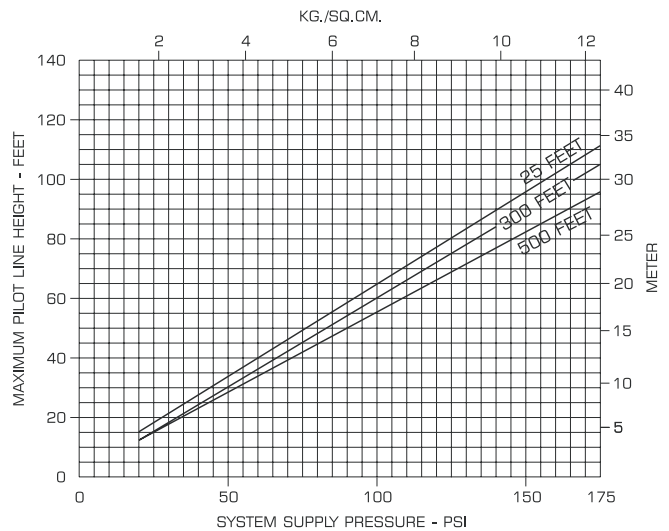

EQUIVALENT LENGTH BASED ON 3/4" SCHEDULE 40 PIPE WITH C = 120