

CRAB

Oil slicks optical detector

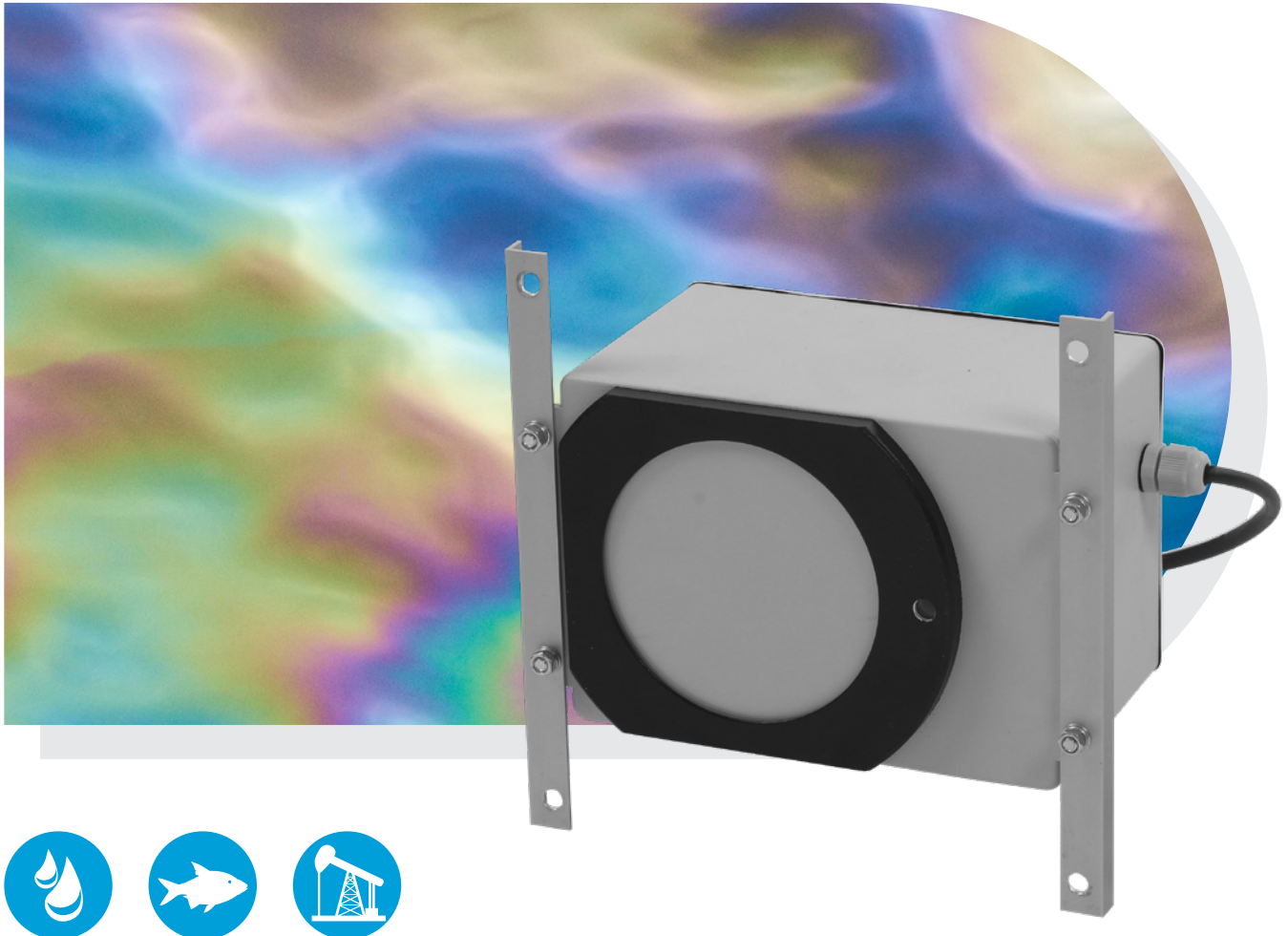

Method

Remote optical sensing of water surface with vertical laser beam

Principle of operation

Is based on the difference in light reflection from water and oil film surface

Applications

- Monitoring of water surfaces (sea, harbors, lakes, rivers)
- Oil leakage detection
- Monitoring of process and waste waters
- Stationary monitoring and mobile surveys

Features and benefits

- Continuous remote optical sensing, no sampling
- High sensitivity: detection of oil slicks with thickness down to 0.5 micron
- No interference from scattered radiation
- Low interference from ripples and waves (beam/surface angle up to $\pm 20^\circ$)
- Built-in data acquisition and processing
- Waterproof housing for outdoor installation
- Ex-proof option is available
- Mounting at stationary points, buoys, motor boats
- Long-term operation without maintenance

Specifications

| | |
|-----------------------------------|---|
| Detecting object | Oil slick on water surface |
| Min detectable oil film thickness | 0.5 μm |
| RMS slope of the water surface | up to 20 ° |
| Mode of measurement | Continuous |
| Min response time | 0.1 s |
| Signal status outputs | "No", "Yes" ("Alarm") |
| Communication ports | RS-485 Current loop 4–20 mA |
| Twisted pair length | up to 1500 m |
| Power supply | 100–240 V, 50–60 Hz |
| Power consumption | up to 3 W |
| Ambient conditions | Temperature: –10 to +50 °C Humidity: up to 100% (rain) |
| Distance to the water surface | 0.5–20 m |
| Dimensions | 120×180×120 mm |
| Weight | up to 1.5 kg |

Equipment and options

- CRAB optical detector
- Power supply unit for AC 110–240 V power mains (optional)

Warranty

CRAB optical detectors are covered by a 12-month warranty.

Service

Our engineers develop a scheme and design for the detectors installation upon customer's request and provide consultations and training.

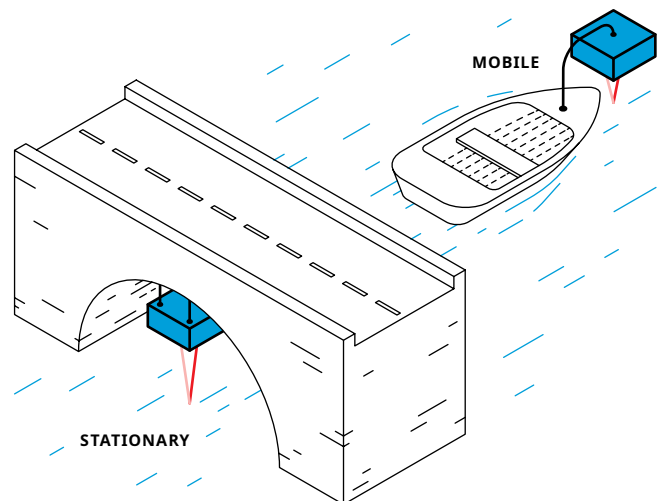

Find your local Lumex Instruments distributor

www.lumexinstruments.com

sales@lumexinstruments.com