

1 OVERVIEW

The ESD1000 Series Speed Control unit is an all-electronic device designed to control engine speed with fast and precise response to transient load changes. This closed-loop control, when connected to a proportional electric actuator and supplied with a magnetic speed sensor signal, will control a wide variety of engines in an isochronous mode. It is designed for high reliability and is hard-potted to withstand the engine environment.

- 12 or 24 V DC
- Simple, low-cost isochronous operation
- Gain adjustment
- Rugged, hard potted
- Terminal strip option available
- 12-pin AMP connector option available
- Flying Leads (ESD1000 only)



PRODUCT	SYSTEM VOLTAGE		CONNECTOR TYPE	
	12 V DC	24 V DC	Wire Leads	Terminal Strip
ESD1000-12	☑		☑	
ESD1000-24		☑	☑	
ESD1100-12				☑
ESD1100-24		☑		☑

2 SPECIFICATIONS

PERFORMANCE	
Isochronous Operation	± 0.25 % or better
Speed Range / Governor	1 - 7.5 KHz Continuous Ration 7:1
Speed Drift with Temperature	±1% MAX
Yellow Wire Sensitivity	130 Hz. ±15 Hz/Volt @ 5.1 K impedance
Speed Trim Range	± 250 Hz
RELIABILITY	
Vibration	5 G @ 20-500 Hz
Testing	Functionally Tested

INPUT / OUTPUT	
DC Supply	8-20 V DC (12 V DC Unit) 16-32 V DC (24 V DC Unit) Transient and Reverse Voltage Protected*
Polarity	Negative Ground (Case Isolated)
Power Consumption	60 mA continuous plus actuator current
Actuator Current @ 25°C (77°F)	10 A Peak
Speed Sensor Signal	1.0 - 120 V RMS
ENVIRONMENTAL	
Ambient Temperature	-40 °C to 85 °C (-40 °F to 180 °F)
Relative Humidity	up to 100 %
All Surface Finishes	Fungus-Proof and Corrosion-Resistant
PHYSICAL	
Dimension	See Section 3, INSTALLATION
Weight	12 ozf (347 gf)
Mounting	Any position, Vertical Preferred

* Reverse voltage is protected against by a parallel diode on the 12 V DC unit and a series diode on the 24 V DC unit. A 15 A fuse must be installed in the positive battery lead.

3 INSTALLATION



Vertical orientation allows for the draining of fluids in moist environments.



Mount in a cabinet, engine enclosure, or sealed metal box.



Avoid Extreme Heat

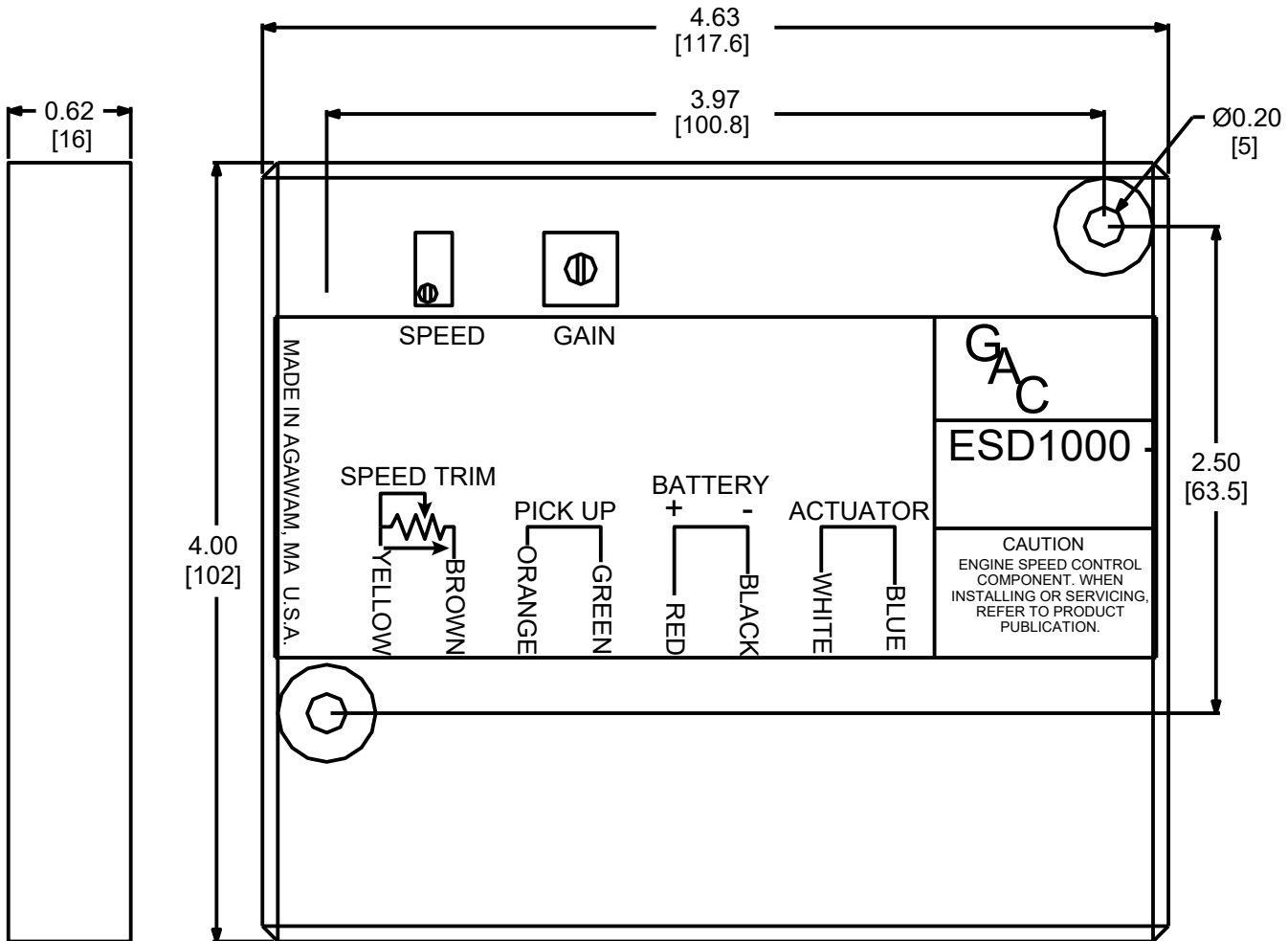

Dimensions:

in
[mm]

4 WIRING

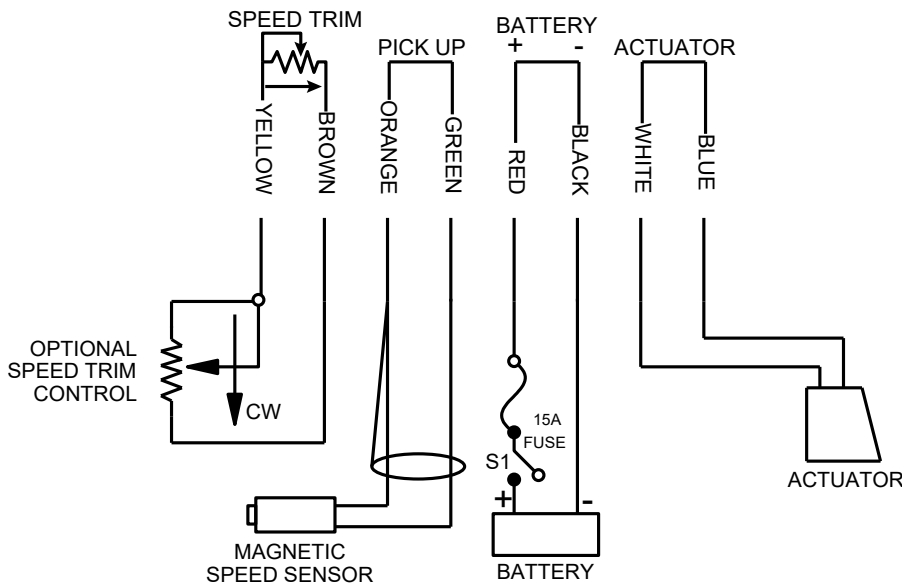

RECOMMENDATIONS

1. Use shielded cable for all external connections to the ESD control.
2. One end of each shield, including the speed sensor shield, should be grounded to a single point on the ESD case.

TERMINAL	DEFINITION	NOTES
Yellow	Speed Trim Control	Optional feature
Brown		
Orange	Magnetic Speed Pickup	<ul style="list-style-type: none"> • Wires must be twisted and/or shielded for their entire length. • Gap between speed sensor and gear teeth should not be smaller than 0.02 in. (.51 mm) • Speed sensor voltage should be at least 1 V AC RMS during crank
Green		
Red	Battery Power (+)	A 15 A fuse must be installed in the positive battery lead to protect against reverse voltage.
Black	Battery Power (-)	
White	Actuator	#16 (1.3 mm sq) or larger gauge
Blue		

5 STARTING THE ENGINE

Make the following adjustments to Gain and Speed Trim before starting the engine.

Gain	Middle Position
Speed Trim Control	Middle Position

The speed control unit governed speed setting is factory set at approximately engine idle speed. (1000 Hz., Speed sensor signal or 600 RPM)

Crank the engine with DC power applied to the governor system. The actuator will energize to the maximum fuel position until the engine starts. The SPEED adjust pot is a 25-turn pot and you may have to turn it clockwise several turns before the engine starts.

Once the engine starts, the governor system should be controlling the engine at a low idle speed. If the engine is unstable after starting, turn the GAIN adjustment counterclockwise until the engine stabilizes.

NOTE

The governed speed setpoint is increased by clockwise rotation of the SPEED adjustment control. Remote speed adjustment can be obtained with an optional Speed Trim Control.

6 ADJUSTING FOR STABILITY

Once the engine is at operating speed and at no-load, the following governor performance adjustments can be made:

START FUEL ADJUSTMENT

1. Rotate the GAIN adjustment clockwise until instability develops. Gradually move this adjustment counterclockwise until stability returns. Move this adjustment 1/8 of a turn further counter-clockwise to ensure stable performance (270° potentiometer).
2. Gain adjustments may require minor changes after engine load is applied. Normally, adjustments made at no-load achieve satisfactory performance. A strip chart recorder can be used to optimize the adjustments further.
3. If instability cannot be corrected or further performance improvements are required, refer to the Troubleshooting section.

7 SYSTEM TROUBLESHOOTING

SYSTEM INOPERATIVE

If the engine governing system does not function, the fault may be determined by performing the voltage tests described in Steps 1 through 4. Positive (+) and negative (-) refer to meter polarity. Should normal values be indicated during troubleshooting steps, and then the fault may be with the actuator or the wiring to the actuator. Tests are performed with battery power on and the engine off, except where noted. See actuator publication for testing procedure on the actuator.

STEP	WIRES	NORMAL READING	PROBABLE CAUSE OF ABNORMAL READING
1	Red(+) & Black(-)	Battery Supply Voltage (12 or 24 V DC)	<ol style="list-style-type: none"> 1. DC battery power not connected. Check for blown fuse, switch off power. 2. Low battery voltage 3. Wiring error
2	Yellow(+) & Brown(-)	0-2.5 V DC with speed trim 4.7-5.4 V DC without speed trim	<ol style="list-style-type: none"> 1. Speed trim shorted or mis-wired. 2. Defective unit.
3	Orange(+) & Green(-)	1.0 V AC RMS min. while cranking	<ol style="list-style-type: none"> 1. Gap between speed sensor and gear teeth too great. Check Gap. 2. Improper or defective wiring to the speed sensor. Resistance between D and C should be 160 to 1200 Ω. See specific mag pickup data for resistance. 3. Defective speed sensor.
4	Red(+) & Blue(-)	0.8-1.5 V DC while cranking	<ol style="list-style-type: none"> 1. Wiring error to actuator. 2. Defective speed control unit. 3. Defective actuator.

INSTABILITY

INSTABILITY	SYMPTOM	PROBABLE CAUSE OF ABNORMAL READING
Fast Periodic	The engine seems to jitter with a 3 Hz or faster irregularity of speed.	<ol style="list-style-type: none"> 1. Readjust the Gain and Stability for optimum control. 2. Turn off other electrical equipment that may be causing interference.
Slow Periodic	An irregularity of speed below 3 Hz.	<ol style="list-style-type: none"> 1. Readjust the Gain 2. Check fuel system linkage during engine operation for: <ol style="list-style-type: none"> a. binding b. high friction c. poor linkage 3.
Non-Periodic	Erratic Engine Behavior	<ol style="list-style-type: none"> 1. Increasing the Gain should reduce the instability but not totally correct it. If this is the case, there is most likely a problem with the engine itself. Check for: <ol style="list-style-type: none"> a. engine mis-firings b. an erratic fuel system c. load changes on the generator set voltage regulator.

If unsuccessful in solving instability, contact GAC for assistance.
GAC@governors-america.com or call: 1-413-233-1888

UNSATISFACTORY PERFORMANCE

SYMPTOM	NORMAL READING	PROBABLE CAUSE OF ABNORMAL READING
Engine Overspeeds	1. Do Not Crank. Apply DC power to the governor system.	1. After the actuator goes to full fuel, disconnect the speed sensor at Orange and Green wires. If the actuator is still at full fuel-speed then the speed control unit is defective. 2. If the actuator is at minimum fuel position and there exists an erroneous position signal, then check speed sensor cable.
	2. Manually hold the engine at the desired running speed. Measure the DC voltage between the Blue wire(-) and the RED wire(+) on the speed control unit.	1. If the voltage reading is 1.0 to 1.5 VDC: a. Speed adjustment is set above desired speed b. Defective speed control unit 2. If voltage reading is above 1.5 VDC then check for: a. actuator binding b. linkage binding 3. If the voltage reading is below 0.8 VDC: a. Defective speed control unit
Actuator does not energize fully while cranking	1. Measure the DC voltage between BLUE wire(-) and RED wire(+) on the speed control unit. Should be 0.8 to 1.5 volts. If not:	1. Actuator wiring incorrect 2. If the voltage is less than: a. 7V for a 12V system, or b. 14V for a 24V system, Then: 3. Check or replace battery.
	2. Momentarily connect BLUE wire to the RED wire. The actuator should move to the full fuel position.	1. Actuator or battery wiring in error 2. Actuator or linkage binding 3. Defective actuator
Engine remains below desired governed speed	1. Measure the actuator output, WHITE and BLUE, while running under governor control.	1. If voltage measurement is within 1.5 VDC of the battery supply voltage level, then fuel control is restricted from reaching full fuel position, possibly due to mechanical governor, carburetor spring, or linkage interference. 2. Speed parameter set too low

INSUFFICIENT MAGNETIC SPEED SIGNAL

A strong magnetic speed sensor signal will eliminate the possibility of missed or extra pulses. The speed control unit will govern well with a 0.5 VAC RMS speed sensor signal. However, a speed sensor signal of 3 VAC RMS or greater is recommended.

The amplitude of the speed sensor signal can be raised by reducing the gap between the tip of the speed sensor and the top land of a tooth on the engine's ring-gear. This gap should not be any smaller than 0.020 in. (0.45 mm). With the engine stopped, turn the magnetic speed sensor CW until it touches the top land of a ring-gear tooth, then turn it CCW 3/4 turn. This will provide an acceptable gap.