

EEG6500

Enhanced Electronic Governor

With Quikset Display

+1 413 233 1888

www.governors-america.com

1 INTRODUCTION

GAC's **EEG6500 Series Enhanced Electronic governor** is designed to regulate engine speed on diesel and gasoline reciprocating engines. With flexibility, precision, and accurate control of governed speed, the EEG is designed for industrial engine applications from generator sets and mechanical drives, to pumps or compressors.

The EEG6500 Series Quikset Display allows its operator to monitor and configure parameters without needing configuration software or a PC.

- Simple LCD User Interface; No potentiometer, No PC required
- 2 Fixed (Rated, Idle) and Variable Speed; Selectable Isochronous, Droop, & Variable Governing
- 5K Ω resistive, 0-5 V or 4-20 mA Variable Speed Input
- Speed Range to 12 KHz (6000 RPM) with Frequency Display
- Speed Ramping (Any Transient Speed Change)
- Standard GAC AUX Input for Synchronizing and Load Sharing
- Fault Protection with Overcurrent Sensing
- Adjustable Starting Fuel Strategy (Black Smoke Reduction)
- J1939 Engine Speed Output
- Compatible with all GAC actuators except ATB T4 Series, ADB335 and ACB2001.



2 SPECIFICATIONS

PERFORMANCE	
Isochronous Operation	$\pm 0.25 \%$
Speed Range / Governor	100 Hz - 12 kHz (200-6000 RPM w/ 120 tooth flywheel) continuous
Idle Adjust	Up to 1500 RPM
Droop Range	1 - 25 % regulation
Speed Trim	Programmable ± 120 Hz
INPUT / OUTPUT	
Supply	12-24 V DC Battery Systems (7.0 to 32.0 V DC)
Polarity	Negative Ground (Case isolated)
Power Consumption	70 mA MAX continuous plus actuator current
Speed Sensor Signal	1.0 - 60.0 V RMS
Actuator Current @ 77 °F [25 °C] MAX	10 A
Load Share/ Synchronizer Input	0-10 V DC (5 V nominal, reversed polarity, 145 Hz / V)
Reverse Power Protection	Yes
Transient Voltage Protection	60 V

ENVIRONMENTAL	
Ambient Temperature	-40 to 185 °F [-40 to 85 °C]
Relative Humidity	up to 95 %
All Surface Finishes	Fungus Proof and Corrosion Resistant
PHYSICAL	
Dimension	See Section 3 , Installation
Weight	1.8 lbf (820 gf)
Mounting	Any position, Vertical Preferred
RELIABILITY	
Vibration	7 G, 20-100 Hz
Shock	20 g Peak
Testing	100 % Functional Test
COMPLIANCE / STANDARDS	
Agency	CE, (EN55011, EN50081-2 and EN50082-2)
Communications	SAE J1939 (Optional)

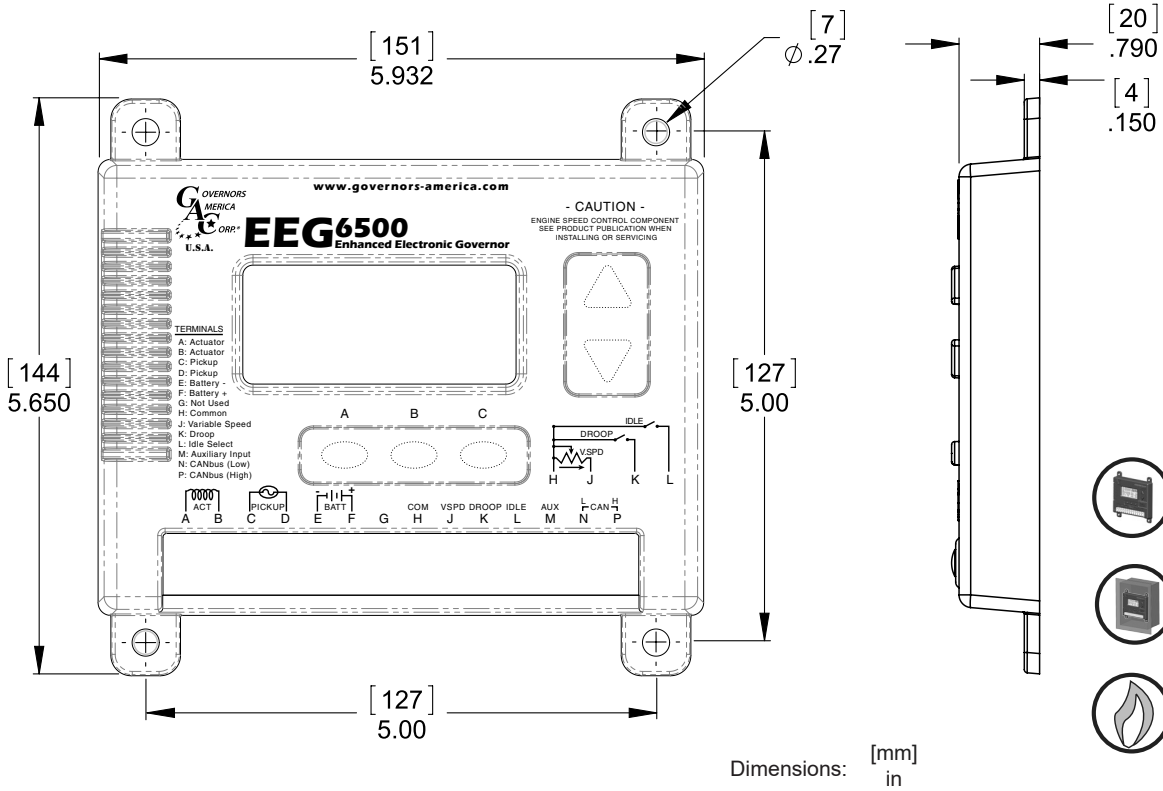

- Vertical orientation allows for the draining of fluids in moist environments.
- Mount in a cabinet, engine enclosure, or sealed metal box.
- Avoid Extreme Heat

Dimensions: [mm]
in



An overspeed shutdown device, independent of the governor system, must be provided to prevent loss of engine control which may cause personal injury or equipment damage. Do not rely exclusively on the governor system electric actuator to prevent overspeed.

A secondary shutoff device, such as a fuel solenoid must be used.

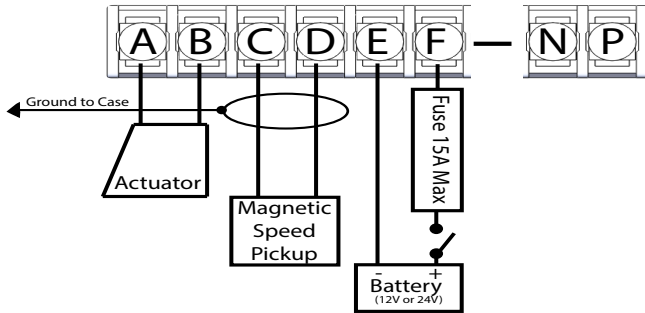

0 - 5 V OR 4-20 MA* VARIABLE SPEED INPUT

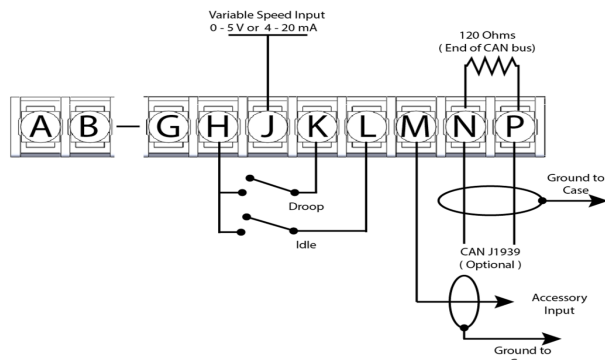

5 K Ω RESISTIVE SPEED TRIM POT

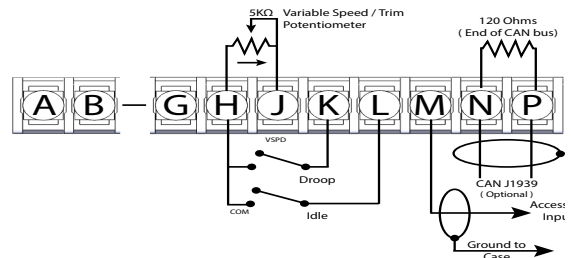

* 4-20mA input requires an external 200 Ω resistor across Terminals H & J



If EEG detects no input from the magnetic pickup, the EEG will set the actuator to 0 V and set the speed to 0 RPM. The display will flash the RPM along with the Warning Indicator. Parameters will be unchangeable.

IMPORTANT

When installing controller be sure there's a good connection between the case of the EEG6500 and the chassis / battery ground.

TERMINAL	DEFINITION	GAUGE / mm ²	NOTES
A	Actuator (+)	#16 / 1.31	
B	Actuator (-)	#16 / 1.31	
C	Magnetic Pickup (+)	#20 / 0.52	* Twisted wires 14 turns per foot. 0.02 in (.51 mm) gap between sensor and gear teeth.
D	Magnetic Pickup (-)	#20 / 0.52	
E	Battery (-)	#16 / 1.31	
F	Battery (+)	#16 / 1.31	A 15 A fuse must be installed in the positive battery lead to protect against any overload or short circuit
H	Ground Signal	#16 / 1.31	Reference for variable speed/trim input & switches
J	Variable Speed Input	#20 / 0.52	5K Ω Resistive, 0 - 5 V DC or 4-20 mA. Increasing voltage or resistance of current increases speed
K	Droop Select	#16 / 1.31	Active when connected to Terminal H
L	Idle Select	#16 / 1.31	Active when connected to Terminal H
M	Aux Input	#20 / 0.52	Load sharing / synchronizing, 5 V nominal (0-10 V), reverse ramp
N	CAN L	#20 / 0.52	Twist wires 14 turns per foot.
P	CAN H	#20 / 0.52	

RECOMMENDATIONS

1. Shielded cable should be used for all external connections to the EEG control. One end of each shield, including the speed sensor shield, should be grounded to a single point on the EEG case.
2. Case should be grounded

5 DISPLAY & CONTROLS

PARAMETER VALUE

Displays the value of a selected parameter or live running parameter. This area will blink if a system shutdown and restart is required.



PARAMETER UNITS

Displays the units for the parameter (e.g. RPM)



SECONDARY PARAMETERS

Pressing UP or DOWN arrow toggles through the five secondary parameters: Engine Speed (RPM), Duty Cycle (%), Actuator Current (Amps), Engine Speed (Hz) and Variable Speed (%)

OVERCURRENT

If the EEG detects an actuator overcurrent it will terminate power to the actuator, the display will flash Actuator Current along with the warning indicator. (Cycle power to restart)



FUEL LIMIT

If the EEG detects that the FUEL LIMIT setting has been exceeded, the display will flash the FUEL LIMIT along with the warning indicator. Parameters will be unchanged.



OVER SPEED

OVER SPEED will blink when the unit is in over-speed. (Cycle power to restart)

OVER SPEED

LOCK

Once the LOCK parameter on the main menu is enabled (ON), the display can be manually unlocked.

SPEED RAMP V.SPEED LOCKED ← Row 2 Column 3

Locking/Unlocking the Display

Press and hold both the UP and DOWN arrows simultaneously for 3 seconds to UNLOCK or to LOCK the display.



QUIKSET MENU

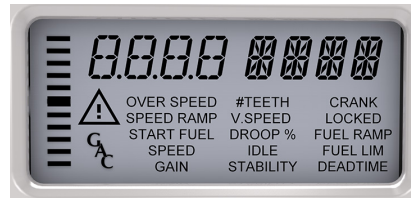

One row of parameters is displayed at a time.

PARAMETER ADJUST

Parameter Adjust Up

Increment a Parameter Value:

HOLD and TAP or



Rapidly Increment a Value:

HOLD and HOLD or

Lock the Display:

HOLD and for 2 seconds

Parameter Adjust Down

Unlock Display:

HOLD and for 10 seconds

COLUMN SELECT BUTTONS

1 2 3



To change the displayed row of parameters:

Tap any

To view a parameter value in a selected row:

Hold

For: SPEED Hold: Button 1

For: IDLE Hold: Button 2

For: FUEL LIM Hold: Button 3

END USER INTERFACE

PRIMARY PARAMETER VALUE (Blinks if restart required)

PRIMARY PARAMETER UNITS

PRIMARY PARAMETER (UNITS)

- Engine Speed (RPM)
- Duty Cycle (%)
- Actuator Current (A)
- Engine Speed (Hz)
- V-Speed (%)

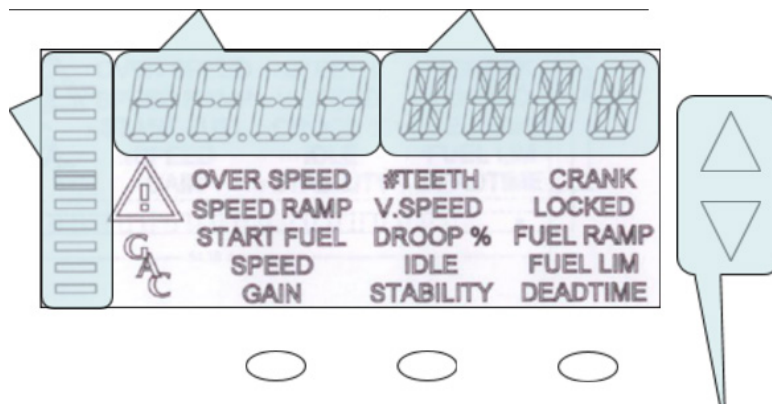

SECONDARY PARAMETER

ACTUATOR DUTY CYCLE

100 % = 11 Bars
90 - 99 % = 10 bars

...
10-19% = 2 bars
1 - 95 % = 1 bar
0 % = 0 bars

ENGINE SPEED RELATIVE TO SET POINT

Middle bar = set point
Top bar = Set point + 10 RPM
Bottom bar = set point - 10 RPM

Press UP or DOWN arrow to move the primary and secondary parameters to the next parameter set. The list scrolls in one direction.

TRIM or VARIABLE SPEED OPERATION

Trim Function - Performs finer adjustments (e.g. generator frequency) The resistive input speed function is active when the VSPD (Variable Speed) parameter is OFF (default value is OFF). 5K Ω potentiometer typical.

Variable Speed Function - Operates over a larger RPM range. Variable speed 0 - 2.5 volt input to terminal J is active when VSPD (Variable Speed) parameter is ON.

SPECIAL MENU PARAMETER			QUIKSET MENU PARAMETERS
VSPD	MODE	SPEED	V. SPEED
OFF	Trim (Default)	Application Rated Speed (e.g., 1500 RPM)	Speed Trim (10 = \pm 10 Hz)
ON	Variable Speed	Minimum speed when potentiometer is at lowest resistance (e.g., 1000 RPM)	Maximum Speed when potentiometer is at the highest resistance (e.g., 2000 RPM)

Variable Speed Input Signal, the controller accepts Resistive, Current and Voltage input signals selected from the VSMD parameter on the Advanced Menu page.

Variable Speed Response to External Voltage Input Variable Speed Parameter (VSPD)- ON, 5 K Potentiometer Between Terminal H & J Configured for 900 to 1800 RPM.

- **Current Input:** (Select CUR) Add an external 200 Ω resistor across Terminals H and J for a 4-20 mA input signal. The SPEED parameter sets the low speed at 4 mA, V.SPEED parameter sets the high speed at 20 mA. If the input current drops below 4 mA, variable speed will be clamped at 0 %. If the input current level exceeds 20 mA, variable speed will be clamped at 100 %. RPM response to current is linear.
- **Voltage Input:** (Select 5dc) voltage to 4.25 V, above 4.25 V the variable speed function will be clamped at 100 %, RPM response to voltage is linear.
- **Resistive Input:** (Select rES) Connect a 5K potentiometer between Terminals H and J. Maximum operating voltage is 5.0 V DC, response to this input is slightly non-linear.

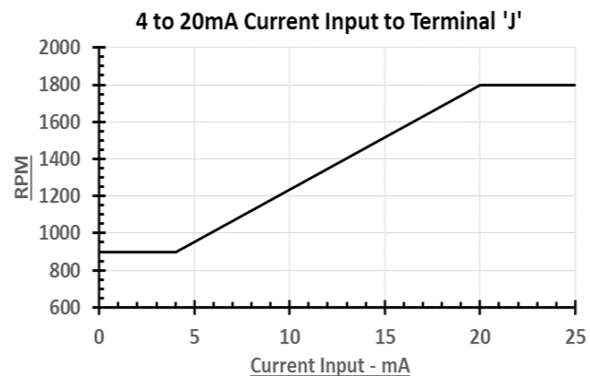
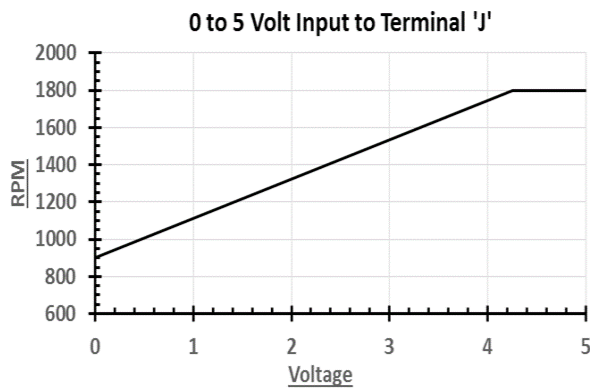

IMPORTANT

Increasing voltage or resistance increases speed.

POTENTIOMETER, VOLTAGE OR MILLIAMP INPUT TO TERMINAL J

Conversion Formulas:

$$\text{Hertz}_{\text{MAG PICKUP}} = \frac{(\text{RPM} \times \# \text{ Teeth})}{60\text{sec}}$$

$$\text{RPM} = \frac{(\text{Hertz}_{\text{MAG PICKUP}} \times 60\text{sec})}{\# \text{ Teeth}}$$

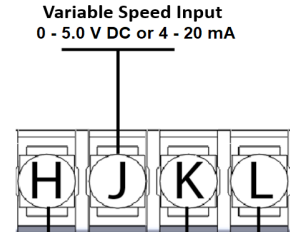
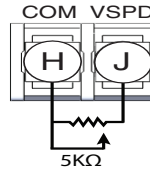

4 - 20 mA input requires an external 200 Ω resistor across Terminals H & J

LIGHT FORCE GOVERNOR

Turning the Light Force Governor, (LFG) feature ON (default is OFF) scales the governor's proportional response (GAIN) for the best resolution when controlling small actuators, including the **ATBT1, ALR, ALN, 100, 103, or 104** series and normally closed Cummins EFC actuators. Turn the LFG feature ON for use with these low current actuators.

The letters LFG display in place of the Primary Parameter Units when adjusting GAIN and STABILITY to indicate the feature is ON. The LFG Feature can only be turned ON or OFF when the engine is not running.

LEAD CIRCUIT

Turning the Lead Circuit (LEAD) ON (default is ON) enables the governor to be more responsive and typically increases the range of GAIN adjustment. Turn Lead Circuit ON when there is slow or moderate hunting at higher GAIN settings.

IDLE SPEED

The optional external switch must be connected between Terminals H and L. A pressure switch may also be used as a method of enabling. When enabled, IDLE has an independent Gain adjustment.

AUXILIARY INPUT

The Auxiliary (Aux) input, terminal M, accepts signals from auto synchronizers, load sharing units, and other GAC accessories.

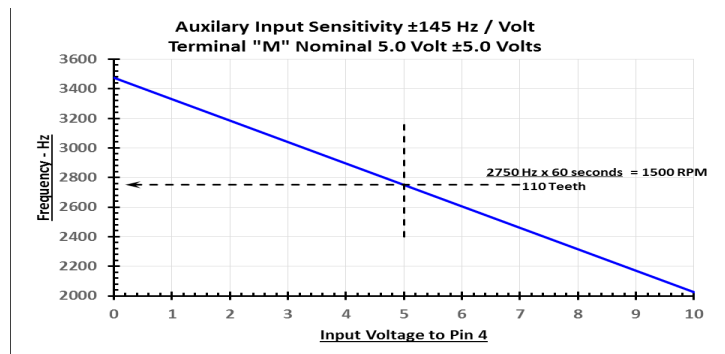

Set the following parameters before starting the engine:

#TEETH	Input the Number of Teeth on the Flywheel. This can not be changed while engine is running.
CRANK	Input the Crank Termination (RPM)
SPEED	Input the Fixed Speed of the Engine (RPM)

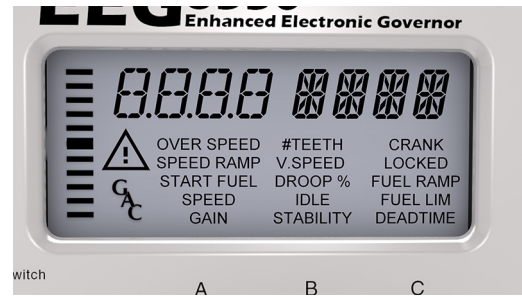

ADJUSTABLE QUICKSET PARAMETERS		
OVER SPEED *	#TEETH	CRANK *
Range: 400 - 6000 RPM Default: 2000 RPM	Range: 60 - 250 Default: 120	Range: 100 - 1000 RPM Default: 400 RPM
RPM to automatically shutoff the actuator	Number of teeth on flywheel	RPM which EEG switches from starting fuel limit to fuel limit
SPEED RAMP	V.SPEED *	LOCKED
Range: 25 - 2000 Default: 300	Range: 0-6000 RPM (vspd) 0-120 Hz (trim) Default: 1800 RPM (vspd) : 0 Hz (trim)	Range: OFF, ON Default: OFF
Rate at which speed changes from idle to set speed and back, or rate change in variable speed mode.	Maximum speed change allowed from trim input	Enables Manual/Auto locking of display. Press and hold UP and DOWN arrows simultaneously for 3 seconds to UNLOCK or LOCK the display.
START FUEL	DROOP%	FUEL RAMP
Range: 0 - 100% Default: 100%	Range: 0 - 25.0% Default: 5.0%	Range: 1 - 100% / Sec. Default: 10%
Initial actuator position at the start of cranking	Droop to apply under maximum load (based on current of actuator)	Actuator position increase in percent per second from cranking to low idle speed, starting from the Start Fuel position
SPEED *	IDLE *	FUEL LIM
Range: 0-6000 RPM (fixed) 0-6000 RPM (droop) Default: 1500 RPM (fixed) 50 RPM (droop)	Range: 150 - 1500 RPM Default: 900 RPM	Range: 0 - 100% Default: 100%
Operating speed of engine	Speed of engine when IDLE input is closed	Maximum actuator percentage allowed
GAIN	STABILITY	DEADTIME
Range: 1 - 100, 100 = Max Gain Default: 50 (rated) : 10 (idle)	Range: 1 - 100, 100 = fastest response Default: 50	Range: LOW, HI Default: HI
Proportional (P) set point of the PID control at operating SPEED and IDLE	Integral (I) set point of the PID control	Derivative (D) set point of the PID control

* 12 kHz MAX

8

ADJUSTING FOR STABILITY

Once the engine is running at operating speed and at no load, the following governor performance adjustments can be made to increase engine stability.

GAIN - RATED SPEED & IDLE SPEED

The EEG6500 is equipped with two separate gains, one for rated speed, the other for idle speed. Both are set using the GAIN setting on the Quikset Menu.

GAIN TYPE	ADJUSTMENT PROCEDURE	
RATED SPEED	1.	Selected when IDLE input is disconnected.
IDLE SPEED	1. 2. 3.	Connect the idle input to ground. Change GAIN value. Disconnect Idle input from ground to switch back to Rated. Idle icon will blink.

QUIKSET MENU

PARAMETER		ADJUSTMENT PROCEDURE	
A.	GAIN	1. 2. 3. 4.	Increase this parameter until instability develops. Then, gradually decrease this parameter until stability returns. Finally, decrease this parameter one increment further to ensure stable performance. If instability persists, adjust the next parameter.
B.	STABILITY	1. 2.	Follow the same adjustment procedure as the GAIN parameter. If instability persists, adjust the next parameter.
C.	DEADTIME	1.	If fast instability occurs, switch DEADTIME to low and repeat steps A & B.

NOTE

Normally, adjustments made at no load achieve satisfactory performance. For further performance see the System Troubleshooting section.

9

ADJUSTING FOR DROOP

After the initial set up is completed and the # of Teeth, Crank Termination Speed and Rated Speed are set, position the external switch connecting Terminals H and K on to activate the DROOP mode following these sequence steps.

1. On the EEG, press and hold all three buttons simultaneously for two seconds to switch to Advanced Menu.
2. Confirm that the VSPD (Variable Speed / Fixed Speed Control) is OFF. Default position is off.
3. Confirm that the LEAD circuit is OFF. Default position is on.
4. Set the NLCU (No Load Current) to the measured / displayed current value when operating at no load rated speed (default value is 0.5 amps.)
5. Set the FLCU (Full Load Current) to the measured / displayed current value when operating at full load rated speed (default value is 4.0 amps.)
6. Return to the Main Menu: Press and hold all three buttons simultaneously for two seconds to switch to the Main Menu.
7. Select and set DROOP to the desired percentage.
8. Change the Speed parameter, this now displays DROOP OFFSET. This sets the RPM, above operating speed; this is used when DROOP is enabled. This is an offset value.

1500 RPM operating speed x 0.05 (5.0% droop) = 75 RPM Input 75 RPM, this is the offset value.

EXAMPLE

The **NLCU** entered must be less than the **FLCU** and the difference between the two must be at least 0.5 A. If an invalid combination is entered a warning will be flagged and the parameters will be default to 0.5 A and 4.0 A.

10 ADVANCED PARAMETERS MENU

Display Special Menu Parameters:

Hold ALL 3  until AUX appears in display

1. After 3 minutes of no user input, EEG switches to Quikset Menu.
2. Lock is displayed when attempt to change a Read-Only parameter.

Selecting Parameters:

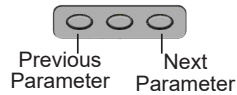

Adjust Parameters:

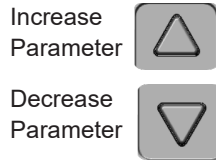

Return to Quikset Menu:

Hold ALL 3  for 2 seconds

EEG6500 - Variable Speed Response to External Voltage Input Variable Speed Parameter (VSPD) - ON

0 to 5 Volt Input to Terminal 'J'

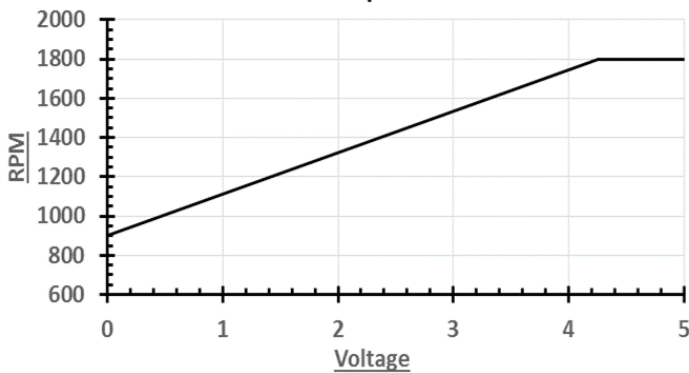

4 to 20mA Current Input to Terminal 'J'

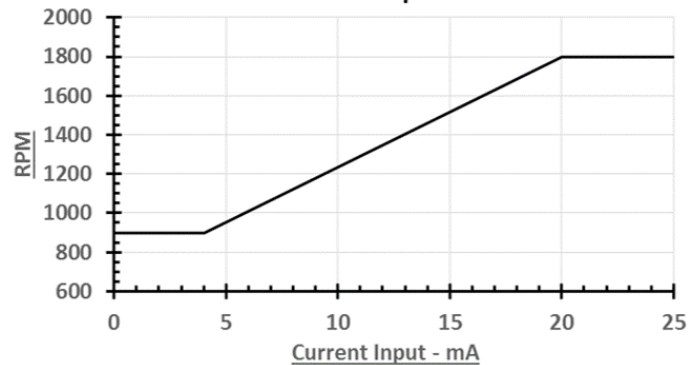

ADVANCED MENU PARAMETERS (READ ONLY)

Parameter	Definition
SREV	Software revision number
BID	Software build identifier
AREV	Assembly revision: Identifies board hardware configuration, not software.
FLTH	Highest fault code since power up. Aids in trouble shooting.
DATL	Supplemental data associated with last fault code. Aides in troubleshooting.
FLTL	Last fault code detected. Associated data is DATL and aids in trouble shooting.

ADVANCED MENU PARAMETERS (CONFIGURABLE)

Parameter	Definition	Range	Default
AUX	Auxiliary Input Enable 145 Hz/volt, 5 volt nominal Range: 1-9 V	Off, On	Off
VSPD	Variable Speed or Trim Select (On=Variable Speed, Off=Trim)	Off, On	Off
LFG	Light Force Governor	Off, On	Off
LEAD	Lead Circuit - For Increased Governor Response / Increased GAIN Adjustment Authority.	Off, On	On
NLCU	No Load Current - Amps	0.0 - 9.5	0.5
FLCU	Full Load Current - Amps	0.5 - 10.0	4.0

10 ADVANCED PARAMETERS MENU (CONTINUED)

OEM SAVE SETTINGS

OEM SAVE copies the currently active settings into separate OEM configuration area that can be restored at a later date.

OEM SAVE

Displays "SAVE" when data has been saved

Press LEFT, RIGHT, and DOWN Buttons simultaneously and hold until "SAVE" is displayed (about 10 seconds)

OEM RESTORE

OEM RESTORE copies the settings stored from the OEM configuration area into the current settings and saves them for next power up. After restoration, unit must be repowered to start engine. OEM Restore can only be done during power up.

OEM RESTORE

Displays "OEM" when settings have been restored successfully into current user settings. Repower unit to start.

Displays "FAIL" when error occurred restoring settings from OEM area. Unit tries to restore from user settings, if unsuccessful, factory settings restored. Repower unit to try again.

During Power Up, Press LEFT, RIGHT, and DOWN Buttons simultaneously and hold until "OEM" or "FAIL" displayed. If software revision displayed, all required buttons were not pressed properly or in time.

10 ADVANCED PARAMETERS MENU (CONTINUED)

FACTORY RESTORE

Factory Restore loads the default settings as shipped from GAC into the current settings and saves them for next power up. After restoration, unit must be repowered to start engine. Factory Restore can only be done during power up.

FACTORY RESTORE

Displays "FACT" when settings have been restored successfully into current user settings. Repower unit to start.

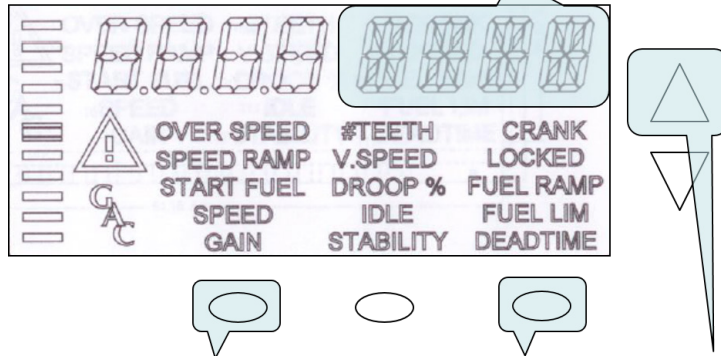

During Power Up, Press LEFT, RIGHT, and UP Buttons simultaneously and hold until "FACT" displayed. If software revision displayed, all required buttons were not pressed properly or in time.

11 FAULT CODES

ADVANCED MENU PARAMETERS (CONFIGURABLE)

CODE	CAUSE	EFFECT	CUSTOMER ACTION
1	Actuator over current (continuous)	Actuator turned off for 30 s.	Check actuator wiring.
2	Loss of speed signal (inc/dec in speed by more than 64 Hz in 4 ms, 16 K Hz/s)	WARNING indicator blinks then system shutdown	Check speed pickup.
3	Over speed (speed exceeds OVER SPEED setting for 12 ms)	WARNING and OVER SPEED indicators blink then system shutdown.	Check fuel system, OVER SPEED, SPÉED, and V.SPEED
203	Variable Speed settings are reversed. V.SPEED is lower than SPEED.	WARNING indicator blinks, speed set to V.SPEED setting, variable speed input unresponsive.	Flip V.SPEED and SPEED settings.
206	No potentiometer/signal detected on variable speed input when VSPD enabled.	WARNING indicator blinks, speed set to SPEED setting.	Check potentiometer wiring.
241	New software loaded. Configuration not compatible.	Default configuration used.	Reset configuration.
251	Software loaded on incompatible hardware.	WARNING indicator blinks then System shutdown.	Return unit to GAC
307	FLCU / NLCU Setting invalid	Load calculation done with 0.5 and 4.0 A values	Adjust NLCU / FLCU

IMPORTANT

For all other codes, note the condition and contact GAC. The WARNING indicator will blink and failures will cause a system shut down.

12 J1939 CAN INFO

J1939 Address: 26

PGN	DEFINITION	NOTES
61444	Engine Speed	Engine speed in RPM

13 SYSTEM TROUBLESHOOTING

SYSTEM INOPERATIVE

If the engine governing system does not function, the fault may be determined by performing the voltage tests described in Steps 1 through 3. Positive (+) and negative (-) refer to meter polarity. Should normal values be indicated during troubleshooting steps, then the fault may be with the actuator or the wiring to the actuator. Tests are performed with battery power on and the engine off, except where noted. See actuator publication for testing procedure on the actuator.

STEP	WIRES	NORMAL READING	PROBABLE CAUSE
1	F(+) & E(-)	Battery Supply Voltage (12 or 24 V DC)	<ol style="list-style-type: none"> DC battery power not connected. Check for blown fuse Low battery voltage Wiring error
2	C & D	1.0 V AC RMS min. While Cranking	<ol style="list-style-type: none"> Gap between speed sensor and gear teeth too great Improper or defective wiring to the speed sensor Resistance between D and C should be 130 to 1200 Ω. Defective speed sensor.
3	F(+) & A(-)	1.0 - 2.0 V DC While Cranking	<ol style="list-style-type: none"> SPEED or IDLE parameter set incorrectly CRANK or START FUEL set incorrectly Short/open in actuator wiring Defective speed control Defective actuator, see Actuator Troubleshooting

INSTABILITY

INSTABILITY	SYMPTOM	PROBABLE CAUSE
Fast Periodic	The engine seems to jitter with a 3Hz or faster irregularity of speed.	<ol style="list-style-type: none"> Readjust the GAIN and STABILITY for optimum control. In extreme cases, change the DEADTIME parameter.
Slow Periodic	Speed irregularity below 3Hz. (Sometimes severe)	<ol style="list-style-type: none"> Check fuel system linkage during engine operation for: <ol style="list-style-type: none"> binding high friction poor linkage DEADTIME Parameter set too high.
Non-Periodic	Erratic Engine Behavior	<ol style="list-style-type: none"> Increasing the GAIN should reduce the instability but not totally correct it. If this is the case, there is most likely a problem with the engine itself. Check for: <ol style="list-style-type: none"> engine mis-firings an erratic fuel system load changes on the generator set voltage regulator.

UNSATISFACTORY PERFORMANCE

SYMPTOM	NORMAL READING	PROBABLE CAUSE
Engine Over Speeds	<ol style="list-style-type: none"> Do Not Crank. Apply DC power to the governor system. 	<ol style="list-style-type: none"> If the actuator is at minimum fuel position and there exists an erroneous speed signal, then check speed sensor.
	<ol style="list-style-type: none"> Manually hold the engine at the desired running speed. Measure the DC voltage between Terminals A(-) & F(+) on the speed control unit. 	<ol style="list-style-type: none"> If the voltage reading is 1.0 to 2.0 V DC: <ol style="list-style-type: none"> SPEED parameter set above desired speed Defective speed control unit If voltage reading is > 2.0 V DC then check for: <ol style="list-style-type: none"> actuator binding linkage binding If the voltage reading is below 1.0 V DC check for defective speed control unit
	<ol style="list-style-type: none"> Check #TEETH parameter. 	<ol style="list-style-type: none"> Incorrect tooth count entered.
Over Speed shuts down engine after running speed is reached	<ol style="list-style-type: none"> Examine the SPEED and OVER SPEED operating parameters for the engine 	<ol style="list-style-type: none"> SPEED parameter set too high. OVER SPEED set too close to SPEED. Check SPEED RAMP parameter. Actuator or linkage binding. Speed Control unit defective. Gain too low.
Over Speed shuts down engine before running speed is reached	<ol style="list-style-type: none"> Check resistance between Terminals C&D. Should be 130 to 1200 Ω. See specific Magnetic Pick-up data for resistance. 	<ol style="list-style-type: none"> OVER SPEED set too low If the speed sensor signal is erroneous, then check the wiring.

13 SYSTEM TROUBLESHOOTING (CONTINUED)

UNSATISFACTORY PERFORMANCE

SYMPTOM	NORMAL READING	PROBABLE CAUSE
Actuator does not energize fully	1. Measure the voltage at the battery while cranking.	1. If the voltage is less than: a. 7 V for a 12 V DC system, or b. 14 V for a 24 V DC system, Then: 1. Check wiring 2. Check circuit protection/relay 3. Check charging system 4. Check battery
	2. Momentarily connect Terminals A and F. The actuator should move to the full fuel position.	1. Actuator or battery wiring in error 2. Actuator or linkage binding 3. Defective actuator 4. Fuse open. Check for short in actuator or harness. 5. Check START FUEL and CRANK
Engine remains below desired governed speed	1. Measure the actuator output, Terminals A & B, while running under governor control.	1. If voltage measurement is within 2 V DC of the battery supply voltage level, then fuel control is restricted from reaching full fuel position, possibly due to mechanical governor, carburetor spring, or linkage interference. 2. Check SPEED, IDLE, GAIN, START FUEL, and CRANK

DISPLAY ACCESS - LOCK / UNLOCK

To unlock the display, press and hold the UP and DOWN arrows simultaneously for 10 seconds.

To lock the display, press and hold the UP and DOWN arrows simultaneously for 2 seconds.



If unsuccessful in solving instability, contact GAC for assistance.
GAC@governors-america.com or call: 1-413-233-1888



EEG6500 Technical Assistance Worksheet

Please provide the following information so we assist you with timely, technical recommendations:

Date: _____

Company Name: _____

Contact Info: E-Mail Address: _____

Phone Number: _____

Reported Problem: _____

Engine Make, Model & Application: _____

Controller Model and Serial Number: _____

Actuator Model and Serial Number: _____

EEG6500 GOVERNOR SETTINGS		
Parameter	Factory Settings	Customer Settings
Gain	50 (Rated) 10 (Idle)	
Stability	50	
Deadtime	HI	
Speed	1500RPM	
Idle	900 RPM	
Fuel Limit %	100	
Start Fuel %	100	
Droop %	5.0	
Fuel Ramp %	10	
Speed Ramp	300 RPM/s	
V. Speed	1800 RPM (VSPD) 0 Hz (Trim)	
Overspeed	2000 RPM	
# of Teeth	120	
Crank	400 RPM	

ADVANCED SETTINGS		
Parameter	Factory Settings	Customer Settings
AUX	Off	
VSPD	Off	
LFG	Off	
LEAD	Off	
NLCU	0.5	
FLCU	4.0	
JADR	0	
FLTL	-----	
DATL	-----	
FLTL	-----	

ADVANCED MENU PARAMETERS (READ ONLY)		
Parameter	Factory Settings	Software Revision Number
SREV	-----	

ELECTRICAL CHECKS		
F(+) & E (-)	12 or 24 V DC	
C & D	1.0 V AC RMS Min. at Cranking	
F (+) & A (-)	1.0 to 2.0 V DC While Cranking	