

1 INTRODUCTION

GAC's Enhance Electronic Governor EEG7000 digital speed controller is designed to regulate engine speed on diesel and gaseous fueled engines. When paired with a GAC actuator the EEG7000 is a suitable upgrade for any mechanical governor system that needs flexibility, precision, and accurate control of governed speed.

The EEG7000 is designed for industrial engine applications including generator sets, mechanical drives, pumps, compressors and off-road mobile equipment. The GAC EEG7000 Interface Tool adds the ability to set parameters values and troubleshoot from your PC. With CAN J1939 capability it has the ability to accept TSC1 messages over USB as a mini engine control module (ECM). It can be controlled directly over J1939 with aftermarket displays such as ComAp, Dynagen, and Murphy – a solution for every application.

- ◆ Mini-ECU, J1939 TSC1 Control capable with Diagnostic Messages (DM)
- ◆ Isochronous, variable, or customizable droop governing
- ◆ 3 fixed speeds or variable speeds with Direct 0 – 5 V DC, 5 kΩ, or 4 – 20 mA Input
- ◆ Built-in USB port for easy configuration with free software
- ◆ Black smoke reduction, speed ramp control, load sharing/synchronizing option, Cummins EFC-capable
- ◆ Built-in speed switch output for crank or overspeed
- ◆ Battery voltage, engine hour meter and service timer
- ◆ Fully sealed, IP67
- ◆ Multi - V DC
- ◆ Gaseous or Diesel
- ◆ Built-In Configurable Speed Switch Output



2 EEG7000 SPECIFICATIONS

PERFORMANCE		ENVIRONMENTAL	
Isochronous Operation	± 0.25 %	Ambient Temperature	-40 to 85 °C [-40 to 180 °F]
Speed Range	100 - 12 kHz	Relative Humidity	up to 90 % non-condensing at 38 °C
Droop Range	0.1 - 25 % regulation	Vibration	4 g, 20 - 1000 Hz
Speed Ramp Time		Shock	Per J1455
Acceleration. Adj. Range	25 to 2000 RPM/s	Testing	100 % Functional Testing
Deceleration. Adj. Range	25 to 2000 RPM/s	All Surface Finishes	Fungus Proof, Corrosion Resistant
Starting Fuel Adjustment		ELECTRICAL	
Actuator Ramp Rate	1 to 100 %	Power Supply	12 - 24 V DC Battery Systems
Actuator Begin Point	0 to 100 %	Continuous Supply Voltage	6.5 to 32 V DC
Overspeed Set Point	400 to 6000 RPM	Polarity	Negative Ground (Case Isolated)
Crank Termination Set Point	100 to 1000 RPM	Power Consumption	100 mA (No Actuator Current)
Speed Switch Adjustment Range	1000 - 100000 Hz	Actuator Current	6 A Continuous, 8 A Peak
Speed 1	0 to 6000 RPM	COMPLIANCE / STANDARDS	
Speed 2 & 3	150 to 6000 RPM	Agency	CE and RoHS Requirements
Reverse Power Protection	Yes	Communications	USB, RS-232-C, SAE J1939
Transient Voltage Protection	60 V DC	PHYSICAL	
Load Share / Synchronization Input	0 - 10 V DC (5 V Nominal, Selectable Polarity, 145 Hz / V Sensitivity)	Dimension	See Section 3, Installation
Speed Sensor Signal Input	1.0 - 60.0 V RMS	Weight	8 ozf [227 gf]
Speed Switch (SSW)	Rated to 2 A DC	Mounting	Any position, Vertical preferred

3 EEG7000 INSTALLATION

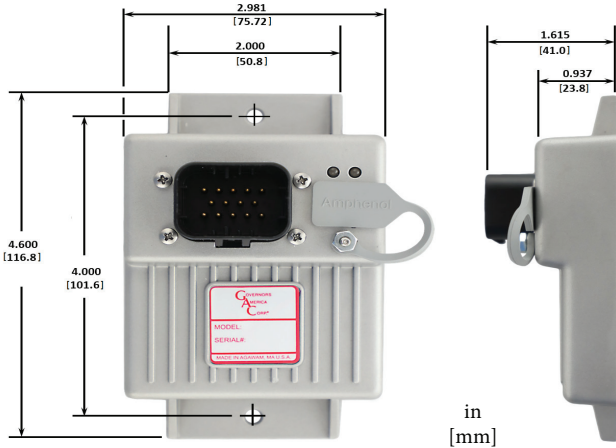

Before you begin, note the following required items:

- ◆ A Windows 7 or better computer with USB port and Internet connection
- ◆ 14-pin connector (GAC EC1502) or cable harness assembly (CH1520)



Vertical orientation allows for the draining of fluids in moist environments.



Mount in a cabinet, engine enclosure, or sealed metal box.



Avoid extreme heat. Do not mount next to turbo-charger, exhaust manifold, or other high temperature equipment.



An overspeed shutdown device, independent of the governor system, should be used to prevent loss of engine control which may cause personal injury or equipment damage.

Do not rely exclusively on the governor system electric actuator to prevent overspeed. A secondary shutoff device, such as a fuel solenoid must be used.



4 LED DEFINITIONS

Error messages display in the EEG7000 Interface Tool and on the controller as LED displays.

LED	COLOR	DEFINITION
1	SOLID GREEN	Controller is powered on
2	OFF	No faults, system is working properly
2	SOLID YELLOW	Warning: Engine service due, or other warning as displayed in the GAC software. If using J1939 see the J1939 CAN INFO / DIAGNOSTIC TROUBLE-SHOOTING CODES (DTC) section in this guide.
2	BLINKING RED	Actuator current high, shutdown and retry in 30 s.
2	SOLID RED	System shut-down: <ul style="list-style-type: none"> • Actuator current exceeds 8.0 A for 12 ms continuously • Engine speed drops or rises faster than 25 kHz/s • Engine speed exceeds overspeed • User commanded engine shutdown • Incompatible hardware • Loss of magnetic pickup signal

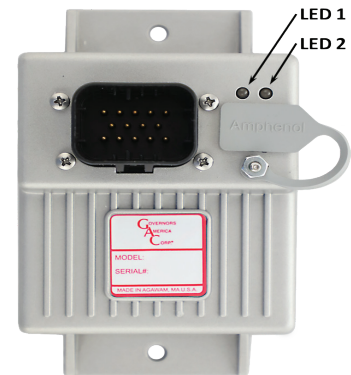

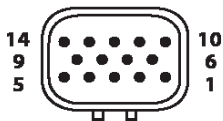
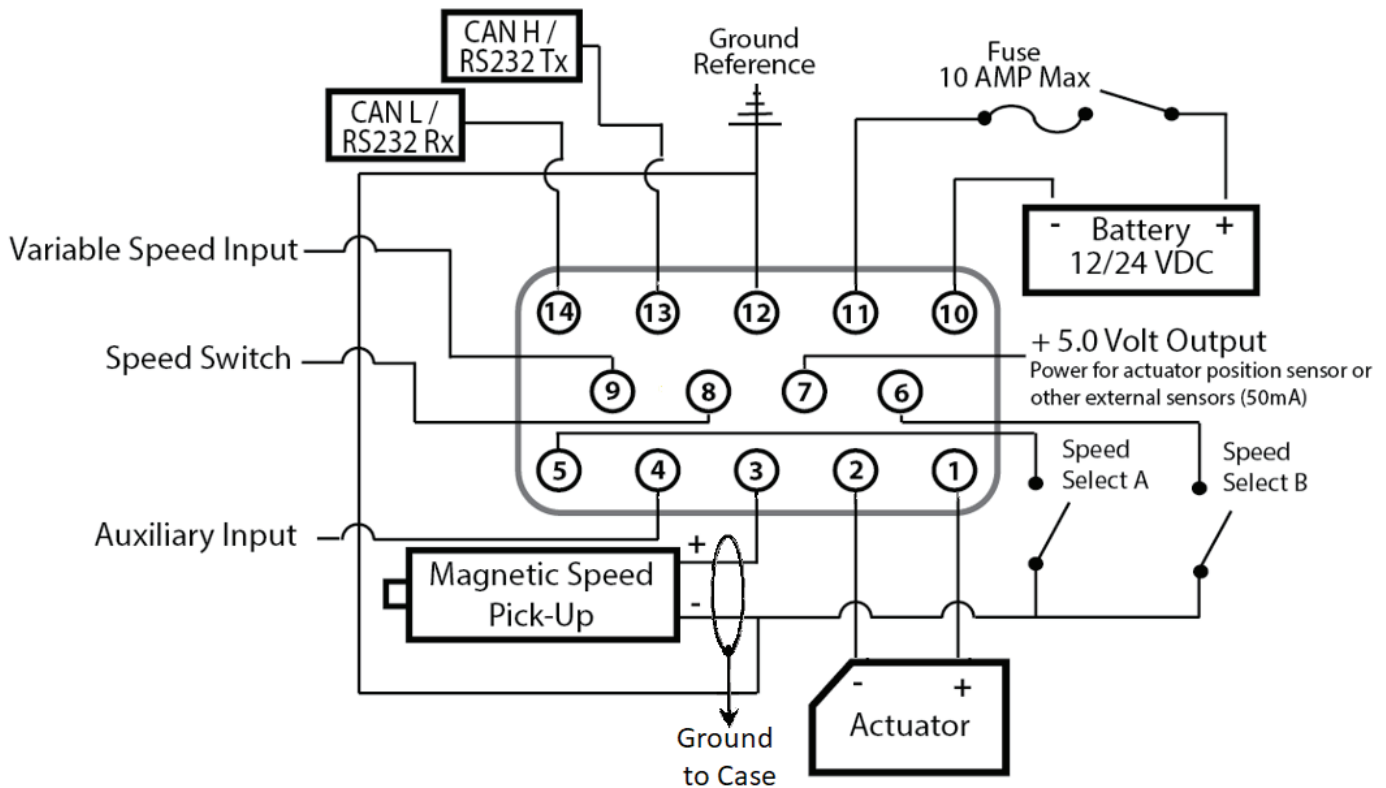

14-pin AMPSEAL requires GAC mating connector kit EC1502 or cable harness CH1520. Use a crimping tool to connect the connector and harness.

PIN	DEFINITION	GAUGE	NOTES
1	Actuator (+)	16	Polarity not required for actuator
2	Actuator (-)	16	
3	Magnetic Pickup (+)	20	* Ground to Pin 12
4	Aux Input	20	* 0 - 10 V Range, 5 V Nominal, Selectable Polarity
5	Speed Select A	20	* Ground to Pin 12 to Enable
6	Speed Select B	20	* Ground to Pin 12 to Enable
7	+5.0 Volt Output	20	* Power for external sensors (50 mA)
8	Speed Switch Output	16	* 2A MAX, LSO
9	Variable Speed Input	20	* Potentiometer, 0-5 V DC or 4-20 mA, selectable polarity
10	Battery Ground (-)	16	Battery ground
11	Battery Power (+)	16	A 10 amp fuse must be installed in the positive battery lead to protect against any overload or short circuit or reverse voltage
12	Ground Reference / Speed Select Ground	20	Ground reference for magnetic pick-up (-), sensors and switches
13	CAN H / RS232 Tx	20	CAN bus or RS-232 connections
14	CAN L / RS232 Rx	20	

WIRING RECOMMENDATIONS

- ◆ Use the GAC mating connector EC1502 or cable harness CH1520 with the 14-pin AMPSEAL with the EEG7000.
- ◆ Ground the EEG controller case to the engine battery (-).
- ◆ Wires must be twisted and/or shielded for their entire length (14 turns per foot). Ground shield to case.
- ◆ Minimum gap between speed sensor and gear teeth is 0.02 in [.5 mm].
- ◆ The minimum speed sensor voltage is 1 V AC RMS during crank.
- ◆ See the product bulletins of the equipment you are connecting to for more detailed wiring information on those items.
- ◆ Values are assigned to parameters using the EEG7000 Interface Tool.

*Pin assignments are not the same as EDG6000. Review all diagrams and/or additional notes before wiring.

PIN 3 - MAGNETIC SPEED PICK-UP

A magnetic speed sensor detects when ring gear teeth pass the tip of the magnetic speed sensor. The output signal is an AC sine wave whose frequency is converted to crankshaft revolutions per minute (RPM). The following are required:

- A magnetic pickup must be installed in the engine bell housing, ring gear case, or fabricated bracket.
- All wires must be twisted and/or shielded for their entire length (14 turns per foot).
- Ground shield to case. Do not tie case to ground.
- The magnetic speed sensor voltage should be at least 1 V RMS while cranking. During operation, 5 to 10 V RMS is recommended.
- If the EEG7000 detects no input from the magnetic pickup, the EEG sets the actuator to 0 V DC and the speed to 0 RPM. If the EEG detects loss of magnetic pickup, LED 2 turns solid red and the system must be reset. To reset the EEG, cycle DC power.
- The magnetic speed sensor connections **MUST BE TWISTED AND/OR SHIELDED** for their entire length.
- The speed sensor cable shield must only be connected to the case. The shield should be insulated to ensure that no other part of it comes into contact with engine ground, otherwise stray signals may be introduced into the speed switch.
- Minimum gap between speed sensor and gear teeth is 0.02 in [0.5 mm]. When the engine is stopped, adjust the gap between the magnetic speed sensor and the ring gear teeth. Usually, backing out the speed sensor 3/4 turn after touching the ring gear tooth will result in a satisfactory gap.

PIN 4 - AUXILIARY INPUT

The auxiliary (AUX) terminal accepts input signals from load sharing units, auto synchronizers, and other governor system accessories.

The AUXILIARY input from Pin 4 is activated by selecting ON at the auxiliary input in the Interface Tool Main menu.

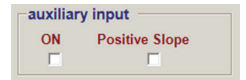

The AUX function decreases engine speed with increasing input voltage, the polarity shift function increases engine speed with increasing input voltage. Aux input is nominally 5.0 V +/- 5.0 V DC.

The Aux terminal accepts signals from:

- GAC accessories
- Auto synchronizers
- Load sharing units
- Other governing accessories

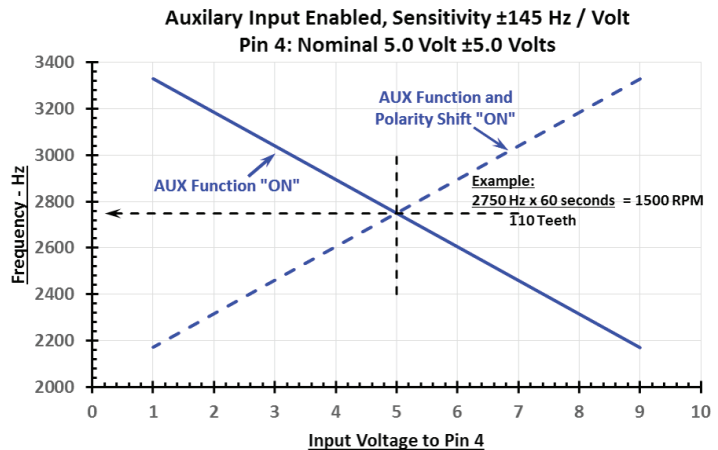
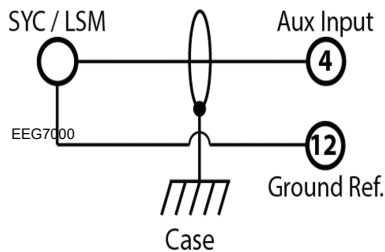

6 EEG7000 BASIC WIRING (CONTINUED)

PINS 5 AND 6 - SPEED SELECT

The EEG7000 has two inputs which, in various combinations, allow the user to use three fixed speed settings or the variable speed setting. This is accomplished by tying inputs to ground or leaving them open. Fixed Speed 1 can be set to idle as required.

WIRING COMBINATIONS		
PIN 5	PIN 6	Speed Mode
Open	Open	Variable Speed (or Fixed Speed)
Ground	Ground	Fixed Speed 1
Open	Ground	Fixed Speed 2
Ground	Open	Fixed Speed 3

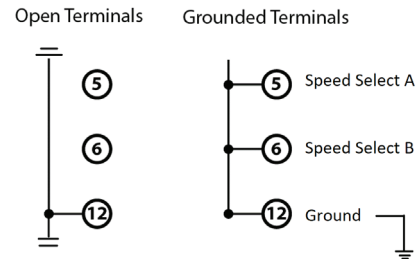

Speed is set from the Interface Tool FIXED SPEEDS and VARIABLE SPEED 4 blocks.

- ◆ To set variable speed, select the analog mode for your variable input signal, and input desired RPM.
- ◆ See Section 11, [Setting Variable Speed Parameters](#) for more details and details on using input range and INPUT CALIBRATION.

FIXED SPEEDS			
	Speed	Gain	Droop
Fixed Speed 1	1500	50	0
Fixed Speed 2	1500	50	0
Fixed Speed 3	1500	50	0
	RPM	%	%

VARIABLE SPEED 4

	Speed	Gain	Droop
Min. Speed	1500	50	0
Max. Speed	1500	50	%
	RPM	%	%

input range

Press Button To Calibrate
Min/Max Input Values

Minimum Input	0.0	%
Maximum Input	100.0	%

INPUT CALIBRATION

Measured Input	0.0	%
Measured Voltage	0.000	V

PIN 7 - ANALOG INPUT

Pin 7 provides analog input from external trim or variable speed potentiometers. Use Pins 7 to create resistive input: Select 0 - 5 V / Resistive and connect a 5 k Ω potentiometer between Pins 7, 9 and 12 (also see Pin 9 - Variable Speed).

PIN 8 - SPEED SWITCH OUTPUT (SSW)

When the EEG7000 detects engine speed has reached the user defined Limit / Threshold value, the EEG7000 controller changes the state of Pin 8. The SSW can be used for overspeed protection, starter cutoff (crank termination), and other general auxiliary functions.

- ◆ The SSW adjustment range is 100 to 6000 RPM. The default value is 1800 RPM and the default state (Mode) is NORMALLY OPEN.
- ◆ When NORMALLY OPEN is selected the SSW output on Pin 8 will energize at the set speed. When NORMALLY CLOSED is selected output from Pin 8 will de-energize at the speed setting.
- ◆ When the LATCHING box is checked the SSW output state is fixed until power to the unit is cycled. When the box is not checked the output state automatically resets at 0 RPM. The default is checked (ON).

6 EEG7000 BASIC WIRING (CONTINUED)

PIN 9 - VARIABLE SPEED

Variable speed is enabled when Pins 5 and 6 are **not** grounded. Connect a 5 kΩ potentiometer, 0 - 5 V DC or 4 - 20 mA speed input signal, to Pin 9. The default setting is 0 - 5 V DC with variable speed available.

The variable speed in the Interface Tool must be set to 0 - 5 V DC or 4 - 20 mA to use this function.

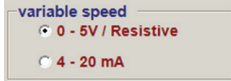

Setting variable speed requires a potentiometer, available from GAC. A potentiometer calibration within the Interface Tool characterizes the selected potentiometer.

Variable Speed can be used as another fixed speed setting if both Min. Speed and Max. Speed values are set to the same RPM and no potentiometer is connected.

For more details on setting variable speed see Section 11, [Main Menu Parameters](#).

5K Potentiometer

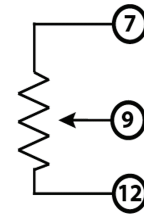

NOTE Setting the Min Speed and Max Speed to the same value with no input on Pin 9 enables you to use Variable Speed as an additional fixed speed setting.

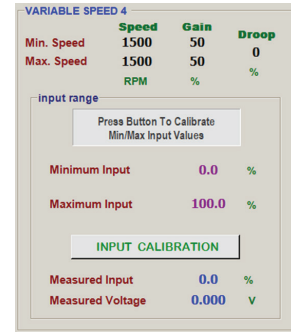

PINS 13 AND 14 - CAN H AND CAN L - RS-232

The CAN output supports J1939 protocol for basic engine speed and Diagnostic Trouble Codes (DTCs). More on the diagnostic trouble codes (DTCs) detailed in Section 13, [J1939 CAN INFORMATION](#) in this bulletin.

- ◆ The CAN bus must be terminated at each end by a 120 Ω resistor to create 60 Ω across.
- ◆ Use cable harness CH1520, 7 AWG, or EC1502 mating connector kit with twisted pair at each end that meets SAE J1939 or SAE J1128 standards.
- ◆ Harness should be no longer than 40 m (130 ft).

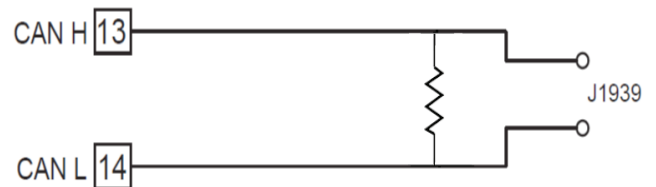

7 CONNECTING EEG7000 TO THE INTERFACE TOOL

The EEG7000 can be set up using GAC's EEG7000 Interface Tool. The installation file is found on the GAC website WWW.GOVERNORS-AMERICA.com in the Software Downloads section. Once the tool is installed on your PC and power applied to the EEG7000, the Interface Tool allows you to connect the EEG7000 to the Interface Tool.

1. After installation, with power applied to the EEG7000 and the EEG is connected to the PC, double-click the EEG7000 Interface Tool icon on your PC desktop.
2. The Communications menu displays. Select the USB Comm port connected to the EEG7000 from the drop down menu.
3. Click Connect.
4. When connection is complete, the Main menu displays.

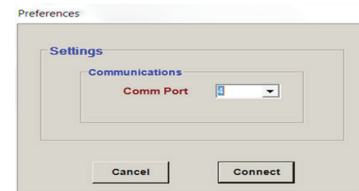

8 PRE-START

The following parameter values must be set before starting the engine. Values in black text are saved automatically as they are changed. Blue text displays current read-only values and cannot be changed.

MAIN MENU

The screenshot shows the EEG7000 Interface Tool with the following parameter values:

Section	Parameter	Value	Unit
STARTING PARAMETERS	Crank Termination	400	RPM
	Actuator Ramp Rate	10	% / s
	Actuator Begin Point	100	%
SETUP & SAFETY	Overspeed	1800	RPM
	Flywheel Teeth	120	
	Speed Ramp Up	300	RPM / s
	Speed Ramp Down	300	RPM / s
ENGINE RESPONSE	Active Speed Mode	4	
	Active Gain	50	%
	Duty Cycle Limit	100	%
	Stability	50	%
ENGINE DATA	Actual Speed	0	RPM
	Magnetic Pickup Frequency	0	Hz
	Governor Commanded Speed	400	RPM
	Operator Requested Speed	1500	RPM
TIMERS	Non-Resettable	0.0	Hours
	Resettable	0.0	Hours

SETUP & SAFETY

- At the Main menu SETUP & SAFETY, note if the Flywheel Teeth value is correct for your engine. If not, double click on the value and change it.
- Enter values for all the SETUP & SAFETY parameters:
 - Overspeed
 - Flywheel Teeth
 - Speed Ramp Up
 - Speed Ramp Down

Parameter	Value	Unit
Overspeed	1800	RPM
Flywheel Teeth	120	
Speed Ramp Up	300	RPM / s
Speed Ramp Down	300	RPM / s

STARTING PARAMETERS

- Enter values for all the STARTING PARAMETERS:
 - Crank Termination
 - Actuator Ramp Rate
 - Actuator Begin Point

Parameter	Value	Unit
Crank Termination	400	RPM
Actuator Ramp Rate	10	% / s
Actuator Begin Point	100	%

NOTE More details on these parameters are available in Section 11, [Main Menu Parameters](#)

9 STARTING THE ENGINE



Do not rely exclusively on the governor system electronic actuator to prevent overspeed. A secondary shutoff device, such as a fuel solenoid must be used. STOP ENGINE shuts down the actuator, not the engine.



Crank the engine with DC power applied to the governor system. The initial amount of power to the actuator is determined by the ACTUATOR BEGIN POINT parameter (default is 100% open). ACTUATOR RAMP RATE will control the rate at which fuel is increased to start the engine (default is 10%).

10 ADJUSTING FOR STABILITY

Once the engine is running at operating speed and at no load, the following governor performance adjustment can be made to increase engine stability.

Parameter	Adjustment Procedure
P (GAIN)	<ol style="list-style-type: none"> Increase the value until instability develops. Gradually decrease the value until stability returns. Decrease the value one increment further to ensure stable performance. <p>If instability persists, decrease the stability value.</p>
I (STABILITY)	<p>Follow the same adjustment procedure as the Gain parameter.</p> <p>If instability persists, adjust the deadtime parameter.</p>
D (DEAD TIME)	Select either HI or LO (Default is HI)

NOTE P, I, & D parameter adjustments may require minor changes after engine load is applied. Normally, adjustments made at no load achieve satisfactory performance. If further performance improvements are required, see Section 14, **SYSTEM TROUBLESHOOTING**.

11 MAIN MENU PARAMETERS

The EEG7000 Interface Tool consists of a Main menu that displays all the parameters and options available on the Interface tool in one screen.

From the Main menu you can also select File, Configure, and Options menus.

The Main menu screen shown here shows factory default settings.

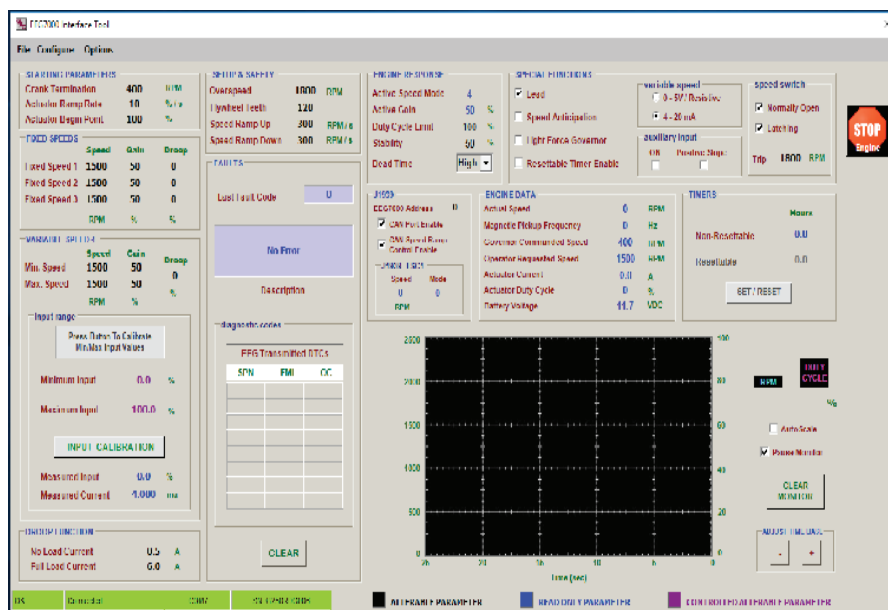

CONFIGURE MENU

Configure	Options
Unit Information	Ctrl+U
Setup Connection...	Ctrl+N

Unit Information	Details the EEG7000 speed control unit including serial number.
Setup Configuration	Sets up access to USB ports.

OPTIONS MENU

Options	
Device Monitor	Ctrl+D
Disable Tool Tips	Ctrl+T
Restore Factory Defaults	Ctrl+R
About...	

Device Monitor	Opens the device monitor in an additional window.
Tool Tips	Enables/disables the ability to display a parameter definition while hovering cursor.
Restore Factory Defaults	Resets all settings to factory default settings. Factory settings are shown in the above main menu.
About	Displays information about the Interface Tool

11 MAIN MENU PARAMETERS (CONTINUED)

STARTING PARAMETERS

STARTING PARAMETERS

Parameter	Range	Default	Definition
Crank Termination	100 - 1000	400	RPM at which EEG switches from starting to governing
Actuator Ramp Rate	1 - 100	10	Throttle position's rate of change from the throttle begin point to 100%, during the start/crank cycle (% / s)
Actuator Begin Point	0 -100	100	Starting position of the actuator during the start/crank cycle (%)

STARTING PARAMETERS		
Crank Termination	400	RPM
Actuator Ramp Rate	10	% / s
Actuator Begin Point	100	%

SETUP & SAFETY

SETUP & SAFETY

Parameter	Range	Default	Definition
Overspeed	400 - 6000	1800	RPM to automatically shut off the actuator / shut down the engine.
Flywheel Teeth	60 - 250	120	Number of teeth on flywheel
Speed Ramp Up	25 - 2000	300	Rate of acceleration controlled by the speed controller when a command to increase RPM is received.
Speed Ramp Down	25 - 2000	300	Rate of deceleration controlled by the speed controller when a command to decrease RPM is received.

SETUP & SAFETY		
Overspeed	1800	RPM
Flywheel Teeth	120	
Speed Ramp Up	300	RPM / s
Speed Ramp Down	300	RPM / s

Conversion Formulas:

$$\text{Hertz}_{\text{MAG PICKUP}} = \frac{(\text{RPM} \times \# \text{ Teeth})}{60\text{sec}}$$

$$\text{RPM} = \frac{(\text{Hertz}_{\text{MAG PICKUP}} \times 60\text{sec})}{\# \text{ Teeth}}$$

FIXED SPEED

FIXED SPEED PARAMETERS

Parameter	Range	Default	Definition
Speed 1	0 - 6000	1500	Selects one of three fixed speeds. (RPM)
Speed 2 & 3	150 - 6000	1500	
GAIN 1,2, & 3	1 - 100	50	Separate GAIN adjustment for each fixed speed.
Droop 1, 2, & 3	0 - 25	0	Separate DROOP adjustment for each fixed speed.

FIXED SPEEDS			
	Speed	Gain	Droop
Fixed Speed 1	1500	50	0
Fixed Speed 2	1500	50	0
Fixed Speed 3	1500	50	0
	RPM	%	%

Idle is set with Speed 1 of the speed control settings on the Engine Tuning menu.

An additional fixed speed setting can be created using the variable speed setting, when Min Speed and Max Speed are set to the same value.

DROOP PARAMETERS

Droop minutely decreases frequency as load is increased, balancing power fluctuations. Interface Tool droop settings require both load and no load values as well as the percentage of droop you want used.

DROOP FUNCTION PARAMETERS

Parameter	Value / Range	Default
No Load Current	0.0 - 5.5 A	0.5
Full Load Current	0.5 - 6.0 A	6.0

11 MAIN MENU PARAMETERS (CONTINUED)

ADJUSTING FOR DROOP

After the initial set up is completed and the Flywheel Teeth, Crank Termination Speed and Fixed Speed inputs are set, go to the DROOP FUNCTION parameters in the lower left hand corner of the Interface Tool.

1. Confirm that the **LEAD** circuit is off. Default position is ON.
2. Set the **NLCU** (No Load Current) to the measured / displayed current value when operating at no load rated speed (default value is 0.5 amps.)
3. Set the **FLCU** (Full Load Current) to the measured / displayed current value when operating at full load rated speed (default value is 6.0 amps.)
4. Select and set DROOP to the desired percentage for each of the three fixed speeds.

DROOP FUNCTION		
No Load Current	0.5	A
Full Load Current	4.0	A

FIXED SPEEDS			
	Speed	Gain	Droop
Fixed Speed 1	1500	50	0
Fixed Speed 2	1500	50	0
Fixed Speed 3	1500	50	0
	RPM	%	%

The NLCU entered must be less than the FLCU and the difference between the two must be at least 0.5 A. If an invalid combination is entered a warning will be flagged and the values default to 0.5 A and 6.0 A.

VARIABLE SPEED PARAMETERS

- Both Min Speed and Max Speed settings have a range of 150 to 6000 RPM, the default value is 1500 RPM for both.
- When Min Speed and Max Speed parameters are set to the same value, with no input on Pin 9, Variable Speed 4 is used as an additional fixed speed setting.
- If Min Speed setting is higher than the Max Speed, increasing the speed input signal / potentiometer position will decrease RPM.

VARIABLE SPEED PARAMETERS

Parameter	Range	Default	Definition
Min Speed	150 - 6000	1500	Desired RPM with minimum variable speed input signal
Max Speed	150 - 6000	1500	Desired RPM with maximum variable speed input signal.

VARIABLE SPEED 4			
	Speed	Gain	Droop
Min. Speed	1500	50	0
Max. Speed	1500	50	%
	RPM	%	%



Perform the following procedure with the speed controller powered on but the engine not running to set the variable speed limits.

VARIABLE SPEED SETUP PROCEDURE

1. Variable Speed, Mode 4, is selected when pins 5 and 6 are open, as described in Section 4 , [Wiring](#). It is the default Mode when your unit is first powered on.
2. Select the correct variable speed input signal, either 0 - 5V / Resistive or 4 - 20 mA.
3. From VARIABLE SPEED 4 click INPUT CALIBRATION. The setting sequence will step through each parameter, click Continue after each step.
4. Set Droop with the range: 0.0 to 25%
5. Set Min Speed value with input signal at either 0 volts, 4 mA or with the potentiometer in the full counterclockwise position.
 - Min Speed Gain
 - Min RPM
 - Min Position %
6. Set Max Speed value with input signal at either 5 volts, 20 mA or with the potentiometer in the full clockwise position.
 - Max Speed Gain
 - Max RPM
 - Max Position
7. A new window displays, confirming the calibration is complete.

variable speed	
<input checked="" type="radio"/>	0 - 5V / Resistive
<input type="radio"/>	4 - 20 mA

VARIABLE SPEED 4			
	Speed	Gain	Droop
Min. Speed	1500	50	0
Max. Speed	1500	50	%
	RPM	%	%
input range			
Press Button To Calibrate Min/Max Input Values			
Minimum Input	0.0	%	
Maximum Input	100.0	%	
INPUT CALIBRATION			
Measured Input	0.0	%	
Measured Voltage	0.000	v	

11 MAIN MENU PARAMETERS (CONTINUED)

VARIABLE SPEED PARAMETERS

- **Voltage Input:** (Select 0 - 5 V / Resistive) Voltage to 5.0 V, above 5.0 V DC the variable speed function will be clamped at 100%, RPM response to voltage is linear.
- **Resistive Input:** (Select 0 - 5 V / Resistive) Connect a 5 k Ω potentiometer between Pins 7, 9 and 12 as shown under Variable Speed on page 2. Maximum operating voltage is 5.0 V DC, response to this input is linear.
- **Current Input:** (Select 4 - 20 mA) The Min Speed parameter sets the low speed at 4 mA, the Max Speed parameter sets the high speed at 20 mA. If the input current drops below 4mA, variable speed will be clamped at 0 %. If the input current level exceeds 20 mA, variable speed will be clamped at 100 %. RPM response to current is linear.

0 - 5 V DC Input To Pin 9

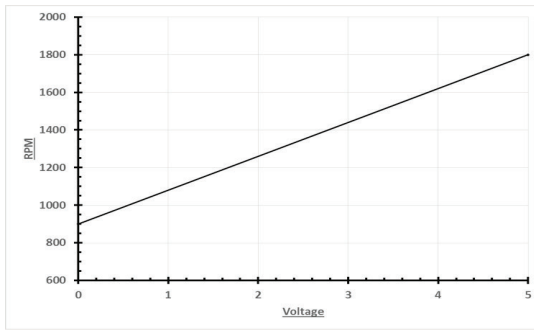

4 - 20 mA Input To Pin 9

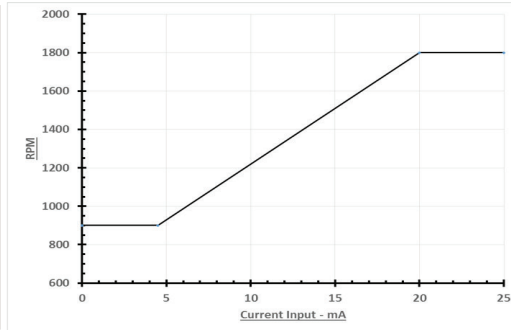

SPECIAL FUNCTIONS

The EEG7000 offers a number of GAC specific capabilities as well as helpful tools.

SPECIAL FUNCTIONS PARAMETERS

Parameter	Description	Value / Range	Default
Auxiliary input ON	Enables connections to synchronizing and load sharing equipment. This allows speed adjustments through the auxiliary input voltage, accepting a 1-9 V DC signal, biased at 5 V, and selectable response polarity. In response the EEG can increase or decrease voltage but does not change engine speed.	On / Off	Off
Auxiliary input Positive Slope	Controls auxiliary / load sharing function	On / Off	Off
Speed switch Normally Open	NORMALLY OPEN energizes the speed switch output on Pin 8 at the set speed . When the box is not checked (NORMALLY CLOSED) output from Pin 8 will de-energize at the set speed.	On / Off	On
Speed switch Latching	When Latching is on the speed switch output state is fixed until power to the unit is cycled. When the box is not checked the output state automatically resets at 0 RPM.	On / Off	On
Speed switch Trip	The set speed RPM.	0 - 6000 RPM	1800
Lead	Improves speed controller responsiveness, typically increasing range of gain adjustment. This function allows for more active control to increase the performance in typically slow engines.	On / Off	On
Speed Anticipation	Speed anticipation ON reduces RPM recovery time during high load transients and requires both no load (NLCU) and full load current (FLCU) values are entered.	On / Off	Off
Light Force Governor	Provides finer adjustment resolution for smaller actuators. It is designed to work with low current small actuators, like T1 ATB, ALR/ALN, 100/103/104 series and normally closed Cummins EFC actuators. Select the Light Force Governing block in the PID Tuning block when using small actuators to improve adjustments as they respond very quickly to input changes over a smaller range of operating current, using a fraction of the PID and current output of a normal actuator.	On / Off	Off
Resettable Timer Enable	Service timer used, yes or no.	On / Off	Off

ENGINE RESPONSE

ENGINE RESPONSE PARAMETERS

Parameter	Range	Default	Definition
Active Speed Mode	1 - 4		The objective fixed or variable speed number 1, 2, 3, or 4 for PID governor response optimization
Active Gain	1 -100, 100 = Max Gain	50	GAIN is the Proportional (P) set point of the PID control
Duty Cycle Limit	0 - 100%	100%	Maximum allowable throttle % the system can command
Stability	1 -100, 100 = Longest Time	50	STABILITY is the Integral (I) set point of the PID control
Dead Time	LO (0) - HI (1)	HI (1)	DEADTIME is the Derivative (D) set point of the PID control

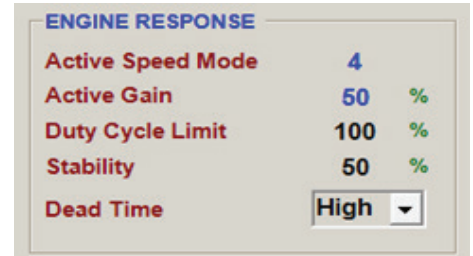

Each speed setting has a separate GAIN setting. The speed selection number and active GAIN are shown on Engine Response.

ENGINE DATA

Engine data displays current actual values, this is for review only. .

ENGINE DATA

Parameter	Units
Actual Speed	RPM
Mag Pick-Up Frequency	Hertz
Governor Commanded Speed	RPM
Operator Requested Speed	RPM
Actuator Current	Amps
Actuator Duty Cycle	Percent
Battery Voltage	VDC

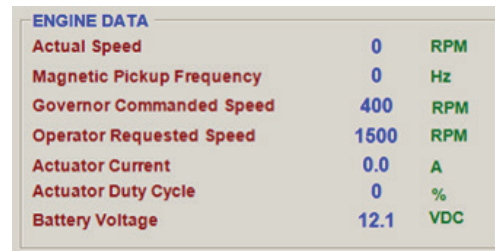

UNIT INFORMATION

Unit Information describing the Date the unit was programmed, its Software Version, Hardware Revision level, Device and Build ID numbers can be accessed through the Configure drop down menu. Click on Unit Information and a new screen displays with these the following Read-Only parameters.

UNIT INFORMATION		
Parameter	Value / Range	Default
Save Data	Read-Only	N/A
Software Ver.	Read-Only	N/A
Hardware Rev.	Read-Only	N/A
Device ID	Read-Only	N/A
Build ID	Read-Only	N/A

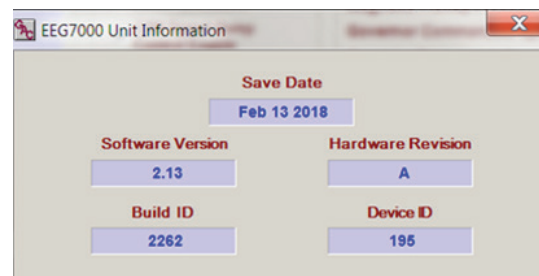

12

DEVICE MONITOR

A Device Monitor screen is part of the EEG7000 Interface Tool. It optimizes the individual view showing RPM and actuator duty cycle versus time. It has the option of adjusting the Time Base of the 'X' axis and selecting standard or Auto Scaled 'Y' axis.

- Device Monitor can be opened in a separate screen from the Options menu.
- Adjust the timing scale for displayed information with the ADJUST TIME BASE + and - buttons.
- Auto Scale and Pause monitor selections are also options.
- Duty Cycle and current RPM are also displayed.

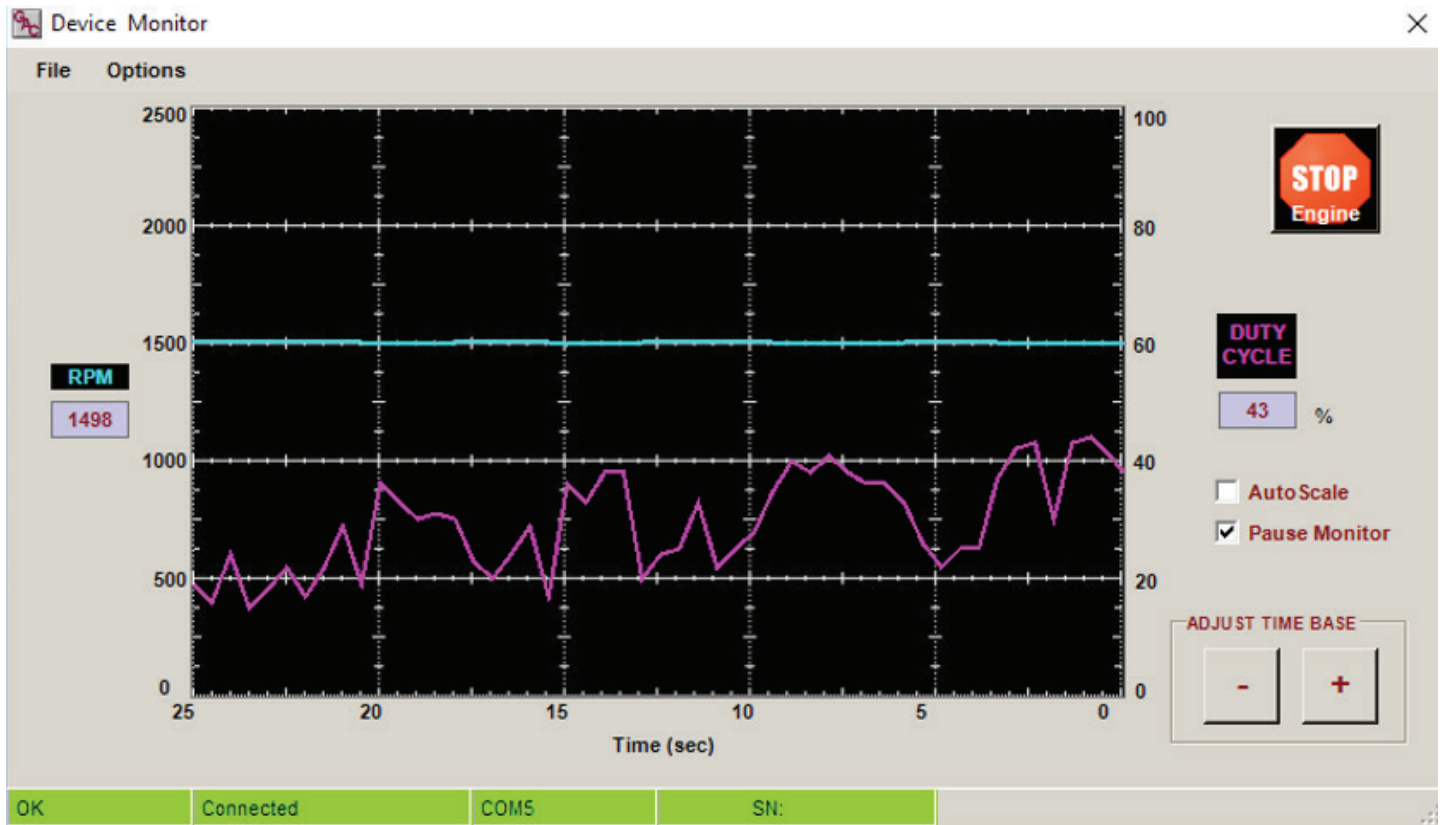

CAN JS1939 bus device communication is supported to receive and display JS1939 messages.

J1939 PARAMETERS		
Parameter	Value / Range	Default
J1939 Address	0 - 253	0
CAN Port Enable	On / Off	On
CAN Speed Ramp Control Enable	On / Off	On

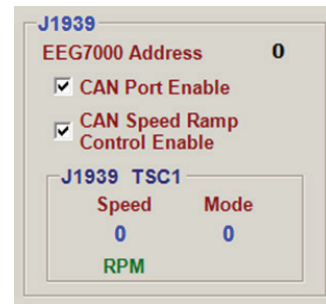

Use the EEG7000 Interface Tool to set the J1939 parameters.

1. At the J1939 menu select CAN Port Enable for the Communication mode.
2. Select the CAN Speed Ramp Control Enable
3. Use the Clear button on the Faults area to clear current faults.

SYSTEM FAULTS / J1939 DTC'S					
FAULT CODE	CONDITION	J1939 SPN	J1939 FMI	J1939 LAMP / LED DISPLAY	ACTION
1	Actuator Overcurrent	638 (Actuator)	Current High (6)	Protect / Blinking Red	Shutdown, retry 30 seconds
2	Loss of Speed Sensor	636 (Speed Sensor)	Abnormal Signal (8)	Stop / Shutdown	Shutdown
3	Overspeed	190 (Engine Speed)	Data Above Range (0)	Stop / Shutdown	Shutdown
4	User Shutdown	1110 (Eng. Shutdown)	Data Incorrect (2)	Stop / Shutdown	Shutdown
241	EEPROM Read	628 (CPU / Memory)	Out of Calibration (13)	Warning / Solid Yellow	None
285	TSC1 Unsupported Mode	695 (Override mode)	Data Incorrect (2)	Warning / Solid Yellow	Revert to selected speed
286	TSC1 Message Rate Error	3349 (Message Rate)	Data Incorrect (2)	Warning / Solid Yellow	Revert to selected speed
287	TSC1 Message Count Error	4206 (Message Counter)	Data Incorrect (2)	Warning / Solid Yellow	Revert to selected speed
288	TSC1 Speed Request Invalid	898 (Requested Speed)	Data Incorrect (2)	Warning / Solid Yellow	Revert to selected speed
289	TSC1 Invalid Checksum	4207 (Checksum)	Data Incorrect (2)	Warning / Solid Yellow	Revert to selected speed
290	TSC1 Destination Address	1483 (Source Address)	Data Incorrect (2)	Warning / Solid Yellow	Revert to selected speed
305	Service Due	916 (Service Delay)	Data Incorrect (2)	Protect / Solid Yellow	None

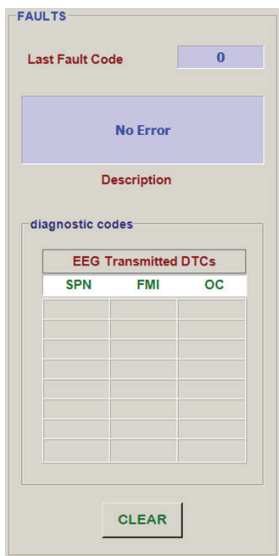

In the unlikely event of a GAC product causing a fault, the numerical fault code and fault code description will be displayed on the main screen of the Interface Tool.

If signal is lost to J1939 the EEG7000 reverts to hardwired fixed speed settings (idle).

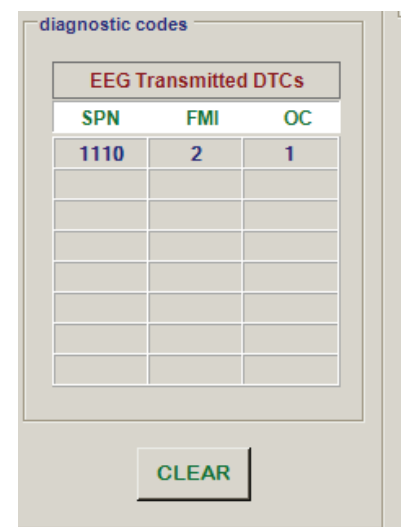

13 J1939 CAN INFORMATION (CONTINUED)

The EEG7000 is J1939 compatible. After initial configuration the CAN data is available on the Faults view on the Interface Tool, or using a compatible controller. Sample PGN transmit and receive codes are shown in this section. This document does not instruct you on using J1939 and CAN.

CREATING J1939 MESSAGING

J1939 messaging between the EEG7000 and the J1939 source is configured using these basics rules.

- J1939 indexing starts at 1, not 0.
- Timeout rate is 2X transmission rate. Transmission rate is configured using SPN3349 (PGN65251), part of the TSC1 message. Timeout rate defaults at the 5th byte (0xFE to 40ms). Other values including SPN3344 can be used to set longer timeouts.
- Speed Ramping is used under one of two conditions:
 - When not under TSC1 control
 - When under TSC1 control and CAN Speed Ramp Enable is set
- Supported PGNs are list in the following sections.

BYTE	1	2	3	4	5	6	7	8
MESSAGE	0xFD	0x00	0x00	0xFF	0xFE	0xFF	0xFF	0xFF
DEFINITION	Speed control mode	Low speed	High speed		Nominal rate 20ms, timeout 40ms			
EXAMPLE	1600 RPM at 20ms nominal (40 ms timeout)							
	0xFD	0x00	0x32	0xFE	0xFF	0xFF	0xFF	0xFF

DATA TRANSMITTED ON J1939 BUS

PGN	NAME	TRANSMIT RATE	VALID SPN's	NOTES
61444	Electronic Engine Control 1 (EEC 1)	20 ms	SPN190 - Engine Speed RPM	
61443	Electronic Engine Control 2 (EEC 2)	50 ms	SPN1 - Accelerator Pedal Position 1 (%) SPN2 - Percent Load at Current Speed (%)	SPN91 is sourced from the variable speed input position. SPN92 is calculated based on no load (NLCU) and full load (FLCU) values.
64914	Engine Operating Information (EOI)	250 ms	SPN3543 - Engine Operating State SPN3607 - Engine Emergency Shutdown	
65252	Shutdown (SHUTDOWN)	1000 ms	SPN2814 - Engine Alarm Output SPN1110 - Engine Protection Shutdown	
65271	Vehicle Engine Power (VEP)	1000 ms	SPN158 - Battery Potential (Voltage), Switched (V DC)	Any system or shutdown condition
65253	Engine Hours, Revolutions (HOURS)	1000 ms	SPN247 - Total Engine Hours	
65216	Service Information (SERV)	1000 ms	SPN916 - Service Delay (Hours)	If the service timer is disabled, SERV will read 0 hours.
65226	Diagnostic Message 1 (DM 1)	1000 ms		Active diagnostic troubleshooting codes, detailed later in this section.
65227	Diagnostic Message 2 (DM 2)	On Request		Previously active diagnostic troubleshooting codes, detailed later in this section.

13 J1939 CAN INFORMATION (CONTINUED)

DATA RECEIVED ON J1939 BUS

PGN	NAME	VALID SPN's	NOTES
0	Torque / Speed Control 1 (TSC1)	SPN695 - Engine Override Control Mode SPN898 - Engine Requested Speed / Speed Limit SPN3349 - TSC1 Transmission Rate SPN4206 - Message Counter SPN4207 - Message Checksum	Engine Override mode not supported (SPN695) system governs at selected speed. After inactivity of 2x transmission rate (SPN3349) the system will revert to governing at the selected speed.
59904	PGN Request	PGN65227 - DM2 (Previously Active Faults) Request PGN65228 - DM3 (Clear Previously Active Faults) Request	

J1939 CAN INFO / DIAGNOSTIC TROUBLESHOOTING CODES (DTC)

SYSTEM FAULTS / J1939 DTC'S

FAULT CODE	CONDITION	J1939 SPN	J1939 FMI	J1939 LAMP / LED DISPLAY	ACTION
1	Actuator Overcurrent	638 (Actuator)	Current High (6)	Protect / Blinking Red	Shutdown, retry 30 seconds
2	Loss of Speed Sensor	636 (Speed Sensor)	Abnormal Signal (8)	Stop / Shutdown	Shutdown
3	Overspeed	190 (Engine Speed)	Data Above Range (0)	Stop / Shutdown	Shutdown
4	User Shutdown	1110 (Eng. Shutdown)	Data Incorrect (2)	Stop / Shutdown	Shutdown
241	EEPROM Read	628 (CPU / Memory)	Out of Calibration (13)	Warning / Solid Yellow	None
285	TSC1 Unsupported Mode	695 (Override mode)	Data Incorrect (2)	Warning / Solid Yellow	Revert to selected speed
286	TSC1 Message Rate Error	3349 (Message Rate)	Data Incorrect (2)	Warning / Solid Yellow	Revert to selected speed
287	TSC1 Message Count Error	4206 (Message Counter)	Data Incorrect (2)	Warning / Solid Yellow	Revert to selected speed
288	TSC1 Speed Request Invalid	898 (Requested Speed)	Data Incorrect (2)	Warning / Solid Yellow	Revert to selected speed
289	TSC1 Invalid Checksum	4207 (Checksum)	Data Incorrect (2)	Warning / Solid Yellow	Revert to selected speed
290	TSC1 Destination Address	1483 (Source Address)	Data Incorrect (2)	Warning / Solid Yellow	Revert to selected speed
305	Service Due	916 (Service Delay)	Data Incorrect (2)	Protect / Solid Yellow	None

14 EEG7000 SYSTEM TROUBLESHOOTING

SYSTEM INOPERATIVE

If the engine governing system does not function determine the fault using the following voltage tests as described in Steps 1 through 3. Positive (+) and negative (-) refer to meter polarity.

- ◆ Should normal values be indicated during troubleshooting steps, then the fault may be with the actuator or the actuator wiring.
- ◆ Perform test with battery power on and engine off, except where noted.
- ◆ See your actuator model's product bulletin for more information on testing the actuator.

VOLTAGE TESTING

STEPS	WIRES	NORMAL READING	ACTION
1	Power 10(-) & 11(+)	Battery Supply Voltage (12 or 24V DC)	<ol style="list-style-type: none"> 1. DC battery power not connected. 2. Check for blown fuse 3. Low battery voltage 4. Wiring error
2	Pick-Up 3 & 12	1.0 V AC RMS min while cranking	<ol style="list-style-type: none"> 1. Gap between speed sensor and gear teeth too great 2. Check Gap 3. Improper or defective wiring to speed sensor. 4. Resistance between 3 and Ground should be 300 to 1200Ω. See your specific magnetic pickup data for resistance settings. Could be defective speed sensor.
3	Actuator & Battery 1(-) & 11(+)	1.0 - 2.0 V DC while cranking	<ol style="list-style-type: none"> 1. SPEED set too low 2. Short/open in actuator wiring 3. Defective speed control 4. Defective actuator. See the product bulletin for the specific actuator and review the Actuator Troubleshooting section.

INSTABILITY

INSTABILITY	SYMPTOM	ACTION
Slow Periodic	An irregularity of speed below 3 Hz. (Sometimes severe)	<ol style="list-style-type: none"> Adjust P, I, and D Check fuel system linkage during engine operation for: <ul style="list-style-type: none"> binding high friction poor linkage Add a small amount of droop.
Non-Periodic	Erratic Engine Behavior	<p>Increasing Stability reduces instability but does not totally correct it. If this is the case, there is most likely a problem with the engine itself.</p> <p>Check for:</p> <ul style="list-style-type: none"> engine mis-firings erratic fuel system load changes on the generator set voltage regulator

UNSATISFACTORY PERFORMANCE

SYMPTOM	RESPONSE	ACTION
Engine Overspeed	Do Not Crank. Apply DC power to the governor system.	After the actuator goes to full fuel, disconnect the speed sensor at Pin 3. If the actuator is still at full fuel-speed then the control unit is defective.
	Manually hold the engine at the desired running speed. Measure the DC voltage between Pins 1(-) & 11(+) on the speed control unit.	<p>If the voltage reading is 1.0 to 2.0 V DC check for:</p> <ul style="list-style-type: none"> Speed set above desired speed defective speed control unit <p>If voltage reading is > 2.0 V DC check for:</p> <ul style="list-style-type: none"> Actuator binding Linkage binding <p>If the voltage reading is below 1.0 V DC check for Defective speed control unit</p>
	Check Flywheel Teeth value.	Incorrect number of teeth entered.
Overspeed shuts down engine after running speed is reached	Examine the Speed and Overspeed values for the engine	<p>Speed set too high.</p> <p>Overspeed set too close to Speed.</p> <p>Actuator or linkage binding.</p> <p>Speed Control unit defective.</p>
Overspeed shuts down engine before running speed is reached	Check resistance between Pin 3 and Ground. Should be 30 to 1200 Ω . See your specific Magnetic Pick-up data for resistance details.	<p>Overspeed set too low</p> <p>If the speed sensor signal is erroneous, then check the wiring.</p>
Actuator does not energize fully	Measure the voltage at the battery while cranking.	<p>If the voltage is less than:</p> <ul style="list-style-type: none"> 7 V DC for a 12 V DC system, or 14 V DC for a 24 V DC system, <p>Then: Check or replace battery.</p>
	Momentarily connect Pins 1 and 11. The actuator should move to the full fuel position.	<p>Actuator or battery wiring in error</p> <p>Actuator or linkage binding</p> <p>Defective actuator</p> <p>Fuse opens. Check for short in actuator or harness.</p>
Engine remains below desired governed speed	Measure the actuator output, Pins 1 and 2, while running under governor control.	<p>If voltage measurement is within 2 V DC of the battery supply voltage level, then fuel control is restricted from reaching full fuel position, possibly due to mechanical governor, carburetor spring, or linkage interference.</p> <p>Speed set too low</p>

Questions?

Contact GAC for assistance
GAC@governors-america.com
or call: 1-413-233-1888