

# ELRi-INTELLIGENT LIQUID RING VACUUM PUMPS



# EDWARDS THE PARTNER OF CHOICE

Edwards is a world leader in the design, technology and manufacture of vacuum pumps for industrial applications with over 100 years' history.

We believe in delivering results that bring value to our customers by using our breadth of industry experience to identify and apply solutions. Using the most innovative and up-to date modelling techniques, we can optimise the pumping configuration for customers to provide a system design giving the maximum performance in the most reliable and cost-effective way.

# PROVEN TECHNOLOGY AND INTELLIGENCE IN A CLEVERLY ENGINEERED PACKAGE

Edwards range of liquid ring pumps continue to provide the optimum solutions for many rough vacuum applications in the chemical and process industries. Built to last, the general reliability and low maintenance of these pumps offer the best solution when it comes to pumping wet gases or particulates.

**We have taken this proven liquid ring technology one-step further. By adding intelligence and an injecting innovation, we have now developed a new range of liquid ring pumps- ELRi series.**

The ELRi is a single-stage, total recovery liquid ring vacuum pump available in pumping capacities - 750, 950 and 1050 m<sup>3</sup>/h. Based on proven Hick Hargreaves technology, the ELRi series is a compact powerhouse with improved performance.

The ELRi is available in two variants – Standard variant with Plates-type heat exchanger and the Heavy-Duty variant with a Tube and Shell heat exchanger for the more corrosive and dirty applications.



# PUMP TECHNOLOGY

Revolutionising conventional Liquid Ring vacuum pump technology.

## RELIABLE AND ROBUST

### Cleverly engineered in a smart design

- Stainless steel impellers and end plates supplied as standard
- Integrated non-return valve protects against backflow



## INNOVATIVE INTERNAL DESIGN

### Highest degree of design build and quality

- Internal injection channels and mechanical seals for a stable sealing arrangement
- Lantern flange arrangement for ease of service



## BUILT-IN INTELLIGENCE

### Twin Variable Speed Drives (VSD) with patented algorithm

- VSD motor with set point control to maintain and match vacuum levels
- VSD for the water circulation pump to optimise water flow and maintain stable vacuum

## HIGH DEGREE OF PROTECTION

### Patented Anti-Cavitation Algorithm

- Prevents the ELRi from operating in areas of cavitation
- Increases pump lifetime, reduces process downtime and maintenance costs

- Set point control
- VSD on main motor
- VSD driven circulation pump
- Spray nozzles
- Cavitation prevention
- Automatic seizure prevention
- Icon box and connectivity



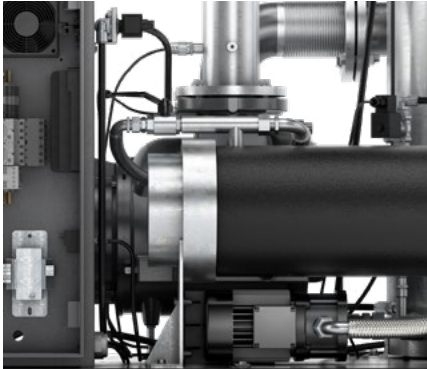

**IP RATED COMPACT CANOPY**

**Compact canopy without sacrificing performance**

- Ergonomically designed IP 54 rated canopy with a small footprint
- Dust and splash-proof with noise containment up to 69 dB

**REMOTE MONITORING VIA ICON BOX**

**Easily identify service requirements and plug gaps**

- ICONS SERVICE - Remote information of machine status
- ICONS UPTIME – Be informed of pump performance and maintenance requirements via SMS/email notification
- ICONS ENERGY - Energy savings report provided monthly

**IDEAL FOR HUMID APPLICATIONS**

**Integrated Spray Nozzles**

- Water spray cools and condenses the inlet gas and vapour from the process
- Reduces energy consumption, increases impeller life and ensures stable pump temperature

**PATENTED ANTI-SEIZURE ALGORITHM**

**Seizure Prevention after long periods of inactivity**

- Automatic turning off the pump for few seconds after long periods of inactivity
- Auto-restart after voltage failure



INTELLIGENCE  
AND AN  
INNOVATIVE  
DESIGN WITH  
AIRLOGIC®  
CONTROL

# ELRi PUMP MAIN COMPONENTS

## Top canopy

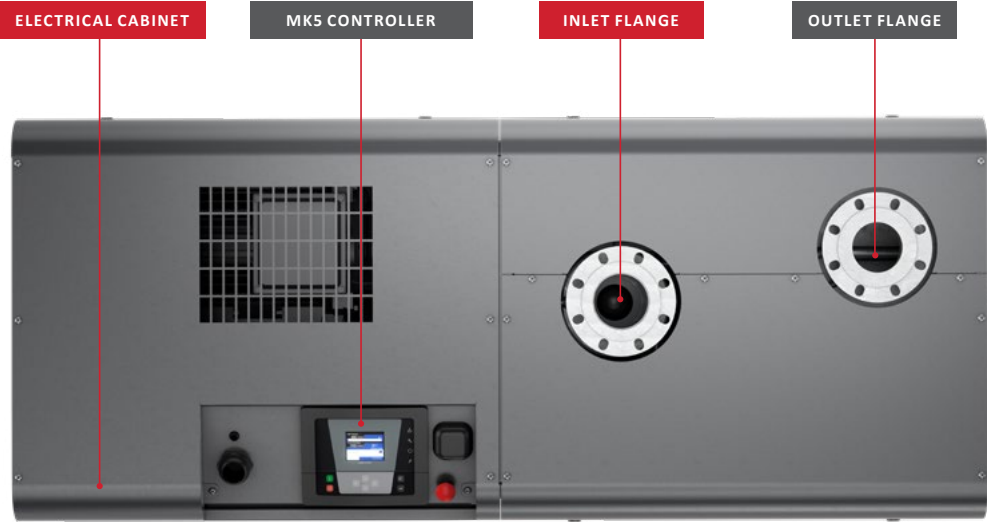

## Internal

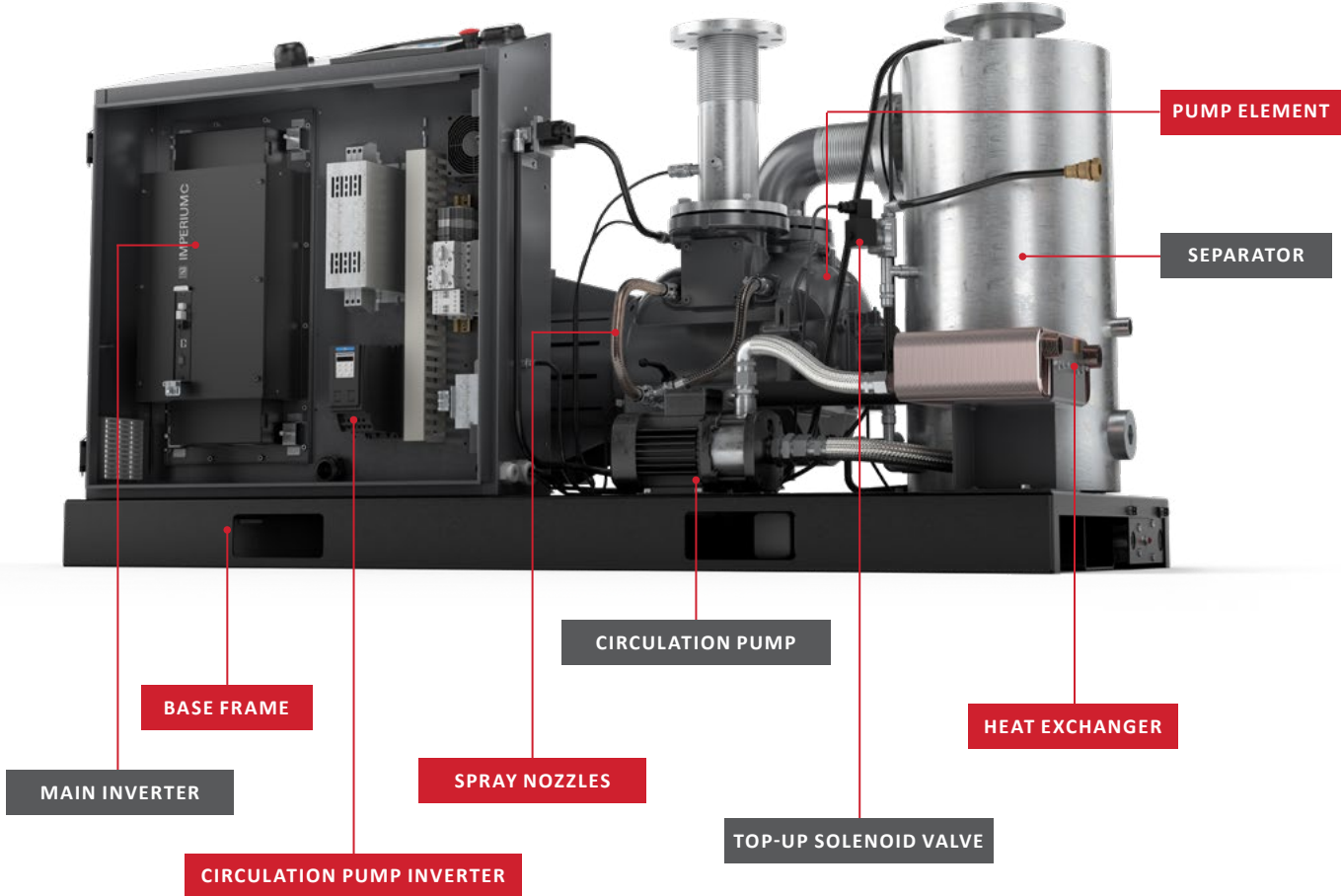

\*For the Heavy Duty ELRi vacuum pump, the plates-type heat exchanger is replaced with the Tube and Shell. The plugs, solenoid valves and connecting pipes are stainless steel. This is suited for the more corrosive and dirty applications.

## ECOControl

---



With our ECOControl Box, you can connect, monitor and control multiple ELRi pumps as well as competitor pumps. You get all the information for the everyday management of your vacuum pump as well as the alarms, safety shutdowns and maintenance:

- **Monitoring:** Vacuum pump operating status, recording of running/stopped hours, programmable timers, temperature/pressure read-outs, set point control and other settings
- **Safety:** Warning indications, fault and shutdown indications
- **Service:** Service operations, remote control (optional)

## Fixed speed versus VSD

---

The need for vacuum fluctuates depending on different factors such as process changes, the time of day, week or even month. The intelligent ELRi can deliver peak performance only when required enabling significant energy and maintenance cost reductions. Optimising the energy used to maintain process vacuum level results in improved process efficiency and performance.

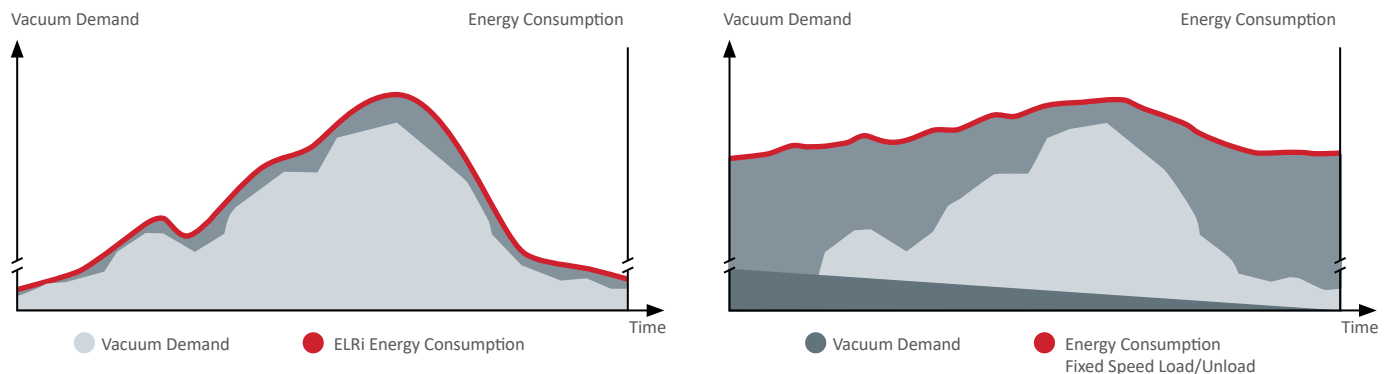

# APPLICATIONS

The ELRi pumps are suitable for a range of applications in various industries including:

- Plastic Extrusion
- Rubber Vulcanisation
- Pulp and paper
- Drying
- Sterilisation
- Evaporation
- Filtration
- Pneumatic Conveying
- Chemical industry
- Pet food industry
- EPS Forming





# PERFORMANCE CURVES

## ELRi PERFORMANCE CURVES

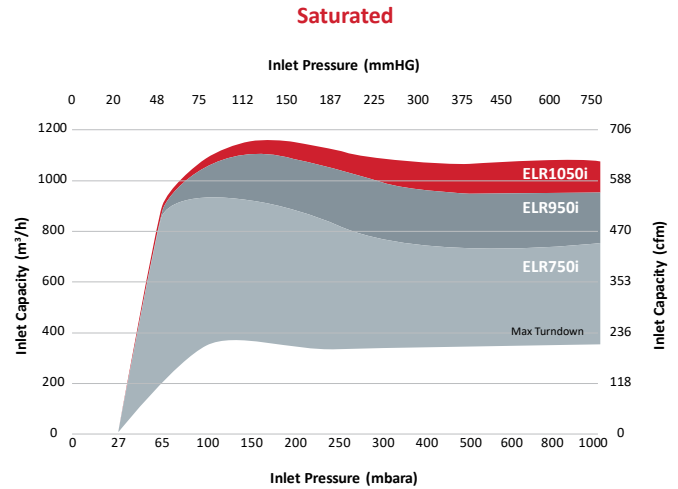
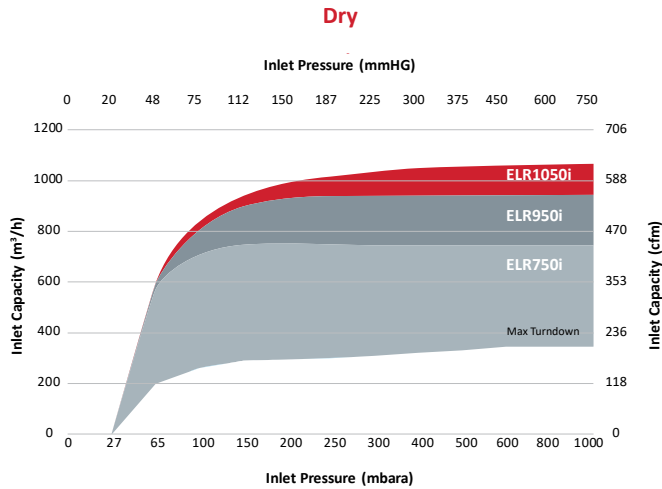

With increased water vapour load

## TECHNICAL SPECIFICATIONS

		ELR750i	ELR950i	ELR1050i
Nominal capacity	Dry-m <sup>3</sup> /h	740	940	1050
	Dry-cfm	436	553	618
	Saturated-m <sup>3</sup> /h	910	1090	1140
	Saturated-cfm	536	642	671
Ultimate pressure(Absolute)	mbar		25	
	inch Hg		0.7	
Nominal installed motor	kW	18.5	26	37
	hp	24.8	34.9	49.6
Footprint (WxDxH)	mm	1950 x 810 x 1020		
	inch	76,8 x 31,9 x 40,2		
	Inlet / Outlet	EN1092-1/01/B1/DN100/PN10		
Connection	Liquid fill / Manual drain	G 1/2" BSP(F)		
	Overflow	G 1/2" BSP(F)		
	Cooler inlet / Outlet	ISO 228/1-G1"		
Dry weight	kg	820	885	900

# DRAWINGS AND DIMENSIONS

Front View

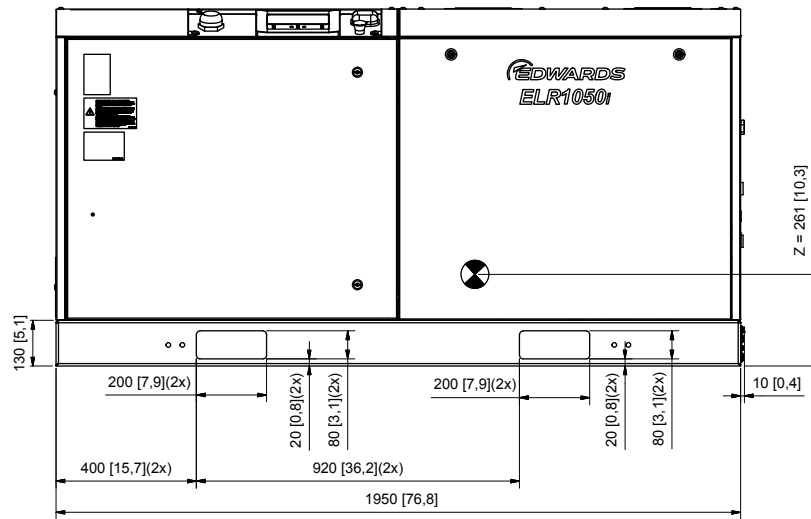

Side View

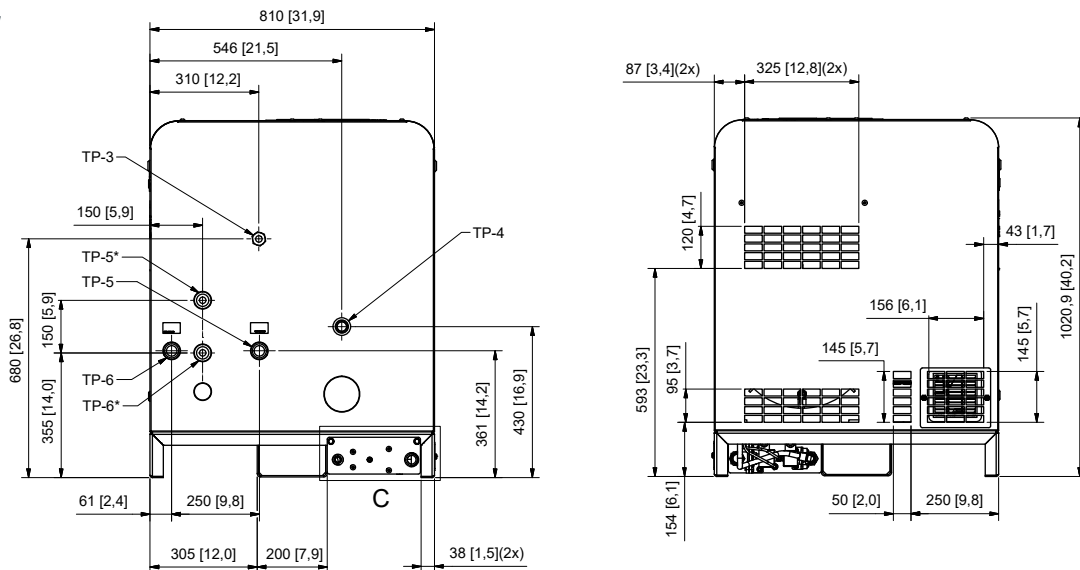

Top View

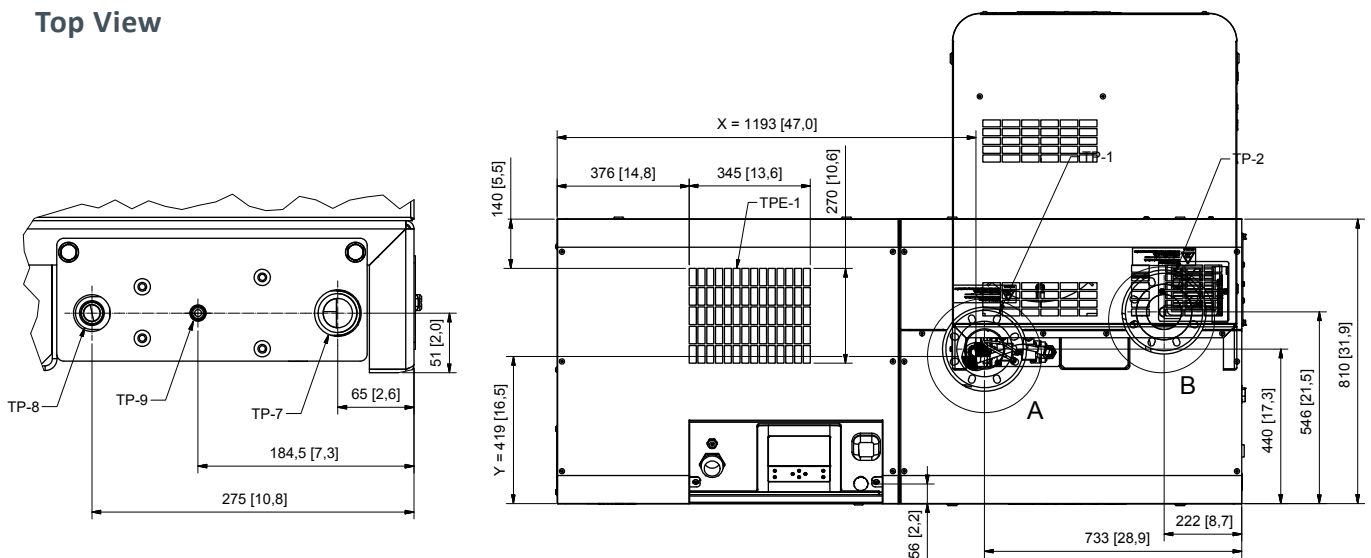

# SERVICE AND SUPPORT

To ensure your ELRi Liquid Ring vacuum pump maintains optimal performance and reliability, we offer a wide range of service solutions, tailored to meet your needs. Our Preventative Maintenance service packages are designed to keep your pump optimised at all times.

Thanks to the incorporated AirLogic® controller and ICON box connectivity, many servicing and maintenance actions can now be performed by the operator. The modular and accessible design of the pump makes these actions simple and saves you time.

## Annual Service

A more comprehensive Annual Service ensures that the heat exchanger and separator remain clean. We fine-tune performance to ensure operating costs are minimised.

## Overhaul

When required, the pump element can be overhauled with the replacement of bearings, port plates and mechanical seals. This can be achieved with minimal impact to you and your operations.

## Spare Parts

Kits are available to aid routine maintenance. Selecting original spare parts ensures reliability is never compromised. Our service engineers only fit 100% genuine parts to ensure you receive the best result from each service provided.



# ORDERING INFORMATION

Part Number	Description
A75167100	ELR 750i Standard
A75167101	ELR 950i Standard
A75167102	ELR 1050i Standard
A75167110	ELR750i Heavy Duty, Stainless Steel version
A75167111	ELR950i Heavy Duty, Stainless Steel version
A75167112	ELR 1050i Heavy Duty, Stainless Steel version
A50862719	ECOntrol6v IEC
A50862720	ECOntrol6v UL,cUL
A50862721	ECOntrol16v IEC
A50862722	ECOntrol16v UL,cUL



## GLOBAL CONTACTS

---

Publication Number: 3602 700 0 01

© Edwards Limited 2020. All rights reserved.  
Edwards and the Edwards logo are trademarks of  
Edwards Limited.

Whilst we make every effort to ensure that we  
accurately describe our products and services,  
we give no guarantee as to the accuracy or  
completeness of any information provided in  
this brochure.

Edwards Ltd., registered in England and Wales  
No. 6124750, registered office: Innovation Drive,  
Burgess Hill, West Sussex, RH15 9TW, UK.

### EMEA

<b>UK</b>	+44 1444 253 000 (local rate) 08459 212223
<b>Belgium</b>	+32 2 300 0730
<b>France</b>	+33 1 4121 1256
<b>Germany</b>	0800 000 1456
<b>Italy</b>	+ 39 02 48 4471
<b>Israel</b>	+ 972 8 681 0633

### ASIA PACIFIC

<b>China</b>	+86 400 111 9618
<b>India</b>	+91 20 4075 2222
<b>Japan</b>	+81 47 458 8836
<b>Korea</b>	+82 31 716 7070
<b>Singapore</b>	+65 6546 8408
<b>Taiwan</b>	+886 3758 1000

### AMERICAS

<b>USA</b>	+1 800 848 9800
<b>Brazil</b>	+55 11 3952 5000