

BT50(T)

Safety relay / Expansion relay



Read and understand this document

Please read and understand this document before using the products. Please consult your ABB JOKAB SAFETY representative if you have any questions or comments.

WARRANTY

ABB JOKAB SAFETY's exclusive warranty is that the products are free from defects in materials and workmanship for a period of one year (or other period if specified) from date of sale by ABB JOKAB SAFETY.

ABB JOKAB SAFETY MAKES NO WARRANTY OR REPRESENTATION, EXPRESSED OR IMPLIED, REGARDING NON-INFRINGEMENT, MERCHANTABILITY, OR FITNESS FOR PARTICULAR PURPOSE OF THE PRODUCTS, ANY BUYER OR USER ACKNOWLEDGES THAT THE BUYER OR USER ALONE HAS DETERMINED THAT THE PRODUCTS WILL SUITABLY MEET THE REQUIREMENTS OR THEIR INTENDED USE. ABB JOKAB SAFETY DISCLAIMS ALL OTHER WARRANTIES, EXPRESSED OR IMPLIED.

LIMITATIONS OF LIABILITY

ABB JOKAB SAFETY SHALL NOT BE RESPONSIBLE FOR SPECIAL, INDIRECT, OR CONSEQUENTIAL DAMAGES, LOSS OF PROFITS OR COMMERCIAL LOSS IN ANY WAY CONNECTED WITH THE PRODUCTS, WHETHER SUCH CLAIM IS BASED ON CONTRACT, WARRANTY, NEGLIGENCE, OR STRICT LIABILITY.

In no event shall responsibility of ABB JOKAB SAFETY for any act exceed the individual price of the product on which liability asserted.

IN NO EVENT SHALL ABB JOKAB SAFETY BE HELD RESPONSIBLE FOR WARRANTY, REPAIR, OR OTHER CLAIMS REGARDING THE PRODUCTS UNLESS ABB JOKAB SAFETY'S ANALYSIS CONFIRMS THAT THE PRODUCTS WERE PROPERLY HANDLED, STORED, INSTALLED, AND MAINTAINED AND NOT SUBJECT TO ABUSE, MISUSE, OR INAPPROPRIATE MODIFICATION OR REPAIR.

SUITABILITY FOR USE

ABB JOKAB SAFETY shall not be responsible for conformity with any standards, codes, or regulations that apply to the combination of products in the customer's application or use of the product. At the customer's request, ABB JOKAB SAFETY will provide applicable third party certification documents identifying ratings and limitations of use that apply to the products. This information by itself is not sufficient for a complete determination of the suitability of the products in combination with the end product, machine, system, or other application or use.

The following are some examples of applications for which particular attention must be given. This is not intended to be an exhaustive list of all possible uses of the products, nor is it intended to imply that the uses listed may be suitable for the products:

Outdoor use, uses involving potential chemical contamination or electrical interference, or conditions or uses not described in this document.

Nuclear energy control systems, combustion systems, railroad systems, aviation systems, medical equipment, amusement machines, vehicles, and installations subject to separate industry or government regulations.

Systems, machines, and equipment that could present a risk to life or property.

Please know and observe all prohibitions of use applicable to the products.

NEVER USE THE PRODUCTS FOR AN APPLICATION INVOLVING SERIOUS RISK TO LIFE OR PROPERTY WITHOUT ENSURING THAT THE SYSTEM AS A WHOLE HAS BEEN DESIGNED TO ADDRESS THE RISKS, AND THAT THE ABB JOKAB SAFETY PRODUCT IS PROPERLY RATED AND INSTALLED FOR THE INTENDED USE WITHIN THE OVERALL EQUIPMENT OR SYSTEM.

PERFORMANCE DATA

While every effort has been taken to ensure the accuracy of the information contained in this manual ABB JOKAB SAFETY cannot accept responsibility for errors or omissions and reserves the right to make changes and improvements without notice. Performance data given in this document is provided as a guide for the user in determining suitability and does not constitute a warranty. It may represent the result of ABB JOKAB SAFETY'S test conditions, and the users must correlate it to actual application requirements. Actual performance is subject to the ABB JOKAB SAFETY Warranty and Limitations of Liability.

Table of Contents

- 1 Introduction 4**
 - Manufacturer information 4
 - Scope 4
 - Prerequisites 4
 - Special notes 4
- 2 Overview 5**
 - General description 5
 - Safety regulations 5
- 3 Function description 6**
 - Safety level 6
 - Internal block diagram 6
 - BT50T – Information output 6
 - BT50T – Delay times 6
- 4 Connections 7**
 - Electrical connection 7
- 5 Connection examples 8**
- 6 Installation 9**
 - Terminals 9
- 7 Operation 10**
- 8 Functional safety 11**
 - Used Directives and standards 11
 - Maintenance 11
- 9 System Structure 12**
 - Assumptions 12
 - Safety Function and Safe State 12
- 10 Functional Safety Data 13**
 - Functional Safety Data BT50(T) 13
- 11 Useful life time 14**
 - Installation and commissioning 14
 - Proof Test procedure 14
- 12 Technical data 15**
 - Model overview 16
 - Dimensions 16

1 Introduction

Manufacturer information

ABB JOKAB SAFETY
Varlabergsvägen 11
SE-434 39 Kungsbacka
Sweden

Scope

The purpose of these instructions is to describe how to use the safety relay BT50(T) in control circuits that are related to functional safety.

Prerequisites

It is assumed that the reader of this document has knowledge of the following:

- Basic knowledge of ABB Jokab Safety products.
- Knowledge of safety devices and process locks.
- Knowledge of machine safety.

Special notes

Pay attention to the following special notes in the document:

 **Warning!** Danger of severe personal injury!
An instruction or procedure which, if not carried out correctly, may result in injury to the technician or other personnel.

Caution! Danger of damage to the equipment!
An instruction or procedure which, if not carried out correctly, may damage the equipment.

NB: Notes are used to provide important or explanatory information.

2 Overview

General description

This manual contains information on using the safety relay in control circuits that are related to functional safety.

The BT50(T) is designed to connect safety devices, such as emergency stops, directly in the voltage supply circuit to the relay. This relay can be used to expand the safety outputs of Pluto.

The relay has three NO safety outputs, one NC output (for monitoring purposes), a test input and complete internal supervision.

In order for the safety outputs to close, the supply voltage, e. g. by means of an emergency stop button, must be connected to A1 and A2 and the test input closed. After actuation of the relay the test input can be opened again.

The test input is intended to supervise that contactors or valves have deactivated before a new start can be permitted. The test input can also be used for starting and the start button can be supervised. (See the connection examples in section 4.)

Safety regulations

 **Warning!** Carefully read through this entire manual before using the device.

The devices shall be installed by a trained electrician following the Safety regulations, standards and the Machine directive.

Failure to comply with instructions, operation that is not in accordance with the use prescribed in these instructions, improper installation or handling of the device can affect the safety of people and the plant.

For installation and prescribed use of the product, the special notes in the instructions must be carefully observed and the technical standards relevant to the application must be considered.

In case of failure to comply with the instructions or standards, especially when tampering with and/or modifying the product, any liability is excluded.

3 Function description

Safety level

The BT50(T) has a double and supervised internal safety function. Power failure, internal component faults or external interference cannot result in dangerous functions.

Input via A1 on its own is not protected from short circuiting, and therefore installation is critical for the safety level to be achieved. To achieve a higher safety level a cable shielded with earth connection can be used at both A1 and A2 (See the connection examples in section 4.) The higher safety level is achieved by fault exclusion at the cables to the A1 and A2 connections, through shielded cables with earth connection or cables protected against damage, e.g. by cable ducting, armoring. The cables connected between connections X4 and A1 need the same protection if installed outside the cabinet. For further information see Table D4 IEC 13849-2:2012.

Steering input only via A2 is only allowed with the failsafe transistor outputs from Pluto PLC.

Internal block diagram

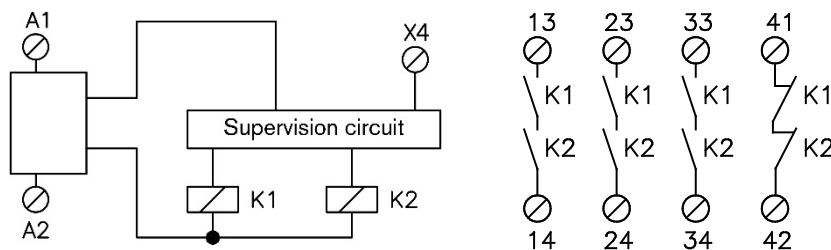

When supply voltage is connected to A1, A2 and X4, relays K1 and K2 are activated. K1 and K2 drop if the supply voltage is disconnected. Both relays K1 and K2 must drop for them to be activated again. The test circuit, A1 – X4, must be closed for the outputs to be activated.. Thereafter A1 – X4 can either be open or constantly closed.

The supervising circuit ensures that both K1 and K2 have dropped before they can be reactivated. The stop function complies with the requirement that a component fault or external interference cannot lead to a dangerous function.

The safety outputs consist of contacts from K1 and K2 connected internally in series across terminals 13 – 14, 23 – 24, and 33 – 34. These contacts are used to cut the power to components which stop or prevent hazardous movements/functions. It is recommended that all switched loads are adequately suppressed and fused in order to provide additional protection for the safety contacts.

The NC output 41 – 42 should only be used for monitoring purposes e. g. indication lamp for emergency stop pressed. The BT50T is the same as BT50 except that it also has delay time selectable outputs and additional information output relay. This is explained in the following connection diagrams.

BT50T – Information output

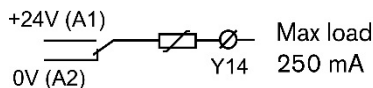

BT50T – Delay times

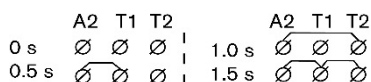

4 Connections

Electrical connection

The inputs from the safety devices must be connected according to one of the following examples in order to fulfil the expected safety level and to avoid unsafe situations.

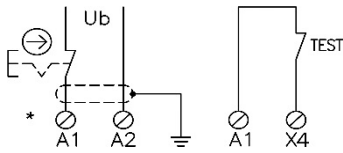

Emergency stop with reset when emergency button returns.

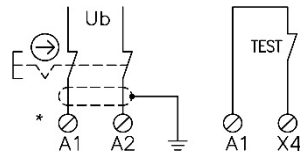

Emergency stop with dual connection direct to the supply voltage.

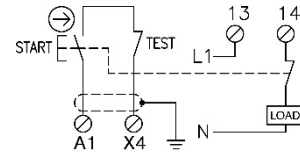

Monitoring to ensure that the On button is not stuck in pressed position. A short circuit over the closing contact is not monitored.

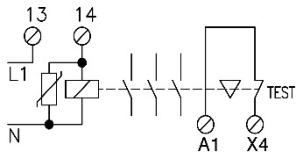

Controlled monitoring of external contactor, relay, valve or Jokab Safety's expansion relays.

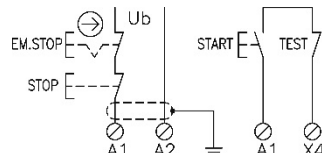

BT50(T) as emergency stop and control relay with Start and Stop function.

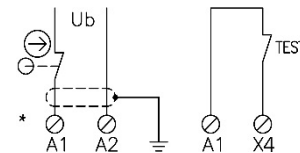

Hatch with automatic reset.

* BT50 has additional power terminals A1 and A2.

5 Connection examples

A) Nödstopps- och manöverrelä med start- och stopp-funktion samt övervakning av yttre kontaktorer/reläer
Emergency stop and control relay with start/stop-function and monitoring of external contactors/relays

B) Nödstopps med dubbla kontakter, aut. återställning.
Emergency stop with dual contacts and autom. reset

C) Lucka med automatisk återställning
Interlocked hatch with automatic reset

D) Lucka med manuell start (ej övervakad återställning)
Hatch with manual start (no supervised reset)

E) Expansion med automatisk återställning
Expansion with automatic reset

OBS/NOTE:
1) START-knappen ej övervakad
START pushbutton not supervised
2) START-knappen delvis övervakad
START pushbutton partly supervised

***)** OBS: Använd alltid transient skydd t.ex. VDR!
***)** NOTE: Always use transient suppressors, e.g. VDR's!

****)** OBS: Kabelskydd beskrivs i avsnittet Säkerhetsnivå i manualen. Inkopplings exempel visas i manualen.
****)** NOTE: Cable protection is described in the Safety Level section in the manual. Electrical connection examples are shown in the manual.

Anmärkning Remark	Konstr. Design	Code	Appr.	Datum Date	Blad Sheet
ANSLUTNINGSEXEMPEL BT50 CONNECTION EXAMPLES BT50	JS	JS	JS	20070823	1
	Ritad Drawn	Sidor Pages	Ritn nr Drawing no	HA6500B	Forts Cont
	JS	1			

A) Nödstopps- och manöverrelä med start- och stopp-funktion samt övervakning av yttre kontaktorer/reläer
Emergency stop and control relay with start/stop-function and monitoring of external contactors/relays

B) Nödstopps med dubbla kontakter, aut. återställning.
Emergency stop with dual contacts and autom. reset

C) Lucka med automatisk återställning
Interlocked hatch with automatic reset

D) Lucka med manuell start (ej övervakad återställning)
Hatch with manual start (no supervised reset)

E) Expansion med automatisk återställning
Expansion with automatic reset

F) BT50T Info utgång
BT50T Info. output

G) BT50T Fördröjningstider
BT50T Delay times

OBS/NOTE:
1) START-knappen ej övervakad
START pushbutton not supervised
2) START-knappen delvis övervakad
START pushbutton partly supervised

***)** OBS: Använd alltid transient skydd t.ex. VDR!
***)** NOTE: Always use transient suppressors, e.g. VDR's!

****)** OBS: Kabelskydd beskrivs i avsnittet Säkerhetsnivå i manualen. Inkopplings exempel visas i manualen.
****)** NOTE: Cable protection is described in the Safety Level section in the manual. Electrical connection examples are shown in the manual.

Anmärkning Remark	Konstr. Design	Code	Appr.	Datum Date	Blad Sheet
ANSLUTNINGSEXEMPEL BT50T CONNECTION EXAMPLES BT50T	JS	JS	JS	20070823	1
	Ritad Drawn	Sidor Pages	Ritn nr Drawing no	HA6501B	Forts Cont
	JS	1			

NB: More connection examples can be found at www.abb.com/jokabsafety or in the Safety Handbook.

6 Installation

Attach the BT50(T) on a 35mm DIN rail and use the information in section 4 'Connections' in this manual to connect power supply and safety devices for your need.

Terminals

The connection block is detachable without cables having to be disconnected.

Maximum screw torque: 1 Nm

Maximum connection area:

Solid: 1 x 4 mm² / 2 x 1.5 mm²

Stranded ferruled: 1 x 2.5 mm² / 2 x 1.5 mm²

Air and creep distance 4 kV/2 IEC 60664-1

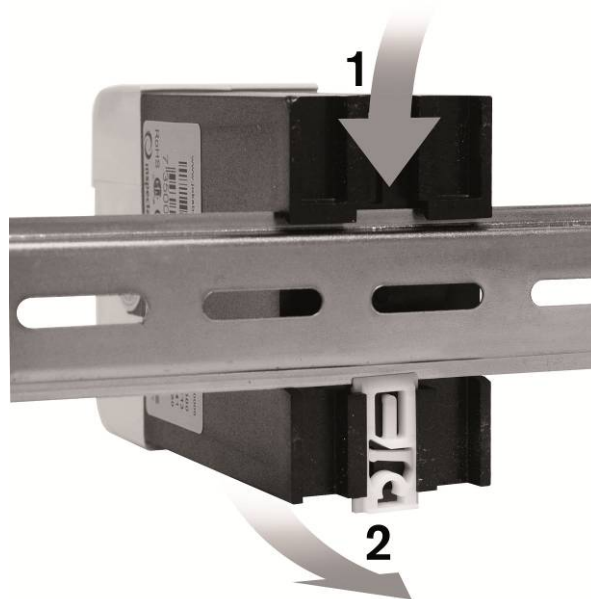

Caution! The main voltage for the system should be switched off before installation, modifications or other adjustments that can risk the safety of the system.



NB: The picture does not show the actual product.

7 Operation

LED indication

On 	LED is on when Supply voltage is OK.
Out 	LED is on when the safety outputs are activated.
X4	Led is on when auto-reset condition is fulfilled.

8 Functional safety

Used Directives and standards

Device specific directives and standards

- Machinery Directive 2006/42/EC
- EMC Directive 2004/108/EC
- Low Voltage Directive 2006/95/EC
- EN 61508-1/...-7:2010
- EN ISO 13849-1:2008
- EN 62061:2005
- EN 60664-1:2007
- EN 61000-6-2:2005
- EN 61000-6-3:2007
- EN 60947-5-1

Maintenance

In case of functional problems: Test the safety functions and devices. The entire system should be tested without disconnecting the power supply. Check that the LED indicator "On" for the power supply is lighting. To get the safety outputs On, the auto-reset connection X4 must be connected to A1. The LED indicator "X4" lights On followed by the LED indicator "Out". The "Out" LED lights when the safety outputs are On. The safety outputs of the BT50(T) open when the power supply is disconnected at A1, A2 or both A1 and A2(Read the Safety Level information at chapter 3). The safety outputs of the BT50T can be time delayed. In case of a problem with the unit, check the LED status and inspect the appropriate part of the system. Take measurements where necessary. If the problem is not solved, then contact the nearest ABB Jokab Safety Service Office or reseller.

 **Warning!** The safety functions and the mechanics shall be tested regularly, in high-demand mode at least once every year to confirm that all the safety functions are working properly (EN 62061:2005).

 **Warning!** In case of breakdown or damage to the product, contact Jokab Safety and replace it with a similar product. Do not try to repair the product yourself since it may accidentally cause permanent damage to the product, impairing the safety of the device which in turn could lead to serious injury to personnel.

Certificate

EC Type Examination Certificate no. 44 205 11 400306-003
ABB library no. 2TLC172068D0401

9 System Structure

Assumptions

The following assumptions have been made during the FMEDA analysis:

- The device shall claim less than 35% of the total failure budget for a SIL3 safety loop.
- Failure rate based on the Siemens SN29500 standard. 2004-01
- Failure rates are constant, wear out mechanisms are not included.
- External power supply failure rates are not included.
- The safety-related device is considered to be of type A components with a Hardware Fault Tolerance of 1.
- It is assumed that the device will be used under average industrial ambient conditions according to the technical data.

Safety Function and Safe State

Safety Function

When the input of the BT50 is de-energized, the output is de-energized. When the input of the BT50T is de-energized, the output is de-energized according to the time settings.

Safe state

The safe state is when all three NO safety outputs are de-energized.

Switching Frequency

The maximum switching frequency in the safety relevant input is 0,3 Hz.

10 Functional Safety Data

Functional Safety Data BT50(T)

Parameters acc. to IEC 61508	Values
Device type	A
Mode of operation	Low Demand Mode or High Demand Mode
HFT	1
SIL	3
Safety function	Output relays in OFF state when input is de-energized
λ_s	8126 FIT
λ_{dd}	0 FIT
$\lambda_{du} = \lambda_d$	12.2 FIT
λ_{tot}	8138.2 FIT
SFF	99,8%
MTTF _d	9337 years
PFH	1.22×10^{-8} 1/h
PFD _{avg} for T _{proof} = 1 year	5.25×10^{-5}
PFD _{avg} for T _{proof} = 2 years	1.09×10^{-4}
Response time at deactivation	< 20 ms
Life Time	20 years

The function of the devices has to be checked within the proof test interval (T_{proof}).

11 Useful life time

For the calculation of the Functional Safety data a constant failure rate had been assumed. This only applies if the useful lifetime of the components is not exceeded. The failure rates have been calculated according to worst case stress region for inductive load, DC. The output relays in BT50(T) have a mechanical life time of 10.000.000 cycles.

Installation and commissioning

During installation all aspects regarding the SIL level of the loop must be considered. The safety function must be tested to ensure the expected outputs are given. When replacing a device, the loop must be shut down. In all cases, devices must be replaced by the same type.

Proof Test procedure

The Proof Test is a periodic test performed to detect hidden faults in a safety-related system.

According to IEC 61508-2 a periodic proof test shall be realized in a safety related system to reveal potential dangerous faults that are otherwise not detected by diagnostic test.

The Proof Test is realized when the safety related system is used in Low Demand Mode. The safety function is only performed on demand, in order to transfer the Equipment Under Control (EUC) into a specified safe state, and where the frequency of demands is no greater than one per year.

Procedure

1. Verify that the operational voltage is according to the product specifications.
2. The safe state at this safety relay is when all the safety outputs are open. With no power connected to the safety outputs, it must be verified a high resistance state at each safety output. This can be measured with an ohmmeter (without special accuracy). The high resistance is showed as "OL" view at a digital display. The safety outputs are 13 – 14, 23 – 24 and 33 – 34. The safe state must be achieved when the system is tested. All the safety devices that control the input/power A1 – A2 must be tested. The test must verify that all the safety outputs are open, which is in safe state, when the power to the input/power A1 – A2 is disconnected.
3. Applying voltage to the input/power A1 – A2 and X4 energizes the safety relay outputs to the closed position. Test that when the connection X4 is disconnected the safety relay outputs remain open when applying voltage to input/power A1 – A2. Verify the Start button function when used in the circuit.

Perform the proof test on the complete safety system, as many times as required, to verify that it works properly.

Only if all tests are successful, the proof test is passed.

12 Technical data

Manufacturer

Address	ABB JOKAB SAFETY Varlabergsvägen 11 SE-434 39 Kungsbacka Sweden
---------	--

Power supply

Operational voltage	+24 VDC +15 %/-25 %
Power consumption	< 2 VA
Relay outputs	3 NO + 1 NC

Max. switching capacity

Resistive load AC	6 A/250 VAC / 1500 VA
Inductive load AC	Utilization category AC-15: 240 VAC / 2 A
Resistive load DC	6 A/24 VDC / 150 W
Inductive load DC	Utilization category DC-13: 24 VDC / 1 A
Max. total switching capacity	12 A distributed on all contacts
Min. load	10 mA/10 V (if load on contact has not exceeded 100 mA)
Contact material	AgSnO ₂ + Au flash

General

Fuses output (external)	5 A gL/gG	
Conditional short-circuit current (1 kA)	6 A gG	
Max. input wire res. at nom. voltage	200 Ω	
Response time	When deactivating (input-output)	<20 ms or delayed (BT50T) max 1500ms
Degree of protection	Enclosure Connection blocks	IP 40 IEC 60529 IP 20 IEC 60529
Operating temperature range	-10°C to 55°C	
Operating humidity range	35% to 85% (With no icing or condensation)	
Impulse Withstand Voltage	2.5 kV	
Pollution Degree	2	
Weight	200 g	
Colour	Light grey and dark grey	

Model overview

Type	Article number	Description
BT50	2TLA010033R0000	BT50
BT50T	2TLA010033R1000	BT50T

Dimensions

NB: All measurements in millimetres.

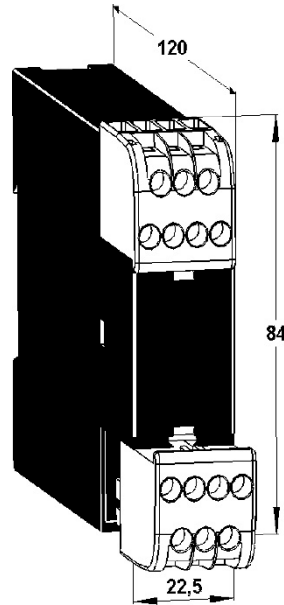

Connector blocks are detachable
(without cables having to be disconnected)