

ThermCAM-80

Economic & Modern Day Alternative
For Spot Temperature Measurement
IR Thermometer

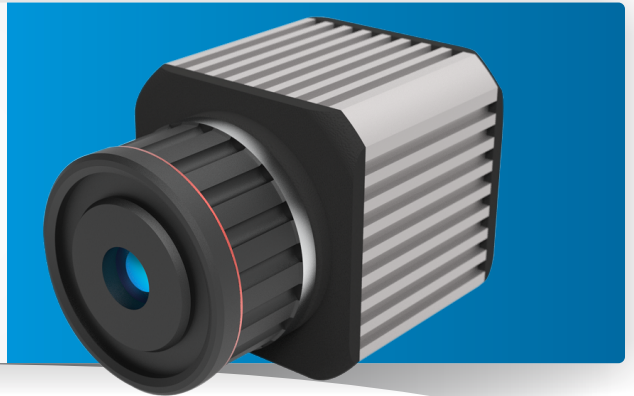

ThermCAM-80 Thermal imaging camera offers a broad range of applications across several industries. Currently industries are using spot temperature pyrometers to measure temperature of a critical points. ThermCAM-80 can replace such pyrometers with better area coverage and will also give individual pixel temperature. Also ThermCAM-80 has an advantage of showing the thermal image which makes it more suitable for continuous monitoring of critical assets. High resolution, like 640x480 pixels is not always needed in industrial applications. Sometimes we just need to identify faults. So ThermCAM-80, 80x80 pixels, is the most economic solution.

Product Highlights

- ThermCAM-80 works at LWIR range from 8 - 14 μm @25 fps.
- Provide continuous thermal video in InfraView Software in PC as well as in I/O Module.
- High shock and vibration tolerance for maintenance-free operation.
- Multiple ThermCam can be (upto 3) connected to single InfraView Software presently.
- Low power consumption working at 12 to 28 VDC.

Typical Applications

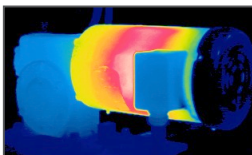

Critical Assets

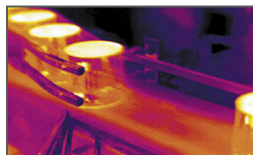

Process Automation

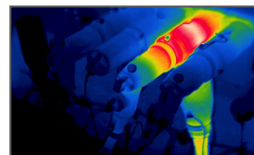

Electric Equipment Inspection



Conveyer Belt Monitoring

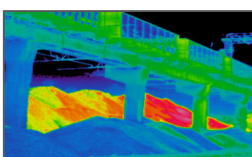

Early Fire Detection

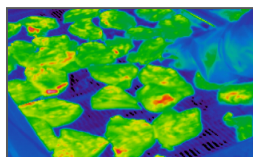

Quality Management



HVAC Inspection



Research and Development

Temperature Ranges

- -20°C to 120°C
 - 100°C to 1000°C
- } Switchable via Software

Detector

Uncooled FPA detector with 80 x 80 pixels resolution

Measurement Accuracy

$\pm 2\%$ of reading in $^{\circ}\text{C}$ or $^{\circ}\text{K}$ (Ambient temp @25 $^{\circ}\text{C}$)

Software Features

- Different Types of ROI for localized temperature monitoring
- Histogram and Trend Chart of ROI
- Configurable Audio/Visual Alarm.

Output Interface

- Fast thermal data acquisition in real time via 100M-bit Ethernet with built-in 4-20mA, TTL o/p.
- I/O cards for additional analog, digital o/p.

ThermCAM-80

Overview

The compact design of the ThermCAM-80 enables the integration of the camera into compact process applications, while the durable and robust housing guarantees reliability even in harshest industrial environments. The ThermCAM-80 can be installed with an optional water/air cooled enclosure for additional protection in harsh industrial environments where ambient temperatures exceed $\sim 50^{\circ}\text{C}$.

The built-in 100M-bit Ethernet interface (GigE) allows the camera to be connected to the network for high speed data transmission to InfraView™ software for further analysis.

Optics Variants

ThermCam-80 comes with standard 5.56mm lens. The table and picture show the correlation between the measurement distance and the size of the measurement fields.

Measurement Field (HFOV x VFOV)	Distance of object	Width (m)	Height (m)	Pixel WxH (mm)
28° x 28° (FL = 5.56 mm)	1 M	0.49	0.49	6.23
	5 M	2.44	2.44	31.17
	10 M	4.89	4.89	62.13

Note : Other lens options are also available as per application requirements.

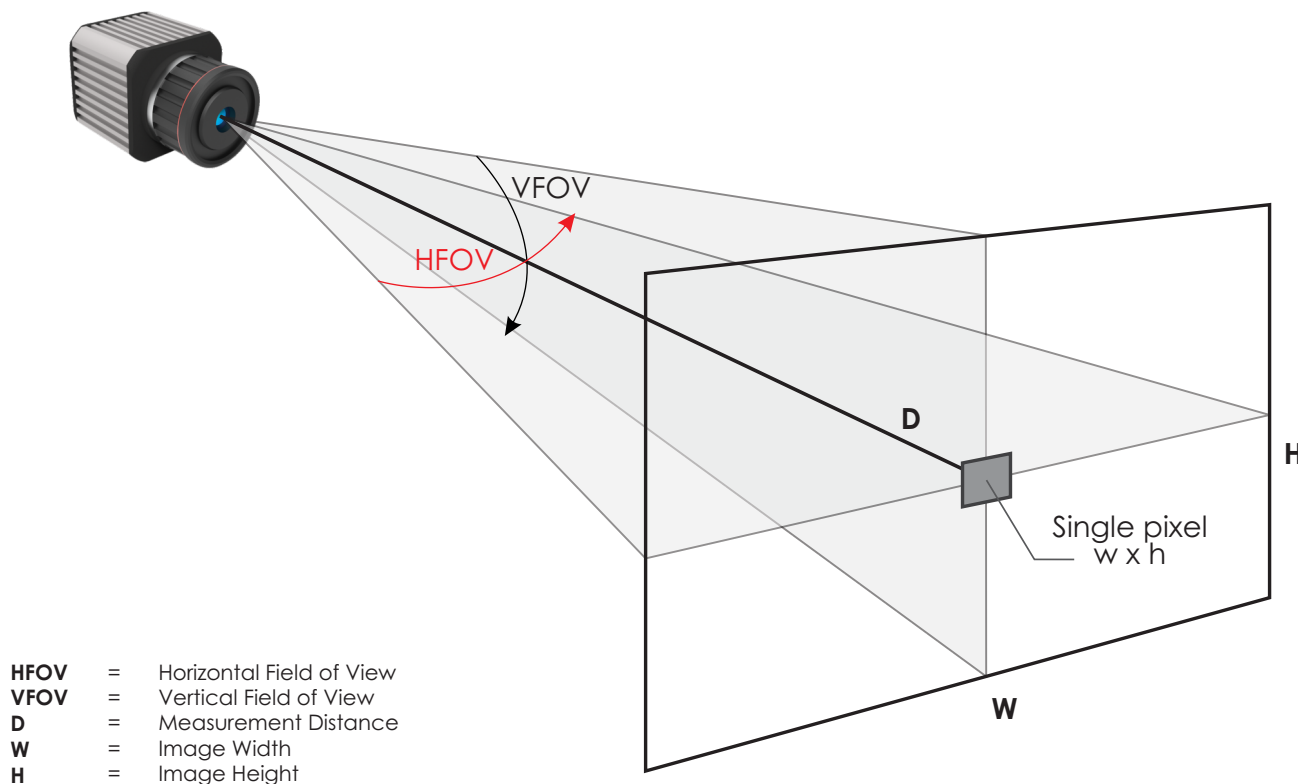

SYSTEM CONFIGURATION

Accuopt thermal imagers offer several configuration options.

ThermCAM-80 Over Network

The system can be set up by connecting the camera directly to a dedicated computer using Ethernet connection which can be extended for remote access/intranet. Also camera can be paired with a network device (switch) which can be further connected with I/O module to get alarm/alerts, analog/digital output for digital indicator and PLC/SCADA systems.

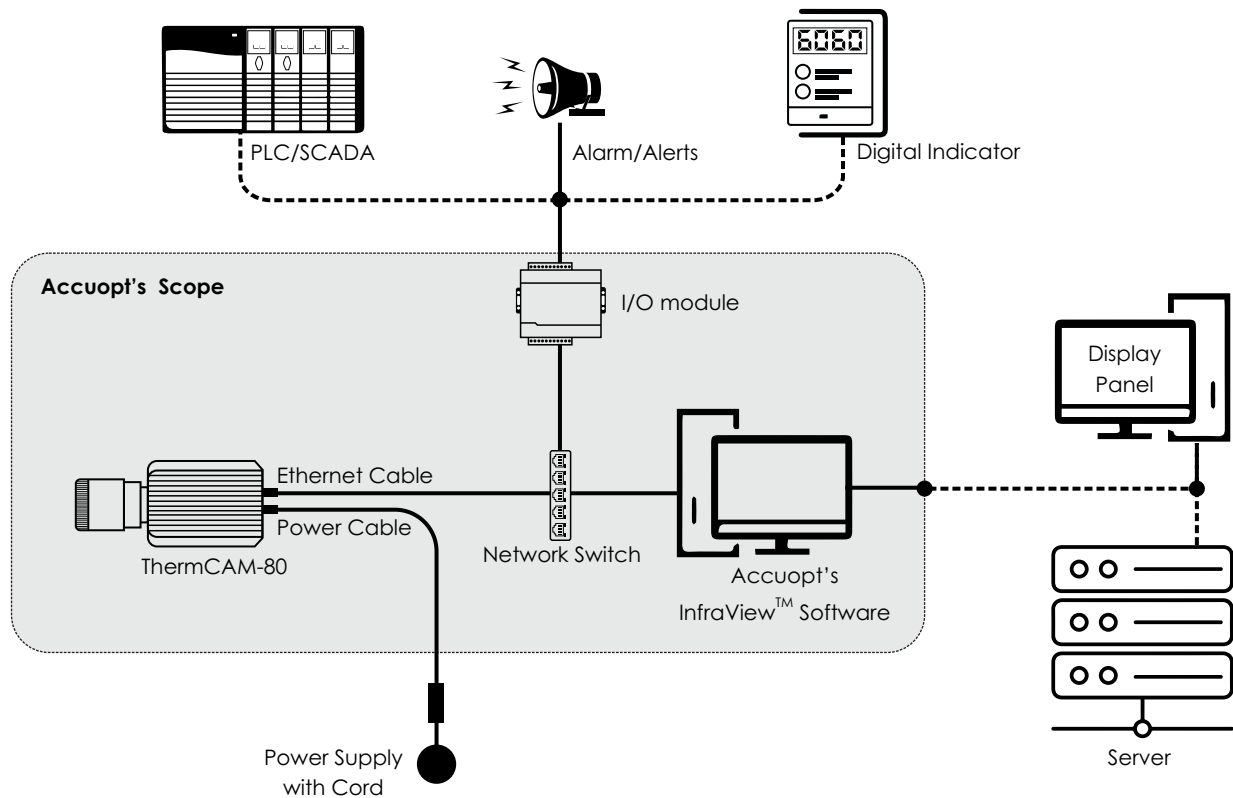

ThermCAM-80 Standalone System

Additionally, the camera can be used with a desktop PC or with a laptop for a standalone monitoring system.

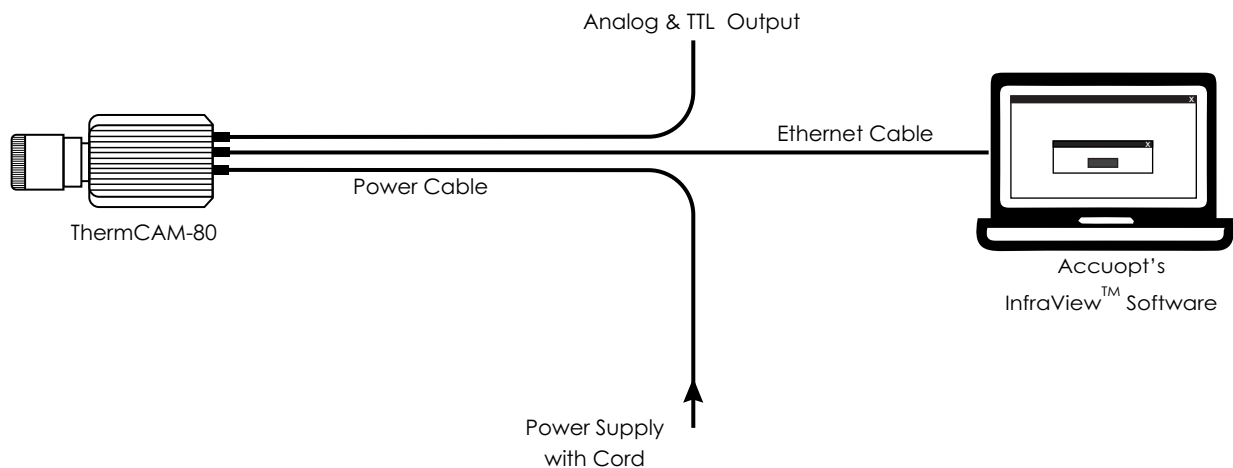

ThermCAM-80 has a thermal image processing software INFRAVIEW™ at the core of a thermal imaging system which is MS Windows based standard Image Processing Software that comes with many useful features.

Accuopt's INFRAVIEW™ software allows you to control the camera record, record thermal video, stream video nearly real time, It allows computed temperatures to be sent out via I/O card which in turn can be connected to PLCs

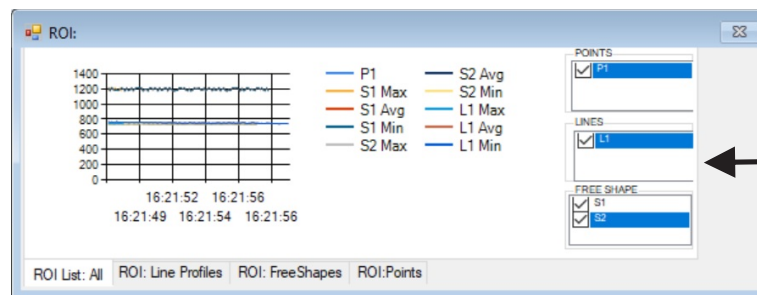
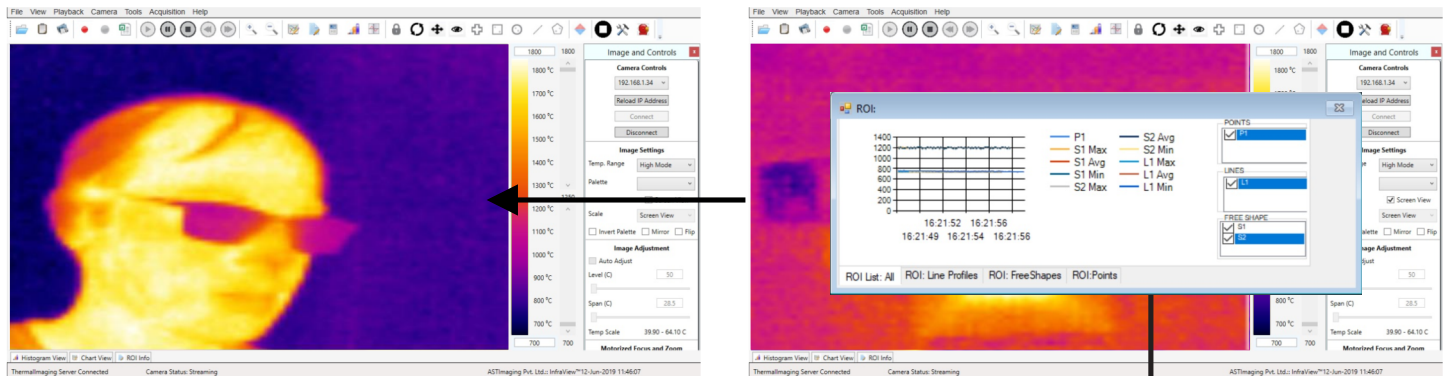

SALIENT FEATURE LIST FOR INFRAVIEW™ SOFTWARE

- Configurable emissivity, Transmissivity Settings
- Real-time display of thermal images
- Includes 9 different color palates
- Multiple types of ROI including point, line, and area with min./max./avg. temperature display
- Includes analysis tools like histogram and temperature trend chart for multiple ROI's.
- Alarm generation for entire or ROI based on minimum, maximum or average temperature
- Analog and digital output module
- Triggered capture based on alarm conditions
- Password controlled user access
- Data export to text or Microsoft Excel (includes thermal image, ROI table summary/data, image data) or to text
- Analyze previously recorded images using RAW data
- Saving Thermal Video in MP4 format
- Optional SDK
- Additional software for Real Time Temperature dashboard, analysis and report generation.

STANDARD ACCESSORIES

- 12 VDC Power Cord
- Ethernet Cable 10Mtr.
- Standard Infraview™ Software
- Lens

OPTIONAL ACCESSORIES

Water Cooling Jacket with Air Knife

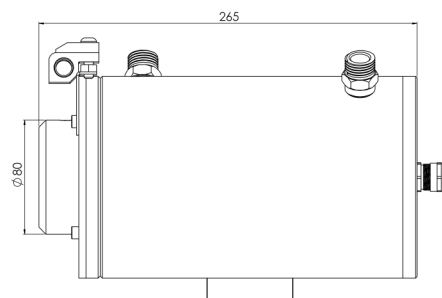
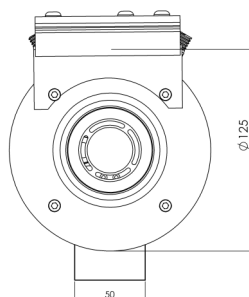

I/O Module



DIN RAIL Mounted I/O Module

The I/O module consist of digital input/digital output(relay output) and analog 4 - 20mA. It provides analog and relay outputs with respect to temperature. These outputs can be customized for temperature indication, alarm generation or error reporting.

- All I/O are user settable for range and ROI selection
- I/O can be customized according to user requirement
- I/O works on Ethernet and provide with Din rail Mounting for Easy Installation

Workstation/Laptop



- Processor : Intel i5 8th Generation or Higher
- RAM : 8 GB
- HDD : 1 TB or Higher
- SSD : 256GB
- 2 Gigabit Ethernet port
- Operating System : Windows 10Pro

Wall Mounting

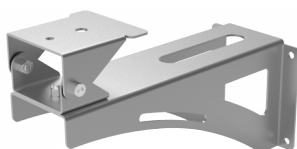

Vortex Tube



Network Devices



TECHNICAL DATA

Performance Specifications	
Temperature Range	-20°C to 120°C 100°C to 1000°C (Switchable)
Optional Resolution	80 x 80 pixels
Detector	Uncooled FPA Detector
Frequency	@25Hz
Emissivity	0.01 - 1.0 adjustable
Accuracy	±2% of reading in °C or °K (Ambient temp @25°C)
Spectral Range	8 to 14 μm
Sensitivity / NETD	<100mK@f1.0, 50Hz 300 K
Pixel Pitch	35 μm

Interface Specifications	
Video	100MBit/s Ethernet
Connection	Power Connector, RJ-45 Ethernet Connector
Output	4 - 20mA 1 TTL output
Video Format for Saving	MPEG-4
Image Format for Saving	BMP/JPEG

Electrical Specifications	
Power Supply	12 to 28 V DC
Power Consumption	4 Watt Max.

Environmental / Mechanical Specifications	
Ambient Temperature	0°C - 50°C
Storage Temperature	-40°C - 70°C
Relative Humidity	≤95% non-condensing
Shock Resilience	25g
Vibration Resilience	2g
Weight	~550g
Protection Class	IP65
Size	95 x 60 x 60 mm
Mounting	1/4" UNC, 3/8" UNC

Cooling Jacket Specifications	
Inlet/Outlet (Cooling)	1/2" NPT Thread
Inlet For Air Purging	PU Pipe suitable for 6mm nozzle
Water Flow Rate	6-8 L/min
Air Pressure	Min. 3 bar (Moist Free)
Mounting	1/4" UNC, 3/8" UNC

Additional I/O Module Specifications	
Analog Output	4 Channel Analog Current Output (4 - 20mA)
Digital Input	2 Isolated Inputs
Digital Output	2 Relay Outputs
Power Supply	5 V DC

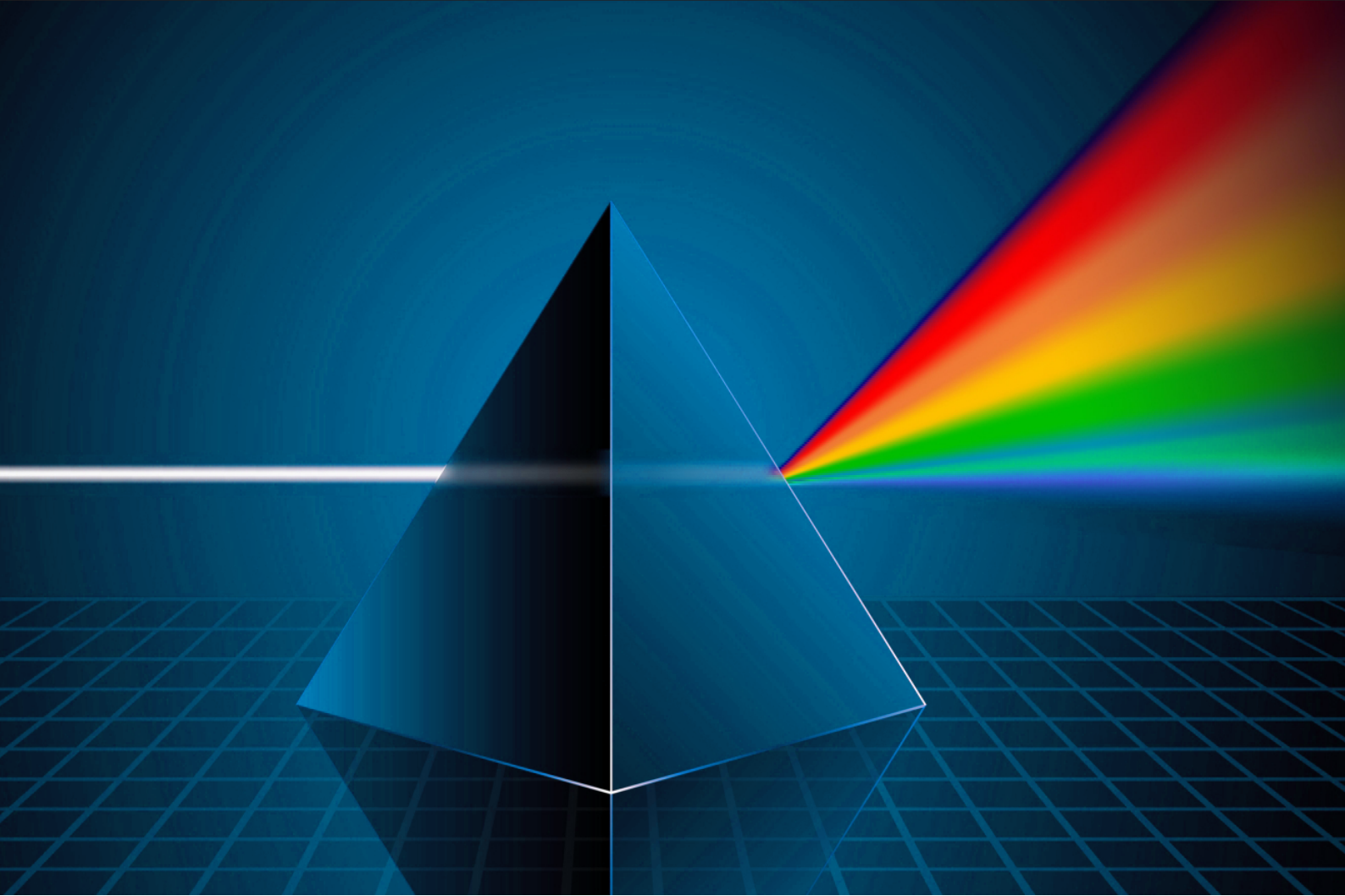

for any information,
visit www.accuopt.com

info@accuopt.com
+919352506032, +91 8306006472

ABOUT ACCURATE OPTOELECTRONICS

AccuOPT – Accurate Optoelectronics Pvt Ltd. is a world-leading manufacturer of thermal imaging camera and solution. Based on technological innovations, AccuOPT Technology offers parts or end-to-end solutions for Industrial, Defense, Surveillance and Medical fields.

Specifications are subject to change without notice. Not responsible for errors or omissions. Accurate Optoelectronics Private Limited.