

Installation manual Drummotor



Van der Graaf
Power Transmission Equipment

www.vandergraafpte.nl

In the interest of development and improvement of our products, we reserve the right to carry out design and specification changes without notice.

© 11/2011 Van der Graaf B.V.

Contents



Installation manual			Page 4
Installation		4	
Mounting	4		
Terminal box	4		
Electrical connection	4		
Maintenance		14	
Maintenance procedure	14		
Changing the oil	14		
Recommended oil types	15		
Oil quantity	16		
Parts		22	
Trouble-shooting		25	
Contact us		26	

en



Installation

Mounting

The Drummotor should be mounted horizontal, square to the frame of the conveyor and parallel with the tail drum. The drummotor can be mounted at the head end as well as at the tail end of the conveyor. The indented arrow on the mounting shaft opposite the terminal box (or cable entry) end must point upwards (refer to Fig. 1).

This installation procedure ensures that the rotating internal parts are adequately submerged in oil. Any deviations from this position are allowed up to an angle of approximately 40°. Should the angle exceed 45° the Drummotor fixing shafts should be re-positioned to follow the above requirements.

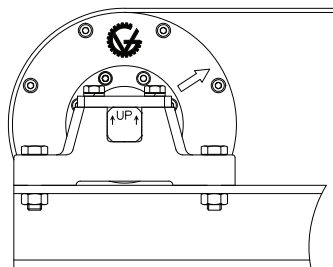

Fig. 1

Warning:

The conveyor belt must never be over-tensioned. Too much tension on the belt could cause internal damage of the Drummotor.

Terminal box

The terminal box can be turned from the standard mounted position (Cable entry downwards) around the fixed shaft once the adjusting screw(s) Pos. 27 (refer to page 20-22) has been loosened.

The degree of rotation is strictly limited to 90° CW and 90° ACW.

Electrical connection

In order to ensure that the Drummotor is properly electrically connected, refer to the enclosed circuit diagrams on pages 6-13. Remember that the 'Delta' voltage is always the lowest voltage shown on the data plate. Always have the Drummotor connected by qualified personnel in accordance with local and national regulations and safety instructions. The Drummotor must be installed with the correct protection against 'overload', (eg. thermal overloads, in-line fuses, etc.). The full load current rating (FLC) of the motor is shown on the stainless steel data plate mounted on one of the Drummotor endcaps or on the terminal box. Before connection, ensure that the electrical supply/frequency is in accordance with the information on the motor dataplate. If the Drummotor is fitted with a GV Therm Thermistor (resistance device) or GV Therm Klixon (Bi-metallic switch N-C), these should be connected into a suitable circuit to provide additional 'over-heating' protection of the motor winding.

Attention:

If the Drummotor is fitted with a backstop (anti-run back device), refer to the instructions on page 5. If the Drummotor is fitted with an electromechanical brake, refer to the circuit diagram enclosed, or the diagrams shown on pages 11-13.

Activating the power supply:

1. Check that the Drummotor is connected correctly (see above) and is suited for the supply voltage/frequency available on site.
2. Check that the Drummotor and conveyor belt are free to move.
3. In case the Drummotor is fitted with a backstop, check that the Drummotor runs in the correct direction.



Connecting a terminal box Drummotor with an internal backstop (TBLH/TBRH)

1. Observe the arrow on the endcap of the drum. This indicates the direction of 'free' rotation of the Drummotor (refer to Fig. 2).
2. Ensure a correct earth connection.
3. Connect the terminal board in star or delta according to the supply voltage and the information on the Drummotor data plate.
4. Connect the three phase (3PH) supply as follows: Connect L1 to U1 of the terminal board, connect L2 to V1 and L3 to W1.
5. Switch the power supply on for no longer than 1/2 second. If the Drummotor turns, the phase rotation is correct. If the Drummotor does not turn, switch off immediately and reverse two phases; Eg: Connect L1 to V1 and L2 to U1.
6. Switch the power supply back on. The Drummotor will now run in the correct direction.

Connecting a cable Drummotor with an internal backstop (TBLH/TBRH)

1. Observe the arrow on the endcap of the drum. This indicates the direction of 'free' rotation of the Drummotor (refer to Fig. 2).
2. The cores are coded with numbers. For these codings refer to the drawings on page 9-10.
3. Ensure a correct earth connection.
4. Connect the power supply to the cores according to the correct drawing.
5. Switch the power supply on for no longer than 1/2 second. If the Drummotor turns, the phase rotation is correct. If the Drummotor does not turn, switch off immediately and reverse two phases; Eg: L1 and L2.
6. Switch the power supply back on. The Drummotor will now run in the correct direction.

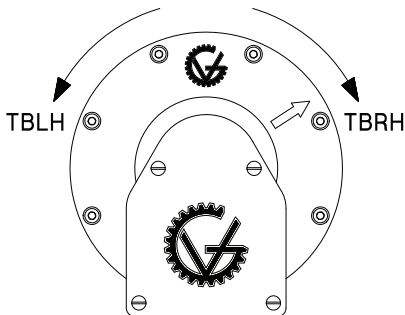

Fig. 2



Installation

3-phase motor fitted with terminal box

3-phase power supply: 230/400 Volt - 50 Hz

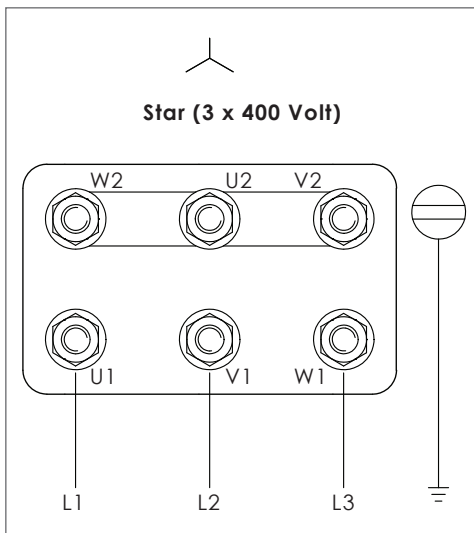
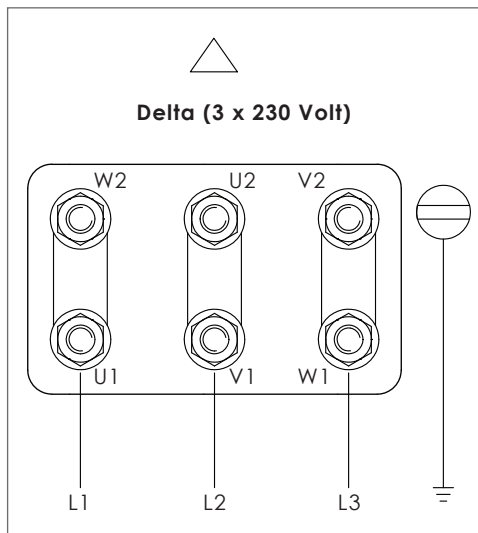

Other voltages and frequencies are available upon request.

Colours of the motor cores			
connection	colour	connection	colour
U1	blue	U2	yellow
V1	black	V2	green
W1	brown	W2	red
Power supply (L1, L2, L3)			
Option: GV-therm (purple cores)			



Installation

3-phase motor fitted with terminal box

3-phase power supply: 400/690 Volt - 50 Hz

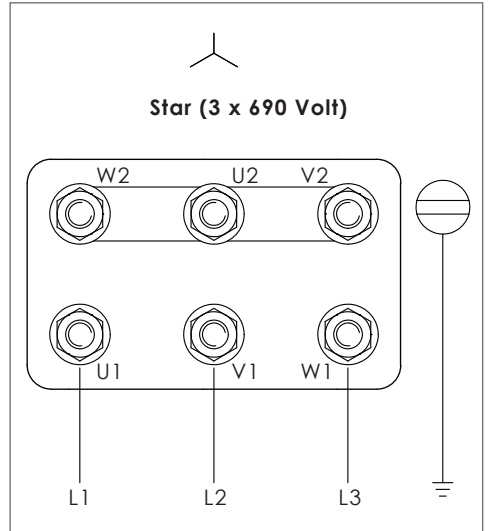
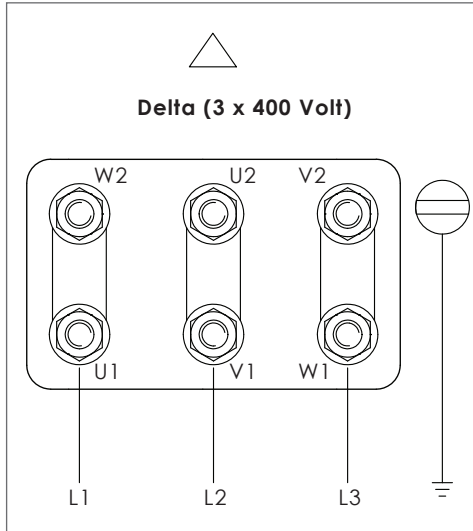

Other voltages and frequencies are available upon request.

Colours of the motor cores			
connection	colour	connection	colour
U1	blue	U2	yellow
V1	black	V2	green
W1	brown	W2	red
Power supply (L1, L2, L3)			
Option: GV-therm (purple cores)			



Installation

3-phase motor fitted with terminal box

3-phase power supply: 400 Volt - 50 Hz Dahlander

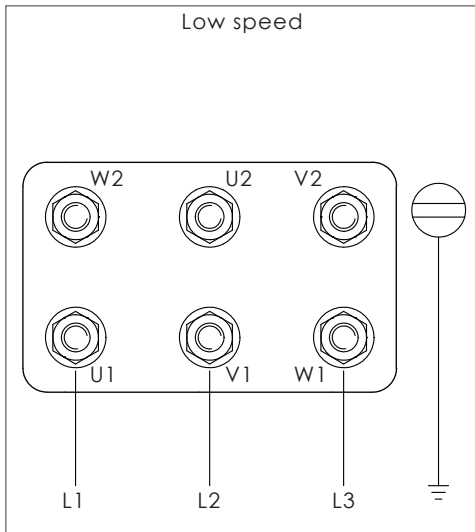
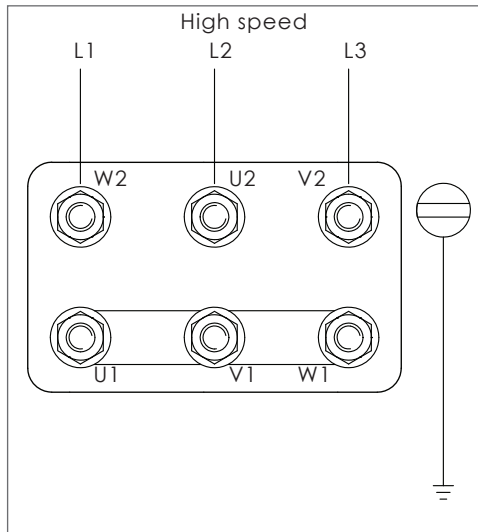

Other voltages and frequencies are available upon request.

Colours of the motor cores			
connection	colour	connection	colour
U1	blue	U2	yellow
V1	black	V2	green
W1	brown	W2	red
Power supply (L1, L2, L3)			
Option: GV-therm (purple cores)			



Installation

3-phase motor with fitted cable

4-core cable (Option: GV-therm 6 cores)

3-phase power supply: 3 x 400 Volt - 50 Hz or 3 x 230 Volt - 50 Hz

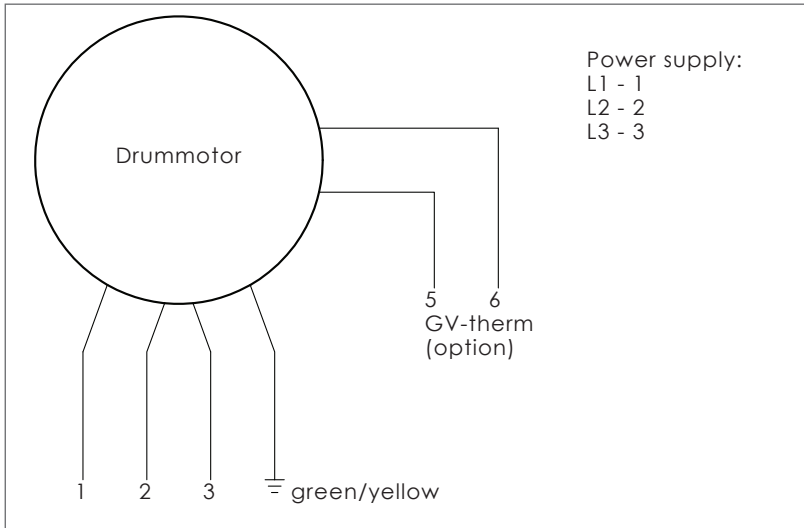

Other voltages and frequencies are available upon request.



Installation

3-phase motor fitted with cable

7-core cable (Option: GV-therm 9 cores)

3-phase power supply: star connection (high voltage), delta connection (low voltage)

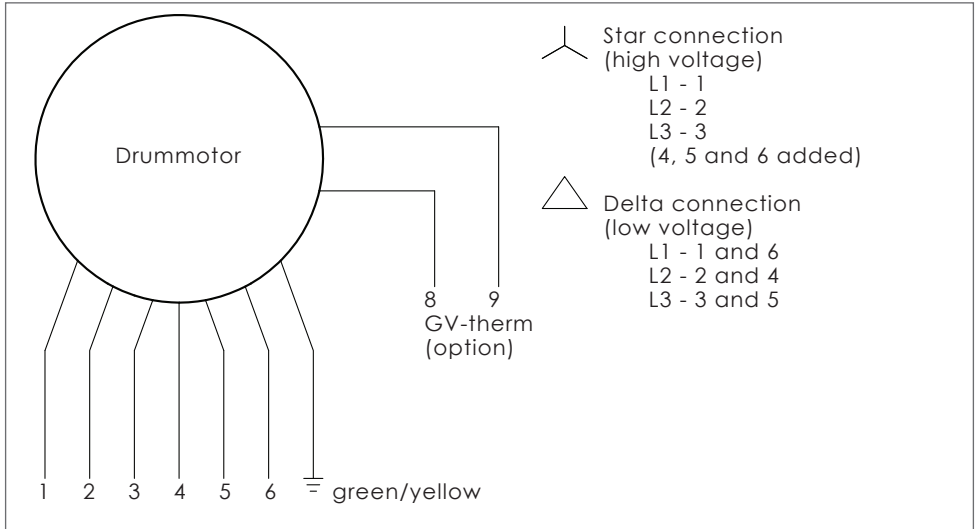

Other voltages and frequencies are available upon request.



Installation

3-phase motor with electromechanical brake, fitted with terminal box

Bridge rectifier

3-phase power supply: 3 x 400 Volt - 50 Hz

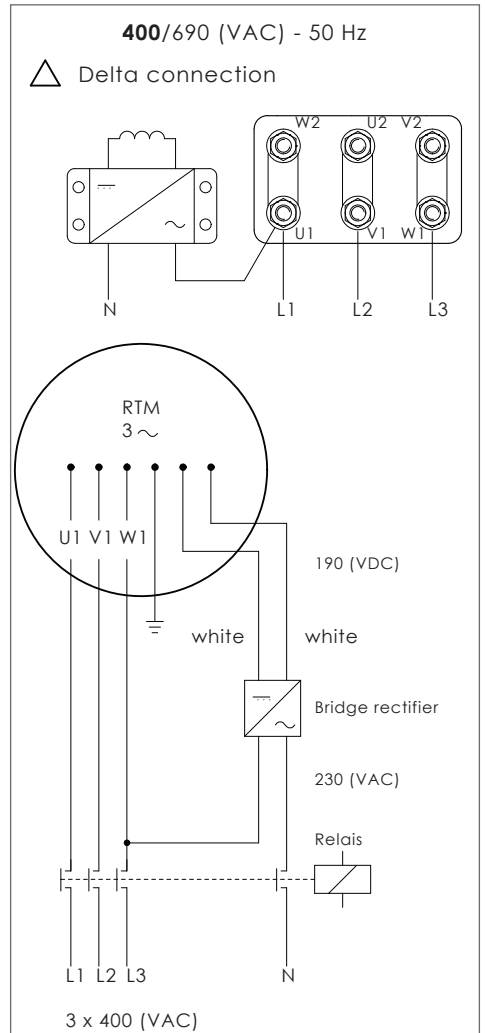
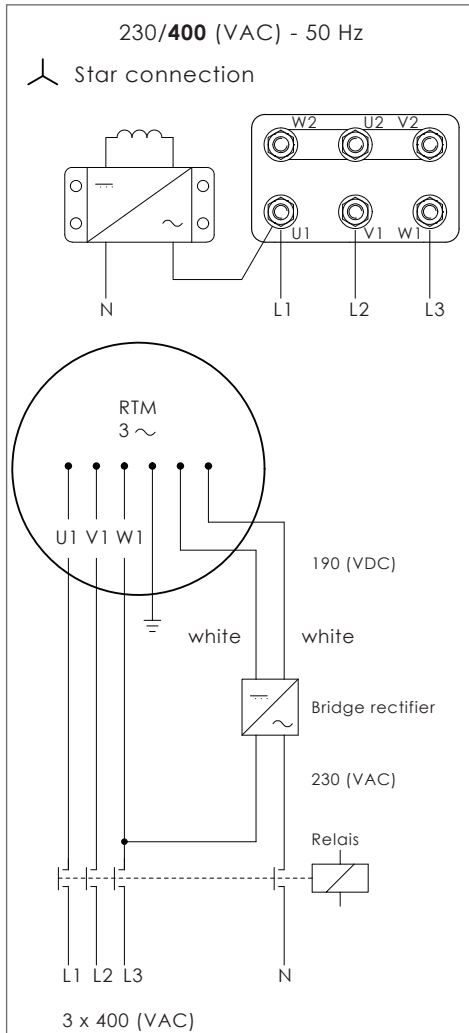

Other voltages and frequencies are available upon request.



Installation

3-phase motor with electromechanical brake, with fitted 7-core cable

Bridge rectifier

3-phase power supply: 3 x 400 Volt - 50 Hz

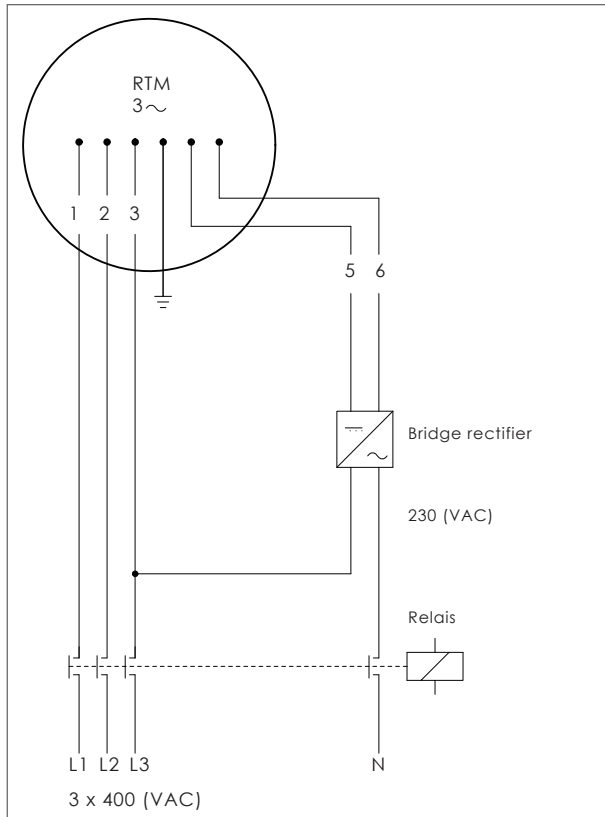

Other voltages and frequencies are available upon request.



Installation

3-phase motor with electromechanical brake, with fitted 7-core cable

One-way rectifier

3-phase power supply: 3 x 400 Volt - 50 Hz

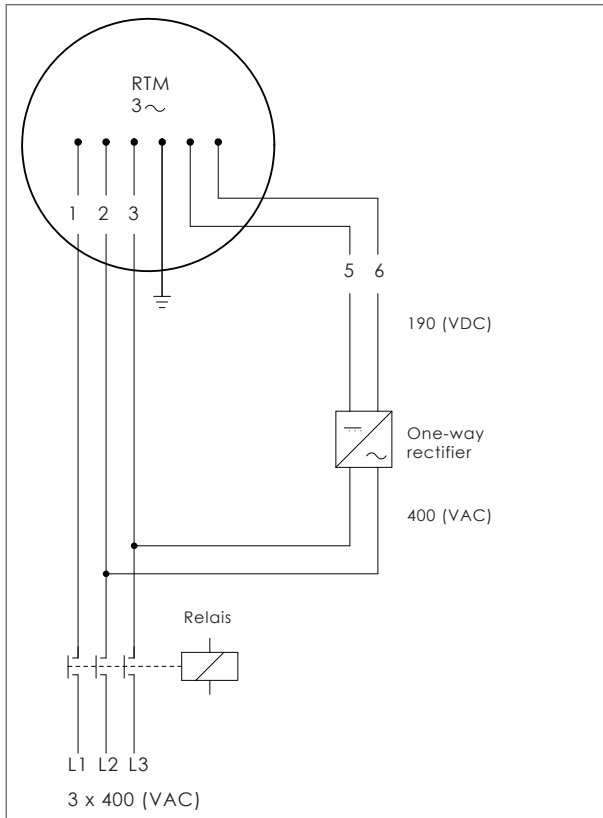

Other voltages and frequencies are available upon request.



Maintenance procedures

All Drummotors have been pre-filled with the right amount of oil at the factory. It is recommended to change this oil after 50,000 hours of service. It is advised to inspect the Drummotor on a regular base and to check for excessive noise production.

The Drummotor does not need to be removed from the conveyor frame when changing the oil providing the oil filler plug is accessible.

For recommended oil types and quantities see pages 15-21.

Remark:

Never use oil with additives which could damage the motor winding insulation and seals. It is also not permitted to use electric conducting oil types with additives, such as graphite and molybdenum disulphide, which could damage the winding. Standard oil can be used in temperatures of -20°C up to +40°C.

Changing the oil

Motor without filler plug

1. Allow the Drummotor to cool down to an acceptable and manageable temperature.
2. Loosen the top screw from the endflange at the connection side slowly to release any air pressure within the drum, this is normal.
3. Now loosen screw **a**. Rotate the Drummotor until screw **b** is at the 6 o'clock position and drain the oil.
4. Rotate the motor back to its original position.
5. Refill the Drummotor with the recommended type and quantity of oil. The oil level should be just below screw **b** (refer to Fig. 3a).
6. Renew the copper washers (Pos. 32, see pages 22-24) and replace the screws.

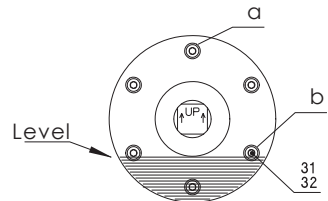

Fig. 3a

Motor with filler plug

1. Allow the Drummotor to cool down to an acceptable and manageable temperature.
2. Rotate the Drummotor until the filler plug (Pos. 34) is at the 6 o'clock position.
3. Loosen the filler plug slowly to release any air pressure within the drum (this is normal). Remove the filler plug completely and drain the oil.
4. Rotate the Drummotor until the filler plug is at the 12 o'clock position.
5. Refill the Drummotor with the recommended type and quantity of oil. The radial arrow on the drum endcap where the filler plug is located must point upwards to check for the correct oil level. With the arrow in the 12 o'clock position oil should just 'weep' out the filler plug hole (refer to Fig. 3b).
6. Replace the filler plug and renew the copper washer (Pos. 35). Refer to the construction on pages 22-24.

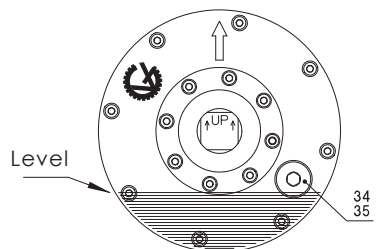

Fig. 3b



Maintenance

Recommended oil types

Manufacturer	Type
B.P.	GR-XP 100
Black Point	Bel Ray 100
Castrol	Alpha SP 100
Chevron	NL Gear Compound 100
Citgo	EP Compound 100
Divinol	ICL ISO 100
Elf	Reductelf SP 100
Esso	Spartan EP 100
Gulf Oil	EP Lubricant HD 100
Mobil Oil	Mobilgear 627
OK	TWS 100
Petro Canada	Enduratex EP 100
Shell	Omala 100
Sunoco	Sunep 100
Texaco	Meropa 100
Total	Carter EP 100

Attention:

If a Drummotor is fitted with an electromechanical brake, (indicated by RTM...WB on the data plate) the following oil type should be used: Divinol Multitrac 10W30 (Divinol), Agri-trans Plus 10 W30 (Castrol), Duratran (Petro Canada)

Recommended oil types for the food industry

Manufacturer	Type
Castrol	Optileb GT 150
Kluber	UH-1-68
Molyduval	Syntholube A 150 LM
Petro Canada	Purity FG EP 100

Attention:

If a Drummotor is fitted with an electromechanical brake, (indicated by RTM...WB on the data plate) the following oil type should be used: Divinol Syntholube A68LM (Divinol), Vitalube HS 68 (Castrol), Purity FG AW Hydraulic Fluid 46 (Petro Canada)

The referred to oil types are suitable for temperatures of -20°C up to +40°C.



Maintenance

Oil quantity

Drum length (mm)	Oil quantity (litres) per Drummotor type						
	TM 100-25	TM 113-25	TM 127-25	TM 138-25	TM 160-25	TM 160-30	TM 215-30
250			0.3	0.4			
260	0.15	0.25					
275	0.15	0.3	0.35	0.5			
300			0.4	0.55	1.25		
310	0.2	0.35					
325			0.45	0.6			
350			0.5	0.7	1.5	1.1	2.9
360	0.25	0.45					
375			0.55	0.75			
400			0.6	0.8	1.75	1.25	3.35
410	0.3	0.55					
425			0.65	0.9	1.85	1.35	3.55
450			0.75	0.95	2	1.45	3.8
460	0.35	0.65					
500			0.85	1.1	2.25	1.6	4.2
510	0.45	0.7					
550			0.95	1.2	2.5	1.8	4.65
560	0.5	0.8					
600			1.05	1.35	2.75	2	5.1
610	0.55	0.9					
650			1.15	1.5	3	2.15	5.5
660	0.6	1					
700			1.3	1.65	3.25	2.35	6
710	0.65	1.1					
750			1.4	1.75	3.5	2.5	6.4
760	0.7	1.15					
800			1.5	1.90	3.75	2.7	6.9
810	0.75	1.25					
850			1.6	2.05	4	2.9	7.3
860	0.8	1.35					
900			1.7	2.15	4.25	3.05	7.7



Maintenance

Oil quantity

TM 215-40 TM 215-50	TM 273-40	TM 315-40	TM 315-50	TM 400-50	TM 400-60	TM 500-60	TM 500-75	TM 620-75
1.9	4.7							
2.1	5.1							
2.4	5.7	10	5.6					
2.7	6.4	11	6.4					
3.05	7	12	7.1	15	12	25		
3.35	7.7	13	7.8	17	13	27		
3.7	8.3	14.5	8.5	18	14	29		
4	9	15.5	9.3	20	15	31		
4.3	9.6	16.5	10	21	16	33		
4.65	10.5	17.5	10.5	23	17	35	26	52
4.95	11	18.5	11.5	24	18	37	27	55



Maintenance

Oil quantity

Drum length (mm)	Oil quantity (litres) per Drummotor type						
	TM 100-25	TM 113-25	TM 127-25	TM 138-25	TM 160-25	TM 160-30	TM 215-30
910	0.85	1.45					
950			1.85	2.3	4.5	3.25	8.2
960	0.9	1.55					
1000			1.95	2.45	4.75	3.4	8.6
1010	1	1.6					
1050			2.05	2.55	5	3.6	9.1
1060	1.05	1.7					
1100			2.15	2.7	5.2	3.8	9.5
1110	1.1	1.8					
1150			2.25	2.85	5.5	3.95	9.9
1160	1.15	1.9					
1200			2.4	3	5.7	4.15	10.5
1250			2.5	3.1	6	4.3	11
1300			2.6	3.25	6.2	4.5	11.5
1350			2.7	3.4	6.5	4.7	11.5
1400			2.8	3.5	6.7	4.85	12
1450			2.95	3.65	7	5	12.5
1500			3.05	3.8	7.2	5.2	13
1550			3.15	3.9	7.5	5.4	13.5
1600			3.25	4.05	7.7	5.6	14
1650			3.35	4.2	8	5.8	14.5
1700			3.5	4.35	8.2	5.9	15
1750			3.6	4.45	8.5	6.1	15
1800			3.7	4.6	8.7	6.3	15.5
1850			3.8	4.75	9	6.5	16
1900			3.9	4.85	9.2	6.7	16.5
1950			4.05	5	9.5	6.8	17
2000			4.15	5.1	9.7	7	17.5

Oil quantity per 100 mm additional drum length							
	0.11	0.18	0.22	0.27	0.50	0.36	0.88



Maintenance

Oil quantity

TM 215-40 TM 215-50	TM 273-40	TM 315-40	TM 315-50	TM 400-50	TM 400-60	TM 500-60	TM 500-75	TM 620-75
5.3	11.5	19.5	12	25	19	40	29	58
5.6	12	21	13	27	21	42	31	61
5.9	13	22	13.5	28	22	44	32	64
6.2	13.5	23	14.5	30	23	46	34	68
6.6	14	24	15	31	24	48	36	71
6.9	15.0	25	16	33	25	50	37	74
7.2	15.5	26	16.5	34	26	52	39	77
7.5	16	27	17	35	27	54	41	80
7.8	17	28	18	37	28	56	42	83
8.2	17.5	29	18.5	38	29	58	44	87
8.5	18	30	19	40	30	61	46	90
8.8	18.5	31	20	41	31	63	47	93
9.1	19.5	33	21	43	32	65	49	96
9.4	20	34	22	44	33	67	51	99
9.8	21	35	22	45	34	69	52	103
10	21	36	23	47	35	71	54	106
10.5	22	37	24	48	36	73	56	109
10.5	23	38	24	50	37	75	57	112
11	23	39	25	51	39	77	59	115
11.5	24	40	26	53	40	79	60	118
11.5	25	41	27	54	41	82	62	122
12	25	42	27	55	42	84	64	125

0.64	1.3	2.1	1.4	2	2	4	3	6
------	-----	-----	-----	---	---	---	---	---



Maintenance

Oil quantity 2 pole

Drum length (mm)	Oil quantity (litres) per Drummotor type						
	TM 215-40	TM 273-40	TM 315-40	TM 315-50	TM 400-50	TM 400-60	TM 500-60
425	2.45	5.4					
450	2.6	5.8					
500	3	6.5	11	8.3			
550	3.4	7.2	12	9.3			
600	3.75	8	13.5	10.5	20	20	35
650	4.15	8.7	14.5	11.5	22	22	38
700	4.5	9.4	15.5	12.5	23	23	41
750	4.9	10	17	13	25	25	44
800	5.3	11	18	14	27	27	47
850	5.7	11.5	19	15	29	28	50
900	6	12.5	20	16	30	30	53
950	6.4	13	22	17	32	32	56
1000	6.8	14	23	18	34	34	59
1050	7.2	14.5	24	19	36	35	62
1100	7.6	15.5	25	20	38	37	65
1150	8	16	26	21	39	39	68
1200	8.3	16.5	27	22	41	40	71
1250	8.7	17.5	29	23	43	42	74
1300	9.1	18	30	24	45	44	77
1350	9.5	19	31	25	46	45	80
1400	9.9	19.5	32	26	48	47	83
1450	10	20	33	27	50	49	86



Maintenance

Oil quantity 2 pole

Drum length (mm)	Oil quantity (litres) per Drummotor type						
	TM 215-40	TM 273-40	TM 315-40	TM 315-50	TM 400-50	TM 400-60	TM 500-60
1500	10.5	21	34	28	52	51	89
1550	11	22	36	29	54	52	92
1600	11.5	23	37	30	55	54	95
1650	11.5	23	38	31	57	56	98
1700	12	24	39	32	59	57	100
1750	12.5	25	40	33	61	59	103
1800	13	25	42	34	62	61	106
1850	13.5	26	43	35	64	62	109
1900	13.5	27	44	36	66	64	112
1950	14	28	45	37	68	66	115
2000	14.5	28	46	38	70	67	118

	Oil quantity per 100 mm additional drum length						
	0.75	1.45	2.35	2	3.55	3.4	5.95



Parts

TM 113B25 PL2

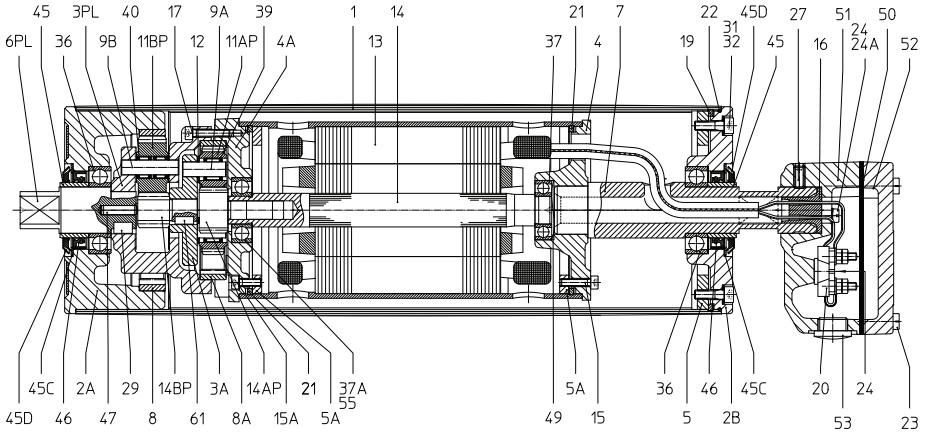

Legenda

1	Shell	14	Rotor	37	Ballbearing
2A	Endflange	14AP	Insert pinion	37A	Ballbearing
2B	Endflange	14BP	Sunwheel	39	Needlebearing
3A	Planetary housing	15	Int. hex screw	40	Needlebearing
3PL	Planetary carrier	15A	Int. hex screw	45	Bearing race
4	Motorflange	16	Cable passage	45C	Shim plated
4A	Motorflange	17	Int. hex screw	45D	Gammaring
5	Mountingring	19	Springring	46	Oilseal
5A	Mountingring	20	Terminalboard	47	Cilindrical pin
6PL	Shaftend	21	Springring	49	Wave washer
7	Hollow shaft	22	O-ring	50	Seal
8	Internal gear	23	Cyl. head screw	51	Junctionbox
8A	Internal gear	24	Cyl. head screw	52	Junctionbox cover
9A	Cylindrical pin	24A	Toothed springring	53	Blindstop
9B	Cylindrical pin	27	Setscrew	55	Ballbearing incl. backstop
11AP	Planetary gear	29	Sunk key	57	Dataplate
11BP	Planetary gear	31	Int. hex screw	61	Sunk key
12	Shim	32	Washer copper		
13	Stator	36	Ballbearing		



Parts

TM 127A25 Z

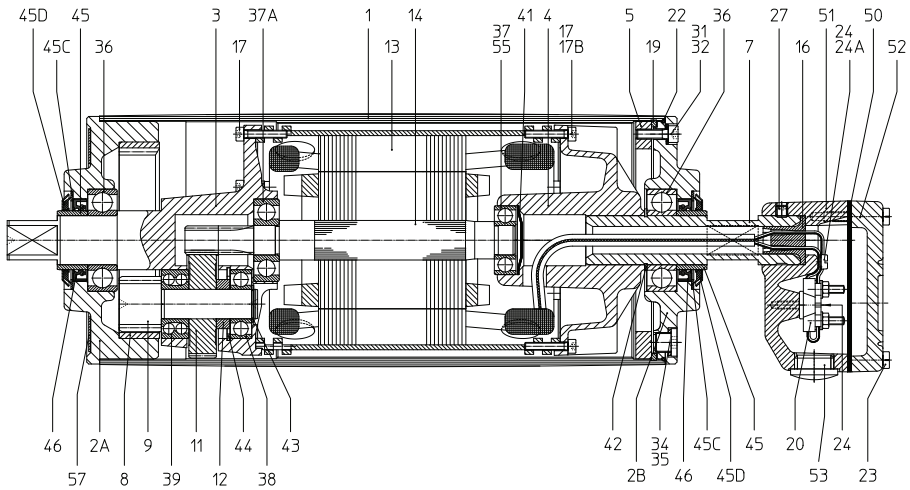

Legenda

1	Shell	20	Terminalboard	42	Circlip
2A	Endflange	22	O-ring	43	Circlip
2B	Endflange	23	Cyl. head screw	44	Circlip
3	Gearhousing	24	Cyl. head screw	45	Bearing race
4	Motorflange	24A	Toothed springring	45C	Shim plated
5	Mountingring	27	Setscrew	45D	Gammaring
7	Hollow shaft	31	Int. hex screw	46	Oilseal
8	Internal gear	32	Washer copper	50	Seal
9	Pinion	34	Fillerplug	51	Junctionbox
11	Gear	35	Washer	52	Junctionbox cover
12	Distance ring	36	Ballbearing	53	Blindstop
13	Stator	37	Ballbearing	55	Ballbearing incl. backstop
14	Rotor	37A	Ballbearing	57	Dataplate
16	Cable passage	38	Ballbearing		
17	Int. hex screw	39	Ballbearing		
19	Springing	41	Locking disc		



Parts

TM 215A40

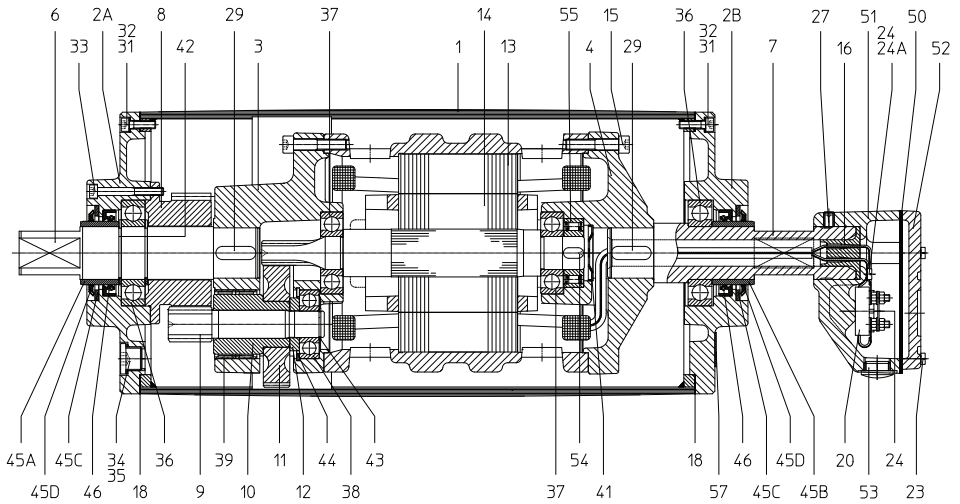

Legenda

1	Shell	20	Terminal board	42	Circlip
2A	Endflange	23	Cyl. head screw	43	Circlip
2B	Endflange	24	Cyl. head screw	44	Circlip
3	Gearhousing	24A	Toothed springring	45A	Bearing race
4	Motorflange	27	Setscrew	45B	Bearing race
6	Shaftend	29	Key	45C	Shim plated
7	Hollow shaft	31	Int. hex screw	45D	Gammaring
8	External gear	32	Washer copper	46	Oilseal
9/10	Pinion with bush	33	Int. hex screw	50	Seal
11	Gear	34	Kraagplug	51	Junctionbox
12	Distance ring	35	Fillerplug	52	Junctionbox cover
13	Stator	36	Ballbearing	53	Blindstop
14	Rotor	37	Ballbearing	54	Key
15	Int. hex screw	38	Ballbearing	55	Bearing incl. backstop
16	Cable passage	39	Needlebearing	57	Dataplate
18	Gasket	41	Disc		



Trouble-shooting

The Drummotor does not run		
	1	Check all connections.
	2	Check the power supply.
	3	If it is a three-phase Drummotor, check the voltage between all three phases. This must be equal.
The Drummotor overheats		
	1	Ensure that the ambient airtemperature does not exceed 40°C.
	2	Avoid electric overload.
	3	Check FLC with a clamp ammeter, the current consumption should not exceed the FLC value indicated on the data plate.
	4	Check the conveyor for belt slip.
The Drummotor makes a humming sound, it runs, but extremely slow or does not run at all		
	1	If it is a three-phase Drummotor, check the voltage between all three phases. This must be equal. Also check for possible interruptions in the winding.
	2	If it is a single-phase Drummotor, the start capacitor(s) is/are to be checked as well as the start switch. Check for possible interruptions in the winding.
The Drummotors overloads have „tripped“		
	1	Check for a short circuit.
	2	If a short circuit is not present, reactivate the power and check the FLC using a clamp ammeter.
The Drummotor makes a lot of noise		
	1	Is the Drummotor correctly mounted (page 4)?
	2	Check whether the indented arrow on the mounting shaft opposite the terminal box end points upwards.
	3	Check if the tension of the conveyor belt is not too high.
The Drummotor is fitted with an electromechanic brake, but does not run		
	1	Ensure correct electrical connection of the brake Drummotor.
	2	Check the supply voltage of the Drummotor and of the brake.

Remark:

If you cannot solve the problem, please contact your nearest Van der Graaf distributor.

en



Van der Graaf

Power Transmission Equipment

Contact us

Netherlands

Van der Graaf B.V.

De Weijert 14

Postbus 3

8325 ZG Vollenhove

Tel: 00 31 527 241441

Fax: 00 31 527 241488

E-mail: info@vandergraafpte.nl

www.vandergraafpte.nl

Canada

Van der Graaf Inc.

2 Van der Graaf Court

Brampton

Ontario L6T 5R6

Tel: 00 1 905 793 8100

Fax: 00 1 905 793 8129

E-mail: info@vandergraaf.com

www.vandergraaf.com

Great Britain

Van der Graaf U.K. Ltd.

Unit 23, The Metro Centre

Welbeck Way Woodston

Peterborough PE2 7UH

Tel: 00 44 1733 391777

Fax: 00 44 1733 391044

E-mail: sales@vandergraaf.co.uk

www.drummotor.com

USA

Van der Graaf Corp.

51515 Celeste

Shelby Township

48315 Michigan

Tel: 00 1 866 595 3292

Fax: 00 1 888 326 0089

Germany

Van der Graaf GmbH

Rheiner Straße 24 B

48432 Rheine-Mesum

Tel: 00 49 5975 306210

Fax: 00 49 5975 3062120

E-mail: info@vandergraaf.de

www.vandergraaf.de

Sweden

Van der Graaf Scandinavia AB

Spinngatan 2

267 73 Billesholm

Tel: 00 46 42 22 0802

Fax: 00 46 42 22 0803

E-mail: info@vandergraaf.se

www.vandergraaf.se