

SIMPLE, ACCESSIBLE AND COMPACT

INTRODUCING THE SF MELTER SERIES

SF

TOTAL ACCESSIBILITY
HIGH PERFORMANCE
EFFICIENCY
EASY TO USE
VERSATILITY

SF



EASY TO USE

A unit designed from the user's side, a unit conceived "to ease the operator's tasks. Focke Meler is committed to developing products that simplify daily work. We will continue offering simple and basic equipment which will be sharing a easy-to-use functioning system to facilitate all the operator's tasks.

Easy access to the interior's tank and electrical components in two simple steps.

- **EASE OF USE, INSTALLATION AND MAINTENANCE**
 - Easy from start to finish
- Meler's control panel
- Clean-cut design: based on users' experience
- Simplistic design: providing easy-access to all parts
- Tank lid opening angle – easy adhesive filling process

PLUG & PLAY

"Plug and play" is the concept that has guided this new design. It has all the required and most demanded characteristics for simple adhesive applications, including both bead and swirl applications.

The SF 4 model has been specifically developed to be adapted to manual applications with low adhesive consumption.

- **Fast and easy to use**
- Intuitive and simple system

SF SUPER FAST USE



PLUG & PLAY SYSTEM

TOTAL ACCESSIBILITY

Simple access to the tank's interior and electrical components.

The simplification of its design makes maintenance less time-consuming due to easier access to each and every component.

In particular, tank cleaning is much more efficient thanks to the easy access to the pump and the manifold.

PERFORMANCE AND OPTIMIZATION

The SF series offers a high-quality tank with non-stick materials, reliable pumping capacity and high energy efficiency.

Maximum power: 2 versions, 2cc/rev pump (SF4) and 8cc/rev pump (SF10 & 20) offering power and efficiency.

Its powerful simplicity allows the SF melters series to be synonymous with MAXIMUM PRODUCTIVITY.



NEW TO THE GLOBAL MARKET

Adapted to the market
Adapted to customer needs

Possibility of configuring variable speed as optional
Possibility of adding more level detectors



KEY ASPECTS

VERSATILITY AND FLEXIBILITY



3 sizes, 3 applications

The equipments can be configurable with:

- System that allows the motor to work with **variable speed**
- Level detector can be added
- Wall mounting system
- Mobility: wheel system for the base



APPLICATIONS

- Manual Applications (SF4)
- Manual and semi-automatic applications (SF10 & 20)
- Control production lines (SF10 & 20)
- Bead / Swirl adhesive applications

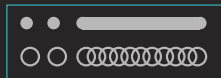

ACCESSIBLE PARTS



DIMENSIONS

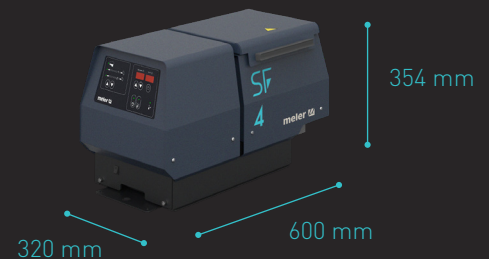
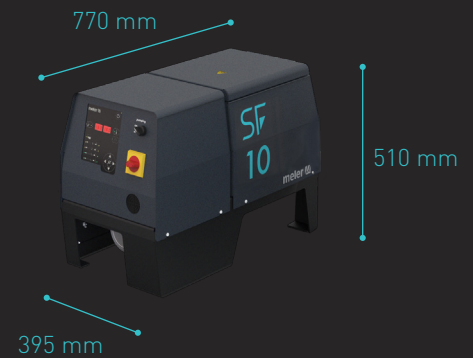

TECHNICAL FEATURES

| | |
|-------------------------------|--|
| Tank capacity | 4, 10 & 20 L |
| Melting rate (*) | Up 6kg/h (SF4) - 9 kg/h (SF 10) - 19,9kg/h (SF 20) |
| Pumps number | 1 |
| Hydraulic outputs | 2 (SF4)-4 (SF10 & 20) |
| Number of electrical outputs | 2 (SF 4) 4 (SF 10 & 20) |
| Motor power | 8cc/rev gear pump (SF10 & 20) 2cc/rev (SF4) |
| Motor speed (*) | FIXED |
| Motor with temperature sensor | YES(SF10 & 20) |
| Working temperature | 40- 200 °C (104 to 392°F) |
| Temperature control | RTD ±0,5°C (Pt100, Ni120) |
| Weight | 40 kg (SF 4) - 65 kg (SF 10) - 66,5 kg (SF 20) |
| By-pass valve | Mechanical /Pneumatic (optional) |
| Working pressure | Up to 80 bar |
| Electrical connection | 120V Single phase (SF4), 240V 2Ph (30A) or 240V 3Ph w/o neutral (SF10 & 20) |
| Options | Variable speed as optional (external box), Level detector, 240V 3-Phases w/o neutral |

(*) Under standard conditions