

# Shock Absorbers and Rate Controls



**ENIDINE**

Under the Enidine brand, we are a global leader in the design and manufacture of standard and custom energy absorption and vibration isolation product solutions. Product ranges include shock absorbers, rate controls, air springs, wire rope isolators, heavy duty buffers and emergency stops.

From Original Equipment Manufactures (OEM) to aftermarket applications, we offer a unique combination of product selection, engineering excellence and technical support to meet the toughest energy absorption requirements.



**Industry leading energy  
absorption and vibration  
isolation solutions.**

# Table of Contents

## Product Selection

<b>Company Overview</b> .....	1	General
<b>New Technologies and Enhancements</b> .....	2	
<b>Theory of Energy Absorption</b> .....	3-4	
<b>Sizing Examples</b> .....	5-14	
<b>Quick Selection Guide</b> .....	15-16	

## Shock Absorber Products



### ECO OEM/OEMXT Series (Adjustable Shock Absorbers)

Overview .....	19-20	ECO/OEM/XT
Technical Data and Accessories .....	21-34	
Adjustment Techniques .....	35	
Typical Applications .....	36	



### TK/STH Series (Non-Adjustable Shock Absorbers)

Overview .....	37-38	TK/STH
Technical Data, Accessories and Sizing Curves .....	39-43	
Typical Applications .....	44	



### ECO Series (Non-Adjustable Shock Absorbers)

Overview .....	45-46	ECO
ECO Technical Data, Accessories and Sizing Curves .....	47-55	
Typical Applications .....	56	



### PXR Series (Non-Adjustable Shock Absorbers)

Overview .....	57-58	PXR
PXR Technical Data, Accessories and Sizing Curves .....	59-62	



### PMXT Series (Non-Adjustable Shock Absorbers)

Overview .....	63-64	PMXT
Technical Data, Accessories and Sizing Curves .....	65-69	
Typical Applications .....	70	



### HDN/HD/HDA Series (Heavy Duty Shock Absorbers)

HDN Overview .....	71	HDN/HD/HDA
HDN Technical Data .....	72-76	
HDA Adjustment Techniques .....	77-78	
HD Overview .....	79	
HD Technical Data, Accessories .....	80-83	
Part Number Worksheet .....	84	



### HI Series (Heavy Industry Buffers)

Overview .....	85-86	HI
Technical Data, Accessories .....	86-87	

### Jarret Series

Overview .....	88-89	JT
Technical Data / Application Worksheet .....	90-98	
Typical Applications .....	99-100	

## Rate Control Products



### Rate Controls

Overview .....	101-102	ADA/DA
Adjustment Techniques .....	103-105	
Typical Applications .....	106	
ADA Technical Data, Accessories .....	107-109	
DA Technical Data, Accessories .....	110-112	

Application Worksheet .....	113
-----------------------------	-----



With its world headquarters located in Orchard Park, New York, USA, **ITT ENIDINE Inc.** is a world leader in the design and manufacture of standard and custom energy absorption and vibration isolation product solutions within the Industrial, Aerospace, Defense, Marine and Rail markets. Product ranges include shock absorbers, gas springs, rate controls, air springs, wire rope isolators, heavy industry buffers and emergency stops. With facilities strategically located throughout the world and in partnership with our vast global network of distributors, Enidine Incorporated continues to strengthen its presence within marketplace.

Founded in 1966, ITT Enidine Incorporated now has close to 600 employees located throughout the globe in the United States, Germany, France, Japan, China and Korea. With a team of professionals in engineering, computer science, manufacturing, production and marketing our employees provide our customers the very best in service and application solutions.

***“ITT Enidine is widely recognized as the preferred source for energy absorption and vibration isolation products.”***

From Original Equipment Manufacturers (OEM) to aftermarket applications, ITT Enidine offers a unique combination of product selection, engineering excellence and technical support to meet even the toughest energy absorption application requirements.

Global Manufacturing and Sales Facilities offer our customers:

- ***Highly Trained Distribution Network***
- ***State-of-the Art Engineering Capabilities***
- ***Custom Solution Development***
- ***Customer Service Specialists***
- ***Multiple Open Communication Channels***

If you are unsure whether one of our standard products meets your requirements, feel free to speak with one of our technical representatives **toll-free at 1-800-852-8508**, or contact us via **e-mail at [techsales@enidine.com](mailto:techsales@enidine.com)**.

### **Products/Engineering/Technical Support**

ITT Enidine continually strives to provide the widest selection of shock absorbers and rate control products in the global marketplace. Through constant evaluation and testing, we bring our customers the most cost effective products with more features, greater performance and improved ease of use.

ITT Enidine engineers continue to monitor and influence trends in the motion control industry, allowing us to remain at the forefront of new energy absorption product development such as our new ECO Series shock absorbers and our new HDN Series shock Absorbers.

Our experienced engineering team has designed custom solutions for a wide variety of challenging applications, including automated warehousing systems and shock absorbers for hostile industrial environments such as glass manufacturing, among others. These custom application solutions have proven to be critical to our customers' success. Let ITT Enidine engineers do the same for you.

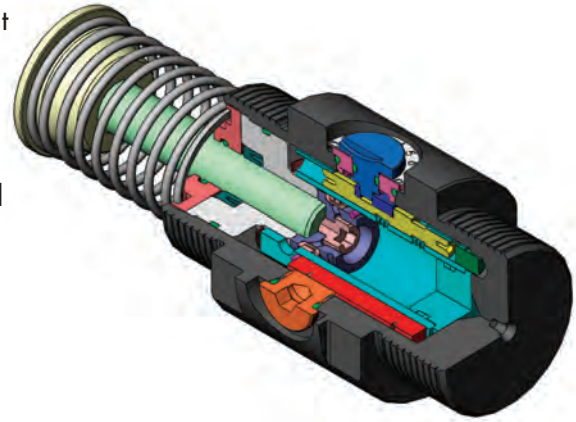

*Custom designs are not an exception at ITT Enidine, they are an integral part of our business. Should your requirements fit outside of our standard product range, Enidine engineers can assist in developing special finishes, components, hybrid technologies and new designs to ensure a "best-fit" product solution customized to your exact specifications.*

A talented engineering staff works to design and maintain the most efficient energy absorption product lines available today, using the latest engineering tools:

- **Solid Modeling**
- **3-D CAD Drawings**
- **3-D Soluable Support Technology**
- **Finite Element Analysis**
- **Complete Product Verification Testing Facility**

New product designs get to market fast because they can be fully developed in virtual environments before a prototype is ever built. This saves time and lets us optimize the best solution using real performance criteria.

## Global Service and Support

ITT Enidine offers its customers a global network of customer service staff technical sales personnel that are available to assist you with all of your application needs.

- Operating with lean manufacturing and cellular production, ITT Enidine produces higher quality custom and standard products with greater efficiency and within shorter lead times.
- An authorized Global Distribution Network is trained regularly by ITT Enidine staff on new products and services ensuring they are better able to serve you.
- **New Enisize sizing portal provides our customer with the necessary sizing and design tools. [www.enisize.com](http://www.enisize.com)**
- Global operations in United States, Germany, France, China, Japan and Korea.
- A comprehensive, website full of application information, technical data, sizing examples and information to assist in selecting the product that's right for you.

Our website also features a searchable worldwide distributor lookup to help facilitate fast, localized service. Contact us today for assistance with all of your application needs.



*Our global customer service and technical sales departments are available to assist you find the solution that's right for your application needs. Call us at 1.800.852.8508 or e-mail us at [industrialsales@enidine.com](mailto:industrialsales@enidine.com) and let us get started today.*

As companies strive to increase productivity by operating machinery at higher speeds, often the results are increased noise, damage to machinery/products, and excessive vibration. At the same time, safety and machine reliability are decreased. A variety of products are commonly used to solve these problems. However, they vary greatly in effectiveness and operation. Typical products used include rubber bumpers, springs, cylinder cushions and shock absorbers. The following illustrations compare how the most common products perform:

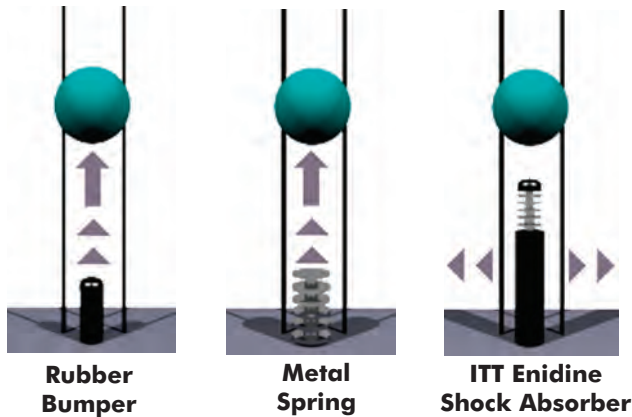

All moving objects possess kinetic energy. The amount of energy is dependent upon weight and velocity. A mechanical device that produces forces diametrically opposed to the direction of motion must be used to bring a moving object to rest.

**Rubber bumpers and springs**, although very inexpensive, have an undesirable recoil effect. Most of the energy absorbed by these at impact is actually stored. This stored energy is returned to the load, producing rebound and the potential for damage to the load or machinery. Rubber bumpers and springs initially provide low resisting force which increases with the stroke.

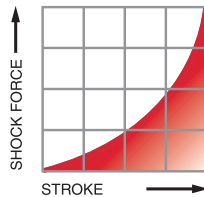

**Cylinder cushions** are limited in their range of operation. Most often they are not capable of absorbing energy generated by the system. By design, cushions have a relatively short stroke and operate at low pressures resulting in very low energy absorption. The remaining energy is transferred to the system, causing shock loading and vibration.

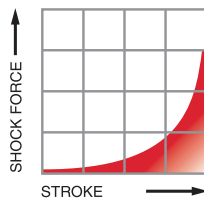

**Shock absorbers** provide controlled, predictable deceleration. These products work by converting kinetic energy to thermal energy. More specifically, motion applied to the piston of a hydraulic shock absorber pressurizes the fluid and forces it to flow through restricting orifices, causing the fluid to heat rapidly. The thermal energy is then transferred to the cylinder body and harmlessly dissipated to the atmosphere.

The advantages of using shock absorbers include:

- 1. Longer Machine Life** – The use of shock absorbers significantly reduces shock and vibration to machinery. This eliminates machinery damage, reduces downtime and maintenance costs, while increasing machine life.
- 2. Higher Operating Speeds** – Machines can be operated at higher speeds because shock absorbers control or gently stop moving objects. Therefore, production rates can be increased.
- 3. Improved Production Quality** – Harmful side effects of motion, such as noise, vibration and damaging impacts, are moderated or eliminated so the quality of production is improved. Therefore, tolerances and fits are easier to maintain.
- 4. Safer Machinery Operation** – Shock absorbers protect machinery and equipment operators by offering predictable, reliable and controlled deceleration. They can also be designed to meet specified safety standards, when required.
- 5. Competitive Advantage** – Machines become more valuable because of increased productivity, longer life, lower maintenance costs and safer operation.

## Automotive vs. Industrial Shock Absorbers

It is important to understand the differences that exist between the standard automotive-style shock absorber and the industrial shock absorber.

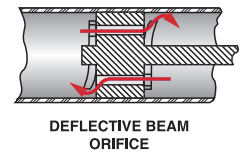

The automotive style employs the defllective beam and washer method of orificing. Industrial shock absorbers utilize single orifice, multi-orifice and metering pin configurations. The automotive type maintains a damping force which varies in direct proportion to the velocity of the piston, while the damping force in the industrial type varies in proportion to the square of the piston velocity. In addition, the damping force of the automotive type is independent of the stroke position while the damping force associated with the industrial type can be designed either dependent or independent of stroke position.

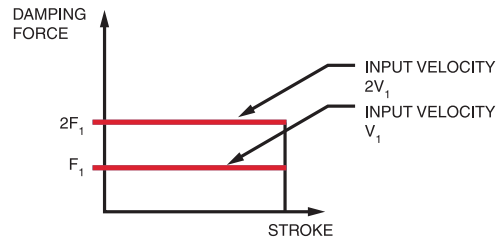

AUTOMOTIVE TYPE SHOCK ABSORBER

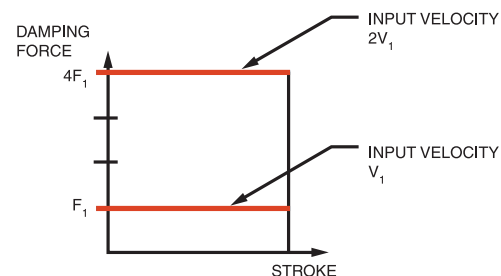

INDUSTRIAL TYPE SHOCK ABSORBER

Equally as important, automotive-style shock absorbers are designed to absorb only a specific amount of input energy. This means that, for any given geometric size of automotive shock absorber, it will have a limited amount of absorption capability compared to the industrial type.

This is explained by observing the structural design of the automotive type and the lower strength of materials commonly used. These materials can withstand the lower pressures commonly found in this type. The industrial shock absorber uses higher strength materials, enabling it to function at higher damping forces.

## Adjustment Techniques

A properly adjusted shock absorber safely dissipates energy, reducing damaging shock loads and noise levels. For optimum adjustment setting see useable adjustment setting graphs. Watching and "listening" to a shock absorber as it functions aids in proper adjustment.



To correctly adjust a shock absorber, set the adjustment knob at zero (0) prior to system engagement. Cycle the mechanism and observe deceleration of the system.

If damping appears too soft (unit strokes with no visual deceleration and bangs at end of stroke), move indicator to next largest number. Adjustments must be made in gradual increments to avoid internal damage to the unit (e.g., adjust from 0 to 1, not 0 to 4).

Increase adjustment setting until smooth deceleration or control is achieved and negligible noise is heard when the system starts either to decelerate or comes to rest.

When abrupt deceleration occurs at the beginning of the stroke (banging at impact), the adjustment setting must be moved to a lower number to allow smooth deceleration.

If the shock absorber adjustment knob is set at the high end of the adjustment scale and abrupt deceleration occurs at the end of the stroke, a larger unit may be required.

## Shock Absorber Performance When Weight or Impact Velocity Vary

When conditions change from the original calculated data or actual input, a shock absorber's performance can be greatly affected, causing failure or degradation of performance. Variations in input conditions after a shock absorber has been installed can cause internal damage, or at the very least, can result in unwanted damping performance. Variations in weight or impact velocity can be seen by examining the following energy curves:

**Varying Impact Weight:** Increasing the impact weight (impact velocity remains unchanged), without reorificing or readjustment will result in increased damping force at the end of the stroke. Figure 1 depicts this undesirable bottoming peak force. This force is then transferred to the mounting structure and impacting load.

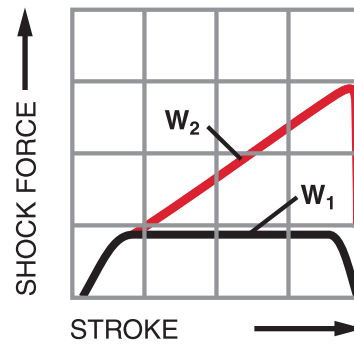

Figure 1

**Varying Impact Velocity:** Increasing impact velocity (weight remains the same) results in a radical change in the resultant shock force. Shock absorbers are velocity conscious products; therefore, the critical relationship to impact velocity must be carefully monitored. Figure 2 depicts the substantial change in shock force that occurs when the velocity is increased. Variations from original design data or errors in original data may cause damage to mounting structures and systems, or result in shock absorber failure if the shock force limits are exceeded.

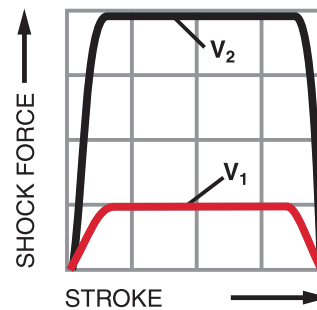
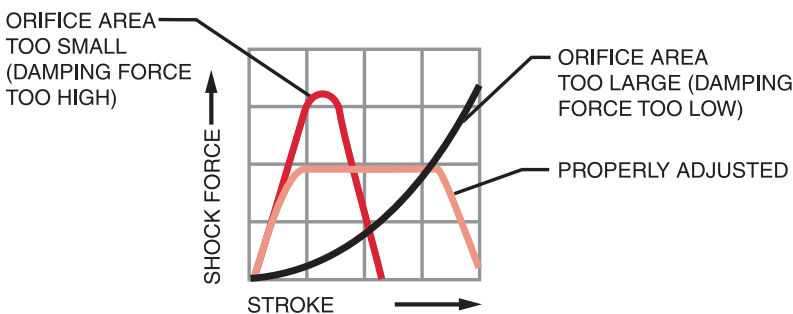

Figure 2

# Shock Absorber Sizing Examples

## Typical Shock Absorber Applications

## Overview

### SHOCK ABSORBER SIZING

Follow the next six steps to manually size Enidine shock absorbers:

**STEP 1:** Identify the following parameters. These must be known for all energy absorption calculations. Variations or additional information may be required in some cases.

- Weight of the load to be stopped (lbs.)(Kg).
- Velocity of the load upon impact with the shock absorber (in./sec.)(m/s).
- External (propelling) forces acting on the load (lbs.)(N), if any.
- Cyclic frequency at which the shock absorber will operate.
- Orientation of the application's motion (i.e. horizontal, vertical up, vertical down, inclined, rotary horizontal, rotary vertical up, rotary vertical down).

NOTE: For rotary applications, it is necessary to determine both the radius of gyration (K) and the mass moment of inertia (I). Both of these terms locate the mass of a rotating object with respect to the pivot point. It is also necessary to determine the angular velocity ( $\omega$ ) and the torque (T).

**STEP 2:** Calculate the kinetic energy of the moving object.

$$E_k = \frac{W}{772} \times V^2 \text{ (linear)} \text{ or } E_k = \frac{1}{2} \omega^2 \text{ (rotary)} \text{ or } E_k = \frac{1}{2} MV^2 \text{ (metric)}$$

(Note: 772 = 2 x acceleration due to gravity)

Utilizing the Product Locators for Shock Absorbers located at the beginning of each product family section, select a model, either adjustable or non-adjustable, with a greater energy per cycle capacity than the value just calculated.

**STEP 3:** Calculate the work energy input from any external (propelling) forces acting on the load, using the stroke of the model selected in Step 2.

$$E_w = F_D \times S \text{ (linear)} \text{ or } E_w = \frac{T}{R_S} \times S \text{ (rotary)}$$

**Caution:** The propelling force must not exceed the maximum propelling force listed for the model chosen. If the propelling force is too high, select a larger model and recalculate the work energy.

**STEP 4:** Calculate the total energy per cycle  $E_T = E_K + E_W$

The model selected must have at least this much energy capacity. If not, select a model with greater energy capacity and return to Step 3.

**STEP 5:** Calculate the energy that must be absorbed per hour. Even though the shock absorber can absorb the energy in a single impact, it may not be able to dissipate the heat generated if the cycle rate is too high.

$$E_T C = E_T \times C$$

The model selected must have an energy per hour capacity greater than this calculated figure. If it is not greater, there are two options:

- Choose another model that has more energy per hour capacity (because of larger diameter or stroke). Keep in mind that if the stroke changes, you must return to Step 3.
- Use an Air/Oil Tank. The increased surface area of the tank and piping will increase the energy per hour capacity by 20 percent.

**STEP 6:** If you have selected an HP, PM, SPM, TK, or PRO Series model, refer to the sizing graph(s) in the appropriate series section to determine the required damping constant. If the point cannot be found in the sizing graph, you must select a larger model or choose a different series. Note that if the stroke changes, you must return to Step 3.

If you have selected an adjustable model (OEM, HP or HDA series), refer to the Useable Adjustment Setting Range graph for the chosen model. The impact velocity must fall within the limits shown on the graph.

### RATE CONTROL SIZING

Follow the next five steps to manually size ITT Enidine rate controls:

**STEP 1:** Identify the following parameters. These must be known for all rate control calculations. Variations or additional information may be required in some cases.

- Weight of the load to be controlled (lbs.)(Kg)
- Desired velocity of the load (in./sec.)(m/s)
- External (propelling) force acting on the load (lbs.)(N), if any.
- Cyclic frequency at which the rate control will operate.
- Orientation of the application's motion (i.e. horizontal, vertical up, vertical down, inclined, rotary horizontal, rotary vertical up, rotary vertical down.)
- Damping direction (i.e., tension [T], compression [C] or both [T and C]).
- Required stroke (in.)(mm)

**STEP 2:** Calculate the propelling force at the rate control in each direction damping is required. (See sizing examples on page 6-12).

CAUTION: The propelling force in each direction must not exceed the maximum propelling force listed for the chosen model. If the propelling force is too high, select a larger model.

**STEP 3:** Calculate the total energy per cycle

$$E_T = E_W \text{ (tension)} + E_W \text{ (compression)} \\ E_W = F_D \times S$$

**STEP 4:** Calculate the total energy per hour

$$E_T C = E_T \times C$$

The model selected must have an energy per hour capacity greater than this calculated figure. If not, choose a model with a higher energy per hour capacity.

Compare the damping direction, stroke, propelling force, and total energy per hour to the values listed in the Rate Controls Engineering Data Charts (pages 97-106).

**STEP 5:** If you have selected a rate control, refer to the sizing graphs in the Rate Controls section to determine the required damping constant.

If you have selected an adjustable model (ADA), refer to the Useable Adjustment Setting Range graph for the chosen model. The desired velocity must fall within the limits shown on the graph.



# Shock Absorber Sizing Examples

## Typical Shock Absorber Applications

### Overview

### SYMBOLS

- a = Acceleration (in./sec.<sup>2</sup>)(m/s<sup>2</sup>)
- A = Width (in.)(m)
- B = Thickness (in.)(m)
- C = Number of cycles per hour
- d = Cylinder bore diameter (in.)(mm)
- D = Distance (in.)(m)
- E<sub>K</sub> = Kinetic energy (in-lbs.)(Nm)
- E<sub>T</sub> = Total energy per cycle (in-lbs./c)(Nm/c), E<sub>K</sub> + E<sub>W</sub>
- E<sub>T</sub>C = Total energy to be absorbed per hour (in-lbs./hr)(Nm/hr)
- E<sub>W</sub> = Work or drive energy (in-lbs.)(Nm)
- F<sub>D</sub> = Propelling force (lbs.)(N)
- F<sub>P</sub> = Shock force (lbs.)(N)
- H = Height (in.)(m)
- H<sub>p</sub> = Motor rating (hp)(kw)
- I = Mass moment of inertia (in-lbs./sec<sup>2</sup>)(Kg m<sup>2</sup>)
- K = Radius of gyration (in.)(m)
- L = Length (in.)(m)
- P = Operating pressure (psi)(bar)
- R<sub>S</sub> = Mounting distance from pivot point (in.)(m)
- S = Stroke of shock absorber (in.)(m)
- t = Time (sec.)
- T = Torque (in-lbs.)(Nm)
- V = Impact velocity (in./sec.)(m/s)
- W = Weight (lbs.)(Kg)

- α = Angle of incline (degrees)
- θ = Start point from true vertical 0° (degrees)
- μ = Coefficient of friction
- ∅ = Angle of rotation (degrees)
- ω = Angular velocity (radians/sec)

### USEFUL FORMULAS

#### 1. To Determine Shock Force

$$F_P = \frac{E_T}{S \times .85}$$

For PRO and PM Series only, use

$$F_P = \frac{E_T}{S \times .50}$$

#### 2. To Determine Impact Velocity

A. If there is no acceleration (V is constant) (e.g., load being pushed by hydraulic cylinder or motor driven.)

$$V = \frac{D}{t}$$

B. If there is acceleration. (e.g., load being pushed by air cylinder)

$$V = \frac{2 \times D}{t}$$

#### 3. To Determine Propelling Force Generated by Electric Motor

$$F_D = \frac{19,800 \times H_p}{V} \quad F_D = \frac{3,000 \times H_p}{V} \text{ (metric)}$$

#### 4. To Determine Propelling Force of Pneumatic or Hydraulic Cylinders

$$F_D = .7854 \times d^2 \times P \quad F_D = 0.07854 \times d^2 \times P \text{ (metric)}$$

#### 5. Free Fall Applications

A. Find Velocity for a Free Falling Weight:

$$V = \sqrt{772 \times H} \quad V = \sqrt{19.6 \times H} \text{ (metric)}$$

B. Kinetic Energy of Free Falling Weight:

$$E_K = W \times H$$

#### 6. Deceleration and G Load

A. To Determine Approximate G Load with a Given Stroke

$$G = \frac{F_P - F_D}{W} \quad G = \frac{F_P - F_D}{kg \times 9.81} \text{ (metric)}$$

B. To Determine the Approximate Stroke with a Given G Load (Conventional Damping Only)

$$S = \frac{E_K}{GW \times .85 - .15 F_D}$$

\*For PRO/PM and TK Models:

$$S = \frac{E_K}{GW \times .5 - .5 F_D}$$

NOTE: Constants are printed in bold.

The following examples are shown using Imperial formulas and units of measure.

### Shock Absorbers

#### EXAMPLE 1:

#### Vertical Free Falling Weight

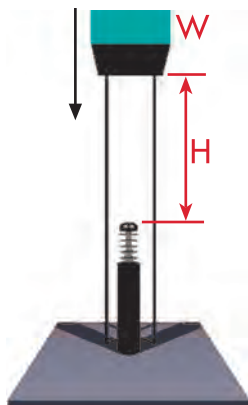

#### STEP 1: Application Data

- (W) Weight = 3,400 lbs.
- (H) Height = 20 in.
- (C) Cycles/Hr = 2

#### STEP 2: Calculate kinetic energy

$$E_K = W \times H$$

$$E_K = 3,400 \times 20 = 68,000 \text{ in-lbs.}$$

Assume Model OEM 4.0M x 6 is adequate (Page 31).

#### STEP 3: Calculate work energy

$$E_W = W \times S$$

$$E_W = 3,400 \times 6$$

$$E_W = 20,400 \text{ in-lbs.}$$

#### STEP 4: Calculate total energy per cycle

$$E_T = E_K + E_W$$

$$E_T = 68,000 + 20,400$$

$$E_T = 88,400 \text{ in-lbs./c}$$

#### STEP 5: Calculate total energy per hour

$$E_{TC} = E_T \times C$$

$$E_{TC} = 88,400 \times 2$$

$$E_{TC} = 176,800 \text{ in-lbs./hr}$$

#### STEP 6: Calculate impact velocity and confirm selection

$$V = \sqrt{772 \times H}$$

$$V = \sqrt{772 \times 20}$$

$$V = 124 \text{ in./sec.}$$

Model OEM 4.0M x 6 is adequate.

#### EXAMPLE 2:

#### Vertical Moving Load with Propelling Force Downward

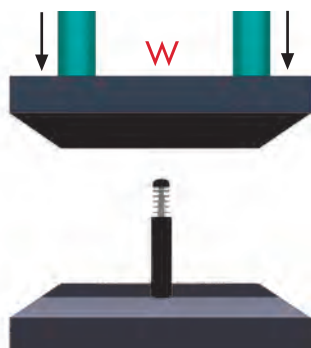

#### STEP 1: Application Data

- (W) Weight = 3,400 lbs.
- (V) Velocity = 80 in./sec.
- (d) Cylinder bore dia. = 4 in.
- (P) Pressure = 70 psi
- (C) Cycles/Hr = 200

#### STEP 2: Calculate kinetic energy

$$E_K = \frac{W}{772} \times V^2 = \frac{3,400}{772} \times 80^2$$

$$E_K = 28,187 \text{ in-lbs.}$$

Assume Model OEM 4.0M x 4 is adequate (Page 31).

#### STEP 3: Calculate work energy

$$F_D = [.7854 \times d^2 \times P] + W$$

$$F_D = [.7854 \times 4^2 \times 70] + 3,400$$

$$F_D = 4,280 \text{ lbs.}$$

$$E_W = F_D \times S$$

$$E_W = 4,280 \times 4$$

$$E_W = 17,120 \text{ in-lbs.}$$

#### STEP 4: Calculate total energy per cycle

$$E_T = E_K + E_W$$

$$E_T = 28,187 + 17,120$$

$$E_T = 45,307 \text{ in-lbs./c}$$

#### STEP 5: Calculate total energy per hour

$$E_{TC} = E_T \times C$$

$$E_{TC} = 45,307 \times 200$$

$$E_{TC} = 9,061,400 \text{ in-lbs./hr}$$

Model OEM 4.0M x 4 is adequate.

#### EXAMPLE 3: Vertical Moving Load with Propelling Force Upward

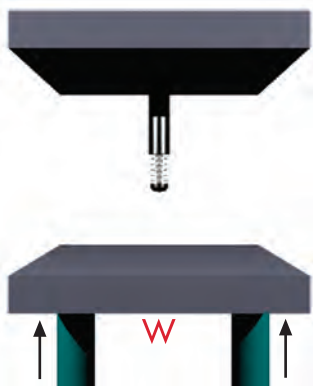

##### STEP 1: Application Data

(W) Weight = 3,400 lbs.  
(V) Velocity = 80 in./sec.  
(d) 2 Cylinders bore dia. = 6 in.  
(P) Operating pressure = 70 psi  
(C) Cycles/Hr = 200

##### STEP 2: Calculate kinetic energy

$$E_K = \frac{W}{772} \times V^2 = \frac{3,400}{772} \times 80^2$$

$$E_K = 28,187 \text{ in-lbs.}$$

Assume Model OEM 3.0M x 5 is adequate (Page 31).

##### STEP 3: Calculate work energy

$$F_D = 2 \times [.7854 \times d^2 \times P] - W$$

$$F_D = 2 \times [.7854 \times 6^2 \times 70] - 3,400$$

$$F_D = 558 \text{ lbs.}$$

$$E_W = F_D \times S$$

$$E_W = 558 \times 5$$

$$E_W = 2,790 \text{ in-lbs.}$$

##### STEP 4: Calculate total energy per cycle

$$E_T = E_K + E_W$$

$$E_T = 28,187 + 2,790$$

$$E_T = 30,977 \text{ in-lbs./c}$$

##### STEP 5: Calculate total energy per hour

$$E_{TC} = E_T \times C$$

$$E_{TC} = 30,977 \times 200$$

$$E_{TC} = 6,195,400 \text{ in-lbs./hr}$$

Model OEM 3.0M x 5 is adequate.

#### EXAMPLE 4: Vertical Moving Load with Propelling Force from Motor

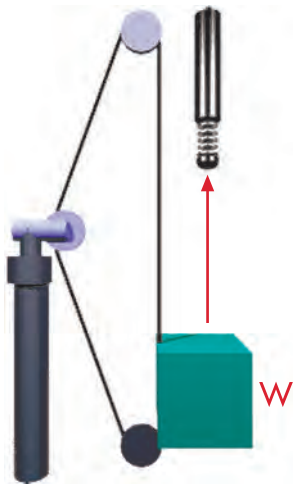

(e.g., Load Moving Force Up)

##### STEP 1: Application Data

(W) Weight = 200 lbs.  
(V) Velocity = 60 in./sec.  
(Hp) Motor horsepower = 1.5 Hp  
(C) Cycles/Hr = 100

##### STEP 2: Calculate kinetic energy

$$E_K = \frac{W}{772} \times V^2 = \frac{200}{772} \times 60^2$$

$$E_K = 933 \text{ in-lbs.}$$

##### CASE A: UP

##### STEP 3: Calculate work energy

$$F_D = \frac{19,800 \times \text{Hp} - W}{V}$$

$$F_D = \frac{19,800 \times 1.5 - 200}{60}$$

$$F_D = 295 \text{ lbs.}$$

Assume Model OEM 1.25 x 2 is adequate (Page 24).

$$E_W = F_D \times S$$

$$E_W = 295 \times 2$$

$$E_W = 590 \text{ in-lbs.}$$

##### STEP 4: Calculate total energy per cycle

$$E_T = E_K + E_W$$

$$E_T = 933 + 590$$

$$E_T = 1,523 \text{ in-lbs./c}$$

##### STEP 5: Calculate total energy per hour

$$E_{TC} = E_T \times C$$

$$E_{TC} = 1,523 \times 100$$

$$E_{TC} = 152,300 \text{ in-lbs./hr}$$

Model OEM 1.25 x 2 is adequate.

##### CASE B: DOWN

##### STEP 3: Calculate work energy

$$F_D = \frac{19,800 \times \text{Hp} + W}{V}$$

$$F_D = \frac{19,800 \times 1.5 + 200}{60}$$

$$F_D = 695 \text{ lbs.}$$

Assume Model OEMXT 2.0M x 2 is adequate (Page 29).

$$E_W = F_D \times S$$

$$E_W = 695 \times 2$$

$$E_W = 1,390 \text{ in-lbs.}$$

##### STEP 4: Calculate total energy per cycle

$$E_T = E_K + E_W$$

$$E_T = 933 + 1,390$$

$$E_T = 2,323 \text{ in-lbs./c}$$

##### STEP 5: Calculate total energy per hour

$$E_{TC} = E_T \times C$$

$$E_{TC} = 2,323 \times 100$$

$$E_{TC} = 232,300 \text{ in-lbs./hr}$$

Model OEMXT 2.0M x 2 is adequate.

#### EXAMPLE 5: Horizontal Moving Load

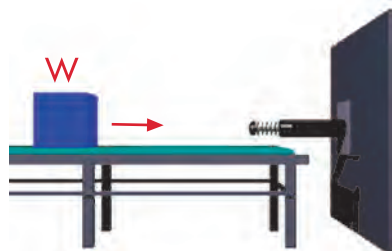

##### STEP 1: Application Data

(W) Weight = 1,950 lbs.  
(V) Velocity = 60 in./sec.  
(C) Cycles/Hr = 200

##### STEP 2: Calculate kinetic energy

$$E_K = \frac{W}{772} \times V^2$$

$$E_K = \frac{1,950}{772} \times 60^2$$

$$E_K = 9,093 \text{ in-lbs.}$$

Assume Model OEMXT 2.0M x 2 is adequate (Page 29).

##### STEP 3: Calculate work energy: N/A

##### STEP 4: Calculate total energy per cycle

$$E_T = E_K = 9,093 \text{ in-lbs./c}$$

##### STEP 5: Calculate total energy per hour

$$E_{TC} = E_T \times C$$

$$E_{TC} = 9,093 \times 200$$

$$E_{TC} = 1,818,600 \text{ in-lbs./hr}$$

Model OEMXT 2.0M x 2 is adequate.

# Shock Absorber Sizing Examples

## Typical Shock Absorber Applications

### Overview

#### EXAMPLE 6: Horizontal Moving Load with Propelling Force

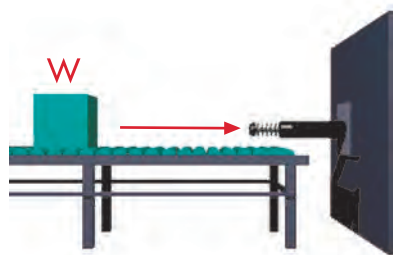

##### STEP 1: Application Data

- (W) Weight = 1,950 lbs.
- (V) Velocity = 60 in./sec.
- (d) Cylinder bore dia. = 3 in.
- (P) Operating pressure = 70 psi
- (C) Cycles/Hr = 200

##### STEP 2: Calculate kinetic energy

$$E_K = \frac{W}{772} \times V^2$$

$$E_K = \frac{1,950}{772} \times 60^2$$

$$E_K = 9,093 \text{ in-lbs.}$$

Assume Model OEMXT 2.0M x 2 is adequate (Page 29).

##### STEP 3: Calculate work energy

$$F_D = .7854 \times d^2 \times P$$

$$F_D = .7854 \times 3^2 \times 70$$

$$F_D = 495 \text{ lbs.}$$

$$E_W = F_D \times S$$

$$E_W = 495 \times 2$$

$$E_W = 990 \text{ in-lbs.}$$

##### STEP 4: Calculate total energy per cycle

$$E_T = E_K + E_W$$

$$E_T = 9,093 + 990$$

$$E_T = 10,083 \text{ in-lbs./c}$$

##### STEP 5: Calculate total energy per hour

$$E_T C = E_T \times C$$

$$E_T C = 10,083 \times 200$$

$$E_T C = 2,016,600 \text{ in-lbs./hr}$$

Model OEMXT 2.0M x 2 is adequate.

#### EXAMPLE 7: Horizontal Moving Load, Motor Driven

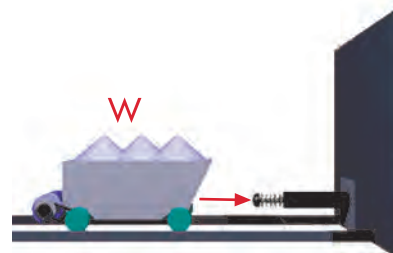

##### STEP 1: Application Data

- (W) Weight = 2,200 lbs.
- (V) Velocity = 60 in./sec.
- (Hp) Motor horsepower = 1.5 Hp
- (C) Cycles/Hr = 120

##### STEP 2: Calculate kinetic energy

$$E_K = \frac{W}{772} \times V^2$$

$$E_K = \frac{2,200}{772} \times 60^2$$

$$E_K = 10,259 \text{ in-lbs}$$

Assume Model OEMXT 2.0M x 2 is adequate (Page 29).

##### STEP 3: Calculate work energy

$$F_D = \frac{19,800 \times \text{Hp}}{V}$$

$$F_D = \frac{19,800 \times 1.5}{60}$$

$$F_D = 495 \text{ lbs.}$$

$$E_W = F_D \times S$$

$$E_W = 495 \times 2$$

$$E_W = 990 \text{ in-lbs.}$$

##### STEP 4: Calculate total energy per cycle

$$E_T = E_K + E_W$$

$$E_T = 10,259 + 990$$

$$E_T = 11,249 \text{ in-lbs./c}$$

##### STEP 5: Calculate total energy per hour

$$E_T C = E_T \times C$$

$$E_T C = 11,249 \times 120$$

$$E_T C = 1,349,880 \text{ in-lbs./hr}$$

Model OEMXT 2.0M x 2 is adequate.

#### EXAMPLE 8: Free Moving Load Down an Inclined Plane

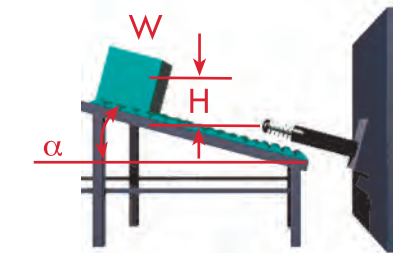

##### STEP 1: Application Data

- (W) Weight = 550 lbs.
- (H) Height = 8 in.
- (alpha) Angle of incline = 30°
- (C) Cycles/Hr = 250

##### STEP 2: Calculate kinetic energy

$$E_K = W \times H$$

$$E_K = 550 \times 8$$

$$E_K = 4,400 \text{ in-lbs.}$$

Assume Model OEMXT 1.5M x 3 is adequate (Page 27).

##### STEP 3: Calculate work energy

$$F_D = W \times \sin \alpha$$

$$F_D = 550 \times .5$$

$$F_D = 275 \text{ lbs.}$$

$$E_W = F_D \times S$$

$$E_W = 275 \times 3$$

$$E_W = 825 \text{ in-lbs.}$$

##### STEP 4: Calculate total energy per cycle

$$E_T = E_K + E_W$$

$$E_T = 4,400 + 825$$

$$E_T = 5,225 \text{ in-lbs./c}$$

##### STEP 5: Calculate total energy per hour

$$E_T C = E_T \times C$$

$$E_T C = 5,225 \times 250$$

$$E_T C = 1,306,250 \text{ in-lbs./hr}$$

##### STEP 6: Calculate impact velocity and confirm selection

$$V = \sqrt{772 \times H}$$

$$V = \sqrt{772 \times 8} = 79 \text{ in./sec.}$$

Model OEMXT 1.5M x 3 is adequate.

## Shock Absorber Sizing Examples

## Typical Shock Absorber Applications

## Overview

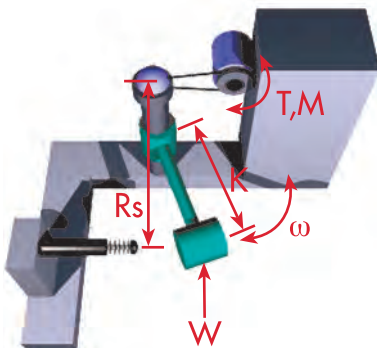
**EXAMPLE 9:**  
Horizontal Rotating Mass**STEP 1: Application Data**

(W) Weight = 200 lbs.  
 ( $\omega$ ) Angular velocity = 1.5 rad./sec.  
 (T) Torque = 1,065 in-lbs.  
 (K) Radius of gyration = 15 in.  
 ( $R_S$ ) Mounting radius = 20 in.  
 (C) Cycles/Hr = 120

**STEP 2: Calculate kinetic energy**

$$I = \frac{W}{386} \times K^2$$

$$I = \frac{200}{386} \times 15^2$$

$$I = 117 \text{ in-lbs./sec.}^2$$

$$E_K = \frac{I \times \omega^2}{2}$$

$$E_K = \frac{117 \times 1.5^2}{2}$$

$E_K = 132 \text{ in-lbs.}$   
 Assume Model STH .5M is adequate  
 (Page 40).

**STEP 3 Calculate work energy**

$$F_D = \frac{T}{R_S}$$

$$F_D = \frac{1,065}{20}$$

$$F_D = 53 \text{ lbs.}$$

$$E_W = F_D \times S$$

$$E_W = 53 \times .5$$

$$E_W = 27 \text{ in-lbs.}$$

**STEP 4: Calculate total energy per cycle**

$$E_T = E_K + E_W$$

$$E_T = 132 + 27$$

$$E_T = 159 \text{ in-lbs./c}$$

**STEP 5: Calculate total energy per hour**

$$E_{TC} = E_T \times C$$

$$E_{TC} = 159 \times 120$$

$$E_{TC} = 19,080 \text{ in-lbs./hr}$$

Model STH .5M is adequate.

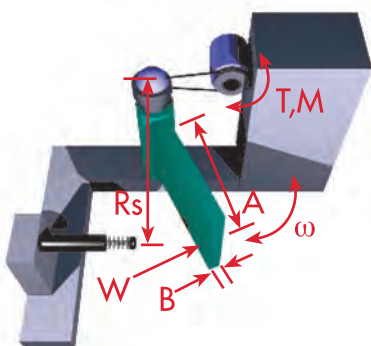
**EXAMPLE 10:**  
Horizontal Rotating Door**STEP 1: Application Data**

(W) Weight = 50 lbs.  
 ( $\omega$ ) Angular velocity = 2.5 rad./sec.  
 (T) Torque = 100 in-lbs.  
 ( $R_S$ ) Mounting radius = 20 in.  
 (A) Width = 40 in.  
 (B) Thickness = .5 in.  
 (C) Cycles/Hr = 250

**STEP 2: Calculate kinetic energy**

$$K = .289 \times \sqrt{4 \times A^2 + B^2}$$

$$K = .289 \times \sqrt{4 \times 40^2 + .5^2}$$

$$K = 23.12$$

$$I = \frac{W}{386} \times K^2$$

$$I = \frac{50}{386} \times 23.12^2$$

$$I = 69 \text{ in-lbs./sec.}^2$$

$$E_K = \frac{I \times \omega^2}{2}$$

$$E_K = \frac{69 \times 2.5^2}{2}$$

$$E_K = 216 \text{ in-lbs.}$$

Assume Model OEM .5 is adequate  
 (Page 21).

**STEP 3: Calculate work energy**

$$F_D = \frac{T}{R_S}$$

$$F_D = \frac{100}{20}$$

$$F_D = 5 \text{ lbs.}$$

$$E_W = F_D \times S = 5 \times .5 = 2.5 \text{ in-lbs.}$$

**STEP 4: Calculate total energy per cycle**

$$E_T = E_K + E_W = 216 + 2.5 = 218.5 \text{ in-lbs./c}$$

**STEP 5: Calculate total energy per hour**

$$E_{TC} = E_T \times C = 218.5 \times 250 = 54,625 \text{ in-lbs./hr}$$

**STEP 6: Calculate impact velocity and confirm selection**

$$V = R_S \times \omega = 20 \times 2.5 = 50 \text{ in./sec.}$$

Model OEM .5 is adequate.

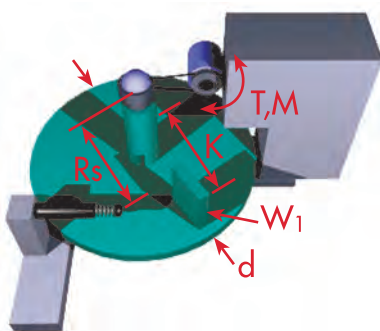
**EXAMPLE 11:**  
Horizontal Table Moving Load,  
Rotary Motor Driven with  
Additional Load Installed**STEP 1: Application Data**

(W) Weight = 440 lbs.  
 ( $W_1$ ) Installed load = 110 lbs.  
 Rotational speed = 10 RPM  
 (T) Torque = 2,200 in-lbs.  
 Rotary table dia. = 20 in.  
 ( $K_{Load}$ ) Radius of gyration = 8 in.  
 ( $R_S$ ) Mounting radius = 8.86 in.  
 (C) Cycles/Hr = 1  
 ( $\omega$ ) Direction

**Step 2: Calculate kinetic energy**

To convert RPM to rad./sec., multiply by .1047

$$\omega = \text{RPM} \times .1047 = 10 \times .1047$$

$$= 1.047 \text{ rad./sec.}$$

$$I = \frac{W}{386} \times K^2$$

In this case, the mass moment of inertia of the table and the mass moment of inertia of the load on the table must be calculated.

$$K_{Table} = \text{Table Radius} \times .707$$

$$K_{Table} = 10 \times .707 = 7.07 \text{ in.}$$

$$I_{Table} = \frac{W}{386} \times K^2_{Table}$$

$$I_{Table} = \frac{440}{386} \times 7.07^2 = 57 \text{ in-lbs./sec.}^2$$

$$I_{Load} = \frac{W_1}{386} \times K^2_{Load}$$

$$I_{Load} = \frac{110}{386} \times 8^2 = 18 \text{ in-lbs./sec.}^2$$

$$E_K = \frac{(I_{Table} + I_{Load}) \times \omega^2}{2}$$

$$E_K = \frac{(57 + 18) \times 1.047^2}{2} = 41 \text{ in-lbs.}$$

Assume Model ECO 50 is adequate  
 (Page 46).

**STEP 3: Calculate work energy**

$$F_D = \frac{T}{R_S} = \frac{2,200}{8.86} = 248 \text{ lbs.}$$

$$E_W = F_D \times S = 248 \times .875 = 217 \text{ in-lbs.}$$

**STEP 4: Calculate total energy per cycle**

$$E_T = E_K + E_W = 41 + 217 = 258 \text{ in-lbs./c}$$

**STEP 5: Calculate total energy per hour: not applicable, C = 1****STEP 6: Calculate impact velocity and confirm selection**

$$V = R_S \times \omega = 8.86 \times 1.047 = 9 \text{ in./sec.}$$

From ECO Sizing Graph.  
 Model ECO 50 is adequate.

# Shock Absorber Sizing Examples

## Typical Shock Absorber Applications

### Overview

#### EXAMPLE 12: Vertical Motor Driven Rotating Arm with Attached Load CASE A-Load Aided by Gravity

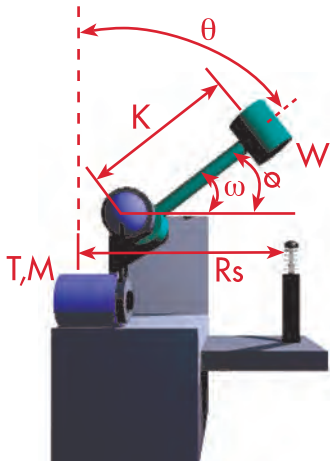

#### STEP 1: Application Data

- (W) Weight = 110 lbs.
- ( $\omega$ ) Angular velocity = 2 rad./sec.
- (T) Torque = 3,100 in-lbs.
- ( $\theta$ ) Starting point of load from true vertical = 20°
- ( $\phi$ ) Angle of rotation at impact = 30°
- (K<sub>Load</sub>) Radius of gyration = 24 in.
- (R<sub>S</sub>) Mounting radius = 16 in.
- (C) Cycles/Hr = 1

#### STEP 2: Calculate kinetic energy

$$I = \frac{W}{386} \times K^2 = \frac{110}{386} \times 24^2$$

$$I = 164 \text{ in-lbs-sec}^2$$

$$E_K = \frac{I \times \omega^2}{2}$$

$$E_K = \frac{164 \times 2^2}{2}$$

$$E_K = 328 \text{ in-lbs.}$$

Assume Model OEM 1.0 is adequate (Page 21).

#### CASE A

#### STEP 3: Calculate work energy

$$F_D = \frac{[T + (W \times K \times \sin(\theta + \phi))]}{R_S}$$

$$F_D = \frac{[3,100 + (110 \times 24 \times .77)]}{16}$$

$$F_D = 320.8 \text{ lbs.}$$

$$E_W = F_D \times S = 320.8 \times 1 = 320.8 \text{ in-lbs.}$$

#### STEP 4: Calculate total energy per cycle

$$E_T = E_K + E_W = 328 + 320.8$$

$$E_T = 648.8 \text{ in-lbs./c}$$

#### STEP 5: Calculate total energy per hour: not applicable, C = 1

#### STEP 6: Calculate impact velocity and confirm selection

$$V = R_S \times \omega = 16 \times 2 = 32 \text{ in./sec.}$$

Model LROEM 1.0 is adequate. Needed for higher calculated propelling force.

#### EXAMPLE 13: Vertical Motor Driven Rotating Arm with Attached Load CASE B-Load Opposing Gravity

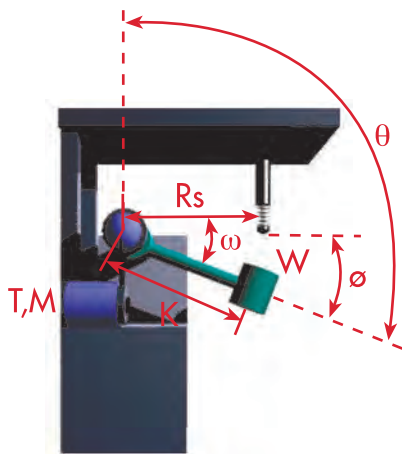

#### STEP 1: Application Data

- (W) Weight = 110 lbs.
- ( $\omega$ ) Angular velocity = 2 rad./sec.
- (T) Torque = 3,100 in-lbs.
- ( $\theta$ ) Starting point of load from true vertical = 30°
- ( $\phi$ ) Angle of rotation at impact = 150°
- (K<sub>Load</sub>) Radius of gyration = 24 in.
- (R<sub>S</sub>) Mounting radius = 16 in.
- (C) Cycles/Hr = 1

#### STEP 2: Calculate kinetic energy

$$I = \frac{W}{386} \times K^2 = \frac{110}{386} \times 24^2$$

$$I = 164 \text{ in-lbs-sec}^2$$

$$E_K = \frac{I \times \omega^2}{2}$$

$$E_K = \frac{164 \times 2^2}{2}$$

$$E_K = 328 \text{ in-lbs.}$$

Assume Model OEM 1.0 is adequate (Page 21).

#### CASE B

#### STEP 3: Calculate work energy

$$F_D = \frac{[T - (W \times K \times \sin(\theta - \phi))]}{R_S}$$

$$F_D = \frac{[3,100 - (110 \times 24 \times .77)]}{16}$$

$$E_W = F_D \times S = 67 \times 1 = 67 \text{ in-lbs.}$$

#### STEP 4: Calculate total energy per cycle

$$E_T = E_K + E_W = 328 + 67$$

$$E_T = 394.7 \text{ in-lbs./c}$$

#### STEP 5: Calculate total energy per hour: not applicable, C = 1

#### STEP 6: Calculate impact velocity and confirm selection.

$$V = R_S \times \omega = 16 \times 2 = 32 \text{ in./sec.}$$

Model OEM 1.0 is adequate.

#### EXAMPLE 14: Vertical Rotating Beam

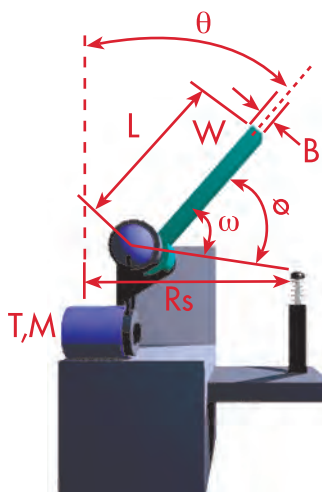

#### STEP 1: Application Data

- (W) Weight = 540 lbs.
- ( $\omega$ ) Angular velocity = 3.5 rad./sec.
- (T) Torque = 250 in-lbs.
- ( $\theta$ ) Starting point of load from true vertical = 20°
- ( $\phi$ ) Angle of rotation at impact = 50°
- (R<sub>S</sub>) Mounting radius = 20 in.
- (B) Thickness = 2.5 in.
- (L) Length = 24 in.
- (C) Cycles/Hr = 1

#### STEP 2: Calculate kinetic energy

$$K = .289 \times \sqrt{4 \times L^2 + B^2}$$

$$K = .289 \times \sqrt{4 \times 24^2 + 2.5^2} = 13.89$$

$$I = \frac{W}{386} \times K^2 = \frac{540}{386} \times 13.89$$

$$I = 270 \text{ in-lbs./sec}^2$$

$$E_K = \frac{I \times \omega^2}{2} = \frac{270 \times 3.5^2}{2} = 1,653 \text{ in-lbs.}$$

Assume Model OEM 1.5M x 2 is adequate (Page 27).

#### STEP 3: Calculate work energy

$$F_D = \frac{T + (W \times K \times \sin(\theta + \phi))}{R_S}$$

$$F_D = \frac{250 + (540 \times 13.89 \times \sin(20^\circ + 50^\circ))}{20}$$

$$F_D = 365 \text{ lbs.}$$

$$E_W = F_D \times S = 365 \times 2 = 730 \text{ in-lbs.}$$

#### STEP 4: Calculate total energy per cycle

$$E_T = E_K + E_W = 1,653 + 730 = 2,383 \text{ in-lbs./c}$$

#### STEP 5: Calculate total energy per hour: not applicable, C = 1

#### STEP 6: Calculate impact velocity and confirm selection

$$V = R_S \times \omega = 20 \times 3.5 = 70 \text{ in./sec.}$$

Model OEM 1.5M x 2 is adequate.

# Shock Absorber Sizing Examples

## Typical Shock Absorber Applications

### Overview

#### EXAMPLE 15: Vertical Rotating Lid

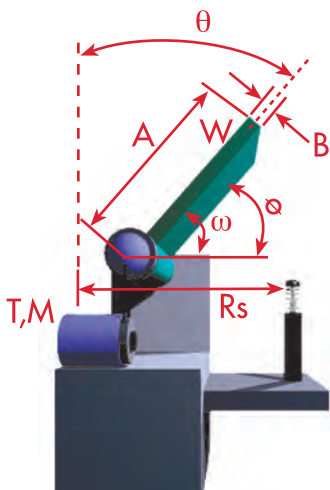

#### STEP 1: Application Data

(W) Weight = 2,000 lbs.  
 (ω) Angular velocity = 2 rad./sec.  
 (Hp) Motor horsepower = .25 Hp  
 (θ) Starting point of load from true vertical = 30°  
 (Ø) Angle of rotation at impact = 60°  
 (R<sub>S</sub>) Mounting radius = 30 in.  
 (A) Width = 60 in.  
 (B) Thickness = 1 in.  
 (C) Cycle/Hr = 1

#### STEP 2: Calculate kinetic energy

$$K = .289 \times \sqrt{4 \times A^2 + B^2}$$

$$K = .289 \times \sqrt{4 \times 60^2 + 1^2} = 34.68 \text{ in.}$$

$$I = \frac{W}{386} \times K^2 = \frac{2,000}{386} \times 34.68^2 \text{ in.}$$

$$I = 6,232 \text{ in-lbs./sec.}^2$$

$$E_K = \frac{I \times \omega^2}{2} = \frac{6,232 \times 2^2}{2}$$

$$E_K = 12,464 \text{ in-lbs.}$$

Assume Model OEM 3.0M x 2 is adequate (Page 31).

#### STEP 3: Calculate work energy

$$T = \frac{19,800 \times \text{Hp}}{\omega}$$

$$T = \frac{19,800 \times .25}{2} = 2,475 \text{ in-lbs.}$$

$$F_D = \frac{T + (W \times K \times \sin(\theta + \phi))}{R_S}$$

$$F_D = \frac{2,475 + (2,000 \times 34.68 \times \sin(30^\circ + 60^\circ))}{30}$$

$$F_D = 2,395 \text{ lbs.}$$

$$E_W = F_D \times S = 2,395 \times 2 = 4,790 \text{ in-lbs.}$$

#### STEP 4: Calculate total energy per cycle

$$E_T = E_K + E_W = 12,464 + 4,790$$

$$= 17,254 \text{ in-lbs./c}$$

#### STEP 5: Calculate total energy per hour: not applicable, C = 1

#### STEP 6: Calculate impact velocity and confirm selection

$$V = R_S \times \omega = 30 \times 2 = 60 \text{ in./sec.}$$

Model OEM 3.0M x 2 is adequate.

#### EXAMPLE 16: Vertical Rotation with Known Inertia Aided by Gravity

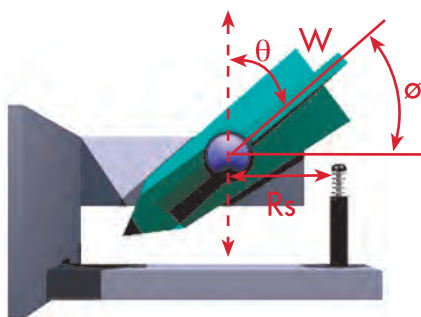

#### STEP 1: Application Data

(W) Weight = 220.5 lbs  
 (I) Known Inertia = 885 in-lbs./sec.<sup>2</sup>  
 (C/G) Center-of-Gravity = 12 in.  
 (θ) Starting point from true vertical = 60°  
 (Ø) Angle of rotation at impact = 30°  
 (R<sub>S</sub>) Mounting radius = 10 in.  
 (C) Cycles/Hr = 1

#### STEP 2: Calculate kinetic energy

$$H = C/G \times [\cos(\theta) - \cos(\phi + \theta)]$$

$$H = 12 \times [\cos(60^\circ) - \cos(30^\circ + 60^\circ)]$$

$$E_K = W \times H$$

$$E_K = 220.5 \times 6$$

$$E_K = 1,323 \text{ in-lbs.}$$

#### STEP 3: Calculate work energy

$$F_D = (W \times C/G \times \sin(\theta + \phi)) / R_S$$

$$F_D = (220.5 \times 12 \times \sin(60^\circ + 30^\circ)) / 10$$

$$F_D = 264.6 \text{ lbs.}$$

$$E_W = F_D \times S = 264.6 \times 1 = 264.6 \text{ in-lbs.}$$

#### STEP 4: Calculate total energy per cycle

$$E_T = E_K + E_W = 1,323 + 264.6$$

$$E_T = 1,587.6 \text{ in-lbs/cyc.}$$

#### STEP 5: Calculate total energy per hour: not applicable, C = 1

$$E_T C = E_T \times C$$

$$E_T C = 1,587.6 \times 1$$

$$E_T C = 1,587.6 \text{ in-lbs/hr.}$$

#### STEP 6: Calculate impact velocity and confirm selection

$$\omega = ((2 \times E_K) / I) 0.5$$

$$\omega = ((2 \times 1,323) / 885) 0.5 = 1.7$$

$$V = R_S \times \omega = 10 \times 1.7 = 17 \text{ in./sec.}$$

Model OEM 1.15 x 1 is adequate (Page 24).

#### EXAMPLE 17: Vertical Rotation with Known Inertia Aided by Gravity (w/Torque)

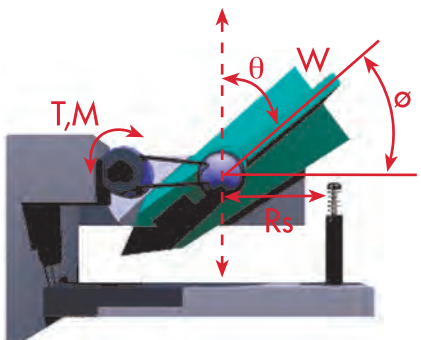

#### STEP 1: Application Data

(W) Weight = 220.5 lbs  
 (ω) Angular Velocity = 2 rad./sec.  
 (T) Torque = 2,750 in-lbs.  
 (I) Known Inertia = 885 in-lbs./sec.<sup>2</sup>  
 (C/G) Center-of-Gravity = 12 in.  
 (θ) Starting point from true vertical = 60°  
 (Ø) Angle of rotation at impact = 30°  
 (R<sub>S</sub>) Mounting radius = 10 in.  
 (C) Cycles/Hr = 100

#### STEP 2: Calculate kinetic energy

$$E_K = (I \times \omega^2) / 2$$

$$E_K = (885 \times 2^2) / 2$$

$$E_K = 1,770 \text{ in-lbs.}$$

#### STEP 3: Calculate work energy

$$F_D = [T - (W \times C/G \times \sin(\theta + \phi))] / R_S$$

$$F_D = [2,750 - (220.5 \times 12 \times \sin(60^\circ + 30^\circ))] / 10$$

$$F_D = 539.6 \text{ lbs.}$$

$$E_W = F_D \times S = 539.6 \times 1 = 539.6 \text{ in-lbs.}$$

#### STEP 4: Calculate total energy per cycle

$$E_T = E_K + E_W = 1,770 + 539.6$$

$$E_T = 2,309.6 \text{ in-lbs/cyc.}$$

#### STEP 5: Calculate total energy per hour: not applicable, C = 1

$$E_T C = E_T \times C$$

$$E_T C = 2,309.6 \times 1$$

$$E_T C = 230,960 \text{ in-lbs/hr.}$$

#### STEP 6: Calculate impact velocity and confirm selection

$$V = R_S \times \omega = 10 \times 2 = 20 \text{ in./sec.}$$

Model OEM 1.15 x 1 is adequate (Page 24).

# Shock Absorber Sizing Examples

## Typical Shock Absorber Applications

### Overview

**EXAMPLE 18:**  
Vertical Rotation with Known Inertia Aided by Gravity (w/Torque)

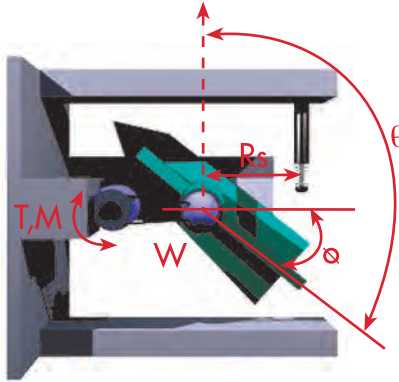

**STEP 1: Application Data**

- (W) Weight = 220.5 lbs
- ( $\omega$ ) Angular Velocity = 2 rad./sec.
- (T) Torque = 2,750 in-lbs.
- (I) Known Inertia = 885 in-lbs./sec.<sup>2</sup>
- (C/G) Center-of-Gravity = 12 in.
- ( $\theta$ ) Starting point from true vertical = 120°
- ( $\emptyset$ ) Angle of rotation at impact = 30°
- (R<sub>S</sub>) Mounting radius = 10 in.
- (C) Cycles/Hr = 100

**STEP 2: Calculate kinetic energy**

$$E_K = (I \times \omega^2) / 2$$

$$E_K = (885 \times 2^2) / 2$$

$$E_K = 1,770 \text{ in-lbs.}$$

**STEP 3: Calculate work energy**

$$F_D = [T - (W \times C/G \times \sin(\theta - \emptyset))] / R_S$$

$$F_D = [2,750 - (220.5 \times 12 \times \sin(120^\circ - 30^\circ))] / 10$$

$$F_D = 10.4 \text{ lbs.}$$

$$E_W = F_D \times S = 10.4 \times 1 = 10.4 \text{ in-lbs.}$$

**STEP 4: Calculate total energy per cycle**

$$E_T = E_K + E_W = 1,770 + 10.4$$

$$E_T = 1,780.4 \text{ in-lbs./cyc.}$$

**STEP 5: Calculate total energy per hour: not applicable, C = 1**

$$E_{TC} = E_T \times C$$

$$E_{TC} = 1,780.4 \times 100$$

$$E_{TC} = 178,040 \text{ in-lbs./hr.}$$

**STEP 6: Calculate impact velocity and confirm selection**

$$V = R_S \times \omega = 10 \times 2 = 20 \text{ in./sec.}$$

Model OEMXT 1.5M x 1 is adequate (Page 27).

**EXAMPLE 19:**  
Vertical Rotation Pinned at Center (w/Torque)

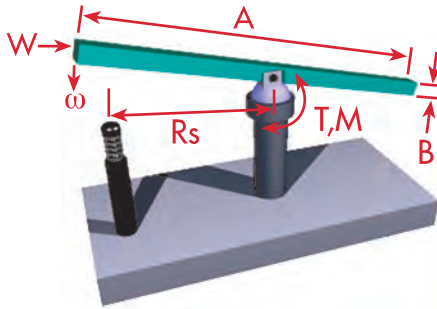

**STEP 1: Application Data**

- (W) Weight = 220.5 lbs.
- ( $\omega$ ) Angular velocity = 2 rad./sec.
- (T) Torque = 2,750 in-lbs.
- (A) Length = 40 in.
- (R<sub>S</sub>) Mounting radius = 10 in.
- (B) Thickness = 2 in.
- (C) Cycles/Hr = 100

**STEP 2: Calculate kinetic energy**

$$K = .289 \times (A^2 + B^2)^{0.5}$$

$$K = .289 \times (40^2 + 2^2)^{0.5} = 11.6 \text{ in.}$$

$$I = (W/386) \times K^2$$

$$I = (220.5/386) \times 11.6^2 = 76.9 \text{ in-lb./sec}^2$$

$$E_K = (I \times \omega^2) / 2$$

$$E_K = (76.9 \times 2^2) / 2$$

$$E_K = 153.8 \text{ in-lbs.}$$

Assume Model OEM 1.0 is adequate (Page 21).

**STEP 3: Calculate work energy**

$$F_D = T / R_S$$

$$F_D = 2,750 / 10$$

$$F_D = 275 \text{ lbs.}$$

$$E_W = F_D \times S = 275 \times 1 = 275 \text{ in-lbs.}$$

**STEP 4: Calculate total energy per cycle**

$$E_T = E_K + E_W = 153.8 + 275$$

$$E_T = 428.8 \text{ in-lbs./cycle}$$

**STEP 5: Calculate total energy per hour**

$$E_{TC} = E_T \times C$$

$$E_{TC} = 428.8 \times 100$$

$$E_{TC} = 42,880 \text{ in-lbs./hr.}$$

**STEP 6: Calculate impact velocity and confirm selection**

$$V = R_S \times \omega = 10 \times 2 = 20 \text{ in./sec.}$$

Model OEM 1.0 is adequate.

# Shock Absorber Sizing Examples

## Typical Shock Absorber and Crane Applications

### Overview

Calculations assume worst case scenario of 90% trolley weight over one rail.

Crane A		Per Buffer
Propelling Force Crane	lbs.	
Propelling Force Trolley	lbs.	
Weight of Crane ( $W_a$ )	lbs.	
Weight of Trolley ( $W_{ta}$ )	lbs.	
Crane Velocity ( $V_a$ )	in./sec.	
Trolley Velocity ( $V_{ta}$ )	in./sec.	

Crane B		Per Buffer
Propelling Force Crane	lbs.	
Propelling Force Trolley	lbs.	
Weight of Crane ( $W_b$ )	lbs.	
Weight of Trolley ( $W_{tb}$ )	lbs.	
Crane Velocity ( $V_b$ )	in./sec.	
Trolley Velocity ( $V_{tb}$ )	in./sec.	

Crane C		Per Buffer
Propelling Force Crane	lbs.	
Propelling Force Trolley	lbs.	
Weight of Crane ( $W_c$ )	lbs.	
Weight of Trolley ( $W_{tc}$ )	lbs.	
Crane Velocity ( $V_c$ )	in./sec.	
Trolley Velocity ( $V_{tc}$ )	in./sec.	

#### Please note:

Unless instructed otherwise, ITT Enidine will always calculate with:

- 100% velocity  $v$ , and
- 100% propelling force  $F_D$

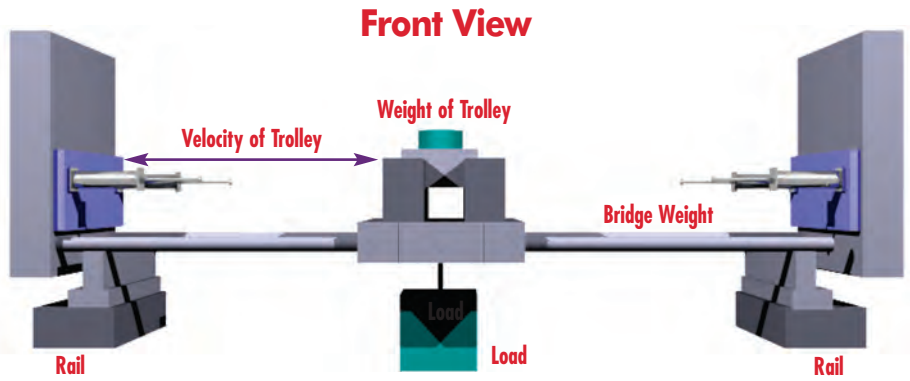

### Plan Views

#### Application 1

##### Crane A against Solid Stop

Velocity:

$$V_r = V_a$$

Impact weight per buffer:

$$W_d = \frac{W_a + (1.8) W_{ta}}{\text{Total Number of Shocks}}$$

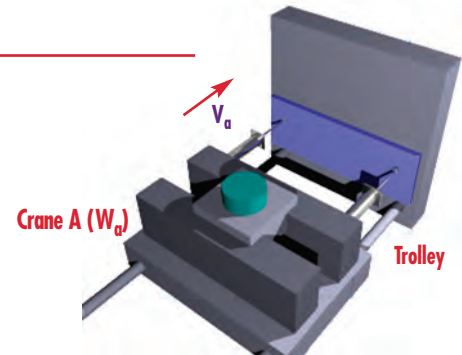

#### Application 2

##### Crane A against Crane B

Velocity:

$$V_r = V_a + V_b$$

Impact weight per buffer:

$$W_1 = W_a + (1.8) W_{ta}$$

$$W_2 = W_b + (1.8) W_{tb}$$

$$W_d = \frac{W_1 W_2}{(W_1 + W_2)(\text{Total Number of Shocks})}$$

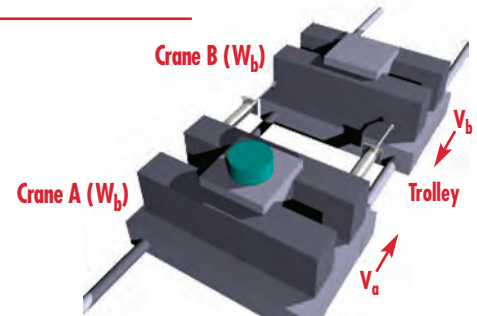

#### Application 3

##### Crane B against Crane C

Velocity:

$$V_r = \frac{V_b + V_c}{2}$$

Impact weight per buffer:

$$W_1 = W_b + (1.8) W_{tb}$$

$$W_2 = W_c + (1.8) W_{tc}$$

$$W_d = \frac{2 W_1 W_2}{(W_1 + W_2)(\text{Number of Shocks Per Rail})}$$

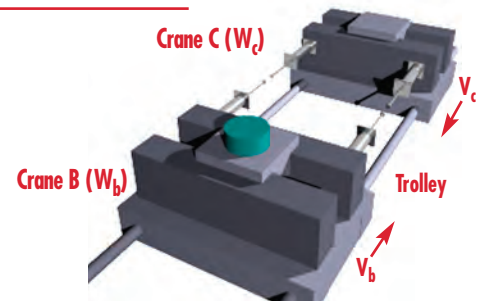

#### Application 4

##### Crane C against Solid Stop with Buffer

Velocity:

$$V_r = \frac{V_c}{2}$$

Impact weight per buffer:

$$W_1 = W_c + 1.8 (W_{tc})$$

$$W_d = \frac{2 W_1}{\text{Number of Shocks Per Rail}}$$

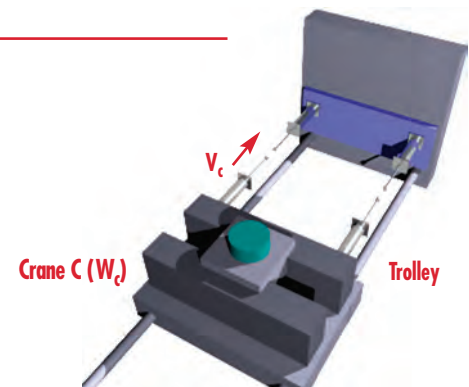



# Shock Absorber Sizing Examples

## Typical Shock Absorber and Crane Applications

### Overview

Please note that this example is not based on any particular standard. The slung load can swing freely, and is therefore not taken into account in the calculation.

### Calculation Example for Harbor Cranes as Application 1

<b>Bridge Weight:</b>	<b>837,750 lbs.</b>
<b>Weight of Trolley:</b>	<b>99,200 lbs.</b>
<b>Crane Velocity:</b>	<b>60 in./sec.</b>
<b>Required Stroke:</b>	<b>24 in.</b>
<b>Trolley Velocity:</b>	<b>160 in./sec.</b>
<b>Required Stroke:</b>	<b>40 in.</b>

### Given Values

$$W_d = \frac{W_a + (1.8) W_{ta}}{\text{Total Number of Shocks}}$$

$$W_d = \frac{837,750 + (1.8)(99,200)}{2}$$

**$W_d = 508,155 \text{ lbs.}$**

### Determination of the Maximum Impact Weight $W_d$ per Buffer

$$E_K = \frac{W_d}{772} \cdot V_r^2$$

$$E_K = \frac{508,155 \text{ lbs.}}{772} \cdot (60 \text{ in./sec.})^2$$

**$E_K = 2,369,635 \text{ in-lbs.}$**

$V_r = V_a$  (Application 1)  
 $E_K =$  Kinetic Energy  
 $\eta =$  Efficiency

Selecting for required 24-inch stroke:  
**HD 5.0 x 24, maximum shock force ca. 116,159 lbs =  $F_s = \frac{E_K}{s \cdot \eta}$**

### Determine Size of Shock Absorber for Crane

$W_t =$  Trolley Weight per Shock Absorber

$$W_t = \frac{99,200 \text{ lbs.}}{2}$$

**$W_t = 49,600 \text{ lbs.}$**

$$E_K = \frac{W_t}{772} \cdot V_t^2$$

$$E_K = \frac{49,600 \text{ lbs.}}{772} \cdot (160 \text{ in./sec.})^2$$

**$E_K = 1,644,767 \text{ in-lbs.}$**

Selecting for required 40-inch stroke:  
**HDN 4.0 x 40, maximum shock force ca. 48,376 lbs. =  $F_s = \frac{E_K}{s \cdot \eta}$**

### Determine Size of Shock Absorber for Trolley

# Shock Absorber Sizing Examples

## Typical Shock Absorber and Crane Applications

Overview

Shock Absorber Sizing Examples

Application 1	Value
Buffer Distance H	ft.
Distance X <sub>1</sub>	ft.
Distance Y <sub>1</sub>	ft.
Distance X <sub>2</sub>	ft.
Distance Y <sub>2</sub>	ft.
Total Weight	lbs.
W <sub>max d</sub>	lbs.
W <sub>min d</sub>	lbs.
W <sub>max u</sub>	lbs.
W <sub>min u</sub>	lbs.

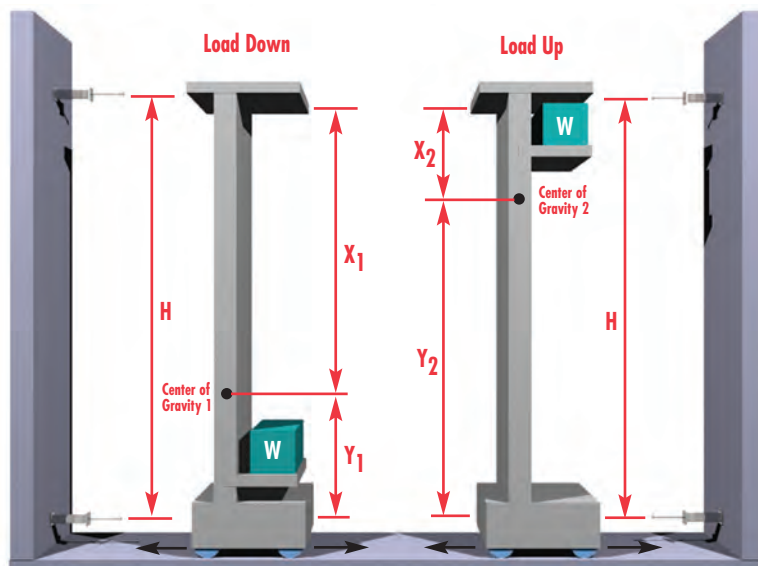

### Calculation Example Stacker Cranes

Please note that this example shows how to calculate the maximum impact weight on the upper and lower shock absorbers for a stacker crane.

Distance Between Buffers:	H = 60 ft.	<b>Given Values</b>
Distance to C of G1 - Upper:	X <sub>1</sub> = 45 ft.	
Distance to C of G1 - Lower:	Y <sub>1</sub> = 15 ft.	
Distance to C of G2 - Upper:	X <sub>2</sub> = 21 ft.	
Distance to C of G1 - Lower:	Y <sub>2</sub> = 39 ft.	
Total Weight:	W = 40,000 lbs.	
$W_{\max d} = \frac{X_1}{H} \cdot W$	$W_{\max d} = \frac{X_2}{H} \cdot W$	<b>Calculation for Lower Shock Absorbers</b>
$W_{\max d} = \frac{15 \text{ m}}{20 \text{ m}} \cdot 20 \text{ t}$	$W_{\max d} = \frac{21 \text{ ft.}}{60 \text{ ft.}} \cdot 40,000 \text{ lbs.}$	
$W_{\max d} = 15 \text{ t}$	$W_{\max d} = 14,000 \text{ lbs.}$	
$W_{\max d} = \frac{Y_1}{H} \cdot W$	$W_{\max d} = \frac{Y_2}{H} \cdot W$	<b>Calculation for Upper Shock Absorbers</b>
$W_{\max d} = \frac{5 \text{ m}}{20 \text{ m}} \cdot 20 \text{ t}$	$W_{\max d} = \frac{39 \text{ ft.}}{60 \text{ ft.}} \cdot 40,000 \text{ lbs.}$	
$W_{\max d} = 5 \text{ t}$	$W_{\max d} = 26,000 \text{ lbs.}$	
Using the value for W <sub>max</sub> obtained above, the kinetic energy can be calculated, and a shock absorber selected.		<b>Shock Absorber Selection</b>

# Shock Absorber Sizing Examples

## Typical Shock Absorber and Crane Applications

### Typical Applications

### Shock Absorber Sizing Examples



Overhead Crane Applications



Cargo Crane Applications

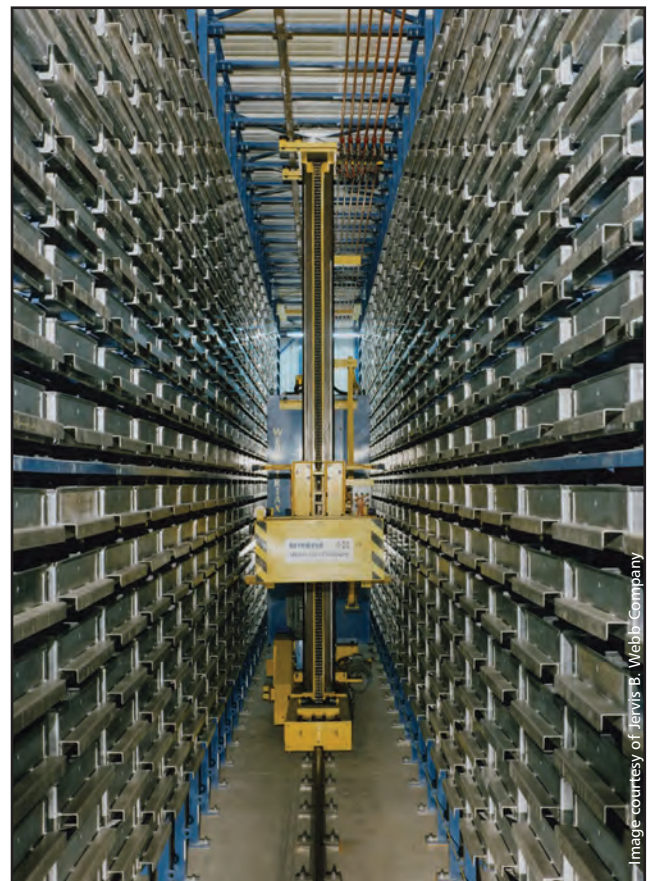

Stacker Crane Applications

Image courtesy of Jervis B. Webb Company

# Shock Absorber and Rate Controls Quick Selection Guide

## Typical Selections

## Technical Data

Use this **ITT Enidine Product Quick Selection Guide** to quickly locate potential shock absorber models most suited for your requirements. Models are organized in order of smallest to largest energy capacity per cycle within their respective product families.

### ITT Enidine Adjustable Shock Absorbers

Catalog No. (Model)	(S) Stroke (in.)	(E <sub>T</sub> ) Max. in.-lbs./cycle	(E <sub>T-C</sub> ) Max. in.-lbs./hour	Damping Type	Page No.
	1 in. = 25,4mm	1 in.-lb. = .11 Nm			
OEM 0.1M (B)	0.28	62	120,000	D	21
ECO OEM .15M (B)	0.38	62	185,000	D	21
ECO OEM .25 (B)	0.38	62	195,000	D	21
ECO LROEM .25 (B)	0.38	62	195,000	D	21
ECO OEM .35 (B)	0.50	170	331,000	D	21
ECO LROEM .35 (B)	0.50	170	331,000	D	21
ECO OEM .5 (B)	0.50	275	311,000	D	21
ECO LROEM .5 (B)	0.50	275	311,000	D	21
ECO OEM 1.0 (B)	1.00	715	681,000	C	21
ECO LROEM 1.0 (B)	1.00	715	681,000	C	21
ECO OEM 1.15 X 1	1.00	1,900	737,000	C	24
ECO LROEM 1.15 X 1	1.00	1,900	737,000	C	24
ECO OEM 1.15 X 2	2.00	3,750	963,000	C	24
ECO LROEM 1.15 X 2	2.00	3,750	963,000	C	24
ECO OEM 1.25 x 1	1.00	1,900	886,000	C	24
ECO LROEM 1.25 x 1	1.00	1,900	886,000	C	24
ECO OEM 1.25 x 2	2.00	3,750	1,084,000	C	24
ECO LROEM 1.25 x 2	2.00	3,750	1,084,000	C	24
LROEMXT 3/4 x 1	1.00	3,750	1,120,000	C	27
OEMXT 3/4 x 1	1.00	3,750	1,120,000	C	27
LROEMXT 1.5M x 1	1.00	3,750	1,120,000	C	27
OEMXT 1.5M x 1	1.00	3,750	1,120,000	C	27
LROEMXT 3/4 x 2	2.00	7,500	1,475,000	C	27
OEMXT 3/4 x 2	2.00	7,500	1,475,000	C	27
LROEMXT 1.5M x 2	2.00	7,500	1,475,000	C	27
OEMXT 1.5M x 2	2.00	7,500	1,475,000	C	27
OEMXT 3/4 x 3	3.00	11,500	1,775,000	C	27
OEMXT 1.5M x 3	3.00	11,500	1,775,000	C	27
LROEMXT 1 1/8 x 1	1.00	6,000	2,000,000	C	27
LROEMXT 1 1/8 x 2	2.00	20,000	2,400,000	C	29
OEMXT 1 1/8 x 2	2.00	20,000	2,400,000	C	29
LROEMXT 2.0M x 2	2.00	20,000	2,400,000	C	29
OEMXT 2.0M x 2	2.00	20,000	2,400,000	C	29
OEM 3.0M x 2	2.00	20,000	3,290,000	C	31
OEMXT 1 1/8 x 4	4.00	40,000	3,200,000	C	29
OEMXT 2.0M x 4	4.00	40,000	3,200,000	C	29
OEM 4.0M x 2	2.00	34,000	13,300,000	C	31
OEM 3.0M x 3.5	3.50	35,000	5,770,000	C	31
OEMXT 1 1/8 x 6	6.00	60,000	3,730,000	C	29
OEMXT 2.0M x 6	6.00	60,000	3,730,000	C	29
OEM 3.0M x 5	5.00	50,000	8,260,000	C	31
OEM 3.0M x 6.5	6.50	65,000	10,750,000	C	31
OEM 4.0M x 4	4.00	68,000	16,000,000	C	31
OEM 4.0M x 6	6.00	102,000	18,600,000	C	31
OEM 4.0M x 8	8.00	136,000	21,300,000	C	31
OEM 4.0M x 10	10.00	170,000	24,000,000	C	31

Key for Damping Type:  
D – Dashpot  
C – Conventional

P – Progressive  
SC – Self-compensating

### ITT Enidine Non-Adjustable Shock Absorbers

Catalog No. (Model)	(S) Stroke (in.)	(E <sub>T</sub> ) Max. in.-lbs./cycle	(E <sub>T-C</sub> ) Max. in.-lbs./hour	Damping Type	Page No.
	1 in. = 25,4mm	1 in.-lb. = .11 Nm			
TK 6	0.25	9	31,863	D	39
TK 8	0.25	50	42,480	D	39
TK 21	0.25	20	36,000	D	40
ECO 8	0.25	35	55,000	SC	47
TK 10M	0.25	50	115,000	D	40
ECO 10	0.28	62	120,700	SC	47
ECO 15	0.41	106	275,000	SC	47
STH .25M	0.25	100	39,000	D	41
ECO 25	0.50	265	389,000	SC	47
ECOS 50	0.50	285	440,000	SC	47
ECO 50	0.88	550	523,000	SC	47
STH .5M	0.50	585	390,000	D	41
ECO 100	1.00	930	681,500	SC	47
PRO 110	1.56	1,860	743,500	P	50
ECO 120	1.00	1,640	743,000	SC	50
ECO 125	1.00	1,640	920,500	SC	50
PMXT 1525	1.00	3,250	1,120,000	SC	59
STH .75M	0.75	2,150	780,000	D	41
ECO 220	2.00	3,100	911,600	SC	50
ECO 225	2.00	3,100	1,124,000	SC	50
PMXT 1550	2.00	6,500	1,475,000	SC	59
STH 1.0M	1.00	4,400	1,300,000	D	41
PMXT 1575	3.00	10,000	1,775,000	SC	59
STH 1.0M x 2	2.00	8,800	2,100,000	D	41
PMXT 2050	2.00	16,500	2,400,000	SC	59
STH 1.5M x 1	1.00	10,200	2,200,000	D	41
PMXT 2100	4.00	33,000	3,200,000	SC	59
STH 1.5M x 2	2.00	20,400	3,200,000	D	41
PMXT 2150	6.00	50,000	3,730,000	SC	59

Key for Damping Type:  
D – Dashpot  
C – Conventional

P – Progressive  
SC – Self-compensating

# Shock Absorber and Rate Controls Quick Selection Guide

## Typical Selections

## Technical Data

Use this **ITT Enidine Product Quick Selection Guide** to quickly locate potential shock absorber models most suited for your requirements. Models are organized in order of smallest to largest energy capacity per cycle within their respective product families.

### ITT Enidine Heavy Duty Shock Absorbers

Catalog No. (Model)	(S) Stroke (in.)	(E <sub>T</sub> ) Min./Max. in.-lbs./cycle		Damping Type	Page No.
	1 in. = 25,4mm	1 in.-lb. = .11 Nm			
HDN 1.5 x (Stroke)	2-24	27,000	185,000	C, P, SC	66
HDN 2.0 x (Stroke)	10-56	212,000	680,000	C, P, SC	67
HDN 3.0 x (Stroke)	2-56	83,000	1,200,000	C, P, SC	68
HDA 3.0 x (Stroke)	2-12	40,000	240,000	C	71
HDN 3.5 x (Stroke)	2-48	112,500	1,800,000	C, P, SC	69
HDN 4.0 x (Stroke)	2-48	134,000	2,400,000	C, P, SC	70
HDA 4.0 x (Stroke)	2-10	120,000	600,000	C	72
HD 5.0 x (Stroke)	4-40	414,000	4,150,000	C, P, SC	74
HDA 5.0 x (Stroke)	4-12	327,000	1,000,000	C	74
HD 6.0 x (Stroke)	4-48	677,000	7,125,000	C, P, SC	75
HDA 6.0 x (Stroke)	4-12	540,000	1,625,000	C	75

Key for Damping Type:  
D – Dashpot  
C – Conventional

P – Progressive  
SC – Self-compensating

### ITT Enidine Heavy Industry Shock Absorbers

Catalog No. (Model)	(S) Stroke (in.)	(E <sub>T</sub> ) Min./Max. in.-lbs./cycle		Damping Type	Page No.
	1 in. = 25,4mm	1 in.-lb. = .11 Nm			
HI 50 x (Stroke)	2-4	26,500	55,000	C, P, SC	83
HI 85 x (Stroke)	2-4	60,000	120,000	C, P, SC	83
HI 100 x (Stroke)	2-32	88,000	1,150,000	C, P, SC	83
HI 120 x (Stroke)	4-40	283,000	2,301,000	C, P, SC	83
HI 130 x (Stroke)	10-32	885,000	2,400,000	C, P, SC	84
HI 150 x (Stroke)	5-40	548,000	4,500,000	C, P, SC	84

Key for Damping Type:  
D – Dashpot  
C – Conventional

P – Progressive  
SC – Self-compensating

### Jarret Shock Absorbers

Catalog No. (Model)	(S) Stroke (in.)	(E <sub>T</sub> ) Min./Max. in.-lbs./cycle		Damping Type	Page No.
	1 in. = 25,4mm	1 in.-lb. = .11 Nm			
BC1N	0.5-3	885,000	123,910	–	87
BC5	4-7	221,000	1,327,612	–	89
XLR	6-31.5	53,000	1,327,612	–	91
LR	16-51	885,000	8,850,746	–	93

### ITT Enidine Adjustable Rate Controls

Catalog No. (Model)	(S) Stroke (in.)	(F <sub>p</sub> ) Max. Propelling Force		(E <sub>T</sub> C) Max. in.-lbs./hour	Page No.
	1 in. = 25,4mm	Tension lbs.	Compression lbs.	1 in.-lb. = .11 Nm	
ADA 505	2.00	450	450	650,000	101
ADA 510	4.00	450	375	850,000	101
ADA 515	6.00	450	300	1,050,000	101
ADA 520	8.00	450	200	1,250,000	101
ADA 525	10.00	450	125	1,450,000	101
ADA 705	2.00	2,500	2,500	1,100,000	101
ADA 710	4.00	2,500	2,500	1,400,000	102
ADA 715	6.00	2,500	2,500	1,800,000	102
ADA 720	8.00	2,500	2,500	2,100,000	102
ADA 725	10.00	2,500	2,500	2,500,000	102
ADA 730	12.00	2,500	2,500	2,800,000	102
ADA 735	14.00	2,500	2,500	3,200,000	102
ADA 740	16.00	2,500	2,500	3,500,000	103
ADA 745	18.00	2,500	2,000	3,900,000	103
ADA 750	20.00	2,500	1,700	4,200,000	103
ADA 755	22.00	2,500	1,400	4,600,000	103
ADA 760	24.00	2,500	1,200	4,900,000	103
ADA 765	26.00	2,500	1,000	5,300,000	103
ADA 770	28.00	2,500	900	5,600,000	103
ADA 775	30.00	2,500	800	6,000,000	103
ADA 780	32.00	2,500	700	6,300,000	103

### ITT Enidine Non-Adjustable Rate Controls

Catalog No. (Model)	(S) Stroke (in.)	(F <sub>p</sub> ) Max. Propelling Force		(E <sub>T</sub> C) Max. in.-lbs./hour	Page No.
	1 in. = 25,4mm	Tension lbs.	Compression lbs.	1 in.-lb. = .11 Nm	
DA 705	2.00	2,500	2,500	1,400,000	105
DA 710	4.00	2,500	2,500	1,700,000	105
DA 720	6.00	2,500	2,500	2,000,000	105
DA 720	8.00	2,500	2,500	2,300,000	105
DA 75 x 2	2.00	5,000	5,000	2,700,000	105
DA 75 x 4	4.00	5,000	5,000	3,100,000	105
DA 75 x 6	6.00	5,000	5,000	3,600,000	106
DA 75 x 8	8.00	5,000	5,000	4,100,000	106
DA 75 x 10	10.00	5,000	5,000	4,500,000	106
TB 100 x 4	4.00	10,000	10,000	4,400,000	106
TB 100 x 6	6.00	10,000	10,000	4,400,000	106



ITT Enidine Adjustable Hydraulic Series shock absorbers offer the most flexible solutions to energy absorption application requirements when input parameters vary or are not clearly defined.

ITT Enidine's **New ECO OEM Series** adjustable hydraulic shock absorbers are an expansion of our previously released ECO Series product line. These adjustable shock absorbers provide maximum flexibility in a RoHS compliant package. By simply turning an adjustment knob, the damping force can be changed to accommodate a wide range of conditions. ITT Enidine offers the broadest range of adjustable shock absorbers and mounting accessories in the marketplace today.

The ITT Enidine **OEMXT Series** provides a low profile adjustment knob offered in imperial or metric thread configurations with stroke lengths of 1 to 6 inches. For drop-in competitive interchange. **Low Range (LROEMXT) Series** products are also available to control velocities as low as 3 in./sec. and propelling forces as high as 4,000 lbs. OEMXT and OEM Large Series shock absorbers are fully field repairable.

## Features and Benefits

- **Adjustable design lets you "fine-tune"** your desired damping and lock the numbered adjustment setting.
- **Internal orifice design** provides deceleration with the most efficient damping characteristics, resulting in the lowest reaction forces in the industry.
- **Threaded cylinders provide mounting flexibility** and increase surface area for improved heat dissipation.
- **Operational parameters can be expanded** through the use of ITT Enidine's Low Range and High Performance products.
- **Custom orificed non-adjustable** units (CBOEM) can be engineered to meet specific application requirements or **emergency impact only requirements.**
- **Special materials and finishes** can be designed to meet specific customer requirements.
  - Optional fluids and seal packages can expand the standard operating temperature range from (15°F to 180°F) to (-30°F to 210°F)
  - Food grade options available
- **ISO quality standards** result in reliable, long-life operation.
- **Fully field repairable units are available** in mid-bore and larger bore product ranges.

### Added New Features for the ECO OEM Series

- **Environmentally friendly materials:**
  - ROHS Compliant materials
  - Bio-degradable hydraulic oil
  - Copper-Free design
  - Recyclable packaging materials
- **Introducing our new Enicote II surface finish:**
  - ROHS Compliant
  - Rated at 350 hours salt spray corrosion protection
- **Jam Nut included** with every shock absorber.
- **Wrench flats** promote ease of mounting
- **Capability to mount into pressure chambers**
- **Integrated positive stopping capabilities** up to 100 psi (7 bar).

# Adjustable Series Hydraulic Shock Absorbers

## ECO OEM and OEMXT Series

### Overview

### ITT Enidine Adjustable Single Orifice Shock Absorbers

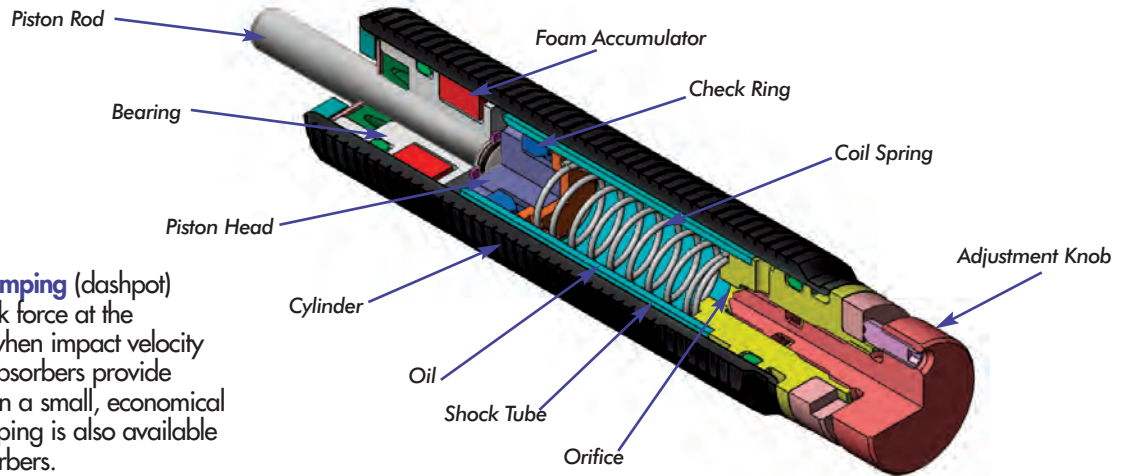
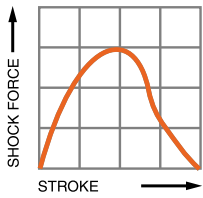

**Constant orifice area damping** (dashpot) provides the largest shock force at the beginning of the stroke when impact velocity is highest. These shock absorbers provide high-energy absorption in a small, economical design. This type of damping is also available in adjustable shock absorbers.

The damping force of an ITT Enidine single orifice shock absorber can be changed by turning the adjustment knob. Maximum damping force is achieved by turning the adjustment knob to eight (8), while minimum damping force is achieved by turning the adjustment knob to zero (0). Turning the adjustment knob causes the adjustment ball to increase or decrease the clearance (orifice area) between the ball and its seat, depending on rotation direction.

The internal structure of an adjustable single orifice shock absorber is shown above. When force is applied to the piston rod, the check ball is seated and the valve remains closed.

Oil is forced out of the high pressure shock tube chamber through the orifice, creating internal pressure allowing smooth, controlled deceleration of the moving load. When the load is removed, the compressed coil spring moves to reposition the piston head, the check ball unseats, opening the valve that permits rapid piston rod return to the original extended position. The closed cellular foam accumulator compensates for fluid displaced by the piston rod during compression and extension. Without the fluid displacement volume provided by the foam accumulator, the closed system would be hydraulically locked. This type of orifice design produces constant orifice area damping.

### ITT Enidine Adjustable Multiple Orifice Shock Absorbers

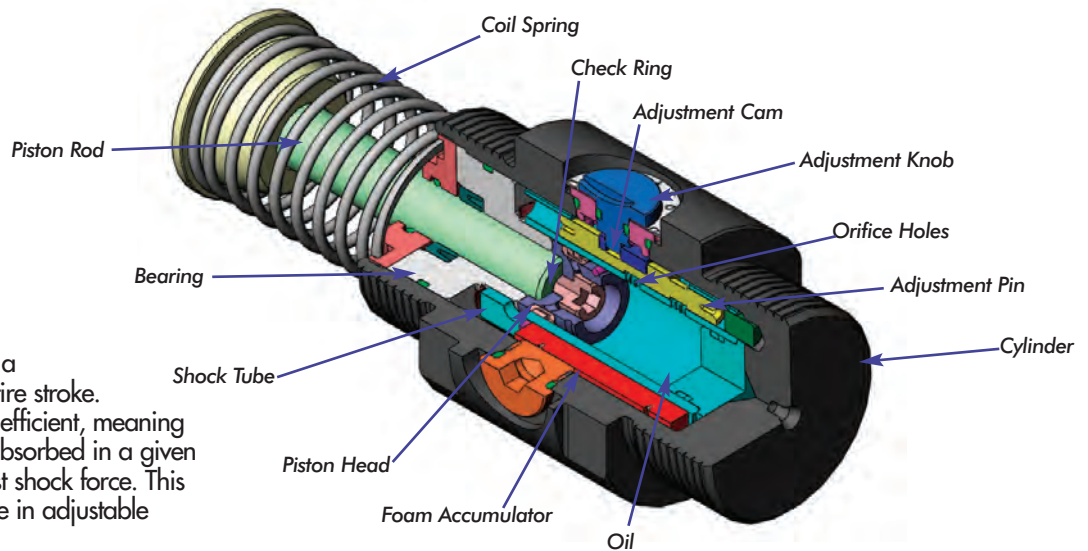
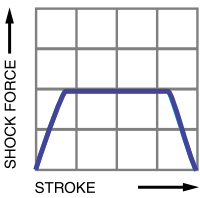

**Conventional damping** allows linear deceleration by providing a constant shock force over the entire stroke. This standard design is the most efficient, meaning it allows the most energy to be absorbed in a given stroke, while providing the lowest shock force. This type of damping is also available in adjustable shock absorbers.

The adjustable multiple orifice shock absorber is similar to the principles described earlier. The check ring replaces the check ball and the adjustment feature uses an adjustment pin instead of an adjustment ball. The damping force of the shock absorber can be changed by turning the adjustment knob. Maximum damping force is achieved by turning the adjustment knob to eight (8), while minimum damping force is achieved by turning the adjustment knob to zero (0).

Turning the adjustment knob rotates the adjustment cam within the shock absorber. The cam, in turn, moves the adjustment pin in the shock tube, closing or opening the orifice holes. By closing the orifice holes, the total orifice area of the shock absorber is reduced, thus increasing the damping force of the shock absorber. The adjustable shock absorber enables the user to change the damping force of the unit, should input conditions change, while still maintaining a conventional-type damping curve. Low velocity range (LR) series configurations are available for controlling velocities that fall below the standard adjustable range.

OEM 0.1M → (LR)OEM 1.0 Series

**Standard**

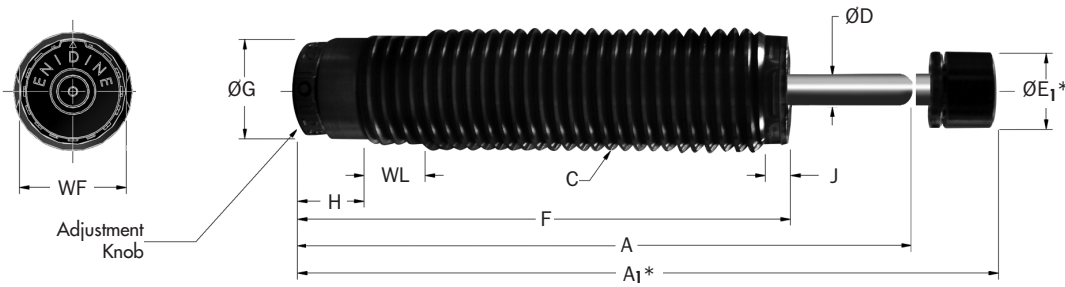

\*Note: A<sub>1</sub> and E<sub>1</sub> apply to button models. One Hex Jam Nut included with every shock absorber (Except OEM .1M (B)).

Catalog No./Model	(S) Stroke in. (mm)	Optimal Velocity Range in./sec. (m/s)	(E <sub>T</sub> ) Max. in.-lbs./cycle (Nm/cycle)	(E <sub>T</sub> C) Max. in.-lbs./hour (Nm/h)	(F <sub>p</sub> ) Max. Reaction Force lbs. (N)	Nominal Coil Spring Force		(F <sub>D</sub> ) Max. Propelling Force lbs. (N)	Model Weight (mass) oz (g)
						Extended lbs. (N)	Compressed lbs. (N)		
OEM .1M (B)	0.28 (7,0)	12-130 (0,3-3,30)	62 (7,0)	120,000 (13 600)	275 (1 220)	0.5 (2,2)	1.0 (4,5)	80 (350)	1 (28)
ECO OEM .15M (B)	0.38 (10,0)	12-130 (0,3-3,30)	62 (7,0)	185,000 (20 900)	200 (890)	0.8 (3,5)	1.7 (7,5)	80 (350)	2 (56)
ECO OEM .25 (B)	0.38 (10,0)	12-130 (0,3-3,30)	62 (7,0)	195,000 (22 000)	200 (890)	0.8 (3,5)	1.7 (7,5)	80 (350)	2 (56)
ECO LROEM .25 (B)	0.38 (10,0)	3-50 (0,08-1,30)	62 (7,0)	195,000 (22 000)	200 (890)	0.8 (3,5)	1.7 (7,5)	100 (440)	2 (56)
ECO LROEM .25M (B)	0.38 (10,0)	3-50 (0,08-1,30)	62 (7,0)	195,000 (22 000)	200 (890)	0.8 (3,5)	1.7 (7,5)	100 (440)	2 (56)
ECO OEM .35 (B)	0.50 (12,7)	12-130 (0,3-3,30)	120 (19,0)	331,000 (37 400)	450 (2 000)	1.0 (4,5)	2.2 (9,8)	120 (530)	3 (85)
ECO OEM .35M (B)	0.50 (12,7)	12-130 (0,3-3,30)	120 (19,0)	331,000 (37 400)	450 (2 000)	1.0 (4,5)	2.2 (9,8)	120 (530)	3 (85)
ECO LROEM .35 (B)	0.50 (12,7)	3-50 (0,08-1,30)	120 (19,0)	331,000 (37 400)	450 (2 000)	1.0 (4,5)	2.2 (9,8)	200 (890)	3 (85)
ECO LROEM .35M (B)	0.50 (12,7)	3-50 (0,08-1,30)	120 (19,0)	331,000 (37 400)	450 (2 000)	1.0 (4,5)	2.2 (9,8)	200 (890)	3 (85)
ECO OEM .5 (B)	0.50 (12,7)	12-180 (0,3-4,50)	275 (31,0)	311,000 (35 200)	775 (3 500)	1.3 (5,8)	2.8 (12,4)	150 (670)	5 (141)
ECO OEM .5M (B)	0.50 (12,7)	12-180 (0,3-4,50)	275 (31,0)	311,000 (35 200)	775 (3 500)	1.3 (5,8)	2.8 (12,4)	150 (670)	5 (141)
ECO LROEM .5 (B)	0.50 (12,7)	3-50 (0,08-1,30)	275 (31,0)	311,000 (35 200)	775 (3 500)	2.0 (8,9)	3.8 (17,0)	250 (1 120)	5 (141)
ECO LROEM .5M (B)	0.50 (12,7)	3-50 (0,08-1,30)	275 (31,0)	311,000 (35 200)	775 (3 500)	2.0 (8,9)	3.8 (17,0)	250 (1 120)	5 (141)
ECO OEM 1.0 (B)	1.00 (25,0)	12-130 (0,3-3,30)	715 (81,0)	681,000 (77 000)	1,000 (4 400)	3.0 (13,0)	6.0 (26,0)	300 (1 330)	10 (285)
ECO OEM 1.0M (B)	1.00 (25,0)	12-130 (0,3-3,30)	715 (81,0)	681,000 (77 000)	1,000 (4 400)	3.0 (13,0)	6.0 (26,0)	300 (1 330)	10 (285)
ECO LROEM 1.0 (B)	1.00 (25,0)	3-50 (0,08-1,30)	715 (81,0)	681,000 (77 000)	1,000 (4 400)	3.0 (13,0)	6.0 (27,0)	450 (2 016)	10 (285)
ECO LROEM 1.0M (B)	1.00 (25,0)	3-50 (0,08-1,30)	715 (81,0)	681,000 (77 000)	1,000 (4 400)	3.0 (13,0)	6.0 (27,0)	450 (2 016)	10 (285)

Catalog No./Model	A in. (mm)	A <sub>1</sub> in. (mm)	C in. (mm)	D in. (mm)	E <sub>1</sub> in. (mm)	F in. (mm)	G in. (mm)	H in. (mm)	J in. (mm)	WF in. (mm)	WL in. (mm)
OEM 0.1M (B)	2.25 (57,0)	2.63 (67,0)	M10 x 1,0	.12 (3,0)	0.34 (8,6)	1.95 (49,4)	.34 (8,6)	.40 (10,2)	-	-	-
ECO OEM .15M (B)	3.22 (81,8)	3.61 (91,7)	M12 x 1,0	.13 (3,3)	0.34 (8,6)	2.81 (71,4)	.43 (10,9)	.56 (14,2)	-	.43 (11,0)	.38 (9,7)
ECO (LR)OEM .25 (B)	3.22 (81,8)	3.59 (91,2)	½-20 UNF	.13 (3,3)	0.44 (11,2)	2.81 (71,4)	.43 (10,9)	.56 (14,2)	-	.44 (11,2)	.50 (12,7)
ECO (LR)OEM .25M (B)	3.22 (81,8)	3.59 (91,2)	(M14 x 1,5)	.13 (3,3)	0.44 (11,2)	2.81 (71,4)	.43 (10,9)	.56 (14,2)	-	.44 (11,2)	.50 (12,7)
ECO (LR)OEM .35 (B)	3.96 (100,6)	4.36 (110,7)	¾-18 UNF	.16 (4,0)	0.44 (11,2)	3.44 (87,4)	.44 (11,2)	.57 (14,5)	.02 (0,5)	.50 (12,7)	.50 (12,7)
ECO (LR)OEM .35M (B)	3.96 (100,6)	4.36 (110,7)	(M16 x 1,5)	.16 (4,0)	0.44 (11,2)	3.44 (87,4)	.44 (11,2)	.57 (14,5)	.02 (0,5)	.50 (12,7)	.50 (12,7)
ECO (LR)OEM .5 (B)	3.88 (98,6)	4.35 (110,5)	¾-16 UNF	.19 (4,8)	0.50 (12,7)	3.31 (84,1)	.63 (16,0)	.67 (17,0)	-	.68 (17,0)	.50 (12,7)
ECO (LR)OEM .5M (B)	3.88 (98,6)	4.35 (110,5)	(M20 x 1,5)	.19 (4,8)	0.50 (12,7)	3.31 (84,1)	.63 (16,0)	.67 (17,0)	-	.68 (17,0)	.50 (12,7)
ECO (LR)OEM 1.0 (B)	5.12 (130,0)	5.62 (142,7)	1-12 UNF	.25 (6,4)	0.62 (15,7)	4.09 (104,0)	.87 (22,0)	.55 (14,0)	.18 (4,6)	.88 (23,0)	.50 (12,7)
ECO (LR)OEM 1.0M (B)	5.12 (130,0)	5.62 (142,7)	(M27 x 3,0)	.25 (6,4)	0.62 (15,7)	4.09 (104,0)	.87 (22,0)	.55 (14,0)	.18 (4,6)	.88 (23,0)	.50 (12,7)
ECO (LR)OEM 1.0MF (B)	5.12 (130,0)	5.62 (142,7)	(M25 x 1,5)	.25 (6,4)	0.62 (15,7)	4.09 (104,0)	.87 (22,0)	.55 (14,0)	.18 (4,6)	.88 (23,0)	.50 (12,7)

Notes: 1. All shock absorbers will function satisfactorily at 5% of their maximum rated energy per cycle. If less than 5%, a smaller model should be specified.  
2. For mounting accessories, see pages 22-23.  
3. (B) indicates button model of shock absorber. Buttons cannot be added to non-button models or removed from button models OEM .1M to OEM 1.0M.



# Adjustable Series Hydraulic Shock Absorbers

## ECO OEM Small Bore Series

OEM 0.1M → (LR)OEM 1.0 Series

### Accessories

#### Jam Nut (JN)

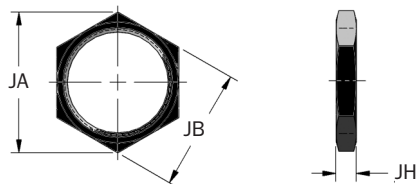

\*Note: One Hex Jam Nut included with every shock absorber.

Catalog No./Model	Part Number	Model (Ref)	JA in. (mm)	JB in. (mm)	JH in. (mm)	Weight (mass) oz. (g)
JN M10 x 1	J223840167	OEM .1M (B)	0.59 (15,0)	0.51 (13,0)	.13 (3,2)	0.1 (2)
JN M12 x 1	J223841035	ECO OEM .15M (B)	0.68 (17,0)	0.59 (15,0)	.16 (4,0)	0.1 (2)
JN 1/2 - 20	J123842166	ECO (LR)OEM .25 (B)	0.72 (19,7)	0.63 (17,0)	.12 (4,0)	0.1 (3)
JN M14 x 1,5	J223842165	ECO (LR)OEM .25M (B)	1.01 (25,4)	0.88 (22,0)	.31 (7,9)	0.6 (15)
JN 1/4 - 18	J123842034	ECO (LR)OEM .35 (B)	1.08 (27,7)	0.94 (24,0)	.18 (4,6)	0.3 (9)
JN M16 x 1,5	J224055035	ECO (LR)OEM .35M (B)	1.30 (33,0)	1.13 (28,8)	.18 (4,6)	0.5 (11)
JN 3/4 - 16	J123844034	ECO (LR)OEM .5 (B)	1.30 (33,0)	1.13 (28,8)	.18 (4,6)	0.5 (11)
JN M20 x 1,5	J223844035	ECO (LR)OEM .5M (B)	1.30 (33,0)	1.13 (28,8)	.18 (4,6)	0.5 (11)
JN 1-12	J123846034	ECO (LR)OEM 1.0 (B)	1.30 (33,0)	1.13 (28,8)	.18 (4,6)	0.5 (11)
JN M27 x 3	J124059034	ECO (LR)OEM 1.0M (B)	1.30 (33,0)	1.13 (28,8)	.18 (4,6)	0.5 (11)
JN M25 x 1,5	J223846035	ECO (LR)OEM 1.0MF (B)	1.30 (33,0)	1.13 (28,8)	.18 (4,6)	0.5 (11)

#### Stop Collar (SC)

Imperial

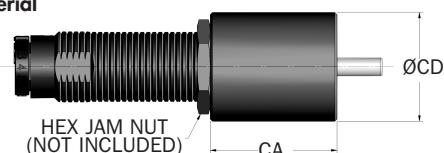

Metric

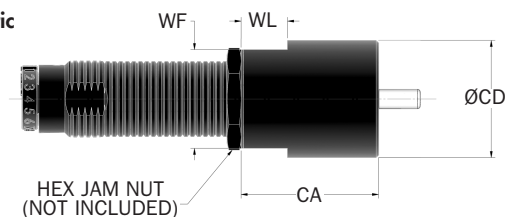

Catalog No./Model	Part Number	Model (Ref)	CA in. (mm)	CD in. (mm)	WF in. (mm)	WL in. (mm)	Weight (mass) oz. (g)
△ SC M10 x 1	M923840171	OEM .1M (B)	0.75 (19,0)	0.63 (16,3)	-	-	0.5 (11)
△ SC M12 x 1	M923841058	OEM .15M (B)	0.75 (19,0)	0.63 (16,0)	-	-	0.5 (11)
△ SC 1/2 - 20	M923842057	(LR)OEM .25 (B)	1.00 (25,4)	0.75 (19,0)	-	-	1.0 (23)
△ SC M14 x 1,5	M923842171	(LR)OEM .25M (B)	1.00 (25,4)	0.69 (17,5)	-	-	1.0 (23)
△ SC 1/4 - 18	M923842199	(LR)OEM .35 (B)	1.00 (25,4)	0.69 (17,5)	-	-	1.0 (23)
△ SC M16 x 1,5	M924055199	(LR)OEM .35M (B)	1.50 (38,0)	1.00 (25,4)	-	-	2.0 (45)
△ SC 3/4 - 16	M923844057	(LR)OEM .5 (B)	1.50 (38,0)	1.00 (25,4)	-	-	2.0 (45)
△ SC M20 x 1,5	M924057058	(LR)OEM .5M (B)	1.50 (38,0)	1.00 (25,4)	-	-	2.0 (45)
△ SC 1-12 x 1	M923846057	(LR)OEM 1.0 (B)	1.75 (44,5)	1.50 (38,0)	-	-	8.0 (180)
△ SC M27 x 3	M923846170	(LR)OEM 1.0M (B)	1.75 (44,5)	1.50 (38,0)	-	-	8.0 (180)
△ SC M25 x 1,5	M923846171	(LR)OEM 1.0MF (B)	1.75 (44,5)	1.50 (38,0)	-	-	8.0 (180)

Notes: 1. \*Do not use with urethane striker cap. 2. △ = Non-standard lead time items, contact ITT Endine.

#### Universal Retaining Flange (Small Bore) (UF)

UF 1/2 - 20

UF M10 x 1 → UF M16 x 1,5

UF 1/4 - 18 → UF 1-12

UF M20 x 1,5 → UF M27 x 3

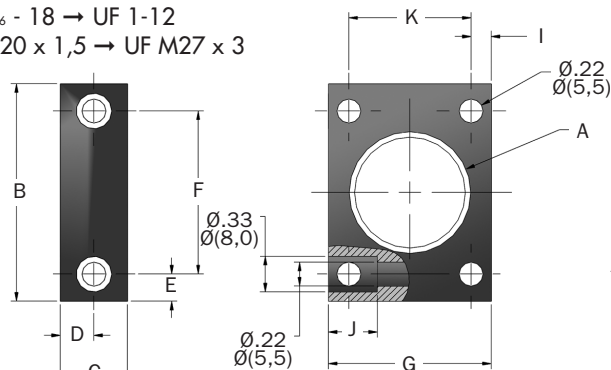
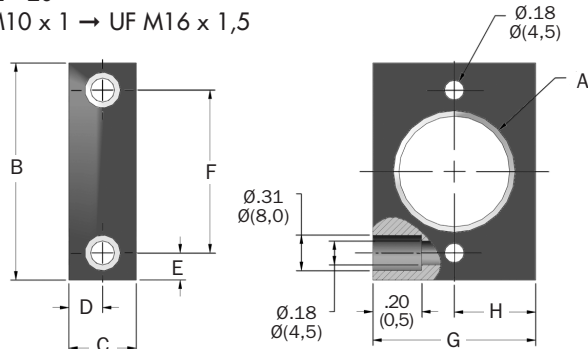

Catalog No./Model	Part Number	Model (Ref)	A in. (mm)	B in. (mm)	C in. (mm)	D in. (mm)	E in. (mm)	F in. (mm)	G in. (mm)	H in. (mm)	I in. (mm)	J in. (mm)	K in. (mm)
△ UF M10 x 1	U16363189	ECO OEM 0.1M(B)	M10 x 1 (M10 x 1)	1.50 (38,0)	.47 (12,0)	.24 (6,0)	.25 (6,25)	1.00 (25,5)	0.98 (25,0)	0.49 (12,5)	-	.20 (5)	-
△ UF M12 x 1	U15588189	ECO OEM .15M(B)	M12 x 1 (M12 x 1)	1.50 (38,0)	.47 (12,0)	.24 (6,0)	.25 (6,25)	1.00 (25,5)	0.98 (25,0)	0.49 (12,5)	-	.20 (5)	-
△ UF 1/2 - 20	U13935095	ECO (LR)OEM .25(B)	1/2 - 20 UNF	1.50 (45,0)	.56 (16,0)	.28 (8,0)	.25 (5,0)	1.00 (35,0)	1.00 (30,0)	0.50 (15,0)	-	.20 (5)	-
△ UF M14 x 1,5	U13935143	ECO (LR)OEM .25M	(M14 x 1,5)	1.50 (45,0)	.56 (16,0)	.28 (8,0)	.25 (5,0)	1.00 (35,0)	1.00 (30,0)	0.50 (15,0)	-	.20 (5)	-
△ UF M16 x 1,5	U19018143	ECO (LR)OEM .35M	(M16 x 1,5)	1.50 (45,0)	.56 (16,0)	.28 (8,0)	.25 (5,0)	1.00 (35,0)	1.00 (30,0)	0.50 (15,0)	-	.20 (5)	-
△ UF 3/4 - 16	U120275095	ECO (LR)OEM .5(B)	3/4 - 16 UNF	2.00 (48,0)	.62 (16,0)	.31 (8,0)	.25 (6,5)	1.50 (35,0)	1.50 (35,0)	-	.19 (4,75)	.45 (11,4)	1.12 (25,5)
△ UF M20 x 1,5	U1202646143	ECO (LR)OEM .5M	(M20 x 1,5)	2.00 (48,0)	.62 (16,0)	.31 (8,0)	.25 (6,5)	1.50 (35,0)	1.50 (35,0)	-	.19 (4,75)	.45 (11,4)	1.12 (25,5)
△ UF 1-12	U19599095	ECO (LR)OEM 1.0(B)	1-12 UNF	2.00 (48,0)	.62 (16,0)	.31 (8,0)	.25 (6,5)	1.50 (35,0)	1.50 (35,0)	-	.19 (4,75)	.45 (11,4)	1.12 (25,5)
△ UF M25 x 1,5	U12584143	ECO (LR)OEM 1.0MF	(M25 x 1,5)	2.00 (48,0)	.62 (16,0)	.31 (8,0)	.25 (6,5)	1.50 (35,0)	1.50 (35,0)	-	.19 (4,75)	.45 (11,4)	1.12 (25,5)
△ UF M27 x 3	U12587143	ECO (LR)OEM 1.0M	(M27 x 3)	2.00 (48,0)	.62 (16,0)	.31 (8,0)	.25 (6,5)	1.50 (35,0)	1.50 (35,0)	-	.19 (4,75)	.45 (11,4)	1.12 (25,5)

⊗ = Non-standard lead time items, contact Endine.

Adjustable Series

OEM 0.1M → OEM 1.0 Series

**Side Load Adaptor (SLA)**

**Adjustable Series**

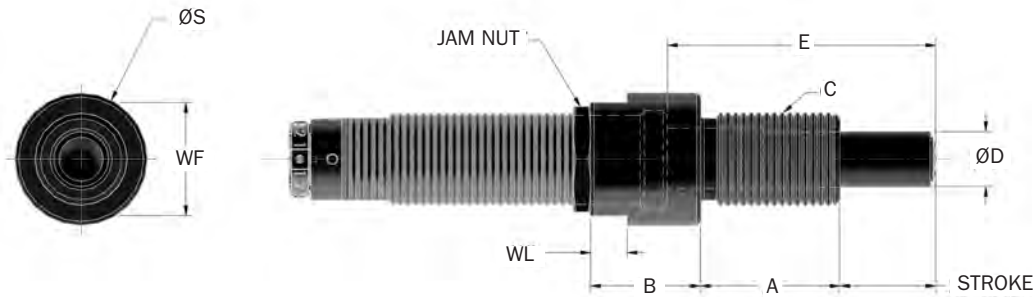

Catalog No./Model	Part Number	Model (Ref)	Stroke in. (mm)	A in. (mm)	B in. (mm)	C in. (mm)	D in. (mm)	E in. (mm)	S in. (mm)	WF in. (mm)	WL in. (mm)
<b>SLA 10MF</b>	SLA 33457	ECO OEM 0.1M	.25 (6,4)	.47 (12)	.43 (11)	M10 x 1	.20 (5)	.85 (21,9)	.51 (13)	11 (11)	.28 (0,28)
<b>SLA 12MF</b>	SLA 33299	ECO OEM .15M	.38 (10,0)	.71 (18)	.55 (14)	M12 x 1	.24 (6)	1.28 (32,4)	.63 (16)	13 (13)	.28 (0,28)
<b>SLA 1/2 - 20 x .38</b>	SLA 71133	ECO (LR)OEM .25	.38 (10,0)	.71 (18)	.65 (16)	1/2 - 20 UNF	.31 (8)	1.37 (34,3)	.71 (18)	.63 (15)	.28 (7,0)
<b>SLA 14MC</b>	SLA 34756	ECO (LR)OEM .25M				(M14 x 1,5)					
<b>SLA 9/16 - 18 x .50</b>	SLA 71134	ECO (LR)OEM .35	.5 (12,7)	.79 (20)	.63 (16)	9/16 - 18 UNF	.31 (8)	1.55 (39,2)	.71 (20)	.63 (17)	.28 (7,0)
<b>SLA 16 MF</b>	SLA 34757	ECO (LR)OEM .35M				(M16 x 1,5)					
<b>SLA 3/4 - 16 x .50</b>	SLA 33847	ECO (LR)OEM .5	.5 (12,7)	.94 (24)	.55 (14)	3/4 - 16 UNF	.43 (11)	1.64 (41,5)	.98 (25)	.88 (22)	.28 (7,0)
<b>SLA 20 MC</b>	SLA 33262	ECO (LR)OEM .5M				(M20 x 1,5)					
<b>SLA 1-12 x 1</b>	SLA 33848	ECO (LR)OEM 1.0	1.0 (25,0)	1.50 (38)	1.80 (30)	1-12 UNF	.59 (15)	2.88 (73,2)	1.42 (36)	1.25 (32)	.39 (0,28)
<b>SLA 25 MF</b>	SLA 33263	ECO (LR)OEM 1.0MF				(M25 x 1,5)					
<b>SLA 27 MC</b>	SLA 33296	ECO (LR)OEM 1.0M				(M27 x 3)					

Notes: 1. Maximum sideload angle is 30°. 2. Part Numbers in page color are non-standard lead time items, contact ITT Enidine.

**Clevis Mount**



Catalog No./Model	(S) Stroke in. (mm)	L in. (mm)	M +0.010/-0.000 in. (mm)	N +0.010/-0.000 in. (mm)	P +0.000/-0.010 in. (mm)	Q in. (mm)	S in. (mm)	V in. (mm)	W in. (mm)	X in. (mm)	Weight (mass) oz. (g)
<b>Δ ECO OEM 1.0 CMS</b>	1.0	6.38	.141 +0.005/-0.000	.251 +0.005/-0.000	.375 +0.000/-0.010	.25	1.25	.13	.35	.25	13.9
<b>Δ ECO OEM 1.0M CMS</b>	25	162,1	3,58 +0,13/0	6,02 +0,13/0	9,5 0/0,3	6,4	31,8	3,2	9,0	6,4	394

Notes: 1. Maximum sideload angle is 30°. 2. Δ = Non-standard lead time items, contact ITT Enidine.

# Adjustable Series Hydraulic Shock Absorbers

## ECO OEM Small Bore Series

OEM 1.15 → (LR)OEM 1.25 Series

### Technical Data

### Standard

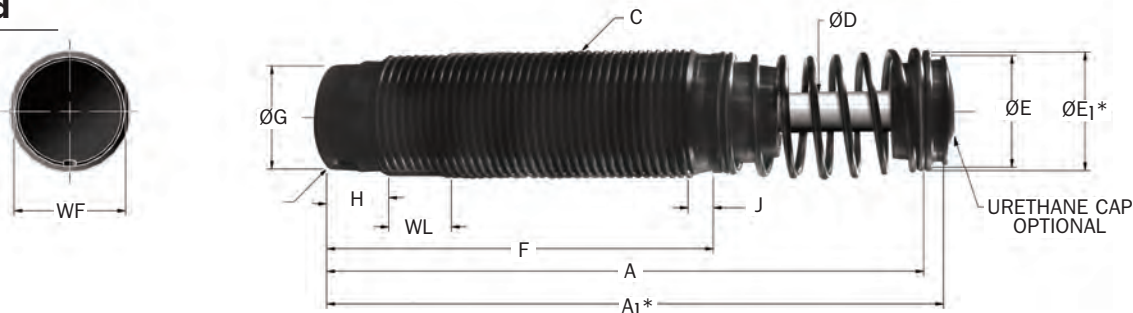

\*Note: A<sub>1</sub> and E<sub>1</sub> apply to urethane striker cap accessory.

Catalog No./Model	(S) Stroke in. (mm)	Optimal Velocity Range in./sec. (m/s)	(E <sub>T</sub> ) Max. in.-lbs./cycle (Nm/cycle)	(E <sub>T</sub> C) Max. in.-lbs./hour (Nm/h)	(F <sub>P</sub> ) Max. Reaction Force lbs. (N)	Nominal Coil Spring Force		(F <sub>P</sub> ) Max. Propelling Force lbs. (N)	Weight (mass) oz (g)
						Extended lbs. (N)	Compressed lbs. (N)		
△ ECO OEM 1.15 x 1	1.00	12-130	1,900	137,000	2,500	12.5	20.0	500	17
△ ECO OEM 1.15M x 1	(25,0)	(0,3-3,30)	(215,0)	(83 300)	(11 120)	(56,0)	(89,0)	(2 220)	(482)
△ ECO LROEM 1.15 x 1	1.00	3-80	1,900	237,000	2,500	12.5	20.0	750	17
△ ECO LROEM 1.15M x 1	(25,0)	(0,08-2,0)	(215,0)	(83 300)	(11 120)	(56,0)	(89,0)	(3 335)	(482)
△ ECO OEM 1.15 x 2	2.00	12-130	3,750	963,000	2,500	7.0	20.0	500	25
△ ECO OEM 1.15M x 2	(50,0)	(0,3-3,30)	(424,0)	(108 800)	(11 120)	(31,0)	(89,0)	(2 220)	(708)
△ ECO LROEM 1.15 x 2	2.00	3-80	3,750	963,000	2,500	7.0	20.0	750	25
△ ECO LROEM 1.15M x 2	(50,0)	(0,08-2,0)	(424,0)	(108 800)	(11 120)	(31,0)	(89,0)	(3 335)	(708)
△ ECO OEM 1.25 x 1	1.00	12-130	1,900	886,000	2,500	12.5	20.0	500	20
△ ECO OEM 1.25M x 1	(25,0)	(0,3-3,30)	(215,0)	(100 100)	(11 120)	(56,0)	(89,0)	(2 220)	(567)
△ ECO LROEM 1.25 x 1	1.00	3-80	1,900	886,000	2,500	12.5	20.0	750	20
△ ECO LROEM 1.25M x 1	(25,0)	(0,08-2,0)	(215,0)	(100 100)	(11 120)	(56,0)	(89,0)	(3 335)	(567)
△ ECO OEM 1.25 x 2	2.00	12-130	3,750	1,084,000	2,500	7.0	20.0	500	26
△ ECO OEM 1.25M x 2	(50,0)	(0,3-3,30)	(424,0)	(122 500)	(11 120)	(31,0)	(89,0)	(2 220)	(737)
△ ECO LROEM 1.25 x 2	2.00	3-80	3,750	1,084,000	2,500	7.0	20.0	750	26
△ ECO LROEM 1.25M x 2	(50,0)	(0,08-2,0)	(424,0)	(122 500)	(11 120)	(31,0)	(89,0)	(3 335)	(737)

Catalog No./Model	A in. (mm)	A <sub>1</sub> in. (mm)	C in. (mm)	D in. (mm)	E in. (mm)	E <sub>1</sub> in. (mm)	F in. (mm)	G in. (mm)	H in. (mm)	J in. (mm)	WF in. (mm)	WL in. (mm)
△ ECO (LR)OEM 1.15 x 1	5.92	6.12	1 ¼ - 12 UNF	.38	1.13	1.20	3.81	1.10	.55	.21	1.12	.63
△ ECO (LR)OEM 1.15M x 1	(150,0)	(155,5)	(M33 x 1,5)	(9,5)	(29,0)	(30,5)	(97,0)	(28,0)	(14,0)	(5,3)	(30,0)	(16,0)
△ ECO (LR)OEM 1.15 x 2	8.54	8.74	1 ¼ - 12 UNF	.38	1.13	1.20	5.43	1.10	.55	.21	1.12	.63
△ ECO (LR)OEM 1.15M x 2	(217,0)	(222,0)	(M33 x 1,5)	(9,5)	(29,0)	(30,5)	(138,0)	(28,0)	(14,0)	(5,3)	(30,0)	(16,0)
△ ECO (LR)OEM 1.25 x 1	5.92	6.12	1 ¼ - 12 UNF	.38	1.13	1.20	3.81	1.10	.55	.21	1.25	.63
△ ECO (LR)OEM 1.25M x 1	(150,0)	(155,5)	(M36 x 1,5)	(9,5)	(29,0)	(30,5)	(97,0)	(28,0)	(14,0)	(5,3)	(33,0)	(16,0)
△ ECO (LR)OEM 1.25 x 2	8.54	8.74	1 ¼ - 12 UNF	.38	1.13	1.20	5.43	1.10	.55	.21	1.25	.63
△ ECO (LR)OEM 1.25M x 2	(217,0)	(222,0)	(M36 x 1,5)	(9,5)	(29,0)	(30,5)	(138,0)	(28,0)	(14,0)	(5,3)	(33,0)	(16,0)

- Notes: 1. All shock absorbers will function satisfactorily at 5% of their maximum rated energy per cycle. If less than 5%, a smaller model should be specified.
- 2. For mounting accessories, see pages 25-26.
- 3. Urethane striker caps are available as accessories for models OEM 1.15M x 1 to OEM 1.25M x 2.
- 4. △ = Non-standard lead time items, contact ITT Enidine.

### Urethane Striker Cap (USC)

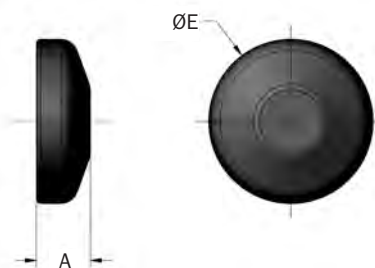

Catalog No./Model	Part Number	Model (Ref)	A in. (mm)	E in. (mm)	Weight (mass) oz. (g)
UC 8609	C98609079	ECO (LR)OEM 1.15/1.25	.39 (10,0)	1.20 (30,5)	0.2 (6)

Adjustable Series

OEM 1.15 → OEM 1.25 Series

**Jam Nut (JN)**

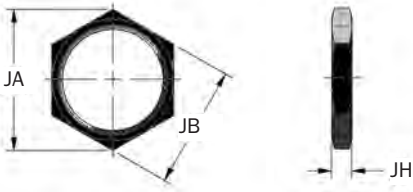

Catalog No./ Model	Part Number	Model (Ref)	JA in. (mm)	JB in. (mm)	JH in. (mm)	Weight (mass) oz. (g)
JN 1 1/4 - 12	J124061034	ECO OEM 1.15	1.73	1.50	.25	0.8
JN M33 x 1,5	J224061035	ECO (LR)OEM 1.15M	(44,0)	(38,0)	(6,4)	(23)
JN 1 3/8 - 12	J124063034	ECO OEM 1.25	1.88	1.63	.25	0.9
JN M36 x 1,5	J224063035	ECO (LR)OEM 1.25M	(47,3)	(41,0)	(6,4)	(26)

**Stop Collar (SC)**

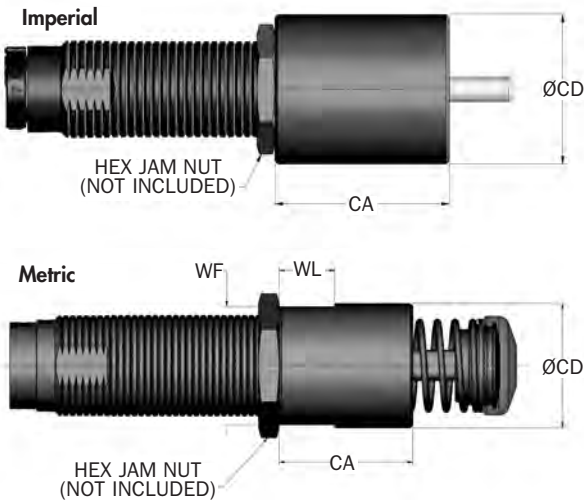

Catalog No./ Model	Part Number	Model (Ref)	CA in. (mm)	CD in. (mm)	WF in. (mm)	WL in. (mm)	Weight (mass) oz. (g)
△ SC 1 1/4 - 12	M924061057	ECO OEM 1.15	2.50	1.50	-	-	7.0
△ SC M33 x 1.5	M924061058	ECO OEM 1.15M	(63,5)	(38,1)	-	-	(215)
△ SC 1 3/8 - 12	M924063057	ECO OEM 1.25	2.50	1.69	-	-	7.0
△ SC M36 x 1,5	M924063058	ECO OEM 1.25M	(63,5)	(43,0)	(41,0)	(18,0)	(210)
△ SC 1-12HP x 1.56	M924129181	HP 110	2.00	1.50	-	-	-
△ SC M25 x 2 x 1,56	M924129058	HP 110 MC	(50,8)	(38,0)	(32,0)	(15,0)	8.0
△ SC M25 x 1,5 x 1,56	M924129180	HP 110 MF	(50,8)	(38,0)	(32,0)	(15,0)	(215)

Notes: 1. \*Do not use with urethane striker cap. 2. △ = Non-standard lead time items, contact Enidine.

**Rectangular Flange (RF)**

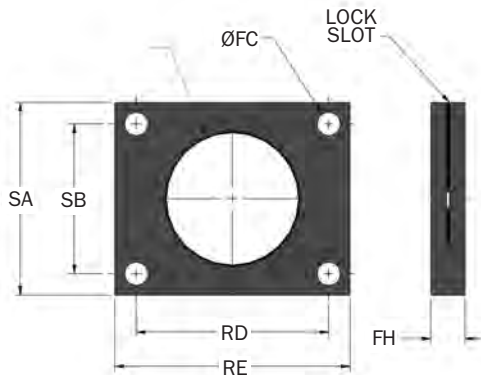

Catalog No./ Model	Part Number	Model (Ref)	FC in. (mm)	FH in. (mm)	RD in. (mm)	RE in. (mm)	SA in. (mm)	SB in. (mm)	Bolt Size in. (mm)	Wt. (mass) oz. (g)
RF 1 1/4 - 12	N121049129	ECO (LR)OEM 1.15	.22	.38	1.63	2.00	1.75	1.13	#10	1.0
RF M33 x 1,5	N121049141	ECO (LR)OEM 1.15M	(5,5)	(9,5)	(41,3)	(50,8)	(44,5)	(28,6)	(M5)	(30)
RF 1 3/8 - 12	N121293129	ECO (LR)OEM 1.25	.22	.38	1.63	2.00	1.75	1.13	#10	1.0
RF M36 x 1,5	N121293141	ECO (LR)OEM 1.25M	(5,5)	(9,5)	(41,3)	(58,8)	(44,5)	(28,6)	(M5)	(30)

# Adjustable Series Hydraulic Shock Absorbers

## ECO OEM Small Bore Series

### Accessories

OEM 1.15 → OEM 1.25 Series

### Clevis Mount



Catalog No./Model	(S) Stroke in. (mm)	L in. (mm)	M in. (mm)	N in. (mm)	P in. (mm)	Q in. (mm)	S in. (mm)	T in. (mm)	V in. (mm)	W in. (mm)	X in. (mm)	CR in. (mm)	Weight (mass) oz. (g)
Δ ECO (LR)OEM 1.15 x 1 CM(S)	1.0 (25)	6.44 (163,6)	.251 (6,02)	.251 (6,02)	.500 (12,7)	.500 (12,7)	1.50 (38,1)	.88 (22,3)	.23 (6,0)	.33 (8,3)	.23 (5,9)	.44 (10,0)	1.6 (725)
Δ ECO (LR)OEM 1.15 x 2 CM(S)	2.0 (50)	9.07 (230,4)	.251 (6,02)	.251 (6,02)	.500 (12,7)	.500 (12,7)	1.50 (38,1)	.88 (22,3)	.23 (6,0)	.33 (8,3)	.23 (5,9)	.44 (10,0)	1.6 (861)
Δ ECO (LR)OEM 1.25 x 1 CM(S)	1.0 (25)	6.44 (163,6)	.251 (6,02)	.251 (6,02)	.500 (12,7)	.500 (12,7)	1.50 (38,1)	.88 (22,3)	.23 (6,0)	.33 (8,3)	.23 (5,9)	.44 (10,0)	1.6 (725)
Δ ECO (LR)OEM 1.25 x 2 CM(S)	2.0 (50)	9.07 (230,4)	.251 (6,02)	.251 (6,02)	.500 (12,7)	.500 (12,7)	1.50 (38,1)	.88 (22,3)	.23 (6,0)	.33 (8,3)	.23 (5,9)	.44 (10,0)	1.9 (861)

Notes: 1. "S" designates model is supplied with spring. 2. Δ = Non-standard lead time items, contact ITT Enidine.

### Flange Foot Mount

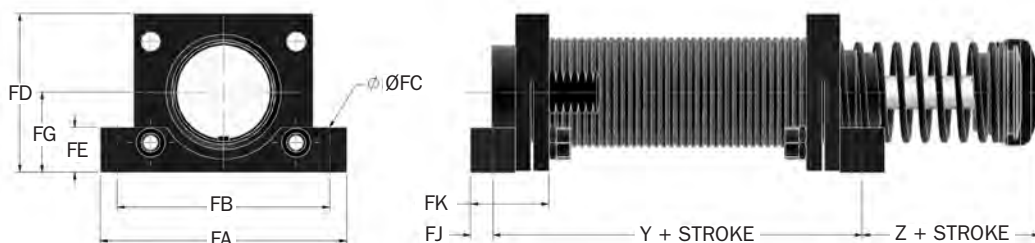

Catalog No./Model	Part Number	Model (Ref)	Y in. (mm)	Z in. (mm)	FA in. (mm)	FB in. (mm)	FC in. (mm)	FD in. (mm)	FE in. (mm)	FG in. (mm)	FJ in. (mm)	FK in. (mm)	Size in. (mm)	Bolt Weight lbs. (kg)
FM 1 1/4 - 12	2F21049305	ECO (LR)OEM 1.15	2.23	1.25	2.75	2.38	.23	1.75	0.50	0.90	0.25	0.88	#10	4.0 oz.
FM 1 3/8 - 12	2F21293305	ECO (LR)OEM 1.25	2.23	1.25	2.75	2.38	.23	1.75	0.50	0.90	0.25	0.88	#10	4.0 oz.
FM M33 x 1,5	2F21049306	ECO (LR)OEM 1.15M	(56,6)	(31,8)	(70,0)	(60,3)	(6,0)	(44,5)	(12,7)	(22,7)	(6,4)	(22,2)	(M5)	(100g)
FM M36 x 1,5	2F21293306	ECO (LR)OEM 1.25M	(56,6)	(31,8)	(70,0)	(60,3)	(6,0)	(44,5)	(12,7)	(22,7)	(6,4)	(22,2)	(M5)	(100g)

Adjustable Series

OEMXT 3/4 & OEMXT 1.5M Series

### Standard

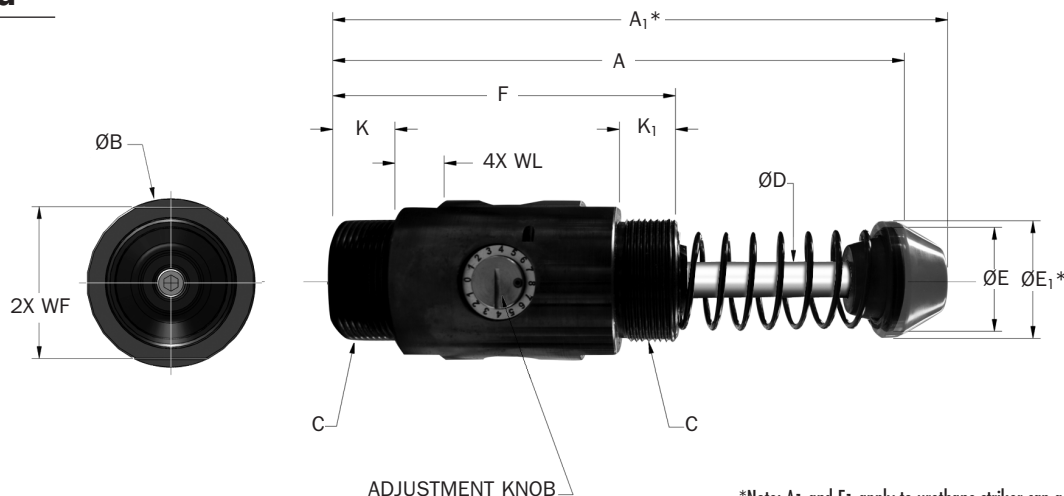

\*Note: A<sub>1</sub> and E<sub>1</sub> apply to urethane striker cap accessory.

Imperial Catalog No./Model	(S) Stroke in.	Optimal Velocity Range in./sec.	(E <sub>T</sub> ) Max. in.-lbs./cycle	(E <sub>T-C</sub> ) Max. in.-lbs./hour	(F <sub>p</sub> ) Max. Reaction Force lbs.	Nominal Coil Spring Force		(F <sub>D</sub> ) Max. Propelling Force lbs.	Weight lbs.
						Extended lbs.	Compressed lbs.		
OEMXT 3/4 x 1	1	12-140	3,750	1,120,000	4,500	11	15	650	2.7
LROEMXT 3/4 x 1	1	3-55	3,750	1,120,000	4,500	11	15	1,500	2.7
OEMXT 3/4 x 2	2	12-140	7,500	1,475,000	4,500	7	15	650	3.7
LROEMXT 3/4 x 2	2	3-55	7,500	1,475,000	4,500	11	18	1,500	3.7
OEMXT 3/4 x 3	3	12-140	11,500	1,775,000	4,500	7	18	650	4.6

Metric Catalog No./Model	(S) Stroke mm	Optimal Velocity Range m/sec.	(E <sub>T</sub> ) Max. Nm/cycle	(E <sub>T-C</sub> ) Max. Nm/hour	(F <sub>p</sub> ) Max. Reaction Force N	Nominal Coil Spring Force		(F <sub>D</sub> ) Max. Propelling Force N	Mass Kg
						Extended N	Compressed N		
OEMXT 1.5M x 1	25,0	0,3-3,5	425	126 000	20 000	48	68	2 890	1,2
LROEMXT 1.5M x 1	25,0	0,08-1,3	425	126 000	20 000	48	68	6 660	1,2
OEMXT 1.5M x 2	50,0	0,3-3,5	850	167 000	20 000	29	68	2 890	1,7
LROEMXT 1.5M x 2	50,0	0,08-1,3	850	167 000	20 000	48	85	6 660	1,7
OEMXT 1.5M x 3	75,0	0,3-3,5	1 300	201 000	20 000	29	85	2 890	2,1

Imperial Catalog No./Model	C in.	A in.	A <sub>1</sub> in.	B in.	D in.	E in.	E <sub>1</sub> in.	F in.	K in.	K <sub>1</sub> in.	WF in.	WL in.
(LR)OEMXT 3/4 x 1	1 3/4 - 12 UN	5.68	6.38	2.25	0.50	1.50	1.75	3.63	0.91	0.82	1.59	0.75
(LR)OEMXT 3/4 x 2	1 3/4 - 12 UN	7.68	8.38	2.25	0.50	1.50	1.75	4.63	0.91	0.82	1.59	0.75
(LR)OEMXT 3/4 x 3	1 3/4 - 12 UN	9.68	10.38	2.25	0.50	1.50	1.75	5.63	0.91	0.82	1.59	0.75

Metric Catalog No./Model	C mm	A mm	A <sub>1</sub> mm	B mm	D mm	E mm	E <sub>1</sub> mm	F mm	K mm	K <sub>1</sub> mm	WF mm	WL mm
(LR)OEMXT 1.5M x 1	M42 x 1.5	144	162	58	13	38	44	92	32	32	40,5	19
(LR)OEMXT 1.5M x 2	M42 x 1.5	195	213	58	13	38	44	118	45	45	40,5	19
(LR)OEMXT 1.5M x 3	M42 x 1.5	246	264	58	13	38	44	143	57	57	40,5	19
(LR)OEMXT 45M x 1	M45 x 1.5	144	162	58	13	38	44	92	32	32	40,5	19
(LR)OEMXT 45M x 2	M45 x 1.5	195	213	58	13	38	44	118	45	45	40,5	19
(LR)OEMXT 45M x 3	M45 x 1.5	246	264	58	13	38	44	143	57	57	40,5	19

Notes: 1. For OEMXT 45M Series Accessories please see page 66 under PMXT Mid-Bore.

# Adjustable Series Hydraulic Shock Absorbers

## OEMXT Mid-Bore Series

OEMXT 3/4 & (LR)OEMXT 1.5M Series

Accessories

### Clevis Mount

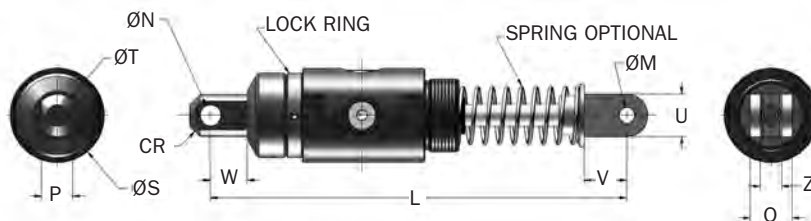

Catalog No./Model	(S) Stroke in. (mm)	L in. (mm)	M in. (mm)	N in. (mm)	P in. (mm)	Q in. (mm)	S in. (mm)	T in. (mm)	U in. (mm)	V in. (mm)	W in. (mm)	Z in. (mm)	CR in. (mm)	Weight (mass) lbs. (Kg)
Δ(LR)OEMXT 3/4 x 1 CM(S)	1.0	7.84 +0.010/-0.000	.376 +0.010/-0.000	.501 +0.000/-0.010	.750	1.00	2.00	1.00	1.00	1.01	.87 +0.020/-0.000	.505	.56	3.5
Δ(LR)OEMXT 1.5M x 1 CM(S)	(25)	(199,0)	(9,60) (+0,25/0)	(12,70) (+0,25/0)	(19,0) (0/-0,3)	(25,4)	(51,0)	(25,4)	(25,0)	(26,0)	(22,0)	(12,9) (+0,5/-0)	(14,3)	(1,59)
Δ(LR)OEMXT 3/4 x 2 CM(S)	2.0	9.84	.376 +0.010/-0.000	.501 +0.010/-0.000	.750 +0.000/-0.010	1.00	2.00	1.00	1.00	1.01	.87	.505 +0.020/-0.000	.56	3.8
Δ(LR)OEMXT 1.5M x 2 CM(S)	(50)	(250,0)	(9,60) (+0,25/0)	(12,70) (+0,25/0)	(19,0) (0/-0,3)	(25,4)	(51,0)	(25,4)	(25,0)	(26,0)	(22,0)	(12,9) (+0,5/-0)	(14,3)	(1,7)
ΔOEMXT 3/4 x 3 CM(S)	3.0	11.84	.376 +0.010/-0.000	.501 +0.010/-0.000	.750 +0.000/-0.010	1.00	2.00	1.00	1.00	1.01	.87	.505 +0.020/-0.000	.56	4.3
ΔOEMXT 1.5M x 3 CM(S)	(75)	(300,0)	(9,60) (+0,25/0)	(12,70) (+0,25/0)	(19,0) (0/-0,3)	(25,4)	(51,0)	(25,4)	(25,0)	(26,0)	(22,0)	(12,9) (+0,5/-0)	(14,3)	(1,95)

Notes: 1. "S" designates model is supplied with spring. 2. Δ = Non-standard lead time items, contact ITT Enidine.

### Flange Foot Mount

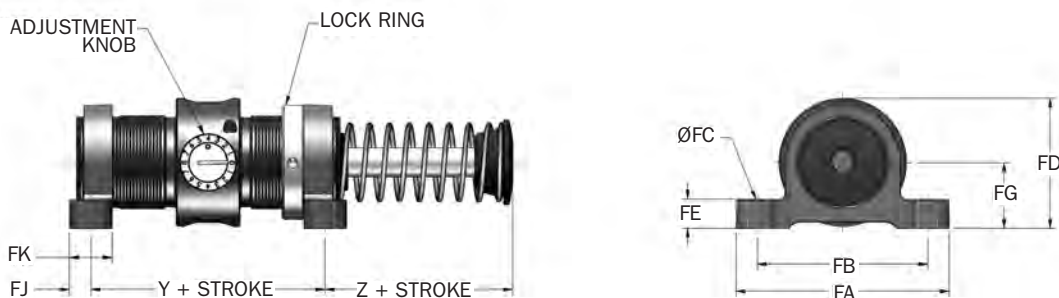

Catalog No./Model	Part Number	Model (Ref)	Y in. (mm)	Z in. (mm)	FA in. (mm)	FB in. (mm)	FC in. (mm)	FD in. (mm)	FE in. (mm)	FG in. (mm)	FJ in. (mm)	FK in. (mm)	Bolt Size in. (mm)	Weight (mass) lbs. (Kg)
FM 1 3/4-12	2FE2940	(LR)OEM 3/4	2.38	1.06	3.75	3.00	.34	2.16	0.50	1.16	0.38	0.75	3/16	12.0 oz.
FM M42 x 1.5	2F2940	(LR)OEM 1.5M	(60,5)	(26,9)	(95,3)	(76,2)	(8,6)	(55,0)	(12,7)	(29,5)	(9,7)	(19,1)	(M8)	(370)g

Adjustable Series

OEMXT 1-1/8 & OEMXT 2.0M Series

### Standard

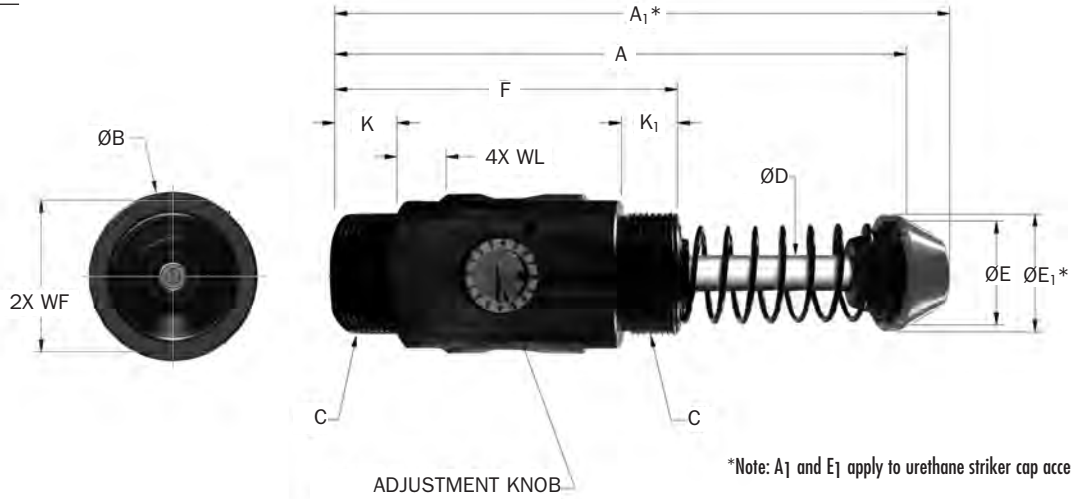

\*Note: A1 and E1 apply to urethane striker cap accessory.

Imperial Catalog No./Model	(S) Stroke in.	Optimal Velocity Range in./sec.	(E <sub>T</sub> ) Max. in.-lbs./cycle	(E <sub>T</sub> C) Max. in.-lbs./hour	(F <sub>P</sub> ) Max. Reaction Force lbs.	Nominal Coil Spring Force		(F <sub>P</sub> ) Max. Propelling Force lbs.	Weight lbs.
						Extended lbs.	Compressed lbs.		
Δ(LR)OEMXT 1 1/8 x 1	1	3-30	10,000	2,000,000	11,500	26	35	4,000	4.5
OEMXT 1 1/8 x 2	2	12-140	20,000	2,400,000	11,500	17	35	1,500	7.9
(LR)OEMXT 1 1/8 x 2	2	3-30	20,000	2,400,000	11,500	17	35	4,000	7.9
OEMXT 1 1/8 x 4	4	12-140	40,000	3,200,000	11,500	16	36	1,500	10.8
OEMXT 1 1/8 x 6	6	12-140	60,000	3,730,000	11,500	20	64	1,500	14.1
Metric Catalog No./Model	(S) Stroke mm	Optimal Velocity Range m/sec.	(E <sub>T</sub> ) Max. Nm/cycle	(E <sub>T</sub> C) Max. Nm/hour	(F <sub>P</sub> ) Max. Reaction Force N	Nominal Coil Spring Force		(F <sub>P</sub> ) Max. Propelling Force N	Mass Kg
Δ(LR)OEMXT 2.0M x 1	25,0	0,08-1,35	1 130	226 000	51 000	115	155	17 760	2,1
OEMXT 2.0M x 2	50,0	0,3-3,5	2 260	271 000	51 000	75	155	6 660	3,6
LROEMXT 2.0M x 2	50,0	0,08-1,35	2 260	271 000	51 000	75	155	17 760	3,6
OEMXT 2.0M x 4	100,0	0,3-3,5	4 520	362 000	51 000	70	160	6 660	4,9
OEMXT 2.0M x 6	150,0	0,3-3,5	6 780	421 000	51 000	90	284	6 660	6,4

Note: Δ = Non-standard lead time items, contact ITT Enidine.

Imperial Catalog No./Model	C in.	A in.	A <sub>1</sub> in.	B in.	D in.	E in.	E <sub>1</sub> in.	F in.	K in.	K <sub>1</sub> in.	WF in.	WL in.
Δ(LR)OEMXT 1 1/8 x 1	2 1/2 - 12 UN	6.90	7.55	3.00	0.75	2.00	2.25	4.50	1.03	1.03	2.75	1.00
(LR)OEMXT 1 1/8 x 2	2 1/2 - 12 UN	8.90	9.55	3.00	0.75	2.00	2.25	5.50	1.03	1.03	2.75	1.00
OEMXT 1 1/8 x 4	2 1/2 - 12 UN	12.90	13.59	3.00	0.75	2.00	2.25	7.50	1.03	1.03	2.75	1.00
OEMXT 1 1/8 x 6	2 1/2 - 12 UN	17.97	18.62	3.00	0.75	2.38	2.38	9.50	1.03	1.03	2.75	1.00
Metric Catalog No./Model	C mm	A mm	A <sub>1</sub> mm	B mm	D mm	E mm	E <sub>1</sub> mm	F mm	K mm	K <sub>1</sub> mm	WF mm	WL mm
Δ(LR)OEMXT 2.0M x 1	M64 x 2.0	175	192	77	19	50	57	114	38	38	61.5	25
LROEMXT 2.0M x 2	M64 x 2.0	226	243	77	19	50	57	140	50	50	61.5	25
OEMXT 2.0M x 4	M64 x 2.0	328	345	77	19	50	57	191	75	75	61.5	25
OEMXT 2.0M x 6	M64 x 2.0	456	473	77	19	57	57	241	75	75	61.5	25

Note: Δ = Non-standard lead time items, contact ITT Enidine.



# Adjustable Series Hydraulic Shock Absorbers

## OEMXT Mid-Bore Series Accessories

OEMXT 1-1/8 & OEMXT 2.0M Series

Accessories

### Clevis Mount

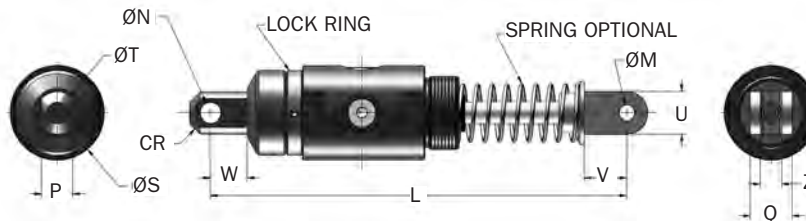

Catalog No./Model	(S) Stroke in. (mm)	L in. (mm)	M in. (mm)	N in. (mm)	P in. (mm)	Q in. (mm)	S in. (mm)	T in. (mm)	U in. (mm)	V in. (mm)	W in. (mm)	Z in. (mm)	CR in. (mm)	Weight (mass) lbs. (Kg)
Δ(LR)OEMXT 1 1/8 x 2 CM(S)	2.0	12.06	.751 +0.010/-0.000	.751 +0.010/-0.000	1.250 +0.000/-0.010	1.50 +0.030/-0.030	2.88	1.50	1.50	1.40	1.06	.640 +0.010/-0.010	.90	11.7
Δ(LR)OEMXT 2.0M x 2 CM (S)	(50)	(306,0)	(19,07) (+0,25/0)	(19,07) (+0,25/0)	(31,7) (0/-0,3)	(38,1) (+0,8/-0,8)	(73,0)	(38,1)	(38,0)	(36,0)	(26,0)	(16,3) (+0,25/-0,25)	(23,0)	(5,30)
ΔOEMXT 1 1/8 x 4 CM(S)	4.0	16.06	.751 +0.010/-0.000	.751 +0.010/-0.000	1.250 +0.000/-0.010	1.50 +0.030/-0.030	2.88	1.50	1.50	1.40	1.06	.640 +0.010/-0.010	.90	13.4
ΔOEMXT 2.0M x 4 CM(S)	(100)	(408,0)	(19,07) (+0,25/0)	(19,07) (+0,25/0)	(31,7) (0/-0,3)	(38,1) (+0,8/-0,8)	(73,0)	(38,0)	(38,0)	(36,0)	(26,0)	(16,3) (+0,25/-0,25)	(23,0)	(6,08)
ΔOEMXT 1 1/8 x 6 CM(S)	6.0	21.13	.751 +0.010/-0.000	.751 +0.010/-0.000	1.250 +0.000/-0.010	1.50 +0.030/-0.030	2.88	1.50	1.50	1.40	1.06	.640 +0.010/-0.010	.90	16.3
ΔOEMXT 2.0M x 6 CM(S)	(150)	(537,0)	(19,07) (+0,25/0)	(19,07) (+0,25/0)	(31,7) (0/-0,3)	(38,1) (+0,8/-0,8)	(73,0)	(38,0)	(38,0)	(36,0)	(26,0)	(16,3) (+0,25/-0,25)	(23,0)	(7,39)

Notes: 1. "S" designates model is supplied with spring. 2. Δ = Non-standard lead time items, contact ITT Enidine.

### Flange Foot Mount

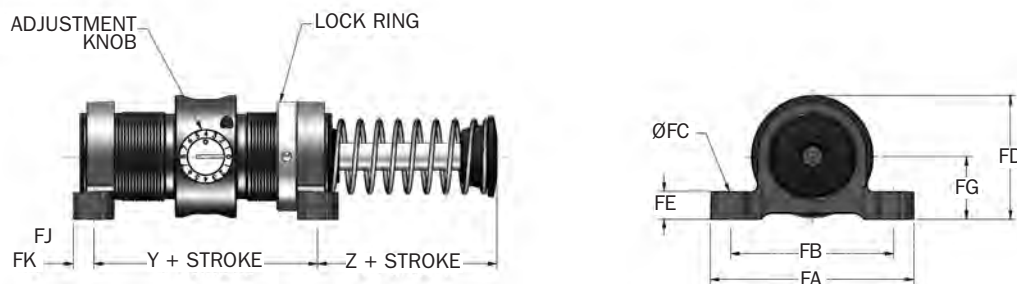

Catalog No./Model	Part Number	Model (Ref)	Y in. (mm)	Z in. (mm)	FA in. (mm)	FB in. (mm)	FC in. (mm)	FD in. (mm)	FE in. (mm)	FG in. (mm)	FJ in. (mm)	FK in. (mm)	Bolt Size in. (mm)	Weight (mass) lbs. (kg)	Notes
FM 2 1/2 - 12	2FE3010	(LR)OEM 1 1/8	3.00	1.56	5.63	4.88	.41	3.38	0.63	1.75	0.44	0.88	3/8	2.3	1
FM M64 x 2	2F3010	(LR)OEM 2.0M	(76,2)	(39,6)	(143,0)	(124,0)	(10,4)	(89,7)	(16,0)	(44,5)	(11,2)	(22,4)	M10	(1.08)	2

Notes: 1. OEM 1 1/8 x 6 'Z' dimension is 2.69 in.  
2. OEM 2.0M x 6 'Z' dimension is 68,3 mm

OEM 3.0M → OEM 4.0M Series

### Standard

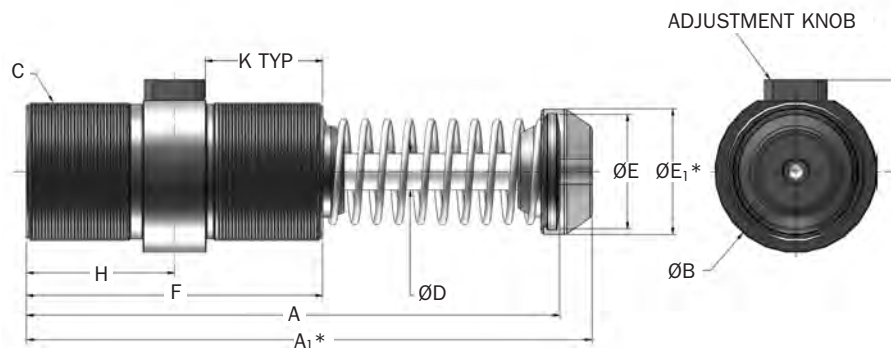

\*Note: A<sub>1</sub> and E<sub>1</sub> apply to urethane striker cap accessory.

Catalog No./Model	(S) Stroke in. (mm)	Optimal Velocity Range in./sec. (m)	(E <sub>T</sub> ) Max. in.-lbs./cycle (Nm/cycle)	(E <sub>T</sub> C) Max. in.-lbs./hour (Nm/h)	(F <sub>p</sub> ) Max. Reaction Force lbs. (N)	Nominal Coil Spring Force		(F <sub>p</sub> ) Max. Propelling Force lbs. (N)	Weight (mass) lbs. (Kg)
						Extended lbs. (N)	Compressed lbs. (N)		
OEM 3.0M x 2	2.0 (50)	12-170 (0,3-4,3)	20,000 (2 300)	3,290,000 (372 000)	15,000 (67 000)	25 (110)	45 (200)	2,700 (12 000)	15.5 (7,0)
OEM 3.0M x 3.5	3.5 (90)	12-170 (0,3-4,3)	35,000 (4 000)	5,770,000 (652 000)	15,000 (67 000)	25 (110)	45 (200)	2,700 (12 000)	20.0 (9,1)
OEM 3.0M x 5	5.0 (125)	12-170 (0,3-4,3)	50,000 (5 700)	8,260,000 (933 000)	15,000 (67 000)	16 (71)	45 (200)	2,700 (12 000)	24.0 (10,9)
OEM 3.0M x 6.5	6.5 (165)	12-170 (0,3-4,3)	65,000 (7 300)	10,750,000 (1 215 000)	15,000 (67 000)	27 (120)	75 (330)	2,700 (12 000)	30.0 (13,6)
OEM 4.0M x 2	2.0 (50)	12-170 (0,3-4,3)	34,000 (3 800)	13,300,000 (1 503 000)	25,000 (111 000)	50 (225)	65 (290)	4,800 (21 000)	33.0 (15,0)
OEM 4.0M x 4	4.0 (100)	12-170 (0,3-4,3)	68,000 (7 700)	16,000,000 (1 808 000)	25,000 (111 000)	35 (155)	65 (290)	4,800 (21 000)	40.0 (18,2)
OEM 4.0M x 6	6.0 (150)	12-170 (0,3-4,3)	102,000 (11 500)	18,600,000 (2 102 000)	25,000 (111 000)	30 (135)	70 (310)	4,800 (21 000)	44.0 (20,0)
Δ OEM 4.0M x 8	8.0 (200)	12-170 (0,3-4,3)	136,000 (15 400)	21,300,000 (2 407 000)	25,000 (111 000)	40 (180)	80 (355)	4,800 (21 000)	66.0 (30,0)
Δ OEM 4.0M x 10	10.0 (250)	12-170 (0,3-4,3)	170,000 (19 200)	24,000,000 (2 712 000)	25,000 (111 000)	30 (135)	80 (355)	4,800 (21 000)	73.0 (33,0)

Note: Δ = Non-standard lead time items, contact ITT Enidine.

Catalog No./Model	A in. (mm)	A <sub>1</sub> in. (mm)	B in. (mm)	C in. (mm)	D in. (mm)	E in. (mm)	E <sub>1</sub> in. (mm)	F in. (mm)	H in. (mm)	J in. (mm)	K in. (mm)
OEM 3.0M x 2	9.66 (245)	10.43 (265)	3.88 (98)	M85 x 2	0.88 (22)	2.75 (69)	3.00 (76)	5.53 (140)	2.77 (70)	2.25 (58)	2.02 (51)
OEM 3.0M x 3.5	12.72 (323)	13.49 (343)	3.88 (98)	M85 x 2	0.88 (22)	2.75 (69)	3.00 (76)	7.06 (179)	3.53 (90)	2.25 (58)	2.78 (71)
OEM 3.0M x 5	15.72 (399)	16.49 (419)	3.88 (98)	M85 x 2	0.88 (22)	2.75 (69)	3.00 (76)	8.50 (217)	4.28 (109)	2.25 (58)	2.78 (71)
OEM 3.0M x 6.5	19.46 (494)	20.23 (514)	3.88 (98)	M85 x 2	0.88 (22)	3.19 (81)	3.19 (81)	10.06 (256)	5.03 (128)	2.25 (58)	2.78 (71)
OEM 4.0M x 2	12.32 (313)	13.20 (335)	5.00 (127)	M115 x 2	1.38 (35)	3.50 (88)	3.75 (95)	8.00 (203)	4.00 (102)	2.89 (74)	3.13 (80)
OEM 4.0M x 4	16.32 (414)	17.20 (436)	5.00 (127)	M115 x 2	1.38 (35)	3.50 (88)	3.75 (95)	10.00 (254)	5.00 (127)	2.89 (74)	4.13 (105)
OEM 4.0M x 6	20.32 (516)	21.20 (538)	5.00 (127)	M115 x 2	1.38 (35)	3.50 (88)	3.75 (95)	12.00 (305)	6.00 (153)	2.89 (74)	4.25 (108)
OEM 4.0M x 8	25.32 (643)	26.20 (665)	5.00 (127)	M115 x 2	1.38 (35)	3.50 (88)	3.75 (95)	14.00 (356)	7.00 (178)	2.89 (74)	4.25 (108)
OEM 4.0M x 10	29.32 (745)	30.20 (767)	5.00 (127)	M115 x 2	1.38 (35)	3.50 (88)	3.75 (95)	16.00 (406)	8.00 (203)	2.89 (74)	4.25 (108)

- Notes: 1. All shock absorbers will function satisfactorily at 5% of their maximum rated energy per cycle. If less than 5%, a smaller model should be specified.  
 2. For mounting accessories, see pages 32.  
 3. Rear flange mounting of OEM 3.0M x 6.5, OEM 4.0M x 8 and OEM 4.0M x 10 models not recommended when mounting horizontally.

# Adjustable Series Hydraulic Shock Absorbers

## OEM Mid-Bore Series

Accessories

OEM 3.0M → OEM 4.0M Series

### Clevis Mount

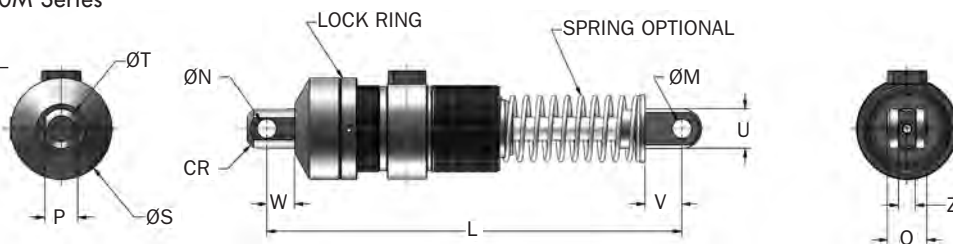

Catalog No./Model	(S) Stroke in. (mm)	L in. (mm)	M in. (mm)	N in. (mm)	P in. (mm)	Q in. (mm)	S in. (mm)	T in. (mm)	U in. (mm)	V in. (mm)	W in. (mm)	Z in. (mm)	CR in. (mm)	Weight (mass) lbs. (Kg)
ΔOEM 3.0M x 2 CM(S)	2.0 (50)	12.81 (325,0)	.751 (19,07) (+0,25/0)	.751 (19,07) (+0,25/0)	1.250 (31,7) (0/-0,3)	1.50 (38,1) (+0,8/-0,8)	3.88 (98,0)	1.50 (38,1)	1.50 (38,1)	1.40 (36,0)	1.06 (26,0)	.640 (16,3) (+0,25/-0,25)	.90 (23,0)	19.1 (8,66)
ΔOEM 3.0M x 3.5 CM(S)	3.5 (90)	15.84 (402,0)	.751 (19,07) (+0,25/0)	.751 (19,07) (+0,25/0)	1.250 (31,7) (0/-0,3)	1.50 (38,1) (+0,8/-0,8)	3.88 (98,0)	1.50 (38,1)	1.50 (38,1)	1.40 (36,0)	1.06 (26,0)	.640 (16,3) (+0,25/-0,25)	.90 (23,0)	23.6 (10,70)
ΔOEM 3.0M x 5 CM(S)	5.0 (125)	18.84 (479,0)	.751 (19,07) (+0,25/0)	.751 (19,07) (+0,25/0)	1.250 (31,7) (0/-0,3)	1.50 (38,1) (+0,8/-0,8)	3.88 (98,0)	1.50 (38,1)	1.50 (38,1)	1.40 (36,0)	1.06 (26,0)	.640 (16,3) (+0,25/-0,25)	.90 (23,0)	27.6 (12,52)
ΔOEM 3.0M x 6.5 CM(S)	6.5 (165)	22.59 (574,0)	.751 (19,07) (+0,25/0)	.751 (19,07) (+0,25/0)	1.250 (31,7) (0/-0,3)	1.50 (38,1) (+0,8/-0,8)	3.88 (98,0)	1.50 (38,1)	1.50 (38,1)	1.40 (36,0)	1.06 (26,0)	.640 (16,3) (+0,25/-0,25)	.90 (23,0)	33.6 (15,24)
ΔOEM 4.0M x 2 CM(S)	2.0 (50)	17.00 (432,0)	1.001 (25,42) (+0,25/0)	1.001 (25,42) (+0,25/0)	1.500 (38,1) (0/-0,3)	3.56 (90,5)	5.00 (127,0)	2.25 (57,2)	2.00 (51,0)	2.00 (51,0)	1.75 (44,0)	1.505 (38,2) (+0,5/0)	1.35 (35,0)	42.4 (19,23)
ΔOEM 4.0M x 4 CM(S)	4.0 (100)	21.00 (533,0)	1.001 (25,42) (+0,25/0)	1.001 (25,42) (+0,25/0)	1.500 (38,1) (0/-0,3)	3.56 (90,5)	5.00 (127,0)	2.25 (57,2)	2.00 (51,0)	2.00 (51,0)	1.75 (44,0)	1.505 (38,2) (+0,5/0)	1.35 (35,0)	49.4 (22,41)
ΔOEM 4.0M x 6 CM(S)	6.0 (150)	25.00 (635,0)	1.001 (25,42) (+0,25/0)	1.001 (25,42) (+0,25/0)	1.500 (38,1) (0/-0,3)	3.56 (90,5)	5.00 (127,0)	2.25 (57,2)	2.00 (51,0)	2.00 (51,0)	1.75 (44,0)	1.505 (38,2) (+0,5/0)	1.35 (35,0)	53.4 (24,22)
ΔOEM 4.0M x 8 CM(S)	8.0 (200)	30.00 (762,0)	1.001 (25,42) (+0,25/0)	1.001 (25,42) (+0,25/0)	1.500 (38,1) (0/-0,3)	3.56 (90,5)	5.00 (127,0)	2.25 (57,2)	2.00 (51,0)	2.00 (51,0)	1.75 (44,0)	1.505 (38,2) (+0,5/0)	1.35 (35,0)	75.4 (34,20)
ΔOEM 4.0M x 10 CM(S)	10.0 (250)	34.00 (864,0)	1.001 (25,42) (+0,25/0)	1.001 (25,42) (+0,25/0)	1.500 (38,1) (0/-0,3)	3.56 (90,5)	5.00 (127,0)	2.25 (57,2)	2.00 (51,0)	2.00 (51,0)	1.75 (44,0)	1.505 (38,2) (+0,5/0)	1.35 (35,0)	82.4 (37,37)

Notes: 1. "S" indicates model is supplied with spring. 2. Δ = Non-standard lead time items, contact ITT Enidine.

### Flange Foot Mount

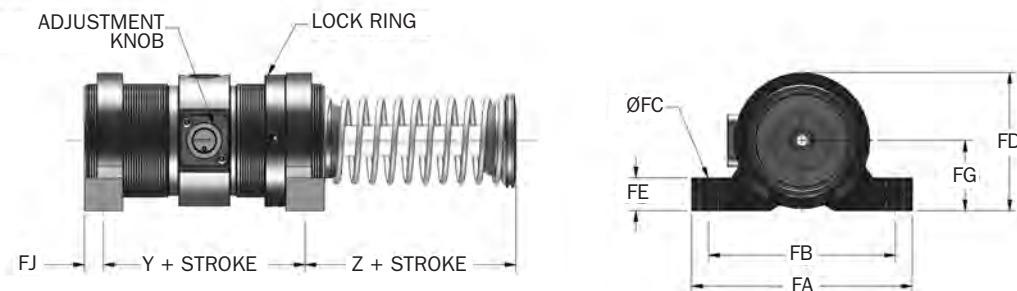

Catalog No./Model	Part Number	Model (Ref)	J in. (mm)	Y in. (mm)	Z in. (mm)	FA in. (mm)	FB in. (mm)	FC in. (mm)	FD in. (mm)	FE in. (mm)	FG in. (mm)	FJ in. (mm)	FK in. (mm)	Bolt Size in. (mm)	Weight (mass) lbs. (kg)	Notes
FM M85 x 2	2F3330	OEM 3.0M	2.25	3.19	2.32	6.50	5.50	.53	4.06	1.00	2.06	0.57	1.13	1/2	6.9	1
		OEM 3.0M	(58)	(81,0)	(59,0)	(165,0)	(139,7)	(13,5)	(103,0)	(25,4)	(52,3)	(14,1)	(28,7)	(M12)	(1 984)	1
FM M115 x 2	2F3720	OEM 4.0M	2.82	7.50	1.44	8.00	6.50	.65	5.88	1.50	3.13	0.63	2.50	5/8	8.6	2
		OEM 4.0M	(74)	(190,5)	(37,0)	(203,2)	(165,0)	(16,8)	(149,4)	(38,0)	(79,5)	(16,0)	(50,8)	(M16)	(3 900)	2

Notes:  
 1. OEM 3.0M x 6,5, Z dimension is 77,7mm.  
 2. OEM 4.0M x 8 and 4.0M x 10M, Z dimension is 62,0mm.  
 3. For rear foot mount, dimension FJ is 22,4mm.

Adjustable Series

Stop Collar (SC)

(LR)OEM 3/4 → (LR)OEM 2.0M



Catalog No./Model	Part Number	Model (Ref)	CA in. (mm)	CB in. (mm)	CD in. (mm)	Weight (mass) oz. (g)
Δ SC 1 3/4 - 12	8KE2940	(LR)OEMXT 3/4	1.94 (49,0)	1.94 (49,0)	2.22 (56,5)	12.0 (340)
Δ SC M2 1/2 - 12*						
Δ SC 2 1/2 - 12 x 2	8KE3010	(LR)OEMXT 1 1/8 x 2 & 4	2.47 (63,0)	2.54 (65,0)	3.00 (76,0)	23.0 (652)
Δ SC M2 1/2 - 12 x 2						
Δ SC 2 1/2 - 12 x 6	8KE3012	OEMXT 1 1/8 x 6	3.66 (93,0)	2.54 (65,0)	3.00 (76,0)	33.0 (936)
Δ SC M42 x 1.5 x 1	8K2940	(LR)OEMXT 1.5M x 1	2.44 (62,0)	1.94 (49,0)	2.22 (56,0)	14.0 (397)
Δ SC M42 x 1.5 x 2	8K2941	(LR)OEMXT 1.5M x 2	2.94 (75,0)	1.94 (49,0)	2.22 (56,0)	19.0 (539)
Δ SC M42 x 1.5 x 3	8K2942	OEMXT 1.5M x 3	3.44 (87,0)	1.94 (49,0)	2.22 (56,0)	23.0 (652)
Δ SC M64 x 2 x 2	8K3010 M93010057	(LR)OEMXT 2.0M x 2	3.50 (89,0)	2.54 (65,0)	3.00 (76,0)	33.0 (936)
Δ SC M64 x 2 x 4	8K3011 M93011057	OEMXT 2.0M x 4	4.50 (114,0)	2.54 (65,0)	3.00 (76,0)	42.0 (1191)
Δ SC M64 x 2 x 6	8K3012 M93012057	OEMXT 2.0M x 6	5.63 (143,0)	2.54 (65,0)	3.00 (76,0)	52.0 (1475)

Notes: 1. \* Do not use with urethane striker cap. 2. Δ = Non-standard lead time items, contact ITT Enidine.

Lock Ring (LR)

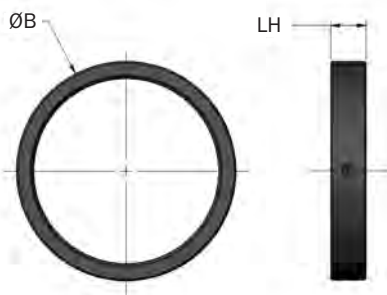

Catalog No./Model	Part Number	Model (Ref)	B in. (mm)	LH in. (mm)	Weight (mass) oz. (g)
LR 1 3/4 - 12	F8E2940049	(LR)OEMXT 3/4	2.00 (50,8)	.38 (9,5)	2.0 (57)
LR 2 1/2 - 12	F8E3010049	(LR)OEMXT 1 1/8	2.88 (73,0)	.38 (9,5)	3.0 (85)
LR M42 x 1.5	F82940049	(LR)OEMXT 1.5M	2.00 (50,8)	.38 (9,6)	3.0 (85)
LR M64 x 2	F83010049	(LR)OEMXT 2.0M	2.88 (73,0)	.50 (12,7)	4.0 (114)
LR M85 x 2	F83330049	(LR)OEM 3.0M	3.88 (98,2)	.63 (16,0)	8.0 (226)
LR M115 x 2	F83720049	(LR)OEM 4.0M	5.00 (126,7)	.88 (22,4)	14.0 (397)

Square Flange (SF)

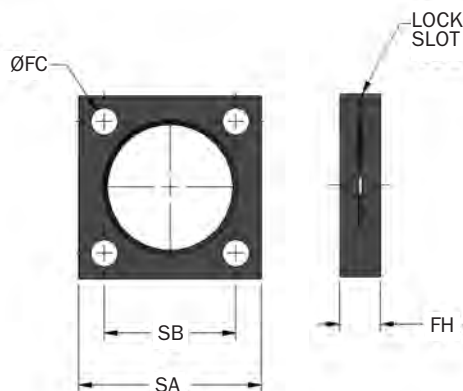

Catalog No./Model	Part Number	Model (Ref)	FC in. (mm)	FH in. (mm)	SA in. (mm)	SB in. (mm)	Bolt Size in. (mm)	Weight (mass) oz. (g)
SF 1 3/4 - 12	M4E2940129	(LR)OEMXT 3/4	.34 (8,6)	.50 (12,7)	2.25 (57,2)	1.63 (41,4)	3/16 (M8)	5.0 (140)
SF 2 1/2 - 12	M4E3010129	(LR)OEMXT 1 1/8	.41 (10,4)	.62 (15,7)	3.50 (88,9)	2.75 (69,9)	3/8 (M10)	20.0 (570)
SF M42 x 1.5	M42940129	(LR)OEMXT 1.5M	.34 (8,6)	.50 (12,7)	2.25 (57,2)	1.63 (41,4)	3/16 (M8)	5.0 (140)
SF M64 x 2	M43010141	(LR)OEMXT 2.0M	.41 (10,4)	.62 (15,7)	3.50 (88,9)	2.75 (69,9)	3/8 (M10)	20.0 (570)
SF M85 x 2	M43330141	OEM 3.0M	.53 (13,5)	.75 (19,0)	4.00 (101,6)	3.00 (76,2)	1/2 (M13)	24.0 (680)
SF M115 x 2	M43720141	OEM 4.0M	.65 (16,5)	1.00 (25,4)	5.50 (139,7)	4.38 (111,3)	3/8 (M16)	56.0 (1590)

**Rectangular Flange (RF)**

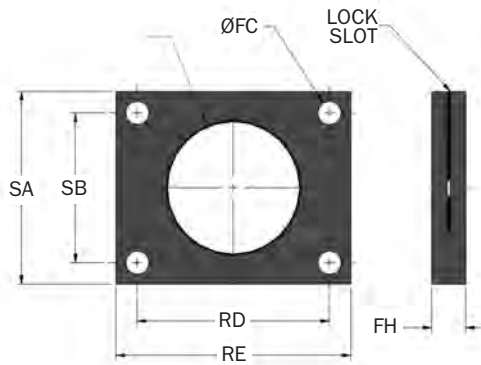

Catalog No./ Model	Part Number	Model (Ref)	FC in. (mm)	FH in. (mm)	RD in. (mm)	RE in. (mm)	SA in. (mm)	SB in. (mm)	Bolt Size in. (mm)	Weight (mass) oz. (g)
RF 1 3/4 -12	M5E2940129	(LR)OEMXT 3/4	.34 (8,6)	.50 (12,7)	2.38 (60,5)	3.00 (76,2)	2.25 (57,2)	1.63 (41,4)	5/16 (M8)	9.0 (260)
RF M42 x 1.5	M52940129	(LR)OEMXT 1.5M	.34 (8,6)	.50 (12,7)	2.38 (60,5)	3.00 (76,2)	2.25 (57,2)	1.63 (41,4)	5/16 (M8)	9.0 (260)
RF M85 x 2	M53330129	OEM 3.0M	.53 (13,5)	.75 (19,1)	4.00 (101,6)	5.00 (127,0)	4.00 (101,6)	3.00 (76,2)	1/2 (M13)	37.0 (1 040)

**Stop Bar Kit**

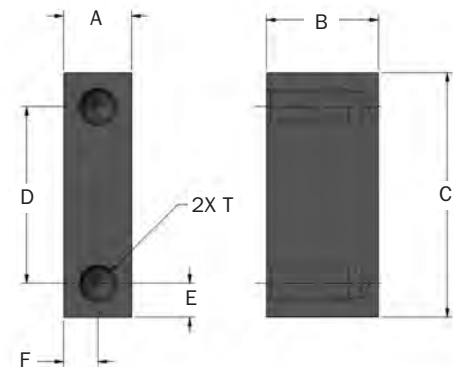

Kit Part Number	Model (Ref)	A in. (mm)	B in. (mm)	C in. (mm)	D in. (mm)	E in. (mm)	F in. (mm)	T in. (mm)	Bolt Size in. (mm)	Weight (mass) oz. (g)
ΔT58706300	OEMXT 3/4	.63 (16,0)	1.03 (26,2)	2.25 (57,2)	1.63 (41,4)	.31 (7,9)	.32 (8,1)	5/16 - 24 UNF x 3/4 DEEP	5/16	6.1 (173)
ΔT52940300		1.42 (36,1)	3.50 (88,9)	2.75 (69,9)	.38 (9,7)					
ΔT58650300	OEMXT 1 1/8	.63 (12,7)	1.42 (36,1)	3.50 (88,9)	2.75 (69,9)	.38 (9,7)	.32 (8,1)	3/8 - 24 UNF x 3/4 DEEP	3/8	10.5 (298)
ΔT53010300										

Notes: 1. Kit includes 2 Stop Bars, Rectangular Flange for OEM 3/4 and 1.5, Square Flange for 1 1/8 and 2.0 and Lock Ring.  
2. Δ = Non-standard lead time items, contact ITT Enidine.

**Urethane Striker Cap (UC)**

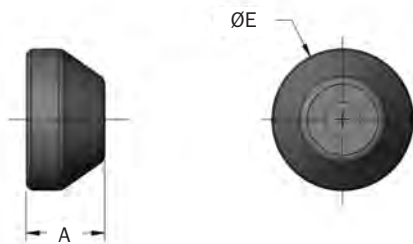

Catalog No./ Model	Part Number	Model (Ref)	A in. (mm)	E1 in. (mm)	Weight (mass) oz. (g)
UC 2940	C92940079	(LR)OEMXT 3/4	.97 (24,5)	1.75 (44,5)	0.5 (14)
UC 3010	C93010079	(LR)OEMXT 1 1/8	.95 (24,1)	2.25 (57,0)	0.8 (23)
UC 2940	C92940079	(LR)OEMXT 1.5M	.97 (24,5)	1.75 (44,5)	0.5 (14)
UC 3010	C93010079	(LR)OEMXT 2.0M	.95 (24,1)	2.25 (57,0)	0.8 (23)
UC 3330	C93330079	OEM 3.0M	1.22 (31,4)	3.00 (76,0)	3.0 (85)
UC 3720	C93720079	OEM 4.0M	1.47 (37,5)	3.75 (95,0)	6.0 (170)

Notes: For complete shock absorber dimension with urethane striker cap, refer to engineering data, pages 27-31.

**Stop Collar With Flange (SCF)**

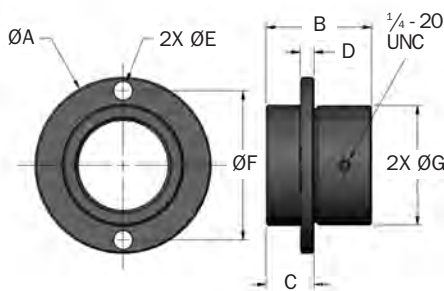

Catalog No./ Model	Part Number	Model (Ref)	A in. (mm)	B in. (mm)	C ±.002 in. (mm)	D in. (mm)	E in. (mm)	F in. (mm)	G in. (mm)	Bolt Size in. (mm)	Weight (mass) oz. (g)
ΔSCF 1 3/4 -12	M98640300	OEMXT 3/4	3.25 (83)	1.94 (49,3)	.88 (22,4)	.25 (6,4)	.34 (8,6)	2.75 (70)	2.20 (56)	5/16 (8)	20.5 (638)
ΔSCF 2 1/2 -12	M98650300	OEMXT 1 1/8	4.25 (108)	2.47 (63)	1.00 (25,4)	.38 (9,7)	.34 (8,6)	3.50 (89)	2.95 (75)	5/16 (8)	39.8 (1 238)

Notes: 1. Locking set screw feature provided as standard. 2. Δ = Non-standard lead time items, contact ITT Enidine.

# Adjustable Series Hydraulic Shock Absorbers

## ECO OEM/OEMXT/OEM Large Bore Series

### Adjustment Techniques

After properly sizing the shock absorber, the useable range of adjustment settings for the application can be determined:

1. Locate the intersection point of the application's impact velocity and the selected model graph line.
2. The intersection is the **maximum** adjustment setting to be used. Adjustments exceeding this maximum suggested setting could overload the shock absorber.
3. The useable adjustment setting range is from the 0 setting to the **maximum** adjustment setting as determined in step 2.

#### Example: OEM 1.25 x 1

1. Impact Velocity: 40 in./sec.
2. Intersection Point: Adjustment Setting 5
3. Useable Adjustment: Setting Range 0 to 5

#### Example: (LR)OEMXT 1 1/8 x 2

1. Impact Velocity: 20 in./sec.
2. Intersection Point: Adjustment Setting 3
3. Useable Adjustment: Setting Range 0 to 3

### Useable Adjustment Setting Range

Position 0 provides minimum damping force.  
Position 8 provides maximum damping force.

#### OEMXT Large

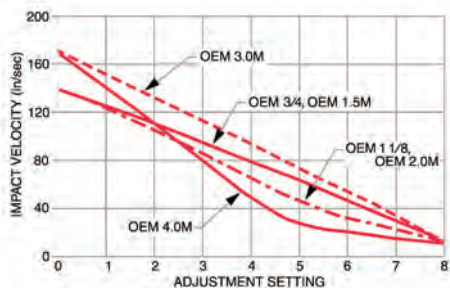

180° adjustment with setscrew locking. OEMXT 3.0M - OEM 4.0M



360° adjustment with setscrew locking. OEMXT 3/4 and OEMXT 1 1/8, OEMXT 1.5M and OEMXT 2.0M

#### (LR)OEMXT Large

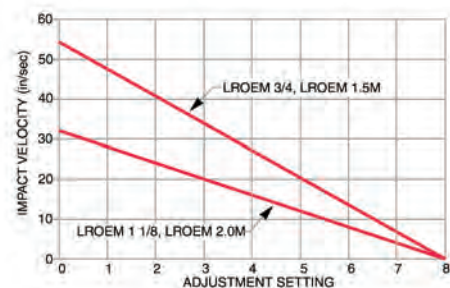

360° adjustment with setscrew locking (LR)OEMXT 3/4 and (LR)OEMXT 1 1/8, (LR)OEMXT 1.5M and (LR)OEMXT 2.0M

#### ECO OEM Small Series

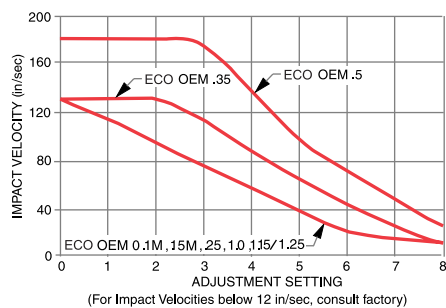

180° adjustment with setscrew locking ECO OEM 0.1M - ECO OEM .5



360° adjustment with setscrew locking ECO OEM 1.0

#### ECO (LR)OEM Small Series

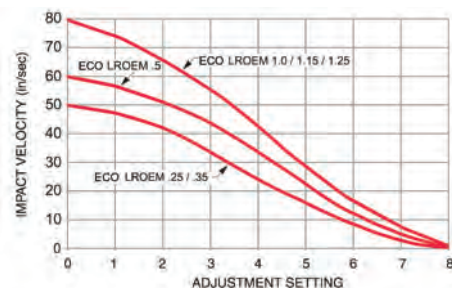

180° adjustment with setscrew locking ECO (LR)OEM 0.15M - (LR)OEM .5



360° adjustment with setscrew locking ECO (LR)OEM 1.0

## Typical Applications

Adjustable Series



*Automotive Manufacturing Applications*



*Bottling Applications*



*Automated Applications*



ITT Enidine non-adjustable micro-bore hydraulic shock absorbers can accommodate varying energy conditions. This family of tamperproof shock absorbers provides consistent performance, cycle after cycle. Non-adjustable models are designed to absorb maximum energy within a compact envelope size.

The **TK Series** is a versatile, miniature design which provides effective, reliable deceleration and vibration control for light loads. Models can accommodate a wide range of operating conditions.

The ITT Enidine **STH Series** offers the highest energy absorption capacity relative to its size. These custom-orificed shock absorbers are designed to meet exact application requirements. STH Series shock absorbers are available in fully threaded cylinder bodies, providing flexibility in mounting configurations.

## Features and Benefits

- Extensive non-adjustable product line offers flexibility in both size and energy absorption capacity to fulfill a wide range of application requirements.
- Tamperproof design ensures repeatable performance.
- Special materials and finishes can be designed to meet specific customer requirements.
- Incorporating optional fluids and seal packages can expand the standard operating temperature range from (15°F to 180°F) to (-30°F to 210°F).
- Threaded cylinders provide mounting flexibility and increase surface area for improved heat dissipation.
- A select variety of surface finishes maintains original quality appearance and provides the longest corrosion resistance protection.
- ISO quality standards result in reliable, long-life operation.



# Non-Adjustable Series Hydraulic Shock Absorbers

TK, STH Micro-Bore Series

Overview

## ITT Enidine Non-Adjustable Single-Orifice Shock Absorbers

Non-Adjustable Series

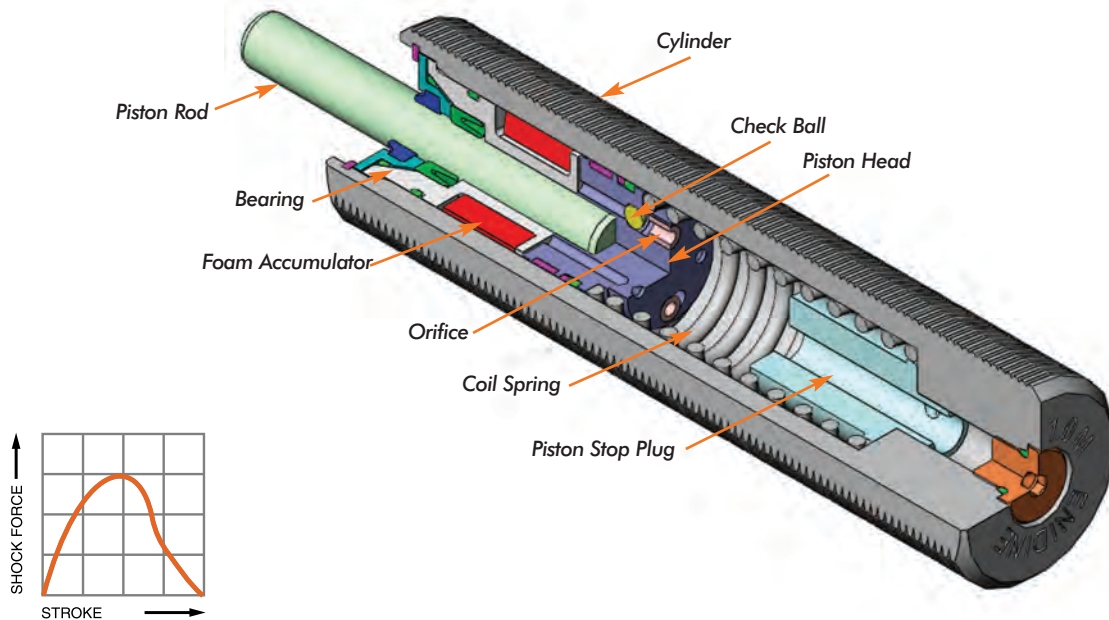

**Constant orifice area damping** (dashpot) provides the largest shock force at the beginning of the stroke when impact velocity is highest. These shock absorbers provide high-energy absorption in a small, economical design.

The internal structure of a single orifice shock absorber is shown above. When a force is applied to the piston rod, the check ball is seated and the valve remains closed. Oil is forced through the orifice, creating internal pressure allowing smooth, controlled deceleration of the moving load. When the load is removed, the compressed coil spring moves to reposition the piston head, the check ball unseats, opening the valve that permits rapid return of the piston head rod to the original extended position.

The closed cellular foam accumulator is compressed by the oil during the stroke, compensating for fluid displaced by the piston rod during compression. Without the fluid displacement volume provided by the foam accumulator, the closed system would be hydraulically locked.

Single-orifice shock absorbers provide constant orifice area (dashpot) damping.

TK 6M, TK 8 Series

### Standard

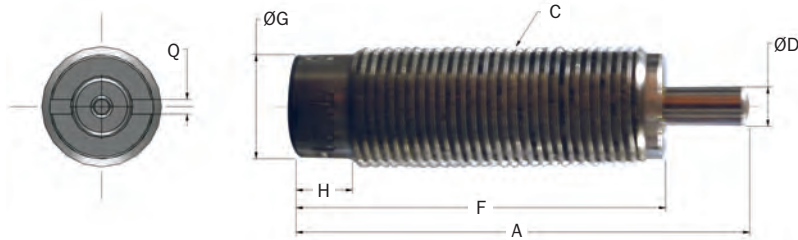

Catalog No./ Model	Bore Size in. (mm)	(S) Stroke in. (mm)	(E <sub>T</sub> ) Max. in.-lbs./cycle (Nm/c)	(E <sub>T</sub> C) Max. in.-lbs./hour (Nm/h)	(F <sub>p</sub> ) Max. Shock Force lbs. (N)	Nominal Coil Spring Force		Weight (mass) oz. (g)
						Extended lbs. (N)	Compressed lbs. (N)	
TK 6M	.16 (4,2)	.16 (4,0)	9 (1,0)	31,863 (3 600)	81 (360)	0.2 (1,0)	0.8 (3,5)	.14 (4)
TK 8M	.16 (4,2)	.16 (4,0)	9 (1,0)	42,480 (4 800)	81 (360)	0.2 (1,0)	0.8 (3,5)	.2 (6)

Catalog No./ Model	Damping Constant	A in. (mm)	C in. (mm)	ØD in. (mm)	F in. (mm)	G in. (mm)	H in. (mm)	Q in. (mm)
TK 6M	-1, -2, -3	1.14 (29,0)	M6 x 0,5	.08 (2,0)	1.0 (25,0)	.20 (5,0)	.16 (4,0)	.04 (1,0)
TK 8M	-1, -2, -3	1.14 (29,0)	M8 x 1,0	.08 (2,0)	1.0 (25,0)	.25 (6,4)	.16 (4,0)	.04 (1,0)

Notes: 1. Dash numbers are non-standard lead time items, contact ITT Enidine.  
 2. A positive stop is required to prevent the internal damage of the TK 6 and TK 8 shock absorbers.

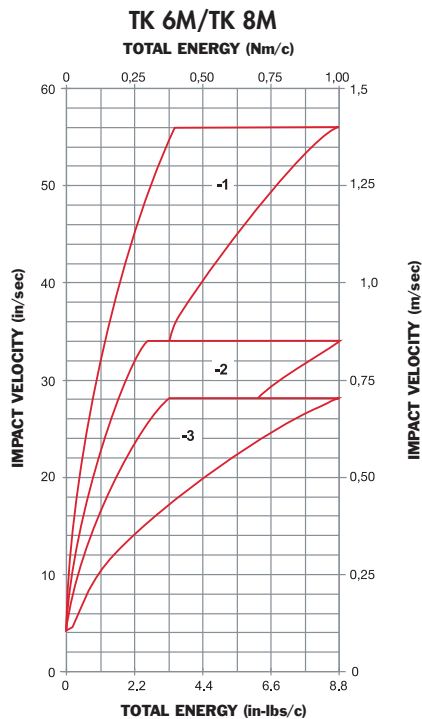

# Non-Adjustable Series Hydraulic Shock Absorbers

## TK Micro-Bore Series

### Technical Data

#### TK 10M Series Standard

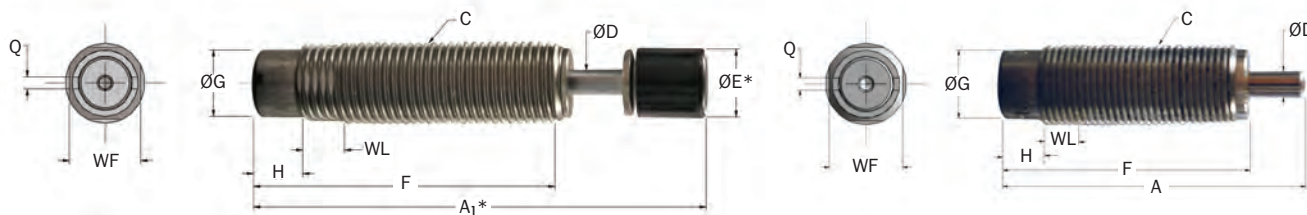

\*Note: A<sub>1</sub> and E apply to button models and urethane striker cap accessory.

Catalog No./ Model	(S) Stroke in. (mm)	(E <sub>T</sub> ) Max. in.-lbs./cycle (Nm/c)	(E <sub>T</sub> C) Max. in.-lbs./hour (Nm/h)	(F <sub>P</sub> ) Max. Shock Force lbs. (N)	Nominal Coil Spring Force		(F <sub>D</sub> ) Max. Propelling Force lbs. (N)	Weight (mass) oz. (g)
					Extended lbs. (N)	Compressed lbs. (N)		
TK 10M (B)	.25 (6,4)	50 (6,0)	115,000 (13 000)	315 (1 400)	0.3 (1,5)	2.2 (10,0)	-	.6 (17)

Catalog No./ Model	Damping Constant	A in. (mm)	A <sub>1</sub> in. (mm)	C in. (mm)	D in. (mm)	ØE in. (mm)	F in. (mm)	G in. (mm)	H in. (mm)	Q in. (mm)	WF in. (mm)	WL in. (mm)	Stroke (S) in. (mm)
TK 10M (B)	-1 to -9	1.75 (44,6)	2.14 (54,4)	M10 x 1,0 (3,1)	.12 (3,1)	.35 (8,5)	1.50 (38,0)	.33 (8,3)	.20 (5,0)	.06 (1,5)	.35 (9,0)	.16 (4,0)	0.25 (6,4)

Note: Dash numbers in page color are non-standard lead time items, contact ITT Enidine.

#### TK 21M Series Standard

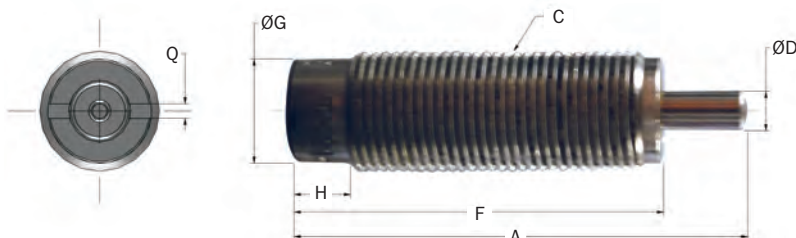

\*Note: A<sub>1</sub> and E apply to button models and urethane striker cap accessory.

Catalog No./ Model	(S) Stroke in. (mm)	(E <sub>T</sub> ) Max. in.-lbs./cycle (Nm/c)	(E <sub>T</sub> C) Max. in.-lbs./hour (Nm/h)	(F <sub>P</sub> ) Max. Shock Force lbs. (N)	Nominal Coil Spring Force		(F <sub>D</sub> ) Max. Propelling Force lbs. (N)	Weight (mass) oz. (g)
					Extended lbs. (N)	Compressed lbs. (N)		
TK 21	.25 (6,4)	20 (2,2)	36,000 (4 100)	160 (700)	0.65 (2,9)	1.13 (5,0)	20 (89)	.4 (12)

Catalog No./ Model	Damping Constant	A in. (mm)	C in. (mm)	D in. (mm)	F in. (mm)	G in. (mm)	H in. (mm)	Q in. (mm)
TK 21	-1, -2, -3	1.39 (35,4)	3/8 - 32 UNEF (9,5)	.12 (3,1)	1.13 (28,7)	.32 (8,2)	.17 (4,4)	.05 (1,2)

Note: A positive stop is required to prevent the bottoming of the TK 21 shock absorber.

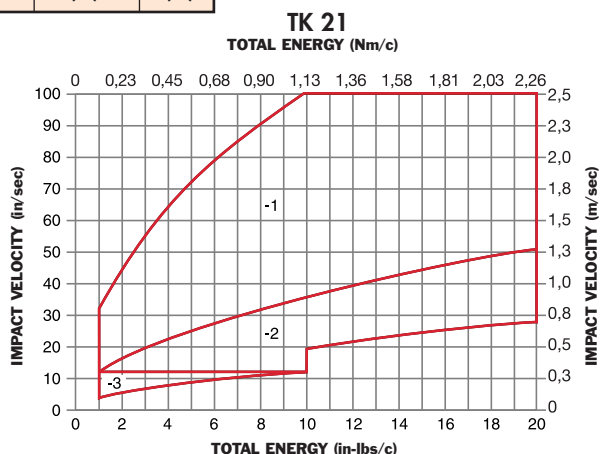
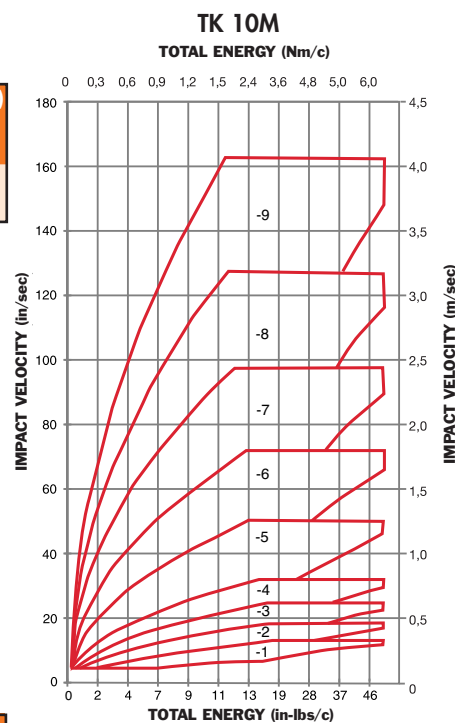

STH .25M → STH 1.5M x 2 Series

### Custom Orificed Products

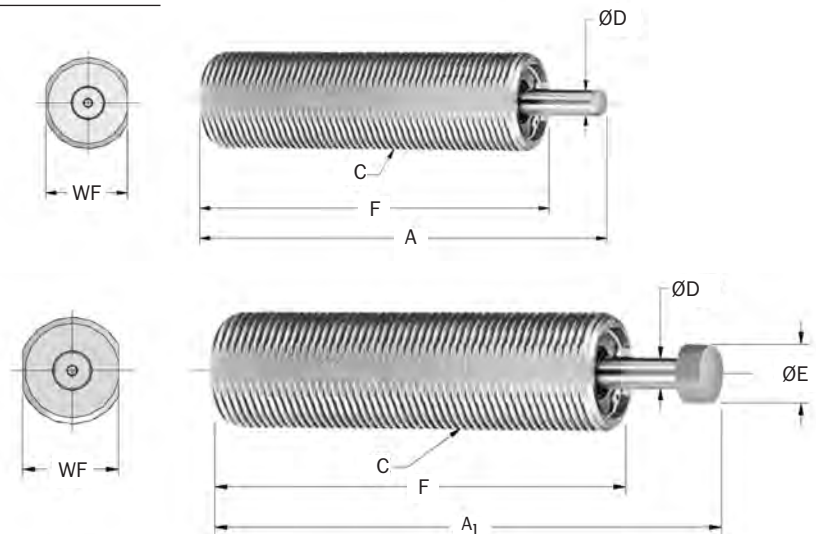

Catalog No./ Model	(S) Stroke in. (mm)	(E <sub>T</sub> ) Max. in.-lbs./cycle (Nm/c)	(E <sub>T</sub> -C) Max. in.-lbs./hour (Nm/h)	(F <sub>P</sub> ) Max. Shock Force lbs. (N)	Nominal Coil Spring Force		Model Weight lbs. (g)
					Extended lbs. (N)	Compressed lbs. (N)	
Δ STH .25M	0.25 (6,0)	100 (11)	39,000 (4 420)	615 (2 730)	2.5 (11)	4.0 (18)	2.8 oz. (79)
Δ STH .5M	0.50 (12,5)	585 (65)	390,000 (44 200)	1,800 (8 000)	4.0 (18)	7.0 (31)	7.7 oz. (218)
Δ STH .75M	0.75 (19,0)	2,180 (245)	780,000 (88 400)	4,400 (19 600)	8.0 (35)	20.0 (90)	1.1 (500)
Δ STH 1.0M	1.00 (25,0)	4,400 (500)	1,300,000 (147 000)	6,700 (29 800)	22.0 (98)	53.0 (235)	1.6 (726)
Δ STH 1.0M x 2	2.00 (50,0)	8,800 (1 000)	2,100,000 (235 000)	6,700 (29 800)	15.0 (66)	30.0 (133)	1.9 (862)
Δ STH 1.5M x 1	1.00 (25,0)	10,200 (1 150)	2,200,000 (250 000)	14,600 (65 000)	20.0 (90)	51.0 (227)	3.1 (1 400)
Δ STH 1.5M x 2	2.00 (50,0)	20,400 (2 300)	3,200,000 (360 000)	14,600 (65 000)	12.5 (56)	51.0 (227)	4.0 (1 800)

- Notes: 1. Custom orificed application data needed.  
 2. All shock absorbers will function at 5% of their rated energy per cycle. If less than 5%, a smaller model should be specified.  
 3. Enidine recommends a positive stop to prevent bottoming of the shock absorber.  
 4. Δ = Non-standard lead time items, contact ITT Enidine.

Catalog No./ Model	A in. (mm)	A <sub>1</sub> in. (mm)	C in. (mm)	D in. (mm)	E in. (mm)	F in. (mm)	WF in. (mm)
STH .25M	-	2.81 (71,0)	M14 X 1.0	.19 (4,8)	.50 (12,7)	2.00 (51,0)	.50 (13,0)
	-	-	M14 x 1,0	-	-	-	-
STH .5M	-	3.50 (89,0)	M22 X 1.5	.22 (5,6)	.38 (9,5)	2.70 (68,5)	.88 (20,0)
	-	-	M22 x 1,5	-	-	-	-
STH .75M	-	5.13 (130,0)	M30 X 2.0	.31 (8,0)	.56 (14,3)	4.06 (103,0)	1.13 (27,0)
	-	-	M30 x 2,0	-	-	-	-
STH 1.0M	-	6.70 (170,0)	M36 X 1.5	.38 (9,5)	.69 (17,5)	5.38 (136,5)	1.25 (32,0)
	-	-	M36 x 1,5	-	-	-	-
STH 1.0M x 2	-	9.38 (238,2)	M36 X 1.5	.38 (9,5)	.69 (17,5)	7.02 (178,3)	1.25 (32,0)
	-	-	M36 x 1,5	-	-	-	-
STH 1.5M x 1	7.09 (180,0)	-	M45 X 1.5	.63 (16,0)	-	6.06 (154,0)	1.63 (42,0)
	-	-	M45 x 1,5	-	-	-	-
STH 1.5M x 2	10.63 (270,0)	-	M45 X 1.5	.63 (16,0)	-	8.62 (219,0)	1.63 (42,0)
	-	-	M45 x 1,5	-	-	-	-

# Non-Adjustable Series Hydraulic Shock Absorbers

TK, STH Micro-Bore Series

## Accessories

TK 10 → STH 1.5M x 2 Series

### Jam Nut (JN)

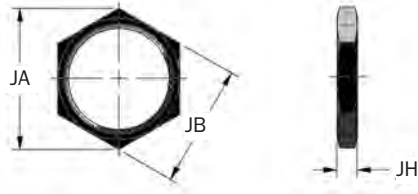

Catalog No./Model	Part Number	Model (Ref)	JA in. (mm)	JB in. (mm)	JH in. (mm)	Weight (mass) oz. (g)
JN 3/8 - 32	J14421034	TK 21	.58 (14,7)	.50 (12,7)	.09 (2,2)	0.1 (2,8)
JN M10 x 1	J24421035	TK10M/TK21M	0.59 (15,0)	0.51 (13,0)	.13 (3,2)	0.1 (2,8)
JN M14 x 1	J24950035	STH .25M	.77 (19,7)	.67 (17,0)	.16 (4,0)	0.2 (3)
JN M22 x 1.5	J26402035	STH .5M	1.24 (31,5)	1.06 (27,0)	.22 (5,5)	0.5 (12)
JN M30 x 2	J230583035	STH .75M	1.63 (41,6)	1.42 (36,0)	.27 (7,0)	0.9 (26)
JN M36 x 1.5	J23164035	STH 1.0M	1.86 (47,6)	1.61 (41,0)	.25 (6,4)	0.9 (26)
JN M36 x 1.5	J23164035	STH 1.0 x 2M	1.86 (47,6)	1.61 (41,0)	.25 (6,4)	0.9 (26)

### Lock Ring (LR)

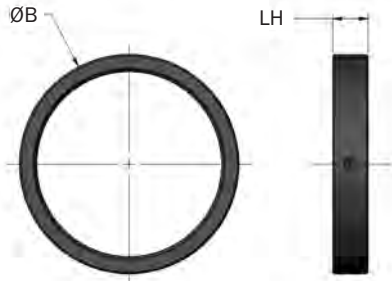

Catalog No./Model	Part Number	Model (Ref)	B in. (mm)	LH in. (mm)	Weight (mass) oz. (g)
LR M45 x 1.5	F88637049	STH 1.5 Series	2.25 (57,2)	.38 (9,5)	2.0 (75)

### Square Flange (SF)

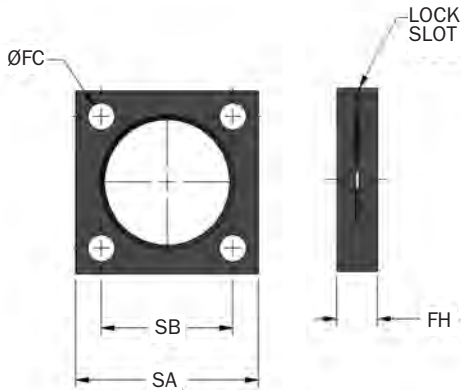

Catalog No.	Part Number	Model (Ref)	FC in. (mm)	FH in. (mm)	SA in. (mm)	SB in. (mm)	Bolt Size in. (mm)	Weight (mass) oz. (g)
SF M45 X 1.5	M48637129	STH 1.5 Series	.34 (8,6)	.50 (12,7)	2.25 (57,2)	1.63 (41,3)	5/16 (M8)	5 (142)

### Side Load Adapter (SLA)

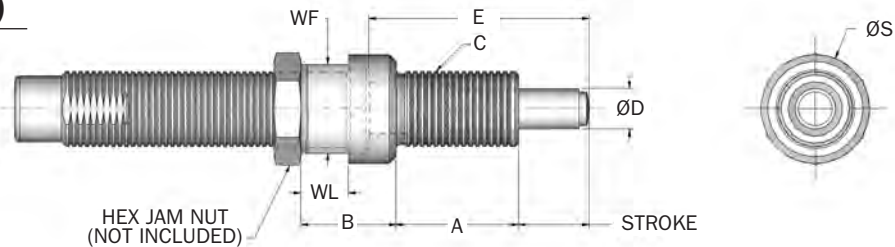

Catalog No./Model	Part Number	Model (Ref)	Stroke in. (mm)	A in. (mm)	B in. (mm)	C in. (mm)	D in. (mm)	E in. (mm)	S in. (mm)	WF in. (mm)	WL in. (mm)
SLA 3/8 - 32 x .25	SLA 33843	TK 21	.26 (6,6)	.47 (12)	.43 (11)	3/8 - 32 UNEF	.20 (5,0)	.85 (21,6)	.51 (13,0)	.44 (11,0)	.16 (4,0)
SLA 10 MF	SLA 33457	TK 10M/TK 21M	.27 (6,9)	.47 (12)	.43 (11)	M10 x 1 M10 x 1	.20 (5,0)	.85 (21,6)	.51 (13,0)	.43 (11,0)	.16 (4,0)

Notes: 1. Maximum sideload angle is 30°. 2. Dash number in page color are non-standard lead time items, contact ITT Enidine.

Non-Adjustable Series

TK 10 → STH 1.5M x 2 Series

### Rectangular Flange (RF)

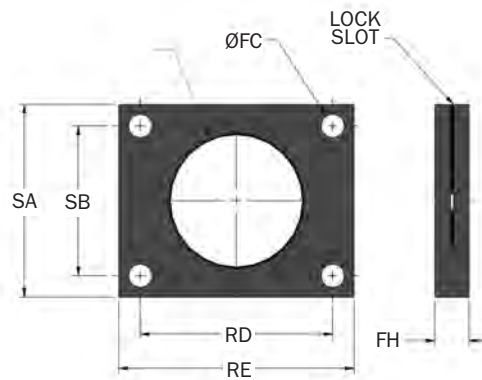

Catalog No./ Model	Part Number	Model (Ref)	A in. (mm)	FC in. (mm)	FH in. (mm)	RD in. (mm)	RE in. (mm)	SA in. (mm)	SB in. (mm)	Bolt Size in. (mm)	Wt. (mass) oz. (g)
RF M45 x 1.5	M58637053	STH 1.5 Series	M45 x 1.5	.34 (8,6)	.50 (12,7)	2.38 (60,5)	3.00 (76,2)	2.25 (57,2)	1.63 (41,3)	<sup>5</sup> / <sub>16</sub> (M8)	9 (142)

### Universal Retaining Flange (UF)

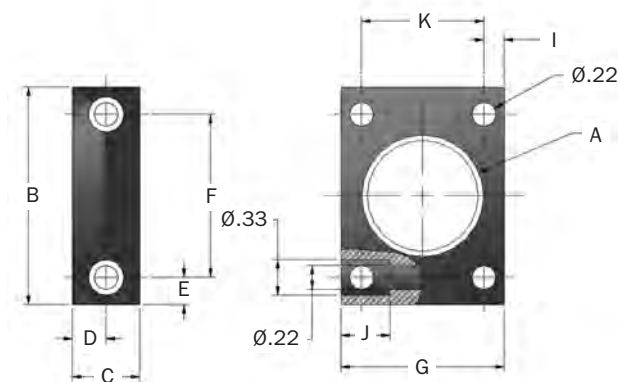

Catalog No./ Model	Part Number	Model (Ref)	A in. (mm)	B in. (mm)	C in. (mm)	D in. (mm)	E in. (mm)	F in. (mm)	G in. (mm)	H in. (mm)	J in. (mm)
UF M10 x 1	U16363189	TK 10M(B)/TK21M	M10 x 1	1.50 (38,0)	.47 (12,0)	.24 (6,0)	.25 (6,25)	1.00 (25,5)	1.00 (25)	.50 (12,5)	.20 (5)
UF <sup>3</sup> / <sub>8</sub> - 32	U19070095	TK21	<sup>3</sup> / <sub>8</sub> - 32 UNF	1.50	.56	.28	.25	1.00	1.00	.50	.20

## Typical Applications

Non-Adjustable Series



Packaging



Medical Devices



High Speed Automation



ITT Enidine's **New ECO Series** non-adjustable hydraulic shock absorbers can accommodate varying energy conditions. This family of tamperproof shock absorbers provides consistent performance, cycle after cycle. Non-adjustable models are designed to absorb maximum energy within a compact envelope size.

The **ECO Series** was designed using materials and fluids that are safe for our environment. Models can accommodate a wide range of operating conditions with varying masses or propelling forces. The **ECO Series** offers a flexible design to accommodate a wide variety of application parameters. Whether your application has a low velocity/high drive force or high velocity/low drive force condition, the **New ECO Series** will deliver the performance that you have come to expect.

## Features and Benefits

- **Extensive non-adjustable product line** offers flexibility in both size and energy absorption capacity to fulfill a wide range of application requirements.
- **Environmentally friendly materials:**
  - RoHS Compliant materials
  - Bio-degradable hydraulic oil
  - Copper-Free design
  - Recyclable packaging materials
- **Introducing our new Enicote II surface finish:**
  - RoHS Compliant
  - Rated at 350 hours salt spray corrosion protection
- **Jam Nut included** with every shock absorber.
- **ISO quality standards** result in reliable, long-life operation.
- **Tamperproof design** ensures repeatable performance.
- **Threaded cylinders provide mounting flexibility** and increase surface area for improved heat dissipation.
- **Wrench flats** promote ease of mounting
- **Capability to mount into pressure chambers**
- **Integrated positive stopping capabilities** up to 100 psi (7 bar).
- **Special materials and finishes** can be designed to meet specific customer requirements
  - Optional fluids and seal packages can expand the standard operating temperature range from (15°F to 180°F) to (-30°F to 210°F)
  - Food grade options available
- **Custom orificed (CBECO)** can be engineered to meet specific application requirements or emergency impact only requirements.



# Non-Adjustable Series Hydraulic Shock Absorbers

## ECO Series

### Overview

#### ITT Enidine Non-Adjustable Multiple Orifice Shock Absorbers

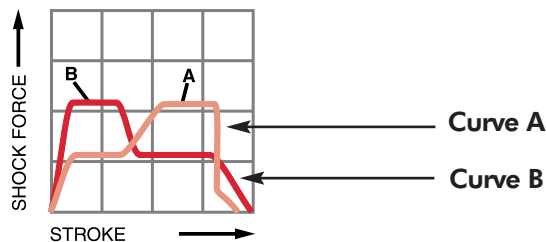
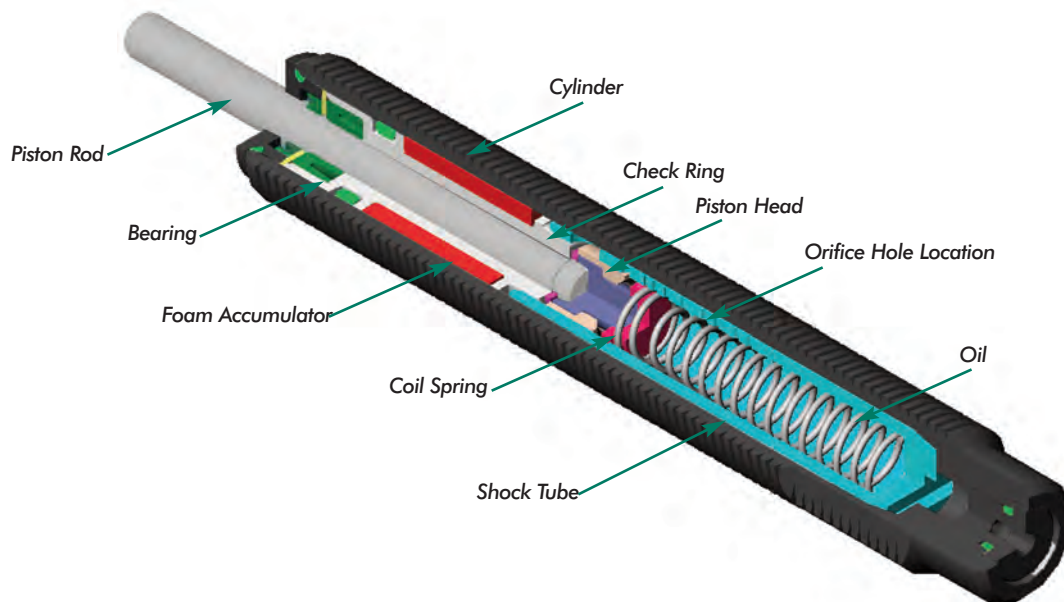

**Self-compensating damping** maintains acceptable deceleration with conventional type damping characteristics. Self-compensating shock absorbers operate over a wide range of weights and velocities. These shock absorbers are well suited for high drive force, low velocity applications, and where energy conditions may change. **Curve A** shows the *shock force vs. stroke* curve of a self-compensating shock absorber impacted with a low velocity and high drive force. **Curve B** shows the *shock force vs. stroke* curve of a self-compensating shock absorber impacted with a high velocity and low drive force.

The design of a multi-orifice shock absorber features a double cylinder arrangement with space between the concentric shock tube and cylinder, and a series of orifice holes drilled down the length of the shock tube wall.

During piston movement, the check ring is seated and oil is forced through the orifices in the shock tube wall, into the closed cellular foam accumulator and behind the piston head.

As the piston head moves it closes off orifice holes, thus reducing the available orifice area in proportion to the velocity. After the load is removed the coil spring pushes the piston rod outward. This unseats the check ring and permits the oil to flow from the accumulator and across the piston head, back into the shock tube. This allows quick repositioning for the next impact.

Low Pressure multiple orifice shock absorbers can provide progressive or self-compensating damping, depending on the impact conditions.

## Standard

ECO 8 → ECO 100 Series

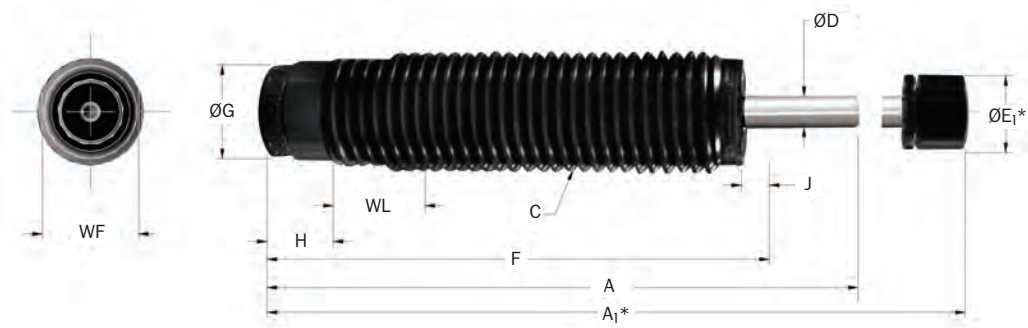

\*Note: A1 and E1 apply to button models and urethane striker cap accessory. One Hex Jam Nut included with every shock absorber.

Catalog No./ Model	(S) Stroke in. (mm)	(E <sub>T</sub> ) Max. in.-lbs./cycle (Nm/cycle)	(E <sub>T</sub> E) Emergency Max. in.-lbs./cycle (Nm/cycle)	(E <sub>T</sub> C) Max. in.-lbs./hour (Nm/h)	(F <sub>p</sub> ) Max. Reaction Force lbs. (N)	Nominal Coil Spring Force		(F <sub>D</sub> ) Max. Propelling Force lbs. (N)	Model Weight oz. (g)
						Extended lbs. (N)	Compressed lbs. (N)		
ECO 8 (B)	0.25 (6,4)	35 (4,0)	—	55,000 (6 215)	200 (890)	0.6 (2,7)	1.2 (5,6)	45 (200)	.5 (16)
ECO 10 (B)	0.28 (7,0)	62 (7,0)	—	120,700 (13 640)	360 (1 600)	0.5 (2,2)	1.0 (4,5)	80 (350)	1.0 (28)
ECO 15 (B)	0.41 (10,4)	106 (12,0)	220 (25)	275,000 (31 020)	450 (2 000)	0.7 (3,0)	1.6 (7,0)	50 (220)	2.0 (56)
ECO S 25 (B)	0.50 (12,7)	212 (24,0)	390 (44)	331,000 (37 400)	625 (2 800)	1.0 (4,5)	2.5 (11,0)	200 (890)	2.4 (68)
ECO 25 (B)	0.63 (16,0)	265 (30,0)	500 (56)	389,000 (44 000)	625 (2 800)	1.0 (4,5)	2.5 (11,0)	200 (890)	2.4 (68)
ECO S 50 (B)	0.50 (12,7)	285 (32,0)	560 (63)	440,000 (49 720)	850 (3 750)	1.5 (6,0)	3.5 (15,0)	360 (1 600)	3.0 (69)
ECO 50 (B)	0.88 (22,0)	550 (62,0)	975 (110)	523,000 (59 070)	850 (3 750)	2.0 (8,9)	6.8 (30,0)	360 (1 600)	4.8 (136)
ECO 100 (B)	1.00 (25,0)	930 (105,0)	2210 (250)	681,500 (77 000)	1,250 (5 500)	3.0 (13,0)	6.0 (27,0)	500 (2 200)	10.5 (297)

\*Notes: Maximum energy rating for emergency use only. Estimated cycle life of 1-5 cycles if used at maximum emergency rating.

Catalog No./ Model	Damping Constant	A in. (mm)	A <sub>1</sub> in. (mm)	C in. (mm)	D in. (mm)	E <sub>1</sub> in. (mm)	F in. (mm)	G in. (mm)	H in. (mm)	J in. (mm)	WF in. (mm)	WL in. (mm)
ECO 8 IF (B)	-1,-2,-3	1.86 (47,0)	2.25 (57,0)	3/8 - 32 UNEF	.10 (2,5)	0.27 (6,8)	1.61 (40,9)	.26 (6,6)	.18 (4,6)	.10 (2,5)	—	—
ECO 8 MF (B)	-1,-2,-3	—	—	M8 x 0,75	—	—	—	—	—	—	—	—
ECO 8 MC (B)	-1,-2,-3	—	—	M8 x 1,0	—	—	—	—	—	—	—	—
ECO 10 IF (B)	-1,-2,-3	2.12 (54,0)	2.51 (64,0)	7/16 - 28 UNEF	.12 (3,0)	0.34 (8,6)	1.83 (46,5)	.34 (8,6)	.18 (4,6)	.13 (3,3)	—	—
ECO 10 MF (B)	-1,-2,-3	—	—	M10 x 1,0	—	—	—	—	—	—	—	—
ECO 15 IF (B)	-1,-2,-3,-4	2.45 (62,2)	2.85 (72,4)	7/16 - 28 UNEF	.12 (3,0)	.40 (10,2)	2.10 (52,1)	.39 (9,9)	.27 (6,9)	.10 (2,5)	.39 (11,0)	.38 (9,5)
ECO 15 MF (B)	-1,-2,-3,-4	—	—	M12 x 1,0	—	—	—	—	—	—	—	—
ECO 15 IC (B)	-1,-2,-3,-4	—	—	1/2 - 20 UNEF	—	—	—	—	—	—	—	—
ECO S 25 MF (B)	-1,-2,-3	3.25 (82,7)	3.63 (92,2)	M14 x 1,0	.16 (4,0)	0.44 (11,2)	2.74 (69,5)	.43 (10,9)	.20 (5,1)	.04 (1,0)	.50 (12,7)	.50 (12,7)
ECO S 25 IC (B)	-1,-2,-3	—	—	1/16 - 18 UNF	—	—	—	—	—	—	—	—
ECO S 25 MC (B)	-1,-2,-3	—	—	M14 x 1,5	—	—	—	—	—	—	—	—
ECO 25 IF (B)	-1,-2,-3,-4	—	—	1/2 - 20 UNF	—	—	—	—	—	—	—	.44 (11,2)
ECO 25 MF (B)	-1,-2,-3,-4	3.84 (97,5)	4.22 (107,2)	M14 x 1,0	.16 (4,0)	.44 (11,2)	3.20 (81,3)	.43 (10,9)	.30 (7,6)	.04 (1,0)	.50 (12,7)	.50 (12,7)
ECO 25 IC (B)	-1,-2,-3,-4	—	—	1/16 - 18 UNF	—	—	—	—	—	—	—	—
ECO 25 MC (B)	-1,-2,-3,-4	—	—	M14 x 1,5	—	—	—	—	—	—	—	—
ECO S 50 IF (B)	-1,-2,-3	3.46 (87,9)	3.93 (99,9)	3/4 - 16 UNF	.19 (4,8)	0.50 (12,7)	2.93 (74,4)	.64 (16,3)	.30 (7,6)	.04 (1,0)	.68 (18,0)	.50 (12,7)
ECO S 50 MC (B)	-1,-2,-3	—	—	M20 x 1,5	—	—	—	—	—	—	—	—
ECO 50 IF (B)	-1,-2,-3,-4	4.66 (118,4)	5.13 (130,3)	3/4 - 16 UNF	.19 (4,8)	0.50 (12,7)	3.76 (95,5)	.64 (16,3)	.30 (7,6)	.04 (1,0)	.68 (18,0)	.50 (12,7)
ECO 50 MC (B)	-1,-2,-3,-4	—	—	M20 x 1,5	—	—	—	—	—	—	—	—
ECO 100 IF (B)	-1,-2,-3,-4	5.07 (128,8)	5.57 (141,5)	1-12 UNF	.25 (6,4)	0.62 (15,7)	4.04 (102,6)	.87 (22,0)	.50 (12,7)	.18 (4,6)	.88 (23,0)	.50 (12,7)
ECO 100 MF (B)	-1,-2,-3,-4	—	—	M25 x 1,5	—	—	—	—	—	—	—	—
ECO 100 MC (B)	-1,-2,-3,-4	—	—	M27 x 3,0	—	—	—	—	—	—	—	—

Notes: 1. See page 54 for constant damping curves.

# Non-Adjustable Series Hydraulic Shock Absorbers

## ECO Series

### Accessories

ECO 8 → ECO 100 Series

### Jam Nut (JN)

\*Note: One Hex Jam Nut included with every shock absorber.

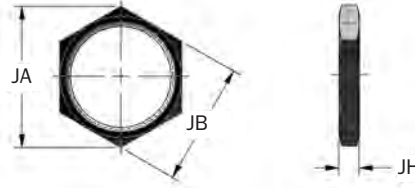

Catalog No./ Model	ECO Series Part Number	Model (Ref)	JA in. (mm)	JB in. (mm)	JH in. (mm)	Weight (mass) oz. (g)
JN 3/8 - 32	J123839034	ECO 8 (B)	0.58	0.50	.09	0.1
JN M8 x 0,75	J223839185	ECO 8 MF (B)	(14,0)	(12,0)	(4,0)	(2)
JN M8 x 1	J223839035	ECO 8 MC (B)	(14,0)	(12,0)	(4,0)	(2)
JN 7/16 - 28	J123840034	ECO 10 IF (B)/ECO 15 (B)	0.65	0.56	.16	0.1
JN M10 x 1	J223840167	ECO 10 MF (B)	(17,3)	(15,0)	(4,0)	(2)
JN M12 x 1	J223841035	ECO 15 M (B)	(15,0)	(13,0)	(3,2)	(2)
JN 1/2 - 20	J123842166	ECO 25 IF (B)	0.72	0.63	.12	0.1
JN M14 x 1	J223842035	ECO S/ECO 25 MF (B)	(19,7)	(17,0)	(4,0)	(3)
JN 9/16 - 18	J123842034	ECO S/ECO 25 IC (B)	1.01	0.88	.31	0.6
JN M14 x 1,5	J223842165	ECO S/ECO 25 MC (B)	(19,7)	(17,0)	(4,0)	(3)
JN 3/4 - 16	J123844034	ECO S/ECO 50 IC (B)	1.08	0.94	.18	0.3
JN M20 x 1,5	J223844035	ECO S/ECO 50 MC (B)	(27,7)	(24,0)	(4,6)	(7)
JN 1-12	J123846034	ECO 100 (B)	1.30	1.13	.18	0.5
JN M25 x 1,5	J223846035	ECO 100 MF (B)	(37,0)	(32,0)	(4,6)	(15)

### Stop Collar (SC)

ECO8 → ECO100

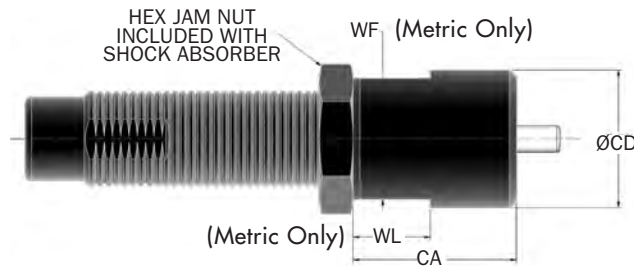

Catalog No./ Model	ECO Series Part Number	Model (Ref)	CA in. (mm)	CB in. (mm)	CD in. (mm)	WF in. (mm)	WL in. (mm)	Weight (mass) oz. (g)
SC 3/8 - 32	M923839057	ECO 8 (B)	0.75	.50	0.58	-	-	.5
SC M8 x 0,75	M923839175	ECO 8 MF (B)	(19,0)	(12,0)	(14,0)	-	-	(23)
SC M8 x 1	M923839058	ECO 8 MC (B)	(19,0)	(12,0)	(14,0)	-	-	(23)
SC 7/16 - 28	M923841057	ECO 10 IF (B)	0.75	-	0.63	-	-	.5
SC M10 x 1	M923840171	ECO 10 MF (B)	(19,0)	-	(14,0)	-	-	(11)
SC 7/16 - 28	M923841057	ECO 15 (B)	0.75	-	0.63	-	-	.5
SC M12 x 1	M923841058	ECO 15 M (B)	(19,0)	-	(16,0)	(14,0)	(9,0)	(14)
SC 1/2 - 20	M923842057	ECO 25 IF (B)	1.00	-	0.75	-	-	1.0
SC M14 x 1,5	M923842171	ECO S/ECO 25 MF (B)	(25,4)	-	(21,0)	(19,0)	(12,0)	(38)
SC 9/16 - 18	M923842199	ECO S/ECO 25 IC (B)	1.00	-	0.69	-	-	1.0
SC M14 x 1	M923842058	ECO S/ECO 25 MF (B)	(25,4)	-	(19,0)	(17,0)	(12,0)	(20)
SC 3/4 - 16	M923844057	ECO S/ECO 50 (B)	1.50	-	1.00	-	-	2.0
SC M20 x 1,5	M924057058	ECO S/ECO 50 M (B)	(38,0)	-	(25,0)	(22,0)	(12,0)	(63)
SC 1-12 x 1	M923846057	ECO 100 (B)	1.75	-	1.50	-	-	8.0
SC M25 x 1,5	M923846171	ECO 100 MF (B)	(44,5)	-	(38,0)	(32,0)	(15,0)	(215)

ECO 8 → ECO 100 Series

Side Load Adaptor (SLA)

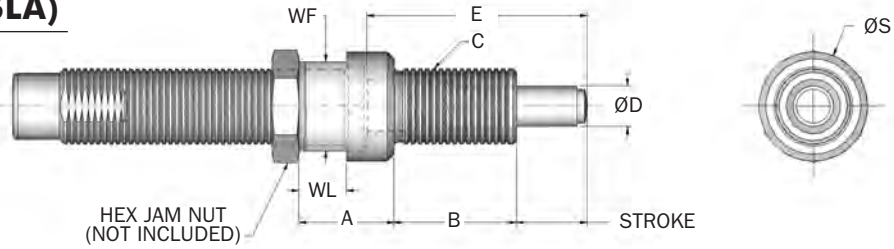

Catalog No./ Model	ECO Series Part Number	Model (Ref)	Stroke in. (mm)	A in. (mm)	B in. (mm)	C in. (mm)	D in. (mm)	E in. (mm)	S in. (mm)	WF in. (mm)	WL in. (mm)
SLA 7/16 - 28 x .28	SLA 33974	ECO 10	.28 (6,4)	.43 (11)	.47 (12)	7/16-28 UNEF	.20 (5,0)	.87 (21,9)	.63 (13,0)	.56 (11,0)	.16 (4,0)
SLA 10 MF	SLA 33457	ECO 10 MF				M10 x 1					
SLA 7/16 - 28 x .41	SLA 33844	ECO 15 IF	.41 (10,0)	.55 (14)	.71 (18)	7/16-28 UNEF	.24 (6,0)	1.28 (32,4)	.63 (14,0)	.56 (13,0)	.28 (7,0)
SLA 12 MF	SLA 33299	ECO 15 MF				M12 x 1					
SLA 1/2 - 20 x .41	SLA 71146	ECO 15 IC	.41 (10,0)	.55 (14)	.71 (18)	1/2-20 UNF	.24 (6,0)	1.28 (32,4)	.63 (14,0)	.56 (13,0)	.28 (7,0)
SLA 1/2 - 20 x .63	SLA 33849	ECO 25 IF	.63 (16,0)	.51 (13)	1.02 (26)	1/2-20 UNF	.31 (8,0)	1.62 (41,5)	.71 (18,0)	.63 (15,0)	.28 (7,0)
SLA 14 MF	SLA 33297	ECO 25 MF				M14 x 1					
SLA 7/16 - 18 x .63	SLA 33850	ECO 25 IC	.63 (16,0)	.51 (13)	1.02 (26)	7/16-18 UNF	.31 (8,0)	1.62 (41,5)	.71 (18,0)	.63 (15,0)	.28 (7,0)
SLA 14 MC	SLA 33298	ECO 25 MC				M14 x 1,5					
SLA 14 MFS	SLA 33306	ECO S 25 MF				M14 x 1					
SLA 7/16 - 18 x .50	SLA 33846	ECO S 25 IC	.5 (12,7)	.63 (16)	.79 (20)	7/16-18 UNF	.31 (8,0)	1.55 (39,2)	.71 (18,0)	.63 (15,0)	.28 (7,0)
SLA 14 MCS	SLA 33301	ECO S 25 MC				M14 x 1,5					
SLA 3/4 - 16 x .88	SLA 33851	ECO 50	.88 (22,0)	.67 (17)	1.26 (32)	3/4-16 UNF	.43 (11,0)	2.44 (62,0)	.98 (25,0)	.88 (22,0)	.28 (7,0)
SLA 20 MC	SLA 33302	ECO 50 M				M20 x 1,5					
SLA 3/4 - 16 x .50	SLA 33847	ECO S 50	.5 (12,7)	.55 (14)	.94 (24)	3/4-16 UNF	.43 (11,0)	1.64 (41,5)	.98 (25,0)	.88 (22,0)	.28 (7,0)
SLA 20 MCS	SLA 33262	ECO S 50 M				M20 x 1,5					
SLA 1-12 x 1	SLA 33848	ECO 100	1.00 (25,4)	1.18 (30)	1.50 (38)	1-12 UNF	.59 (15,0)	2.88 (73,2)	1.42 (36,0)	1.25 (32,0)	.39 (10,0)
SLA 25 MF	SLA 33263	ECO 100 MF				M25 x 1,5					
SLA 25 MC	SLA 33296	ECO 100 MC				M27 x 3					

Notes: 1. Maximum sideload angle is 30°. 2. Part numbers in page color are non-standard lead time items, contact Enidine.

Universal Retaining Flange (UF)

UF 7/8 - 32 → UF 1/2 - 20  
UF M10 x 1 → UF M14 x 1,5

UF 7/16 - 18 → UF 3/4 - 16  
UF M20 x 1,5 → UF M27 x 3

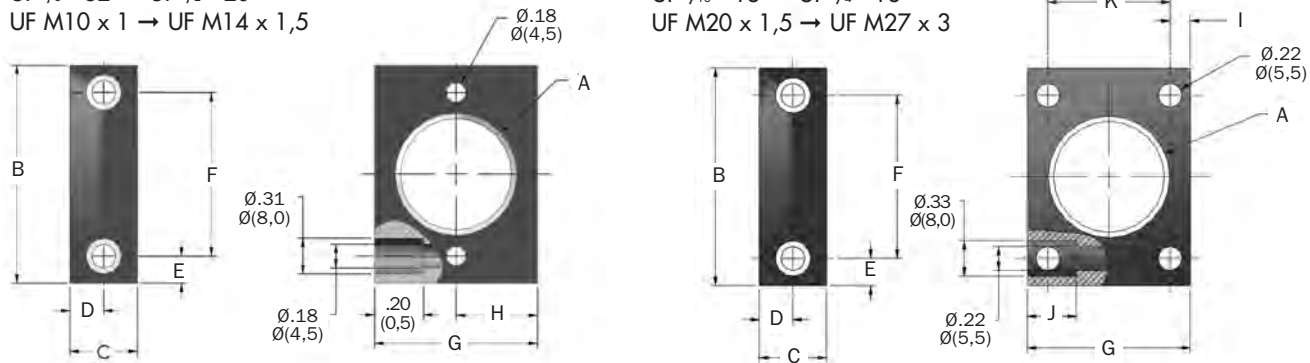

Catalog No./ Model	ECO Series Part Number	Model (Ref)	A in. (mm)	B in. (mm)	C in. (mm)	D in. (mm)	E in. (mm)	F in. (mm)	G in. (mm)	H in. (mm)	I in. (mm)	J in. (mm)	K in. (mm)
UF M10 x 1	U16363189	ECO 10M	M10 x 1 (38,0)	(12,0)	(6,0)	(6,25)	(25,5)	(25,0)	(12,5)	—	(5,0)	—	—
UF 7/16 - 28	U15588095	ECO 15 (B)/ECO 10 (B)	7/16 - 28 UNF	1.50	.56	.28	.25	1.00	1.00	0.50	—	.20	—
UF M12 x 1	U15588189	ECO 15 M (B)	M12 x 1 (38,0)	(12,0)	(6,0)	(6,25)	(25,5)	(25,0)	(12,5)	—	(5,0)	—	—
UF 1/2 - 20	U13935095	ECO 25 IF (B)	1/2 - 20 UNF	1.50	.56	.28	.25	1.00	1.00	0.50	—	.20	—
UF M14 x 1	U14950189	ECO/ECO S 25 MF (B)	M14 x 1,5 (45,0)	(16,0)	(8,0)	(5,0)	(35,0)	(30,0)	(15,0)	—	(5,0)	—	—
UF 7/16 - 18	U19018095	ECO/ECO S 25 IC (B)	7/16 - 18 UNF	1.81	.62	.31	.22	1.38	1.38	—	.19	.32	1.00
UF M14 x 1,5	U13935143	ECO/ECO S 25 MC (B)	M14 x 1,5 (45,0)	(16,0)	(8,0)	(5,0)	(35,0)	(30,0)	(15,0)	—	(5,0)	—	—
UF 3/4 - 16	U120275095	ECO/ECO S 50 (B)	3/4 - 16 UNF	2.00	.62	.31	.25	1.50	1.50	—	.19	.45	1.12
UF M20x 1,5	U12646143	ECO/ECO S 50 MC (B)	M20 x 1,5 (48,0)	(16,0)	(8,0)	(6,5)	(35,0)	(35,0)	(15,0)	—	(4,75)	(10,0)	(25,5)
UF 1-12	U19599095	ECO 100	1-12 UNF	2.00	.62	.31	.25	1.50	1.50	—	.19	.39	(25,5)
UF M25 x 1,5	U13004143	ECO 100/110M	M25 x 1,5 (48,0)	(16,0)	(8,0)	(6,5)	(35,0)	(35,0)	(15,0)	—	(4,75)	(10,0)	(25,5)
UF M27 x 3	U12587143	ECO 100 MC	M27 x 3 (48,0)	(16,0)	(8,0)	(6,5)	(35,0)	(35,0)	(15,0)	—	(4,75)	(10,0)	(25,5)

Notes: 1. Part numbers in page color are non-standard lead time items, contact ITT Enidine.

Non-Adjustable Series

# Non-Adjustable Series Hydraulic Shock Absorbers

## ECO Series

PRO 110 → ECO 225 Series

### Technical Data

### Standard



\*Note: A<sub>1</sub> and E<sub>1</sub> apply to button models and urethane striker cap accessory.

Catalog No./ Model	(S) Stroke in. (mm)	(E <sub>T</sub> ) Max. in.-lbs./cycle (Nm/cycle)	(E <sub>T</sub> E) Emergency Max. in.-lbs./cycle (Nm/cycle)	(F <sub>P</sub> ) (E <sub>T</sub> C) Max. in.-lbs./hour (Nm/h)	(F <sub>D</sub> ) Max. Reaction Force lbs. (N)	Nominal Coil Spring Force		Max. Propelling Force lbs. (N)	Weight (mass) oz. (g)
						Extended lbs. (N)	Compressed lbs. (N)		
PRO 110 IF (B)	1.56 (40,0)	1,700 (190,0)	—	670,000 (75 700)	1,700 (7 500)	4.0 (18,0)	11.0 (49,0)	500 (2 220)	16.0 (454)
PRO 110 MF (B)	(40,0)	(190,0)	—	(75 700)	(7 500)	(18,0)	(49,0)	(2 220)	(454)
PRO 110 MC (B)	(40,0)	(190,0)	—	(75 700)	(7 500)	(18,0)	(49,0)	(2 220)	(454)
ECO 120 IF (B)	1.00 (25,0)	1,640 (185,0)	4,425 (500)	743,500 (84 000)	2,500 (11 120)	12.5 (56,0)	20.0 (89,0)	700 (3 100)	17.0 (482)
ECO 120 MF (B)	(25,0)	(185,0)	(500)	(84 000)	(11 120)	(56,0)	(89,0)	(3 100)	(482)
ECO 125 IF (B)	1.00 (25,0)	1,640 (185,0)	4,425 (500)	920,500 (104 000)	2,500 (11 120)	12.5 (56,0)	20.0 (89,0)	700 (3 100)	21.0 (595)
ECO 125 MF (B)	(25,0)	(185,0)	(500)	(104 000)	(11 120)	(56,0)	(89,0)	(3 100)	(595)
ECO 220 IF (B)	2.00 (50,0)	3,100 (350,0)	8,850 (1 000)	911,600 (103 000)	2,500 (11 120)	7.0 (31,0)	20.0 (89,0)	700 (3 100)	23.0 (652)
ECO 220 MF (B)	(50,0)	(350,0)	(1 000)	(103 000)	(11 120)	(31,0)	(89,0)	(3 100)	(652)
ECO 225 IF (B)	2.00 (50,0)	3,100 (350,0)	8,850 (1 000)	1,124,000 (127 000)	2,500 (11 120)	7.0 (31,0)	20.0 (89,0)	700 (3 100)	27.0 (765)
ECO 225 MF (B)	(50,0)	(350,0)	(1 000)	(127 000)	(11 120)	(31,0)	(89,0)	(3 100)	(765)

Notes: \*Maximum energy rating for emergency use only. Estimated cycle life of 1-5 cycles if used at maximum emergency rating.

Catalog No./ Model	Damping Constant	A in. (mm)	A <sub>1</sub> in. (mm)	C in. (mm)	D in. (mm)	E in. (mm)	E <sub>1</sub> in. (mm)	F in. (mm)	J in. (mm)	WF in. (mm)	WL in. (mm)
PRO 110 IF (B)**	-1,-2,-3	7.93	8.06	1-12 UNF	.31	0.88	0.88	5.00	.06	—	—
PRO 110 MF (B)**	-1,-2,-3	(201,4)	(204,7)	(M25 x 1,5)	(8,0)	(22,2)	(22,2)	(127,0)	(1,5)	—	—
PRO 110 MC (B)**	-1,-2,-3	(201,4)	(204,7)	(M25 x 2,0)	(8,0)	(22,2)	(22,2)	(127,0)	(1,5)	—	—
ECO 120 IF (B)	-1,-2,-3	5.52	5.72	1 1/4-12 UNF	.38	1.13	1.20	3.41	.21	1.12	.63
ECO 120MF (B)	-1,-2,-3	(140,2)	(145,3)	M33 x 1,5	(9,5)	(29,0)	(30,5)	(87,0)	(5,3)	(30,0)	(16,0)
ECO 125 IF (B)	-1,-2,-3	5.52	5.72	1 3/8-12 UNF	.38	1.13	1.20	3.41	.21	1.12	.63
ECO 125 MF (B)	-1,-2,-3	(140,2)	(145,3)	M36 x 1,5	(9,5)	(29,0)	(30,5)	(87,0)	(5,3)	(33,0)	(16,0)
ECO 220 IF (B)	-1,-2,-3	8.14	8.34	1 1/4-12 UNF	.38	1.13	1.20	5.03	.21	1.12	.63
ECO 220 MF (B)	-1,-2,-3	(207,0)	(212,0)	M33 x 1,5	(9,5)	(29,0)	(30,5)	(128,0)	(5,3)	(30,0)	(16,0)
ECO 225 IF (B)	-1,-2,-3	8.14	8.34	1 3/8-12 UNF	.38	1.13	1.20	5.03	.21	1.25	.63
ECO 225 MF (B)	-1,-2,-3	(207,0)	(212,0)	M36 x 1,5	(9,5)	(29,0)	(30,5)	(128,0)	(5,3)	(33,0)	(16,0)

Notes: 1. See page 55 for constant damping curves.

\*\*The PRO 110 Model is a Nickel Plated Shock Absorber.

ECO 120 → ECO 225 Series

**Clevis Mount**

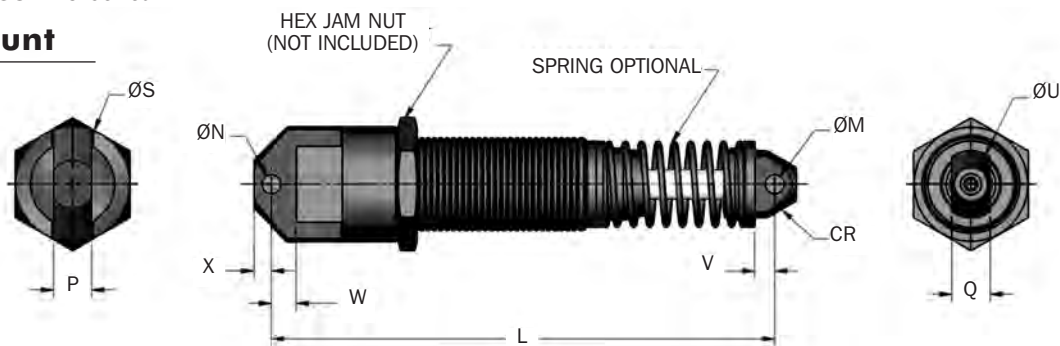

Catalog No./ Model	L in. (mm)	M +.005/- .000 in. (mm)	N +.005/- .000 in. (mm)	P +.000/- .010 in. (mm)	Q +.000/- .010 in. (mm)	S in. (mm)	U in. (mm)	V in. (mm)	W in. (mm)	X in. (mm)	CR in. (mm)	Weight (mass) lbs. (Kg)
ECO 120 CM (S)	6.59 (167)	.251 (6,38)	.251 (6,38)	.500 (12,70)	.500 (12,70)	1.50 (38)	.88 (23)	.23 (6)	.48 (12)	.31 (6,1)	.44 (11,2)	1.3 (0,59)
ECO 220 CM (S)	9.22 (234)	.251 (6,38)	.251 (6,38)	.500 (12,70)	.500 (12,70)	1.50 (38)	.88 (23)	.23 (6)	.48 (12)	.31 (6,1)	.44 (11,2)	1.7 (0,77)
ECO 125 CM (S)	6.59 (180)	.251 (6,38)	.251 (6,38)	.500 (12,70)	.500 (12,70)	1.50 (38)	.88 (22)	.23 (6)	.93 (24)	.23 (6,0)	.44 (11,2)	1.6 (0,73)
ECO 225 CM (S)	9.22 (230)	.251 (6,38)	.251 (6,38)	.500 (12,70)	.500 (12,70)	1.50 (38)	.88 (22)	.23 (6)	.93 (24)	.23 (6,0)	.44 (11,2)	1.9 (0,86)

Notes: 1. (S) indicates model comes with spring.

**Flange Foot Mount**

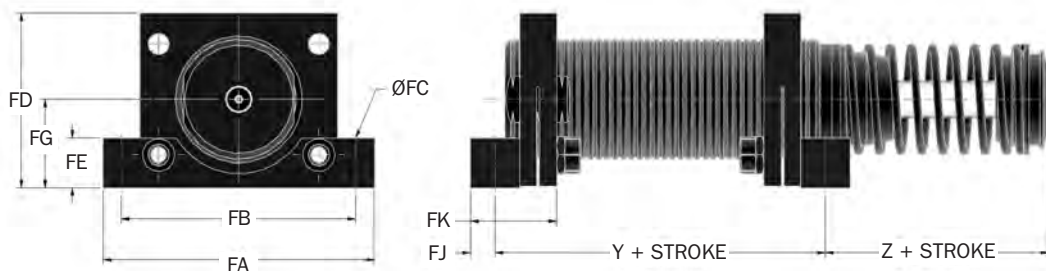

Catalog No./ Model	Part Number	Model (Ref)	Y in. (mm)	Z in. (mm)	FA in. (mm)	FB in. (mm)	FC in. (mm)	FD in. (mm)	FE in. (mm)	FG in. (mm)	FJ in. (mm)	FK in. (mm)	Bolt Size in. (mm)	Kit Weight oz. (g)
FM 1 1/4 - 12	2F21049305	ECO 120/220	2.25	1.25	2.75	2.38	.23	1.77	.50	.90	.25	.88	#10	4.0
FM M33 x 1,5	2F21049306	ECO 120/220M	(57,2)	(31,8)	(70,0)	(60,3)	(5,90)	(45,0)	(12,7)	(22,7)	(6,4)	(22,2)	(M5)	(100)
FM 1 3/8 - 12	2F21293305	ECO 125/225	2.25	1.25	2.75	2.38	.23	1.77	.50	.90	.25	.88	#10	4.0
FM M36 x 1,5	2F21293306	ECO 125/225M	(57,2)	(31,8)	(70,0)	(60,3)	(5,90)	(45,0)	(12,7)	(22,7)	(6,4)	(22,2)	(M5)	(100)

Notes: 1. Shock absorber must be ordered separately from foot mount kit.  
2. All foot mount kits include two foot mounts.

# Non-Adjustable Series Hydraulic Shock Absorbers

## ECO Series

ECO 120 → ECO 225 Series

Accessories

### Stop Collar (SC)

Non-Adjustable Series

#### Imperial

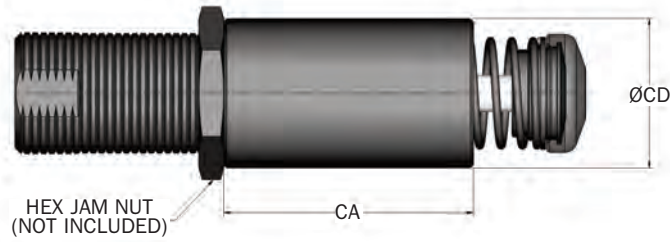

#### Metric



Catalog No./ Model	Part Number	Model (Ref)	CA in. (mm)	CD in. (mm)	WF in. (mm)	WL in. (mm)	Weight (mass) oz. (g)
SC 1 1/4-12	M921049057	ECO 120/220	2.50	1.50	–	–	7.0
SC M33 x 1,5	M930290171	ECO 120/220 M	(41,0)	(38,0)	(36,0)	(17,0)	(210)
SC 1 3/8-12	M921293057	ECO 120/220	2.50	1.69	–	–	7.0
SC M36 x 1,5	M930285058	ECO 120/220 M	(63,5)	(43,0)	(41,0)	(18,0)	(210)

### Jam Nut (JN)

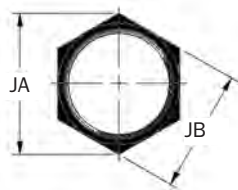

Catalog No./ Model	Part Number	Model (Ref)	JA in. (mm)	JB in. (mm)	JH in. (mm)	Weight (mass) oz. (g)
JN 1 1/4-12	J18609034	ECO 120/220	1.73	1.50	.25	0.9
JN M33 x 1,5	J28609035	ECO 120/220 M	(47,3)	(41,0)	(6,4)	(27)
JN 1 3/8-12	J13164034	ECO 125/225	1.73	1.50	.25	0.9
JN M36 x 1,5	J23164034	ECO 125/225 M	(47,3)	(41,0)	(6,4)	(27)

ECO 120 → ECO 225 Series

**Urethane Striker Cap (USC)**

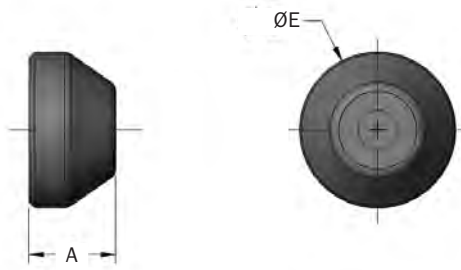

Catalog No./ Model	Part Number	Model (Ref)	A in. (mm)	E1 in. (mm)	Weight (mass) oz. (g)
UC 8609	C98609079	ECO 120, 125, 220 & 225	.39 (10,0)	1.20 (30,5)	0.1 (3)

**Rectangular Flange (RF)**

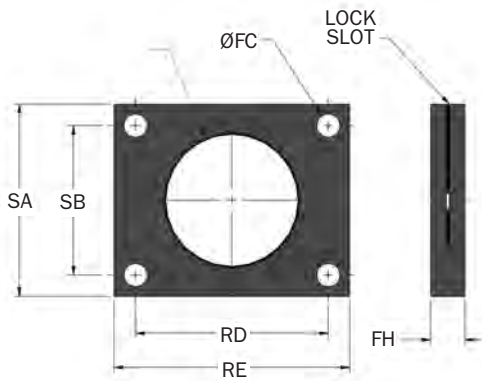

Catalog No./ Model	Part Number	Model (Ref)	FC in. (mm)	FH in. (mm)	RD in. (mm)	RE in. (mm)	SA in. (mm)	SB in. (mm)	Bolt Size in. (mm)	Wt. (mass) oz. (g)
RF 1 1/4 - 12	N121049129	ECO 120/220	.22	.38	1.63	2.00	1.75	1.13	#10	1.0
RF M33 x 1,5	N121049141	ECO 120/ 220M	(5,5)	(9,5)	(41,3)	(50,8)	(44,5)	(28,6)	(M5)	(30)
RF 1 3/4 - 12	N121293129	ECO 125/225	.22	.38	1.63	2.00	1.75	1.13	#10	1.0
RF M36 x 1,5	N121293129	ECO 125/225M	(5,5)	(9,5)	(41,3)	(58,8)	(44,5)	(28,6)	(M5)	(30)



# Non-Adjustable Series Hydraulic Shock Absorbers

ECO 8 → ECO S50 Series

## Sizing Curves

Non-Adjustable Series

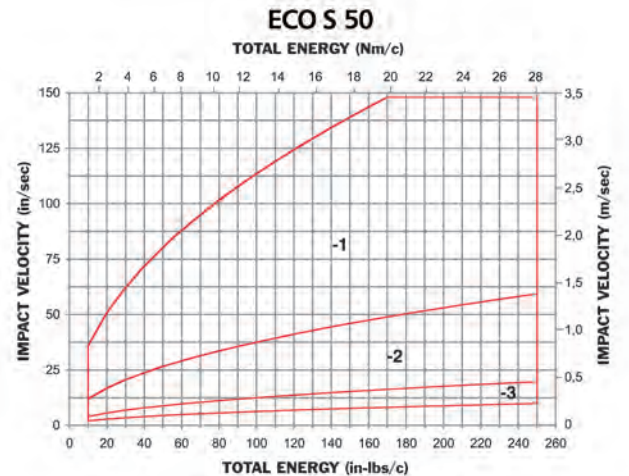
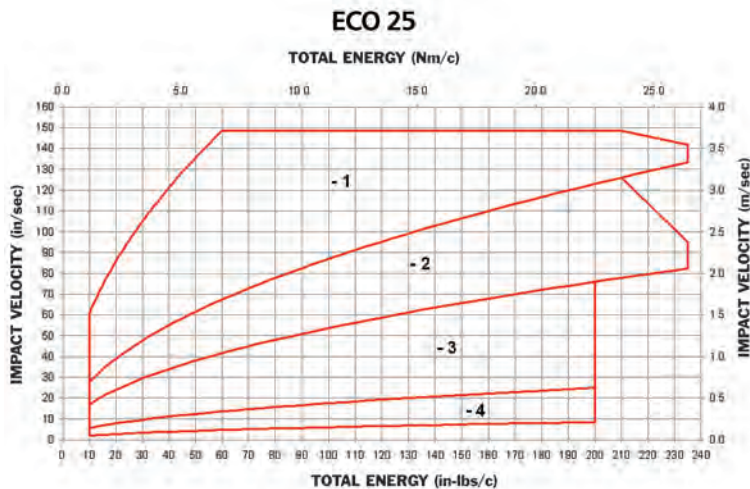
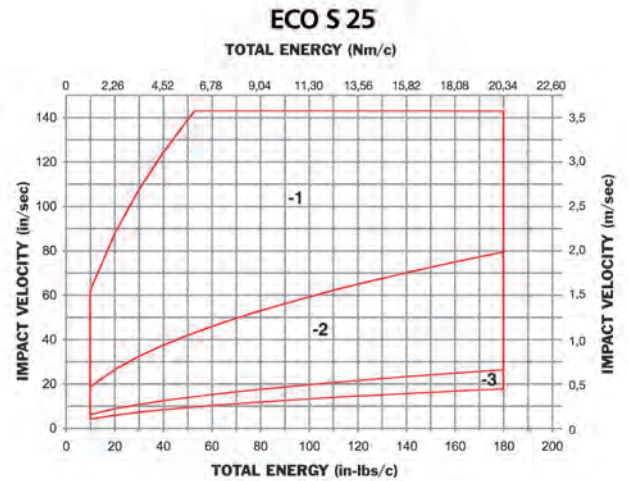
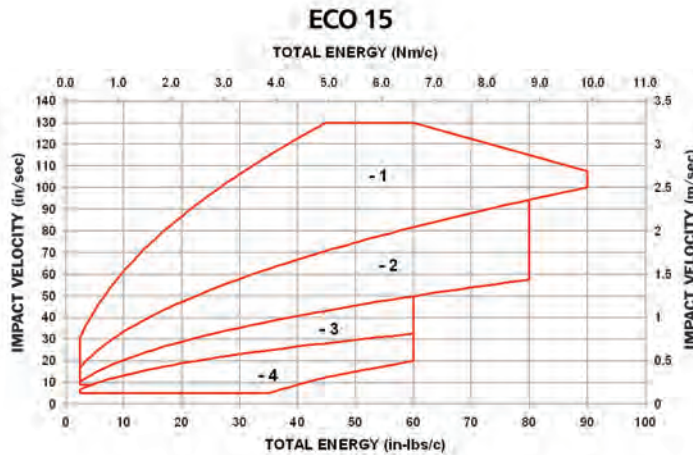
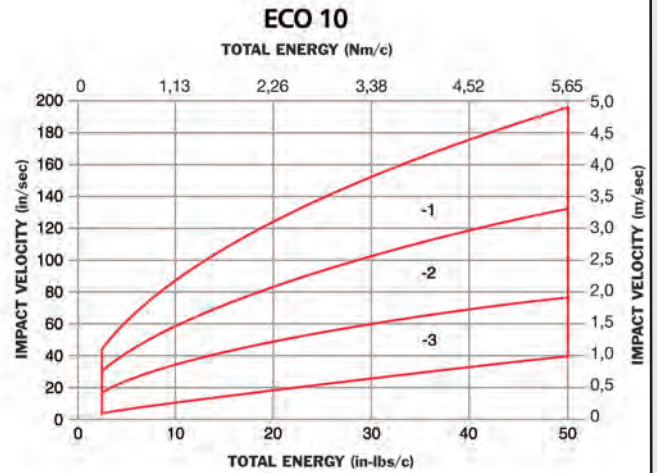
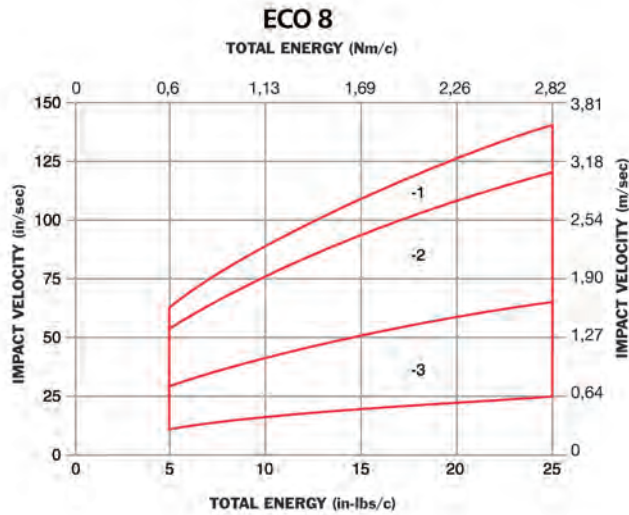

Note: Minimum impact velocity for ECO models is 4 in./sec. (0,1 m/sec).

ECO 50 → ECO 225 Series

Non-Adjustable Series

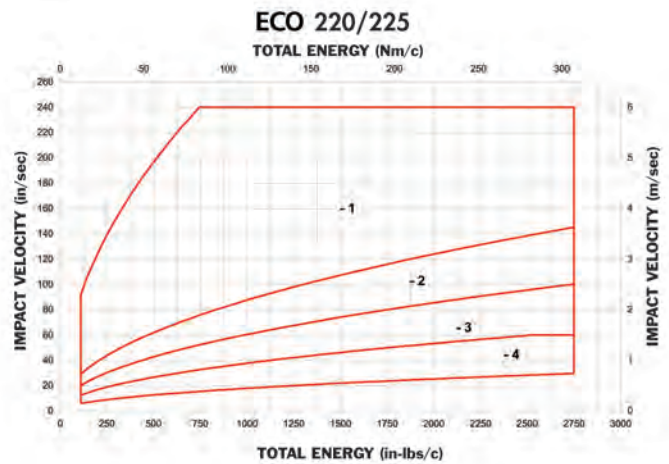
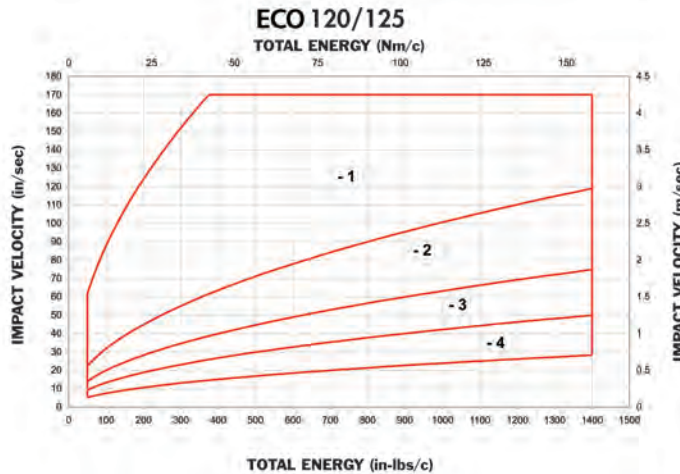
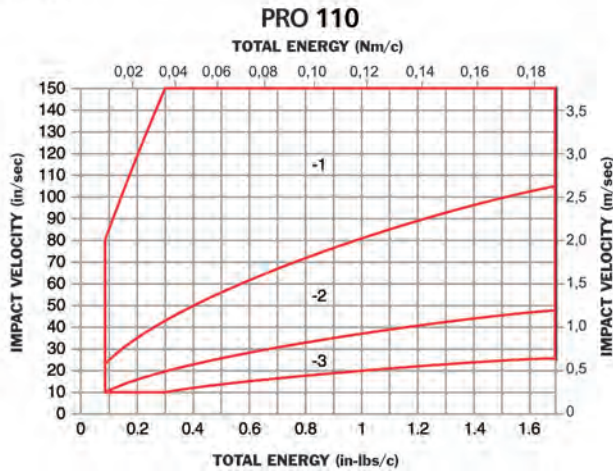
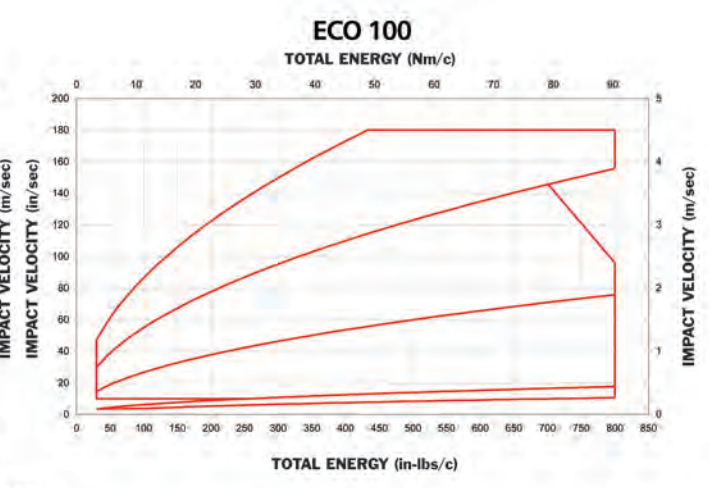
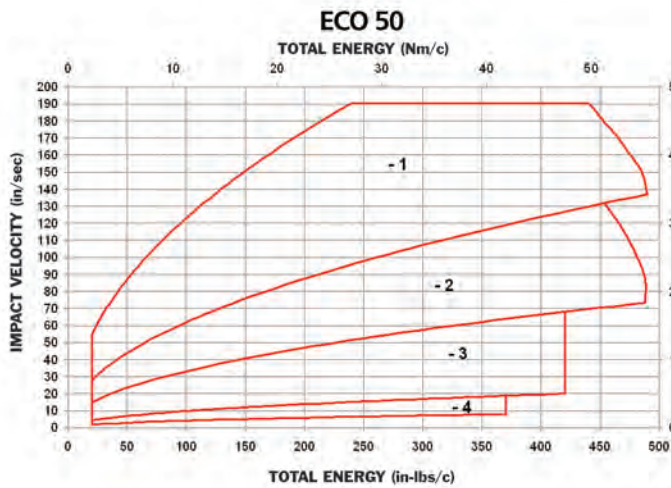

Note: Minimum impact velocity for PRO and ECO models is 4 in./sec. (0,1 m/sec).

### Typical Applications

Non-Adjustable Series



Factory Automation

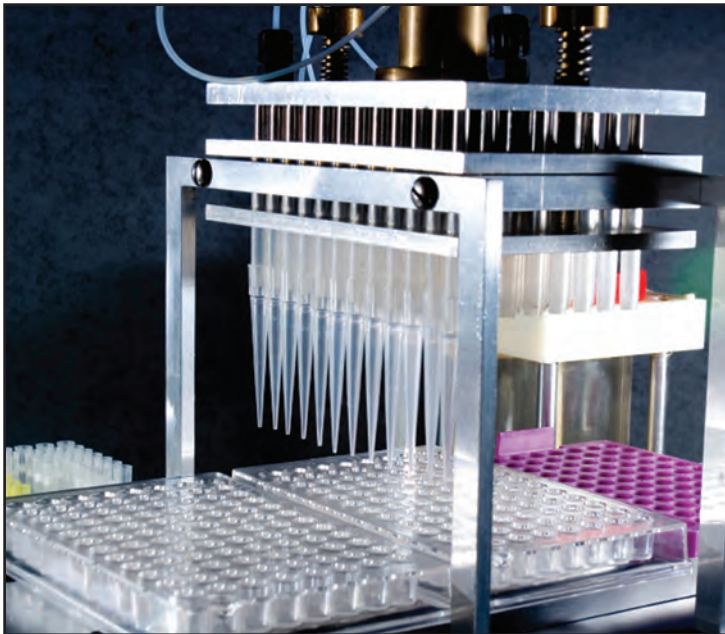

Medical Laboratory Equipment



Food Processing



ITT Enidine's **New PXR Series** non-adjustable hydraulic shock absorbers can accommodate varying energy conditions. This family of tamperproof shock absorbers provides consistent performance, cycle after cycle. Non-adjustable models are designed to absorb maximum energy within a compact envelope size.

The **PXR Series** was designed using materials that are safe for our environment. Models can accommodate a wide range of operating conditions with varying masses or propelling forces. The **PXR Series** offers a flexible design to accommodate a wide variety of application parameters. Whether your application has a low velocity/high drive force or high velocity/low drive force condition, the **New PXR Series** will deliver the performance that you have come to expect.

## Features and Benefits

- **Extensive non-adjustable product line** offers flexibility in both size and energy absorption capacity to fulfill a wide range of application requirements.
- **RoHS compliant nickel plated steel body.**
- **Jam Nut included** with every shock absorber.
- **ISO quality standards** result in reliable, long-life operation.
- **Button model supplied** with a larger diameter, more durable button than standard.
- **Tamperproof design** ensures repeatable performance.
- **Threaded cylinders provide mounting flexibility** and increase surface area for improved heat dissipation.
- **Wrench flats** promote ease of mounting
- **Capability to mount into pressure chambers** up to 100 psi (7 bar).
- **Integrated positive stopping capabilities**
- **Special materials and finishes** can be designed to meet specific customer requirements
  - Optional fluids and seal packages can expand the standard operating temperature range from (15°F to 180°F) to (-30°F to 210°F)
  - Food grade options available

# Non-Adjustable Series Hydraulic Shock Absorbers

PXR Series

Overview

## ITT Enidine Non-Adjustable Multiple Orifice Shock Absorbers

Non-Adjustable Series

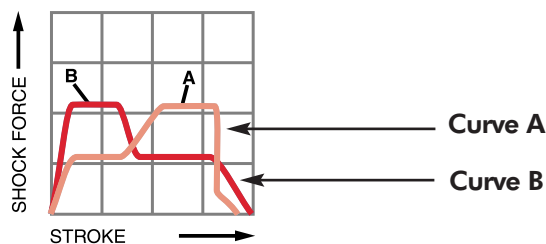
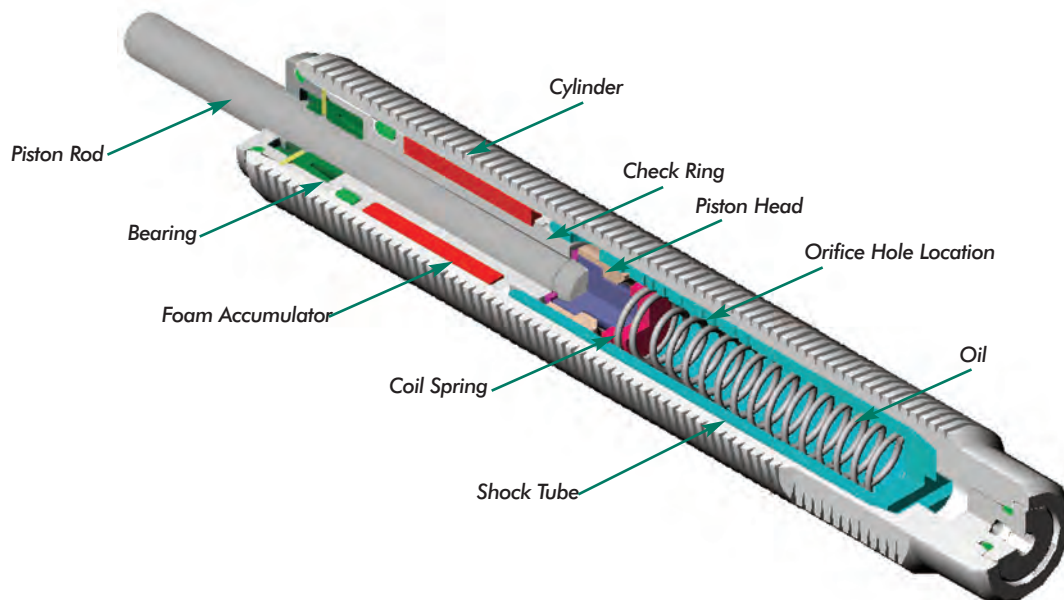

**Self-compensating damping** maintains acceptable deceleration with conventional type damping characteristics. Self-compensating shock absorbers operate over a wide range of weights and velocities. These shock absorbers are well suited for high drive force, low velocity applications, and where energy conditions may change. **Curve A** shows the *shock force vs. stroke* curve of a self-compensating shock absorber impacted with a low velocity and high drive force. **Curve B** shows the *shock force vs. stroke* curve of a self-compensating shock absorber impacted with a high velocity and low drive force.

The design of a multi-orifice shock absorber features a double cylinder arrangement with space between the concentric shock tube and cylinder, and a series of orifice holes drilled down the length of the shock tube wall.

During piston movement, the check ring is seated and oil is forced through the orifices in the shock tube wall, into the closed cellular foam accumulator and behind the piston head.

As the piston head moves it closes off orifice holes, thus reducing the available orifice area in proportion to the velocity. After the load is removed the coil spring pushes the piston rod outward. This unseats the check ring and permits the oil to flow from the accumulator and across the piston head, back into the shock tube. This allows quick repositioning for the next impact.

Multiple orifice shock absorbers can provide progressive or self-compensating damping, depending on the impact conditions.

## Standard

PXR 25 → PXR 100 Series

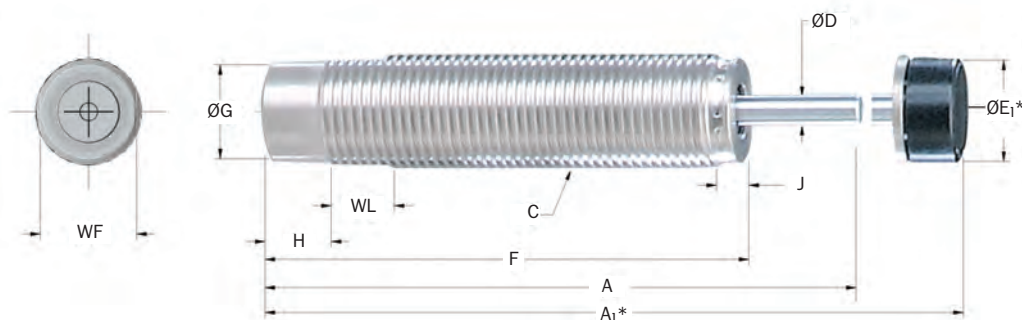

\*Note: A<sub>1</sub> and E<sub>1</sub> apply to button models and urethane striker cap accessory. One Hex Jam Nut included with every shock absorber.

Catalog No./ Model	(S) Stroke in. (mm)	(E <sub>T</sub> ) Max. in.-lbs./cycle (Nm/cycle)	(E <sub>T</sub> E) Emergency Max. in.-lbs./cycle (Nm/cycle)	(E <sub>T</sub> C) Max. in.-lbs./hour (Nm/h)	(F <sub>P</sub> ) Max. Reaction Force lbs. (N)	Nominal Coil Spring Force		(F <sub>D</sub> ) Max. Propelling Force lbs. (N)	Model Weight oz. (g)
						Extended lbs. (N)	Compressed lbs. (N)		
PXR 25 (B)	0.63 (16,0)	265 (30,0)	500 (56)	389,000 (44 000)	625 (2 800)	1.0 (4,5)	2.5 (11,0)	200 (890)	2.4 (68)
PXR S 50 (B)	0.50 (12,7)	285 (32,0)	560 (63)	440,000 (49 720)	850 (3 750)	1.5 (6,0)	3.5 (15,0)	360 (1 600)	3.0 (69)
PXR 100 (B)	1.00 (25,0)	930 (105,0)	2210 (250)	681,500 (77 000)	1,250 (5 500)	3.0 (13,0)	6.0 (27,0)	500 (2 200)	10.5 (297)

\*Notes: Maximum energy rating for emergency use only. Estimated cycle life of 1-5 cycles if used at maximum emergency rating.

Catalog No./ Model	Damping Constant	A in. (mm)	A <sub>1</sub> in. (mm)	C in. (mm)	D in. (mm)	E <sub>1</sub> in. (mm)	F in. (mm)	G in. (mm)	H in. (mm)	J in. (mm)	WF in. (mm)	WL in. (mm)
PXR 25 IF (B)	-5,-6,-7			½ - 20 UNF							.44	
PXR 25 MF (B)	-5,-6,-7	3.84	4.22	M14 x 1,0	.16	.44	3.20	.43	.30	.04	(12,0)	.50
PXR 25 IC (B)	-5,-6,-7			¾ - 18 UNF	(4,0)	(11,2)	(81,3)	(10,9)	(7,6)	(1,0)	.50	(12,7)
PXR 25 MC (B)	-5,-6,-7			M14 x 1,5							(12,0)	
PXR S 50 IF (B)	-5,-6,-7,-8,-9	3.46	3.93	¾ - 16 UNF	.19	.66	2.93	.64	.30	.04	.69	.50
PXR S 50 MC (B)	-5,-6,-7,-8,-9	(87,9)	(99,9)	M20 x 1,5	(4,8)	(16,8)	(74,4)	(16,3)	(7,6)	(1,0)	(18,0)	(12,7)
PXR 100 IF (B)	-5,-6,-7,-8,-9			1-12 UNF								
PXR 100 MF (B)	-5,-6,-7,-8,-9	5.07	5.57	M25 x 1,5	.25	.88	4.04	.87	.50	.18	.88	.50
PXR 100 MC (B)	-5,-6,-7,-8,-9	(128,8)	(141,5)	M27 x 3,0	(6,4)	(22,2)	(102,6)	(22,0)	(12,7)	(4,4)	(22,8)	(12,7)

Notes: 1. See page 60 for damping constant curves.

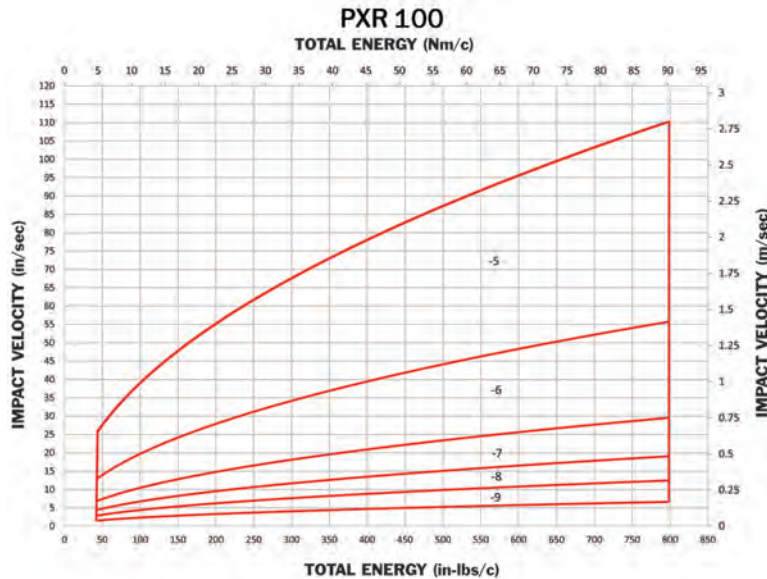
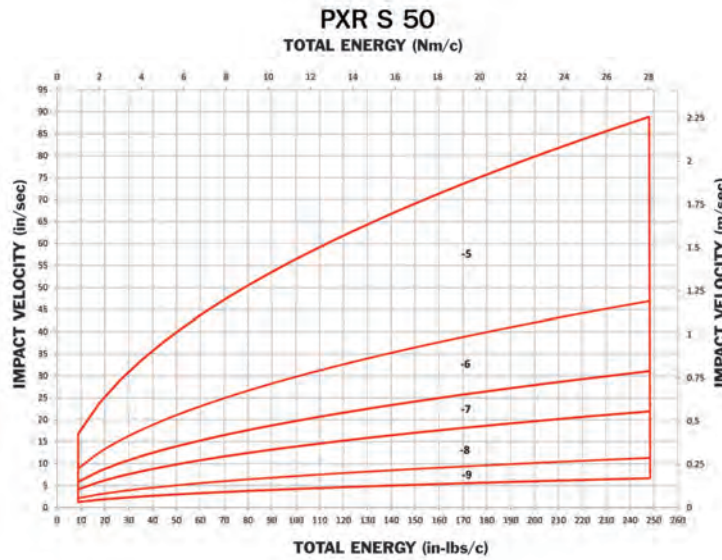
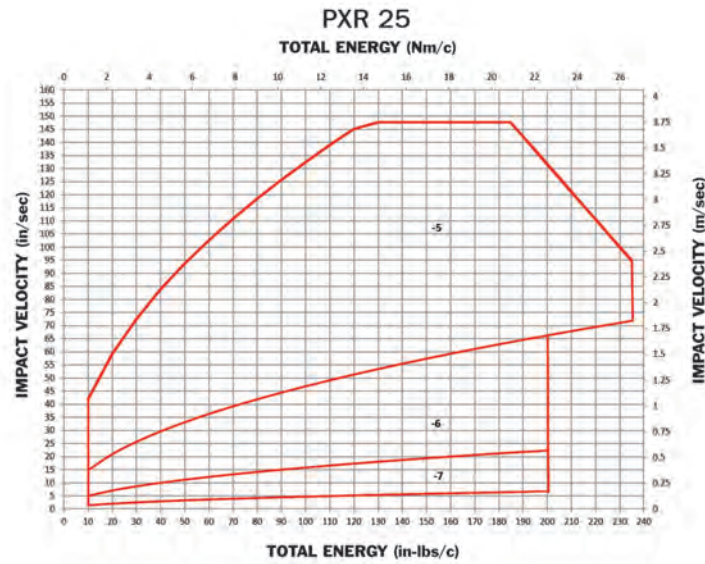

Note: Minimum impact velocity for PXR models is 4 in./sec. (0,1 m/sec).

PXR 25 → PXR 100 Series

### Jam Nut (JN)

\*Note: One Hex Jam Nut included with every shock absorber.

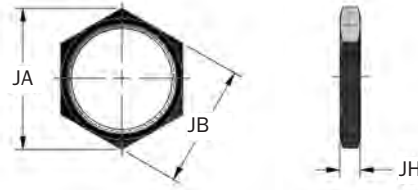

Catalog No./ Model	PXR Series Part Number	Model (Ref)	JA in. (mm)	JB in. (mm)	JH in. (mm)	Weight (mass) oz. (g)
JN 1/2 - 20	J123842166	PXR 25 IF (B)	0.72	0.63	.12	0.1
JN M14 x 1	J223842035	PXR 25 MF (B)	(19,7)	(17,0)	(4,0)	(3)
JN 9/16 - 18	J123842034	PXR 25 IC (B)	1.01	0.88	.31	0.6
JN M14 x 1,5	J223842165	PXR 25 MC (B)	(19,7)	(17,0)	(4,0)	(3)
JN 3/4 - 16	J123844034	PXR S 50 IF (B)	1.08	0.94	.18	0.3
JN M20 x 1,5	J223844035	PXR S 50 MC (B)	(27,7)	(24,0)	(4,6)	(7)
JN 1-12	J123846034	PXR 100 IF (B)	1.30	1.13	.18	0.5
JN M25 x 1,5	J223846035	PXR 100 MF (B)	(37,0)	(32,0)	(4,6)	(15)
JN M27 x 3	J124059034	PXR 100 MC (B)	(37,0)	(32,0)	(4,6)	(15)

### Stop Collar (SC)

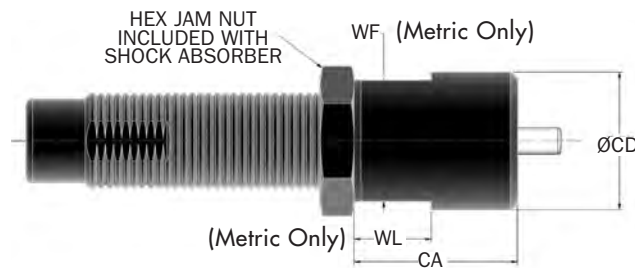

Catalog No./ Model	PXR Series Part Number	Model (Ref)	CA in. (mm)	CD in. (mm)	WF in. (mm)	WL in. (mm)	Weight (mass) oz. (g)
SC 1/2 - 20	M923842057	PXR 25 IF (B)	1.00	0.75	-	-	1.0
SC M14 x 1	M923842058	PXR 25 MF (B)	(25,4)	(21,0)	(19,0)	(12,0)	(38)
SC 9/16 - 18	M923842199	PXR 25 IC (B)	1.00	0.69	-	-	1.0
SC M14 x 1,5	M923842171	PXR 25 MC (B)	(25,4)	(21,0)	(19,0)	(12,0)	(38)
SC 3/4 - 16	M923844057	PXR S 50 IF (B)	1.50	1.00	-	-	2.0
SC M20 x 1,5	M924057058	PXR S 50 MC (B)	(38,0)	(25,0)	(22,0)	(12,0)	(63)
SC 1-12	M923846057	PXR 100 IF (B)	1.75	1.50	-	-	8.0
SC M25 x 1,5	M923846171	PXR 100 MF (B)	(44,5)	(38,0)	(32,0)	(15,0)	(215)
SC M27 x 3	M923846170	PXR 100 MC (B)	(44,5)	(38,0)	(32,0)	(15,0)	(215)



This Page  
Intentionally  
Left Blank



PMXT 1525/2150  
Mid-Bore Series

ITT Enidine non-adjustable hydraulic shock absorbers can accommodate varying energy conditions. This family of tamperproof shock absorbers provides consistent performance, cycle after cycle. Non-adjustable models are designed to absorb maximum energy within a compact envelope size.

The **PM Series** uses a self-compensating design to provide energy absorption in low velocity and high drive force applications. The PM Series also includes the added benefit of corrosion-resistant, nickel-plated components and positive stop capabilities. Models can accommodate a wide range of operating conditions with varying masses or propelling forces.

### Features and Benefits

- Extensive non-adjustable product line offers flexibility in both size and energy absorption capacity to fulfill a wide range of application requirements.
- Tamperproof design ensures repeatable performance.
- Special materials and finishes can be designed to meet specific customer requirements.
- Incorporating optional fluids and seal packages can expand the standard operating temperature range from (15°F to 180°F) to (-30°F to 210°F).
- Threaded cylinders provide mounting flexibility and increase surface area for improved heat dissipation.
- A select variety of surface finishes maintains original quality appearance and provides the longest corrosion resistance protection.
- ISO quality standards result in reliable, long-life operation.

### ITT Enidine Non-Adjustable Multiple Orifice Shock Absorbers

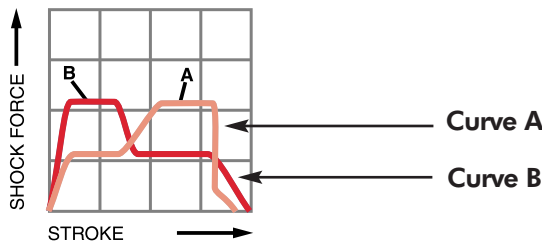
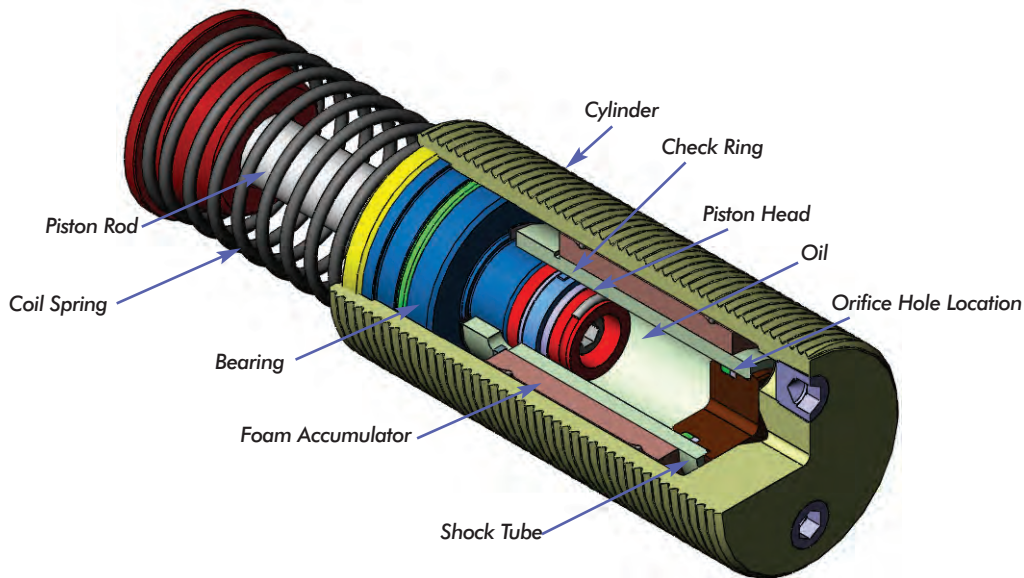

**Self-compensating damping** maintains acceptable deceleration with conventional type damping characteristics. Self-compensating shock absorbers operate over a wide range of weights and velocities. These shock absorbers are well suited for high drive force, low velocity applications, and where energy conditions may change. **Curve A** shows the *shock force vs. stroke* curve of a self-compensating shock absorber impacted with a low velocity and high drive force. **Curve B** shows the *shock force vs. stroke* curve of a self-compensating shock absorber impacted with a high velocity and low drive force.

The design of a multi-orifice shock absorber features a double cylinder arrangement with space between the concentric shock tube and cylinder, and a series of orifice holes drilled down the length of the shock tube wall.

During piston movement, the check ring is seated and oil is forced through the orifices in the shock tube wall, into the closed cellular foam accumulator and behind the piston head.

As the piston head moves it closes off orifice holes, thus reducing the available orifice area in proportion to the velocity. After the load is removed the coil spring pushes the piston rod outward. This unseats the check ring and permits the oil to flow from the accumulator and across the piston head, back into the shock tube. This allows quick repositioning for the next impact.

Low Pressure multiple orifice shock absorbers can provide progressive or self-compensating damping, depending on the impact conditions.

PMXT 1525 → PMXT 2150 Series

### Standard

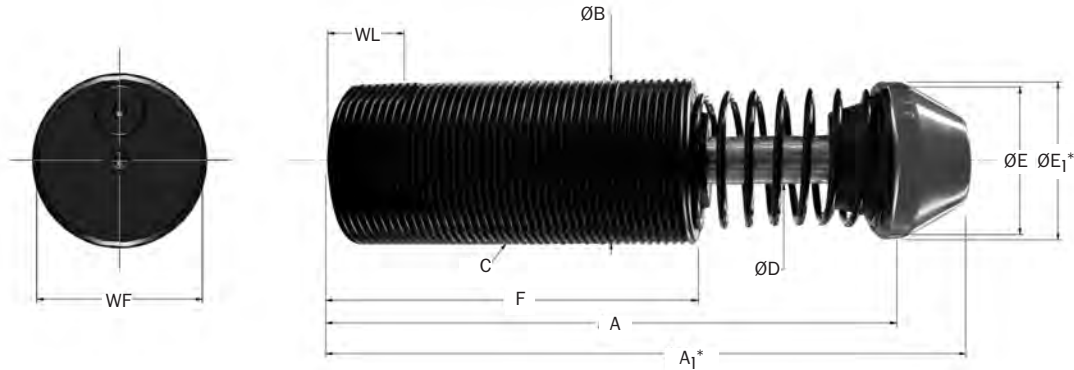

\*Note: A<sub>1</sub> and E<sub>1</sub> apply to button models and urethane striker cap accessory.

Catalog No./ Model	(S) Stroke in. (mm)	(E <sub>T</sub> ) Max. in.-lbs./cycle (Nm/cycle)	(E <sub>T</sub> C) Max. in.-lbs./hour (Nm/h)	(F <sub>P</sub> ) Max. Reaction Force lbs. (N)	Nominal Coil Spring Force		(F <sub>D</sub> ) Max. Propelling Force lbs. (N)	Weight (mass) lbs. (Kg)
					Extended lbs. (N)	Compressed lbs. (N)		
PMXT 1525	1.00 (25,0)	3,250 (367,0)	1,120,000 (126 000)	6,500 (29 000)	11.0 (48,0)	15.0 (68,0)	1,500 (6 700)	2.2 (1,0)
PMXT 1550	2.00 (50,0)	6,500 (735,0)	1,475,000 (167 000)	6,500 (29 000)	11.0 (29,0)	18.0 (78,0)	1,500 (6 700)	2.4 (1,1)
PMXT 1575	3.00 (75,0)	10,000 (1 130,0)	1,775,000 (201 000)	6,500 (29 000)	7.0 (31,0)	18.0 (78,0)	1,500 (6 700)	2.7 (1,3)
PMXT 2050	2.00 (50,0)	16,500 (1 865,0)	2,400,000 (271 000)	13,750 (60 500)	17.0 (80,0)	35.0 (155,0)	4,000 (17 800)	6.0 (2,7)
PMXT 2100	4.00 (100,0)	33,000 (3 729,0)	3,200,000 (362 000)	13,750 (60 500)	16.0 (69,0)	36.0 (160,0)	4,000 (17 800)	7.3 (3,3)
PMXT 2150	6.00 (150,0)	50,000 (5 650,0)	3,730,000 (421 000)	13,750 (60 500)	20.0 (87,0)	64.0 (285,0)	4,000 (17 800)	9.3 (4,2)

Catalog No./ Model	Damping Constant	A in. (mm)	A <sub>1</sub> in. (mm)	C in. (mm)	D in. (mm)	E in. (mm)	E <sub>1</sub> in. (mm)	F in. (mm)	WF in. (mm)	WL in. (mm)
PMXT 1525 IF	-1,-2,-3	5.68	6.37	(IF) 1 3/4-12 UN	.50	1.48	1.75	3.63	1.70	0.75
PMXT 1525 MF	-1,-2,-3	(144,0)	(162,0)	(MF) M45 x 1,5	(12,7)	(38,0)	(44,5)	(92,0)	(43,5)	(19,0)
PMXT 1550 IF	-1,-2,-3	7.68	8.37	(IF) 1 3/4-12 UN	.50	1.48	1.75	4.63	1.70	0.75
PMXT 1550 MF	-1,-2,-3	(195,0)	(213,0)	(MF) M45 x 1,5	(12,7)	(38,0)	(44,5)	(118,0)	(43,5)	(19,0)
PMXT 1575 IF	-1,-2,-3	9.68	10.37	(IF) 1 3/4-12 UN	.50	1.48	1.75	5.63	1.70	0.75
PMXT 1575 MF	-1,-2,-3	(246,0)	(264,0)	(MF) M45 x 1,5	(12,7)	(38,0)	(44,5)	(143,0)	(43,5)	(19,0)
PMXT 2050 IF	-1,-2,-3	8.90	9.55	(IF) 2 1/2-12 UN	.75	1.98	2.25	5.50	2.42	0.75
PMXT 2050 MF	-1,-2,-3	(226,0)	(243,0)	(MF) M64 x 2,0	(19,0)	(50,0)	(57,0)	(140,0)	(61,5)	(19,0)
PMXT 2100 IF	-1,-2,-3	12.90	13.55	(IF) 2 1/2-12 UN	.75	1.98	2.25	7.50	2.42	0.75
PMXT 2100 MF	-1,-2,-3	(328,0)	(345,0)	(MF) M64 x 2,0	(19,0)	(50,0)	(57,0)	(191,0)	(61,5)	(19,0)
PMXT 2150 IF	-1,-2,-3	17.97	18.62	(IF) 2 1/2-12 UN	.75	2.38	2.38	9.50	2.42	0.75
PMXT 2150 MF	-1,-2,-3	(956,0)	(473,0)	(MF) M64 x 2,0	(19,0)	(60,0)	(60,0)	(241,0)	(61,5)	(19,0)

Notes: 1. Dash numbers in page color are non-standard lead time items, contact ITT Enidine.  
 2. See page 59 for constant damping curves.  
 3. Urethane striker caps are available as accessories for models PM 1525 to PM 2150.

# Non-Adjustable Series Hydraulic Shock Absorbers

## PMXT Mid-Bore Series

### Accessories

PMXT 1525 CM → PMXT 2150 CM Series

### Clevis Mount

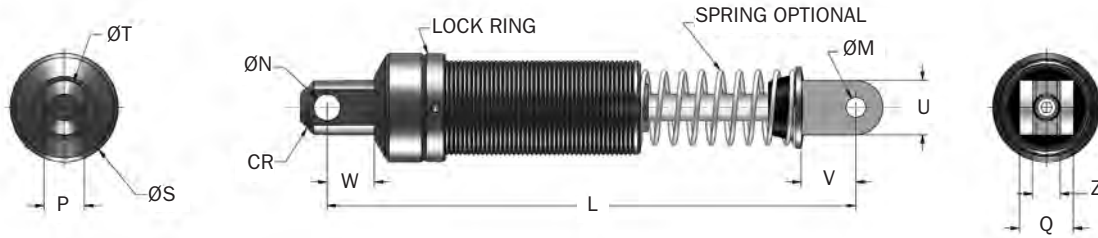

Catalog No./ Model	L in. (mm)	M +.005/-0.000 (+0,13/-0,00) in. (mm)	N +.005/-0.000 (+0,13/-0,00) in. (mm)	P +.000/-0.010 (+0,00/-0,25) in. (mm)	Q +.000/-0.010 (+0,00/-0,25) in. (mm)	S in. (mm)	T in. (mm)	U in. (mm)	V in. (mm)	W in. (mm)	Z +.020/-0.000 (+0,51/-0,00) in. (mm)	CR in. (mm)	Weight (mass) lbs. (Kg)
Δ PMXT 1525 CM (S)	7.84 (199)	.376 (9,60)	.501 (12,70)	.750 (19,00)	1.00 (25,4)	2.00 (51)	1.00 (25)	1.00 (25)	1.01 (26)	.87 (22)	.505 (12,9)	.56 (14,3)	3.0 (1,36)
Δ PMXT 1550 CM (S)	9.84 (250)	.376 (9,60)	.501 (12,70)	.750 (19,00)	1.00 (25,4)	2.00 (51)	1.00 (25)	1.00 (25)	1.01 (26)	.87 (22)	.505 (12,9)	.56 (14,3)	3.2 (1,45)
Δ PMXT 1575 CM (S)	11.84 (300)	.376 (9,60)	.501 (12,70)	.750 (19,00)	1.00 (25,4)	2.00 (51)	1.00 (25)	1.00 (25)	1.01 (26)	.87 (22)	.505 (12,9)	.56 (14,3)	3.6 (1,63)
Δ PMXT 2050 CM (S)	12.06 (306)	.751 (19,07)	.751 (19,07)	1.250 (31,70)	1.50 (38,0)	2.88 (73)	1.50 (38)	1.50 (38)	1.40 (35)	1.06 (26)	.630 (16,0)	.90 (23,0)	8.2 (3,72)
Δ PMXT 2100 CM (S)	16.06 (408)	.751 (19,07)	.751 (19,07)	1.250 (31,70)	1.50 (38,0)	2.88 (73)	1.50 (38)	1.50 (38)	1.40 (35)	1.06 (26)	.630 (16,0)	.90 (23,0)	9.3 (4,22)
Δ PMXT 2150 CM (S)	21.13 (537)	.751 (19,07)	.751 (19,07)	1.250 (31,70)	1.50 (38,0)	2.88 (73)	1.50 (38)	1.50 (38)	1.40 (35)	1.06 (26)	.630 (16,0)	.90 (23,0)	11.2 (5,08)

Notes: 1. Δ = Non-standard lead time items, contact ITT Enidine.  
2. (S) indicates model comes with spring.

### Flange Foot Mount

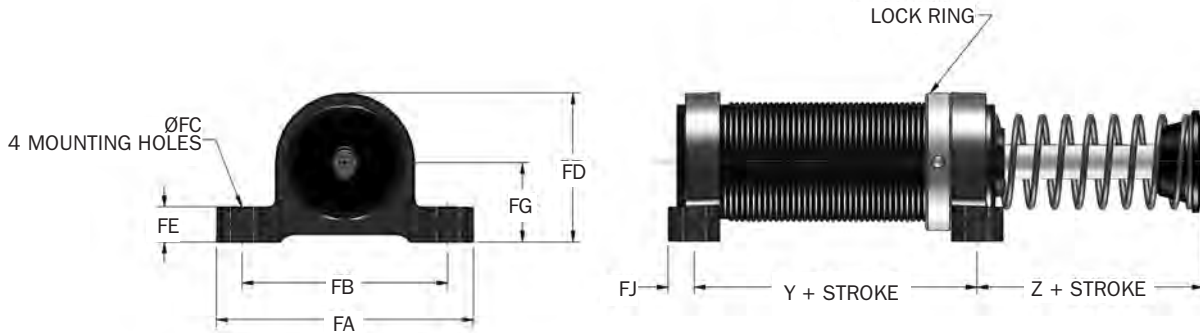

Catalog No./ Model	Part Number	Model (Ref)	Y in. (mm)	Z in. (mm)	FA in. (mm)	FB in. (mm)	FC in. (mm)	FD in. (mm)	FE in. (mm)	FG in. (mm)	FJ in. (mm)	Bolt Size in. (mm)	Kit Weight oz. (g)	Notes
FM 1 3/4 - 12	2FE2740	PMXT 1500 Series	2.38 (60,5)	1.06 (26,9)	3.75 (95,3)	3.00 (76,2)	.34 (8,60)	2.16 (55,0)	.50 (12,7)	1.16 (29,5)	.38 (9,7)	5/16	12.0 oz. (370)	3
FM M45 x 1,5	2F8637	PMXT 1500M Series										M8		3
FM 2 1/2 - 12	2FE3010	PMXXT 2000 Series	3.00 (76,2)	1.56 (39,6)	5.63 (143,0)	4.88 (124,0)	.41 (10,40)	3.38 (85,6)	.63 (16,0)	1.75 (44,5)	.44 (11,2)	3/8	2.3 lbs. (1 050)	1,3
FM M64 x 2	2F3010	PMXT 2000M Series										M10		1,3

Notes: 1. PM 2150 Z dimension is 2.69 in.  
2. Shock absorber must be ordered separately from foot mount kit.  
3. All foot mount kits include two foot mounts and lock ring.

PMXT 1525 → PMXT 2150 Series

Non-Adjustable Series

### Stop Collar (SC)



Catalog No./ Model	Part Number	Model (Ref)	CA in. (mm)	CD in. (mm)	Weight (mass) oz. (g)
SC 1 3/4 - 12	8KE2940	PMXT 1500 Series	1.94	2.22	12.0
SC M45 x 1,5	8K8637	PMXT 1500M Series	(49,0)	(56,5)	(340)
SC 2 1/2 - 12 x 2	8KE3010	PMXT 2050 / 2100 Series	2.47	3.00	23.0
SC M64 x 2 x 2	M93010057	PMXT 2050M Series	(89,0)	(76,0)	(936)
SC 2 1/2 - 12 x 6	8KE3012	PMXT 2150 Series	3.66	3.00	35.0
SC M64 x 2 x 4	M93011057	PMXT 2100M Series	(114,0)	(76,0)	(1 191)
SC M64 x 2 x 6	M93012057	PMXT 2150M Series	(143,0)	(76,0)	(1 475)

Note: 1. Part numbers in page color are non-standard lead time items, contact ITT Enidine.

### Urethane Striker Cap (USC)

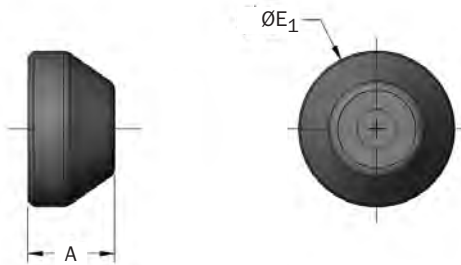

Catalog No./ Model	Part Number	Model (Ref)	A in. (mm)	E1 in. (mm)	Weight (mass) oz. (g)
UC 2940	C92940079	PMXT 1500	.97 (24,5)	1.75 (44,5)	0.5 (14)
UC 3010	C93010079	PMXT 2000	.95 (24,0)	2.25 (57,0)	0.8 (23)

### Lock Ring (LR)

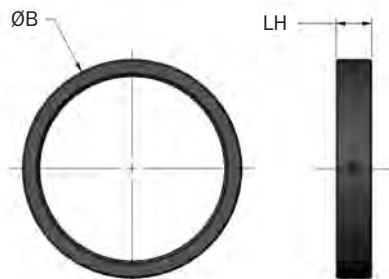

Catalog No./Model	Part Number	Model (Ref)	B in. (mm)	LH in. (mm)	Weight (mass) oz. (g)
LR 1 3/4 - 12	F8E2940049	PMXT 1500 Series	2.00	.38	2.0
LR M45 x 1,5	F88637049	PMXT 1500M Series	(57,2)	(9,5)	(75)
LR 2 1/2 - 12	F8E3010049	PMXT 2000 Series	2.88	.38	3.0
LR M64 x 2	F83010049	PMXT 2000M Series	(72,9)	(12,7)	(85)

# Non-Adjustable Series Hydraulic Shock Absorbers

## PMXT Mid-Bore Series

PMXT 1525 CM → PMXT 2150 CM Series

Accessories

Non-Adjustable Series

### Square Flange (SF)

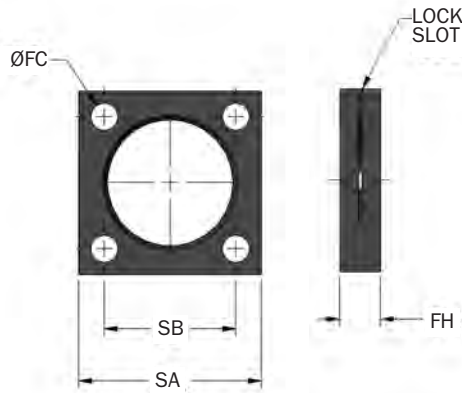

Catalog No./ Model	Part Number	Model (Ref)	FC in. (mm)	FH in. (mm)	SA in. (mm)	SB in. (mm)	Bolt Size in. (mm)	Weight (mass) oz. (g)
SF 1 3/4 - 12	M4E2940056	PMXT 1500 Series	.34 (8,6)	.50 (12,7)	2.25 (57,2)	1.63 (41,3)	5/16 (M8)	5 (140)
SF M45 x 1,5	M48637056	PMXT 1500M Series	.41 (10,4)	.62 (15,7)	3.50 (85,1)	2.75 (69,9)	3/8 (M10)	20 (570)

### Rectangular Flange (RF)

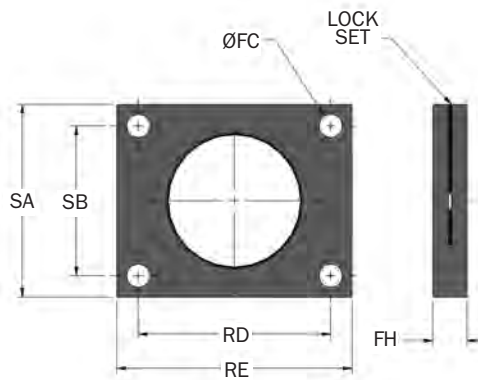

Catalog No./ Model	Part Number	FC Model (Ref)	FH in. (mm)	RD in. (mm)	RE in. (mm)	SA in. (mm)	SB in. (mm)	Size in. (mm)	Bolt (mass) in. (mm)	Wt. oz. (g)
RF 1 3/4 - 12	M5E2940053	PMXT 1500 Series	.34 (8,6)	.50 (12,7)	2.38 (60,5)	3.00 (76,2)	2.25 (57,2)	1.63 (41,4)	5/16 (M8)	9 (260)
RF M45 x 1,5	M58637053	PMXT 1500M Series	.41 (10,4)	.62 (15,7)	3.50 (85,1)	4.13 (105,1)	2.75 (69,9)	3/8 (M10)		

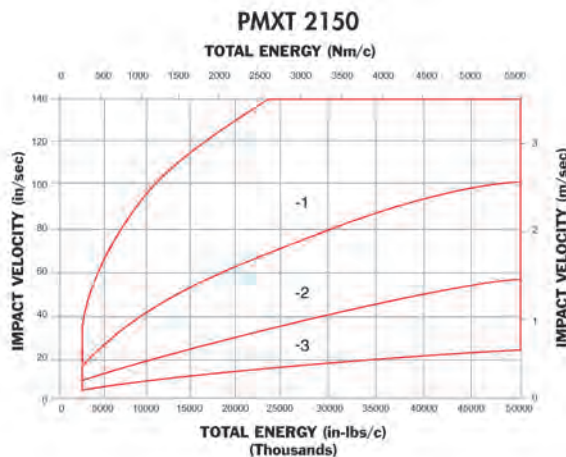
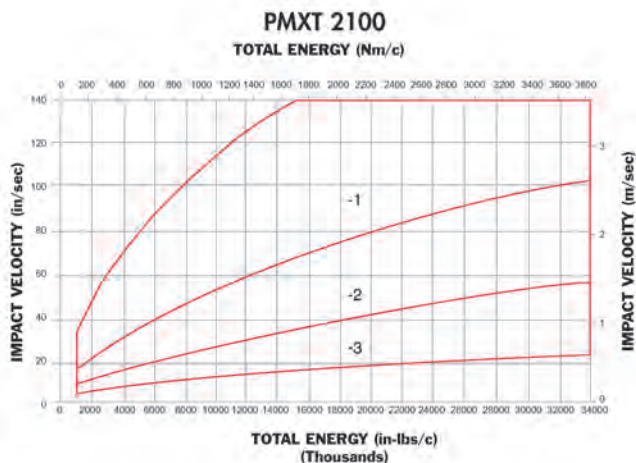
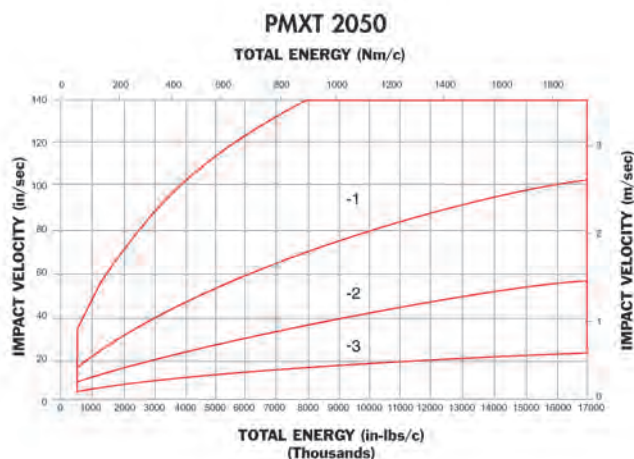
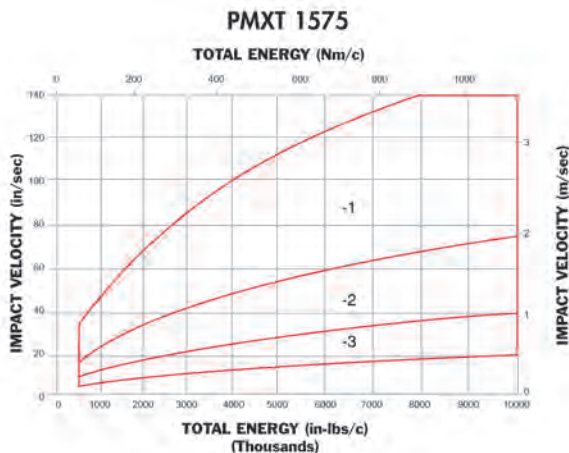
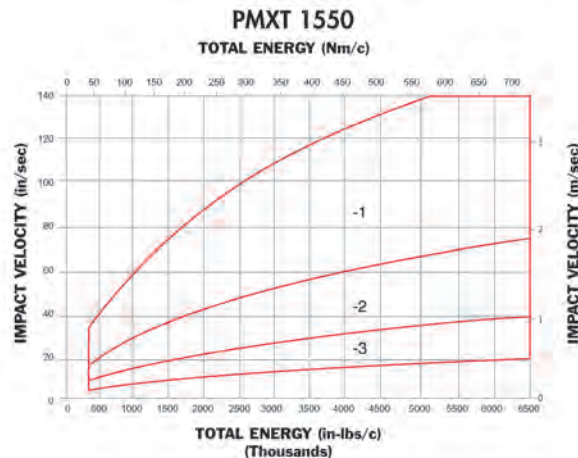
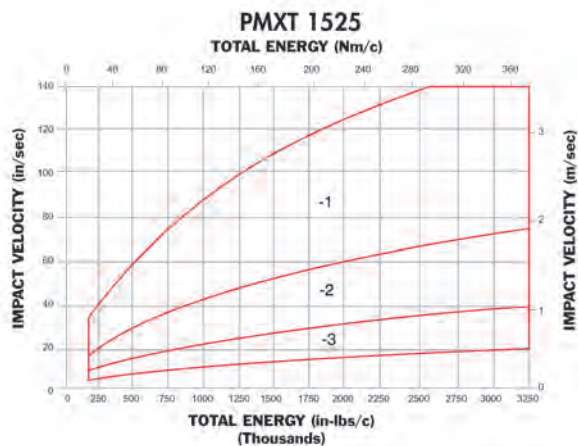

Note: Minimum impact velocity for PM models is 4 in./sec. (0,1 m/sec).



### Typical Applications

Non-Adjustable Series



*Automated Handling*



*Conveyor Systems*

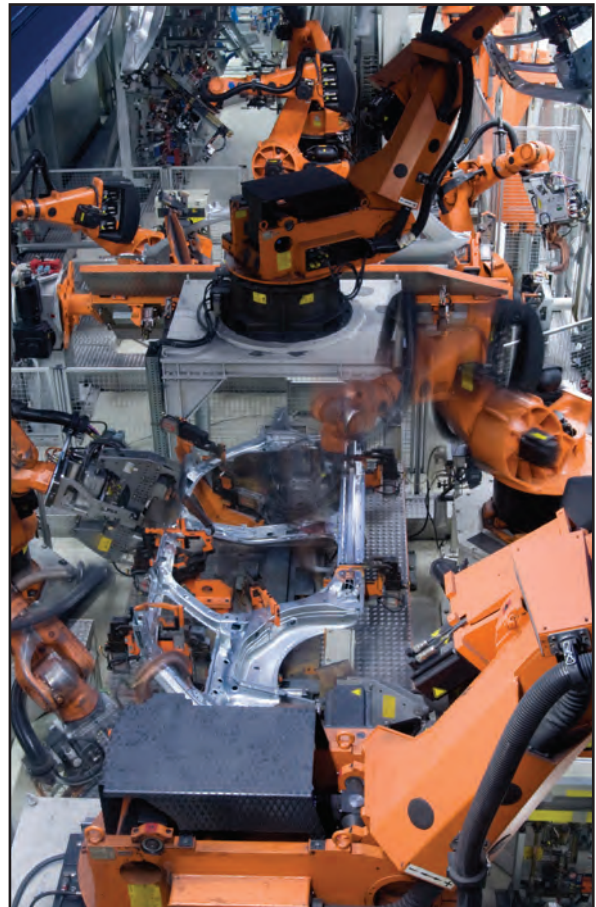

*Robotics*

ITT Enidine Heavy Duty Series large-bore hydraulic shock absorbers protect equipment from large impacts in applications such as automated storage and retrieval systems, as well as overhead bridge and trolley cranes. They are available in a wide variety of stroke lengths and damping characteristics to increase equipment life and meet stringent deceleration requirements.

### HDN Series

Custom-orificed design accommodates specified damping requirements. Computer generated output performance simulation is used to optimize the orifice configuration. Available in standard bore dimensions of up to 4 in. (100mm) and strokes over 60 in. (1524mm).

### HDA Series

Adjustable units enable the user to modify shock absorber resistance to accommodate load velocity variations, with strokes up to 12in. (305mm). Standard adjustable configurations available.



## Features and Benefits HDN, HDA

- Designed with Environmentally friendly materials and fluids
- Compact design smoothly and safely decelerates large energy capacity loads up to 3,000,000 in-lbs. per cycle (330 000 Nm)
- Internal charged air/oil accumulator replaces mechanical return springs, providing shorter overall length and reduced weight.  
**Optional** Bladder Accumulator (BA) for higher cycle rates also available.
- Engineered to meet OSHA, AISE, CMAA and other safety specifications such as DIN and FEM.
- Wide variety of optional configurations including bellows, clevis mounts and safety cables.
- Painted external components provide excellent corrosion protection.
- Epoxy painting and special rod materials are available for use in highly corrosive environments.
- All sizes are fully field repairable.
- Piston rod extension sensor systems available for re-use safety requirements.
- Incorporating optional fluids and seal packages can expand standard operating temperature range from 15°F to 140°F (-10°C to 60°C) to -30°F to 210°F (-35°C to 100°C)

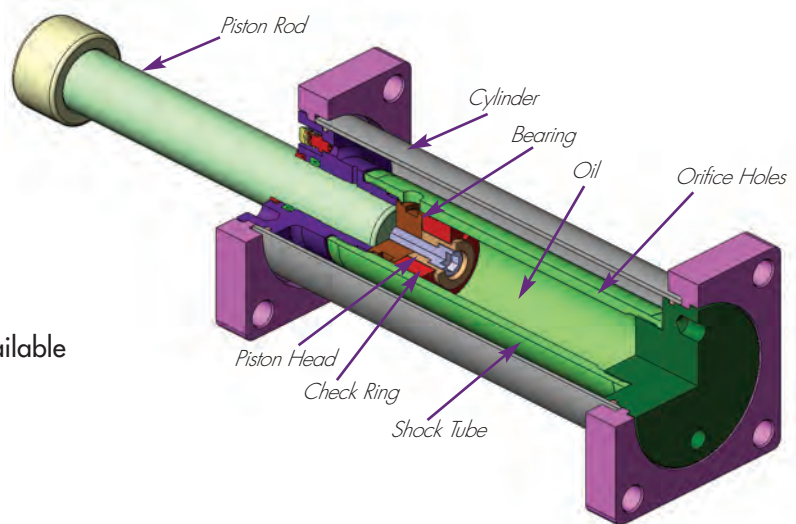

# Heavy Duty Shock Absorbers

## HDN 1.5 Series

### Technical Data

HDN 1.5 x 2 → HDN 1.5 x 32 Series

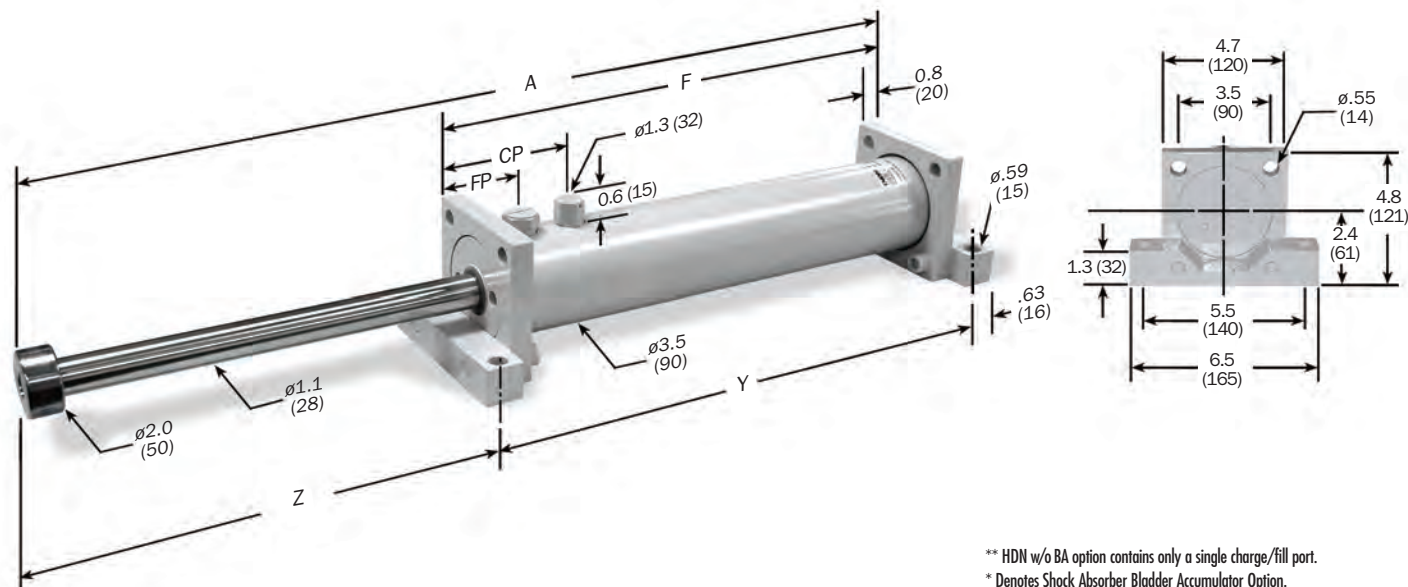

Dimensions are in inches (millimeters).

\*\* HDN w/o BA option contains only a single charge/fill port.  
\* Denotes Shock Absorber Bladder Accumulator Option.  
Note: For TF, FF and FR mounting, delete front foot and dimensions.

Catalog No./ Model	(S) Stroke in. (mm)	(E <sub>T</sub> ) Max. in.-lbs./cycle (Nm/cycle)	(E <sub>T</sub> C) Max. in.-lbs./hour (Nm/hr)	(F <sub>P</sub> ) Max. Shock Force lbs. (N)	Nominal Return Force BA*	Nominal Return Force w/o BA*	A in. (mm)	F in. (mm)	Y in. (mm)	Z in. (mm)	With BA		CP** w/o BA* in. (mm)	Model Weight lbs. (Kg)
											CP BA* in. (mm)	FP BA* in. (mm)		
HDN 1.5 x 2	2 (50)	27,900 (3 200)	1,676,000 (189 000)	15,750 (70 060)	50 (220)	70 (320)	12.2 (310)	8.2 (208)	9.4 (240)	3.4 (86)	5.5 (139)	3.4 (86)	1.6 (41)	22 (10)
HDN 1.5 x 4	4 (100)	54,200 (6 100)	3,257,300 (368 000)	15,750 (70 060)	50 (220)	90 (410)	16.1 (410)	10.2 (258)	11.4 (290)	5.4 (136)	5.5 (139)	3.4 (86)	1.6 (41)	24 (12)
HDN 1.5 x 6	6 (150)	80,600 (9 100)	4,838,500 (546 700)	15,750 (70 060)	50 (220)	100 (450)	20.1 (510)	12.1 (308)	13.4 (340)	7.3 (186)	5.5 (139)	3.4 (86)	1.6 (41)	26 (12)
HDN 1.5 x 8	8 (200)	108,000 (12 200)	6,482,900 (732 500)	15,750 (70 060)	50 (220)	120 (525)	24.1 (613)	14.2 (360)	15.4 (392)	9.3 (237)	5.5 (139)	3.4 (86)	1.6 (41)	29 (13)
HDN 1.5 x 10	10 (250)	134,900 (15 200)	6,912,000 (781 000)	15,750 (70 060)	50 (220)	135 (600)	28.2 (715)	16.2 (411)	17.4 (443)	11.3 (288)	5.5 (139)	3.4 (86)	1.6 (41)	31 (14)
HDN 1.5 x 12	12 (300)	161,800 (18 300)	7,769,700 (877,900)	15,750 (70 060)	50 (220)	210 (920)	32.2 (817)	18.2 (462)	19.4 (494)	13.3 (339)	5.5 (139)	3.4 (86)	1.6 (41)	35 (16)
HDN 1.5 x 14	14 (350)	185,100 (20 900)	8,610,500 (972,900)	15,750 (70 060)	50 (220)	250 (1 120)	36.1 (918)	20.2 (512)	21.4 (544)	15.4 (390)	5.5 (139)	3.4 (86)	1.6 (41)	37 (17)
HDN 1.5 x 16	16 (400)	208,300 (23 300)	9,468,200 (1 069 800)	13,500 (60 060)	50 (220)	250 (1 120)	40.1 (1 019)	22.2 (563)	23.4 (595)	17.3 (440)	5.5 (139)	3.4 (86)	1.6 (41)	40 (18)
HDN 1.5 x 18	18 (450)	224,300 (25 300)	10,325,900 (1 166 700)	10,750 (47 820)	50 (220)	250 (1 120)	44.1 (1 121)	24.2 (614)	25.4 (646)	19.3 (491)	5.5 (139)	3.4 (86)	1.6 (41)	42 (19)
HDN 1.5 x 20	20 (500)	240,300 (27 200)	11,183,600 (1 263 600)	8,750 (38 920)	50 (220)	250 (1 120)	48.2 (1 223)	26.2 (665)	27.4 (697)	21.4 (542)	5.5 (139)	3.4 (86)	1.6 (41)	44 (20)
HDN 1.5 x 24	24 (600)	269,600 (30 500)	12,899,000 (1 457 400)	6,250 (27 800)	50 (220)	250 (1 120)	56.2 (1 427)	30.2 (767)	31.5 (799)	21.3 (644)	5.5 (139)	3.4 (86)	1.6 (41)	50 (23)
HDN 1.5 x 28	28 (713)	297,000 (33 600)	14,597,600 (1 649 300)	4,750 (21,130)	50 (220)	250 (1 120)	64.1 (1 629)	34.2 (868)	35.4 (900)	29.3 (745)	5.5 (139)	3.4 (86)	1.6 (41)	56 (25)
HDN 1.5 x 32	32 (813)	322,800 (36 500)	16,279,300 (1 839 300)	3,700 (16 460)	50 (220)	250 (1 120)	72.0 (1 830)	38.1 (968)	39.4 (1 000)	33.3 (846)	5.5 (139)	3.4 (86)	1.6 (41)	62 (28)

Notes: 1. HDN shock absorbers will function satisfactorily at 5% of their maximum rated energy per cycle. If less than these values, a smaller model should be specified.

- It is recommended that the customer consult ITT Enidine for safety-related overhead crane applications.
- The energy data listed is for ideal linear impacts only. If side load conditions exist in the application, contact ITT Enidine for sizing assistance.
- Rear flange mounting of 12 inch (300 mm) strokes and longer not recommended. Front and rear flange or foot mount configurations are recommended.
- Maximum cycle rate is 60 cycles/hr. for HDN with BA (Bladder Accumulator) option and 30 cycles/hr. without BA option.
- For impact velocities over 180 in./sec. (4.5 m/s), consult factory.

# Heavy Duty Series Shock Absorber

## HDN 2.0 Series

### Technical Data

HDN 2.0 x 6 → HDN 2.0 x 56 Series

**Heavy Duty Series**

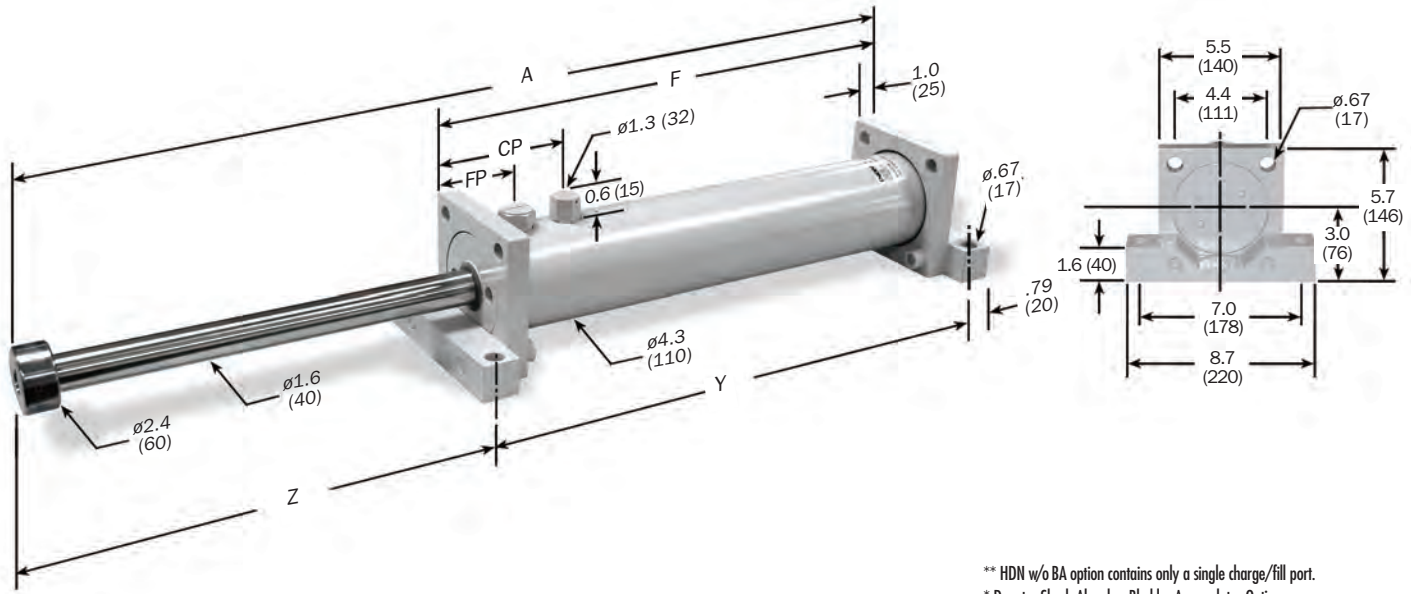

Dimensions are in inches (millimeters).

\*\* HDN w/o BA option contains only a single charge/fill port.  
\* Denotes Shock Absorber Bladder Accumulator Option.  
Note: For TF, FF and FR mounting, delete front foot and dimensions.

Catalog No./ Model	(S) Stroke in. (mm)	(E <sub>T</sub> ) Max. in.-lbs./cycle (Nm/cycle)	(E <sub>T-C</sub> ) Max. in.-lbs./hour (Nm/hr)	(F <sub>p</sub> ) Max. Shock Force lbs. (N)	Nominal Return Force BA* lbs. (N)	Nominal Return Force w/o BA* lbs. (N)	A in. (mm)	F in. (mm)	Y in. (mm)	Z in. (mm)	With BA		CP** w/o BA* in. (mm)	Model Weight lbs. (Kg)
											CP BA* in. (mm)	FP BA* in. (mm)		
HDN 2.0 x 6	6 (152)	127,200 (14 400)	7,629,900 (862 100)	25,000 (111 200)	120 (535)	200 (870)	21.8 (553)	13.3 (339)	14.9 (379)	7.6 (194)	6.9 (176)	3.8 (96)	1.8 (46)	42 (19)
HDN 2.0 x 8	8 (203)	169,800 (19 200)	8,086,900 (913 700)	25,000 (111 200)	120 (535)	235 (1 040)	25.8 (655)	15.4 (390)	16.9 (430)	9.6 (245)	6.9 (176)	3.8 (96)	1.8 (46)	46 (20)
HDN 2.0 x 10	10 (250)	212,500 (24 000)	9,144,400 (1 033 200)	25,000 (111 200)	120 (535)	300 (1 340)	29.8 (757)	17.4 (441)	18.9 (481)	11.7 (296)	6.9 (176)	3.8 (96)	1.8 (46)	51 (23)
HDN 2.0 x 12	12 (300)	253,200 (28 600)	10,201,900 (1 152 700)	25,000 (111 200)	120 (535)	515 (2 290)	33.8 (859)	19.4 (492)	20.9 (532)	13.7 (347)	6.9 (176)	3.8 (96)	1.8 (46)	55 (25)
HDN 2.0 x 14	14 (350)	285,900 (32 300)	11,259,500 (1 272 100)	25,000 (111 200)	120 (535)	515 (2 290)	37.8 (960)	21.4 (543)	23.0 (583)	15.6 (397)	6.9 (176)	3.8 (96)	1.8 (46)	60 (27)
HDN 2.0 x 16	16 (400)	318,700 (36 000)	12,317,000 (1 391 600)	25,000 (111 200)	120 (535)	515 (2 290)	41.8 (1 062)	23.4 (594)	25.0 (634)	17.6 (448)	6.9 (176)	3.8 (96)	1.8 (46)	64 (29)
HDN 2.0 x 18	18 (450)	351,500 (39 700)	13,374,500 (1 511 100)	25,000 (111 200)	120 (535)	515 (2 290)	45.8 (1 164)	25.4 (645)	27.0 (685)	19.6 (499)	6.9 (176)	3.8 (96)	1.8 (46)	68 (31)
HDN 2.0 x 20	20 (500)	383,600 (43 300)	14,411,300 (1 628 300)	25,000 (111 200)	120 (535)	515 (2 290)	49.8 (1 265)	27.4 (695)	28.9 (735)	21.7 (550)	6.9 (176)	3.8 (96)	1.8 (46)	73 (33)
HDN 2.0 x 24	24 (600)	449,100 (50 700)	16,526,300 (1 867 200)	25,000 (111 200)	120 (535)	515 (2 290)	57.8 (1 469)	31.4 (797)	33.0 (837)	25.7 (652)	6.9 (176)	3.8 (96)	1.8 (46)	79 (36)
HDN 2.0 x 28	28 (700)	514,678 (58 200)	18,641,400 (2 106 200)	25,000 (111 200)	120 (535)	515 (2 290)	65.8 (1 672)	35.4 (899)	37.0 (939)	29.6 (753)	6.9 (176)	3.8 (96)	1.8 (46)	93 (42)
HDN 2.0 x 32	32 (800)	625,600 (70 700)	22,373,800 (2 527 900)	25,000 (111 200)	120 (535)	515 (2 290)	76.9 (1 953)	42.5 (1 079)	44.1 (1 119)	33.6 (854)	10.1 (256)	6.9 (176)	1.8 (46)	108 (49)
HDN 2.0 x 36	36 (900)	689,500 (77 900)	24,447,300 (2 762 200)	22,500 (100 000)	120 (535)	515 (2 290)	84.7 (2 151)	46.4 (1 179)	48.0 (1 219)	37.5 (952)	10.1 (256)	6.9 (176)	1.8 (46)	117 (53)
HDN 2.0 x 40	40 (1 000)	746,700 (84,400)	26,520,900 (2 996 500)	19,000 (84 500)	120 (535)	515 (2 290)	92.6 (2 351)	50.4 (1 279)	51.9 (1 319)	41.4 (1 052)	10.1 (256)	6.9 (176)	1.8 (46)	124 (56)
HDN 2.0 x 48	48 (1 200)	844,100 (95 400)	30,668,000 (3 465 000)	13,500 (60 000)	120 (535)	515 (2 290)	108.3 (2 751)	58.2 (1 479)	59.8 (1 519)	49.3 (1 252)	10.1 (256)	6.9 (176)	1.8 (46)	141 (64)
HDN 2.0 x 56	56 (1 400)	922,300 (104 200)	35,022,500 (3 957 000)	7,900 (35 100)	120 (535)	515 (2 290)	124.8 (3 171)	66.5 (1 689)	68.1 (1 729)	57.6 (1 462)	10.1/38.4** (256/975)	6.9 (176)	1.8 (46)	161 (73)

- Notes: 1. HDN shock absorbers will function satisfactorily at 5% of their maximum rated energy per cycle. If less than these values, a smaller model should be specified.
- 2. It is recommended that the customer consult ITT Enidine for safety-related overhead crane applications.
- 3. The energy data listed is for ideal linear impacts only. If side load conditions exist in the application, contact ITT Enidine for sizing assistance.
- 4. Rear flange mounting of 12 inch (300 mm) strokes and longer not recommended. Front and rear flange or foot mount configurations are recommended.
- 5. Maximum cycle rate is 60 cycles/hr. for HDN with BA (Bladder Accumulator) option and 30 cycles/hr. without BA option.
- 6. For impact velocities over 180 in./sec. (4.5 m/s), consult factory.
- 7. \*\* HDN 2.0 x 56 has two charge ports.

# Heavy Duty Series Shock Absorber

## HDN 3.0 Series

HDN 3.0 x 2 → HDN 3.0 x 60 Series

### Technical Data

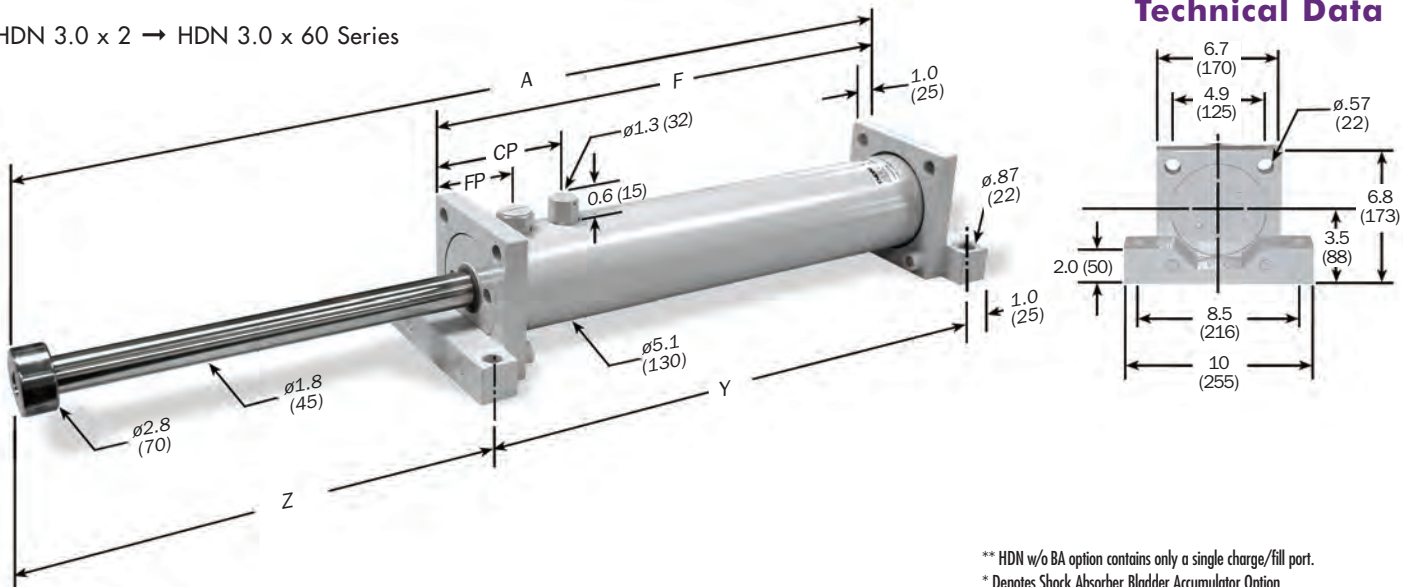

Dimensions are in inches (millimeters).

\*\* HDN w/o BA option contains only a single charge/fill port.  
\* Denotes Shock Absorber Bladder Accumulator Option.  
Note: For TE, FF and FR mounting, delete front foot and dimensions.

Catalog No./ Model	(S) Stroke in. (mm)	(E <sub>T</sub> ) Max. in.-lbs./cycle (Nm/cycle)	(E <sub>T-C</sub> ) Max. in.-lbs./hour (Nm/hr)	(F <sub>P</sub> ) Max. Initial Shock Force lbs. (N)	Nominal Return Force BA* lbs. (N)	Nominal Return Force w/o BA* lbs. (N)	A in. (mm)	F in. (mm)	Y in. (mm)	Z in. (mm)	With BA		CP** w/o BA* in. (mm)	Model Weight lbs. (Kg)
											CP BA* in. (mm)	FP BA* in. (mm)		
HDN 3.0 x 2	2 (50)	85,300 (9 600)	5,120,100 (578 500)	50,000 (222 400)	150 (670)	255 (1 130)	13.2 (336)	8.0 (203)	10.0 (253)	4.3 (108)	5.0 (128)	2.4 (61)	1.8 (46)	40 (21)
HDN 3.0 x 3	3 (75)	128,800 (14 600)	5,832,300 (659 000)	50,000 (222 400)	160 (710)	405 (1 810)	15.2 (387)	9.0 (229)	11.0 (279)	5.2 (133)	5.0 (128)	2.4 (61)	1.8 (46)	42 (22)
HDN 3.0 x 5	5 (125)	214,200 (24 200)	7,131,200 (805 700)	50,000 (222 400)	165 (735)	650 (2 895)	19.3 (489)	11.0 (280)	13.0 (330)	7.2 (184)	5.0 (128)	2.4 (61)	1.8 (46)	48 (25)
HDN 3.0 x 8	8 (200)	316,100 (35 700)	9,041,400 (1 021 500)	50,000 (222 400)	170 (755)	650 (2 895)	25.2 (640)	14.0 (355)	15.9 (405)	10.2 (260)	5.0 (128)	2.4 (61)	1.8 (46)	57 (29)
HDN 3.0 x 10	10 (250)	382,600 (43 200)	10,340,300 (1 168 300)	50,000 (222 400)	175 (780)	650 (2 895)	29.2 (742)	16.0 (406)	18.0 (456)	12.2 (311)	5.0 (128)	2.4 (61)	1.8 (46)	64 (32)
HDN 3.0 x 12	12 (300)	449,100 (50 700)	11,639,200 (1 315 000)	50,000 (222 400)	175 (780)	650 (2 895)	33.2 (844)	18.0 (457)	20.0 (507)	14.3 (362)	5.0 (128)	2.4 (61)	1.8 (46)	71 (35)
HDN 3.0 x 14	14 (350)	556,500 (62 900)	14,211,500 (1 605 700)	50,000 (222 400)	180 (800)	650 (2 895)	39.2 (995)	22.0 (558)	23.9 (608)	16.2 (412)	7.0 (178)	4.4 (111)	1.8 (46)	88 (43)
HDN 3.0 x 16	16 (400)	623,000 (70 400)	15,510,400 (1 752 400)	50,000 (222 400)	180 (800)	650 (2 895)	43.2 (1 097)	24.0 (609)	25.9 (659)	18.2 (463)	7.0 (178)	4.4 (111)	1.8 (46)	93 (45)
HDN 3.0 x 18	18 (450)	689,400 (77 900)	16,809,300 (1 899 200)	50,000 (222 400)	180 (800)	650 (2 895)	47.2 (1 199)	26.0 (660)	28.0 (710)	20.2 (514)	7.0 (178)	4.4 (111)	1.8 (46)	99 (48)
HDN 3.0 x 20	20 (500)	755,900 (85 400)	18,108,200 (2 046 000)	50,000 (222 400)	180 (800)	650 (2 895)	51.2 (1 301)	28.0 (711)	30.0 (761)	22.2 (565)	7.0 (178)	4.4 (111)	1.8 (46)	106 (51)
HDN 3.0 x 24	24 (600)	887,600 (100 300)	20,680,500 (2 336 600)	50,000 (222 400)	180 (800)	650 (2 895)	59.2 (1 504)	32.0 (812)	33.9 (862)	26.3 (667)	7.0 (178)	4.4 (111)	1.8 (46)	119 (57)
HDN 3.0 x 28	28 (700)	1,020,600 (115 300)	23,278,300 (2 630 100)	50,000 (222 400)	180 (800)	650 (2 895)	67.2 (1 707)	36.0 (914)	38.0 (964)	30.2 (768)	7.0 (178)	4.4 (111)	1.8 (46)	130 (62)
HDN 3.0 x 32	32 (800)	1,152,200 (130 200)	25,850,700 (2 920 700)	40,500 (180 200)	180 (800)	650 (2 895)	75.2 (1 910)	40.0 (1 015)	41.9 (1 065)	34.3 (870)	7.0 (178)	6.3 (161)	1.8 (46)	143 (68)
HDN 3.0 x 36	36 (900)	1,307,100 (147 700)	29,645,500 (3 349 500)	36,000 (160 100)	180 (800)	650 (2 895)	84.9 (2 156)	45.8 (1 164)	47.8 (1 214)	38.1 (967)	9.0 (228)	6.3 (161)	1.8 (46)	163 (77)
HDN 3.0 x 40	40 (1 000)	1,412,700 (159 600)	32,192,300 (3 637 200)	31,500 (140 000)	180 (800)	650 (2 895)	92.8 (2 356)	49.8 (1 264)	51.7 (1 314)	42.0 (1 067)	9.0 (228)	6.3 (161)	1.8 (46)	176 (85)
HDN 3.0 x 48	48 (1 200)	1,590,700 (179 700)	37,286,100 (4 212 800)	21,500 (95 600)	185 (825)	650 (2 895)	108.5 (2 756)	57.6 (1 464)	59.6 (1 514)	49.9 (1 267)	9.0 (228)	6.3 (161)	1.8 (46)	200 (94)
HDN 3.0 x 56	56 (1 400)	1,741,300 (196 700)	42,379,800 (4 788 300)	12,500 (55 600)	185 (825)	650 (2 895)	124.3 (3 156)	65.5 (1 664)	67.5 (1 714)	57.8 (1 467)	9.0/37.3** (228)/(947)	6.3 (161)	1.8 (46)	235 (106)
HDN 3.0 x 60	60 (1 500)	1,830,400 (206 800)	45,283,200 (5 116 300)	11,950 (53 200)	185 (825)	650 (2 895)	133.2 (3 384)	70.0 (1 778)	72.0 (1 828)	62.2 (1 581)	9.0/39.5** (228)/(1004)	6.3 (161)	1.8 (46)	235 (106)
HDN 3.0 x 64	64 (1 629)	1,921,500 (217 100)	46,116,000 (5 210 400)	11,950 (53 200)	185 (825)	650 (2 895)	145.2 (3 688)	78.0 (1 980)	79.9 (2 030)	66.3 (1 683)	12.9/60.1 (328)/(1 527)	10.2 (260)	1.8 (46)	245 (110)
HDN 3.0 x 72	72 (1 830)	2,106,500 (238 000)	55,245,000 (6 242 000)	11,950 (53 200)	185 (825)	650 (2 895)	158.0 (4 012)	82.5 (2 092)	84.5 (2 142)	74.6 (1 895)	17.3/68.0 (439)/(1 727)	10.2 (260)	1.8 (46)	260 (118)

Notes: 1. HDN shock absorbers will function satisfactorily at 5% of their maximum rated energy per cycle. If less than these values, a smaller model should be specified.  
2. It is recommended that the customer consult ITT Enidine for safety-related overhead crane applications.  
3. The energy data listed is for ideal linear impacts only. If side load conditions exist in the application, contact ITT Enidine for sizing assistance.  
4. Rear flange mounting of 12 inch (300 mm) strokes and longer not recommended. Front and rear flange or foot mount configurations are recommended.  
5. Maximum cycle rate is 60 cycles/hr. for HDN with BA option and 30 cycles/hr. without BA (Bladder Accumulator) option.  
6. For impact velocities over 180 in./sec. (4.5 m/s), consult factory.  
7. \*\* HDN 3.0 x 56 and HDN 3.0 x 60 have 2 charge ports.

# Heavy Duty Series Shock Absorber

## HDN 3.5 Series

### Technical Data

HDN 3.5 x 2 → HDN 3.5 x 56 Series

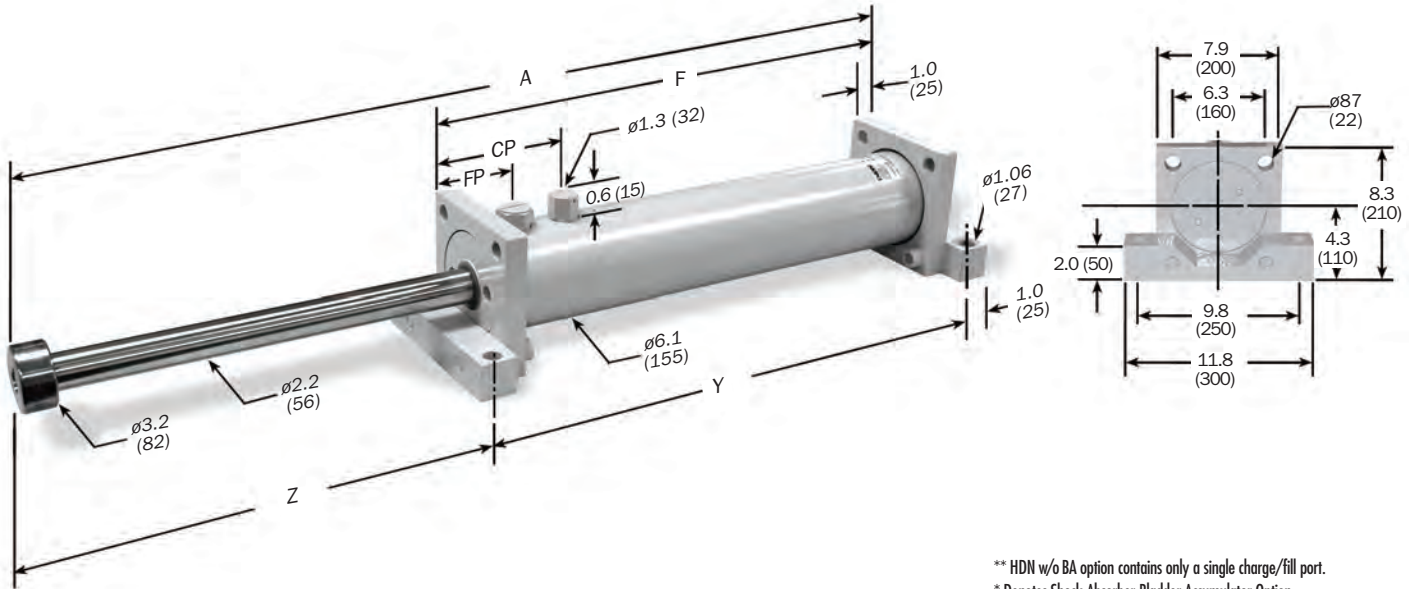

Dimensions are in inches (millimeters).

\*\* HDN w/o BA option contains only a single charge/fill port.  
 \* Denotes Shock Absorber Bladder Accumulator Option.  
 Note: For TF, FF and FR mounting, delete front foot and dimensions.

Catalog No./ Model	(S) Stroke in. (mm)	(E <sub>T</sub> ) Max. in.-lbs./cycle (Nm/cycle)	(E <sub>T-C</sub> ) Max. in.-lbs./hour (Nm/hr)	(F <sub>p</sub> ) Max. Shock Force lbs. (N)	Nominal Return Force BA* lbs. (N)	Nominal Return Force w/o BA* lbs. (N)	A in. (mm)	F in. (mm)	Y in. (mm)	Z in. (mm)	With BA		CP** w/o BA* in. (mm)	Model Weight lbs. (Kg)
											CP BA* in. (mm)	FP BA* in. (mm)		
HDN 3.5 x 2	2 (50)	115,200 (13 000)	6,912,100 (781 000)	67,500 (300 250)	215 (960)	455 (2 020)	13.9 (354)	9.6 (244)	11.6 (294)	3.3 (85)	5.3 (134)	3.0 (77)	2.1 (52)	73 (33)
HDN 3.5 x 4	4 (100)	230,400 (26 000)	8,793,200 (993 500)	67,500 (300 250)	230 (1 020)	610 (2 710)	18.0 (456)	11.6 (295)	13.6 (345)	5.4 (136)	5.3 (134)	3.0 (77)	2.1 (52)	82 (37)
HDN 3.5 x 6	6 (150)	343,300 (38 800)	10,283,600 (1 161 900)	67,500 (300 250)	260 (1 160)	1,010 (4 480)	21.9 (556)	13.6 (345)	15.6 (395)	7.3 (186)	5.3 (134)	3.0 (77)	2.1 (52)	90 (41)
HDN 3.5 x 8	8 (200)	450,300 (50 900)	11,803,800 (1 333 600)	67,500 (300 250)	265 (1 180)	1,010 (4 480)	25.9 (658)	15.6 (396)	17.6 (446)	9.3 (237)	5.3 (134)	3.0 (77)	2.1 (52)	99 (45)
HDN 3.5 x 10	10 (250)	538,400 (60 800)	13,324,000 (1 505 400)	67,500 (300 250)	270 (1 200)	1,010 (4 480)	29.9 (760)	17.6 (447)	19.6 (497)	11.3 (288)	5.3 (134)	3.0 (77)	2.1 (52)	108 (49)
HDN 3.5 x 12	12 (300)	626,500 (70 800)	14,844,100 (1 677 200)	67,500 (300 250)	270 (1 200)	1,010 (4 480)	33.9 (862)	19.6 (498)	21.6 (548)	13.3 (339)	5.3 (134)	3.0 (77)	2.1 (52)	117 (53)
HDN 3.5 x 16	16 (400)	801,000 (90 500)	17,854,700 (2 017 300)	67,500 (300 250)	275 (1 225)	1,010 (4 480)	41.9 (1 064)	23.6 (599)	25.6 (649)	17.3 (440)	5.3 (134)	3.0 (77)	2.1 (52)	132 (60)
HDN 3.5 x 20	20 (500)	1,051,800 (118 800)	22,534,500 (2 546 100)	67,500 (300 250)	275 (1 225)	1,010 (4 480)	52.0 (1 323)	29.8 (756)	31.8 (806)	21.2 (542)	7.4 (189)	5.2 (132)	2.1 (52)	163 (74)
HDN 3.5 x 24	24 (600)	1,228,000 (138 700)	25,574,800 (2 889 600)	67,500 (300 250)	280 (1 250)	1,010 (4 480)	60.1 (1 527)	33.8 (858)	35.8 (908)	25.3 (644)	7.4 (189)	5.2 (132)	2.1 (52)	179 (81)
HDN 3.5 x 28	28 (700)	1,402,500 (158 500)	28,585,400 (3 229 700)	67,500 (300 250)	280 (1 250)	1,010 (4 480)	68.0 (1 729)	37.8 (959)	39.8 (1 009)	29.2 (745)	7.4 (189)	5.2 (132)	2.1 (52)	196 (89)
HDN 3.5 x 32	32 (800)	1,578,700 (178 400)	31,625,800 (3 573 200)	67,500 (300 250)	280 (1 250)	1,010 (4 480)	76.1 (1 933)	41.8 (1 061)	43.8 (1 111)	33.2 (847)	7.4 (189)	5.2 (132)	2.1 (52)	214 (97)
HDN 3.5 x 36	36 (900)	1,754,900 (198 300)	34,666,100 (3 916 800)	58,500 (260 200)	280 (1 250)	1,010 (4 480)	84.1 (2 137)	45.8 (1 163)	47.8 (1 213)	37.3 (949)	7.4 (189)	5.2 (132)	2.1 (52)	231 (105)
HDN 3.5 x 40	40 (1 000)	1,918,600 (216 800)	37,676,700 (4 256 900)	48,500 (215 700)	280 (1 250)	1,010 (4 480)	92.1 (2 339)	49.8 (1 264)	51.8 (1 314)	41.3 (1 050)	7.4 (189)	5.2 (132)	2.1 (52)	247 (112)
HDN 3.5 x 48	48 (1 200)	2,188,000 (247 200)	43,638,200 (4 930 500)	35,000 (155 700)	280 (1 250)	1,010 (4 480)	107.8 (2 739)	57.6 (1 464)	59.6 (1 514)	49.2 (1 250)	7.4 (189)	5.2 (132)	2.1 (52)	282 (128)
HDN 3.5 x 56	56 (1 400)	2,418,600 (273 300)	49,599,700 (5 604 000)	25,300 (112 500)	470 (2 100)	1,010 (4 480)	123.6 (3 139)	65.5 (1 665)	67.5 (1 715)	57.1 (1 450)	7.4/48.6** (1 894)/(1 233)	5.2 (132)	2.1 (52)	317 (144)

- Notes: 1. HDN shock absorbers will function satisfactorily at 5% of their maximum rated energy per cycle. If less than these values, a smaller model should be specified.  
 2. It is recommended that the customer consult ITT Enidine for safety-related overhead crane applications.  
 3. The energy data listed is for ideal linear impacts only. If side load conditions exist in the application, contact ITT Enidine for sizing assistance.  
 4. Rear flange mounting of 12 inch (300 mm) strokes and longer not recommended. Front and rear flange or foot mount configurations are recommended.  
 5. Maximum cycle rate is 60 cycles/hr. for HDN with BA option and 30 cycles/hr. without BA option.  
 6. For impact velocities over 180 in./sec. (4.5 m/s), consult factory.  
 7. \*\* HDN 3.5 x 56 has two charge ports.

# Heavy Duty Series Shock Absorber

## HDN 4.0 Series

### Technical Data

HDN 4.0 x 2 → HDN 4.0 x 48 Series

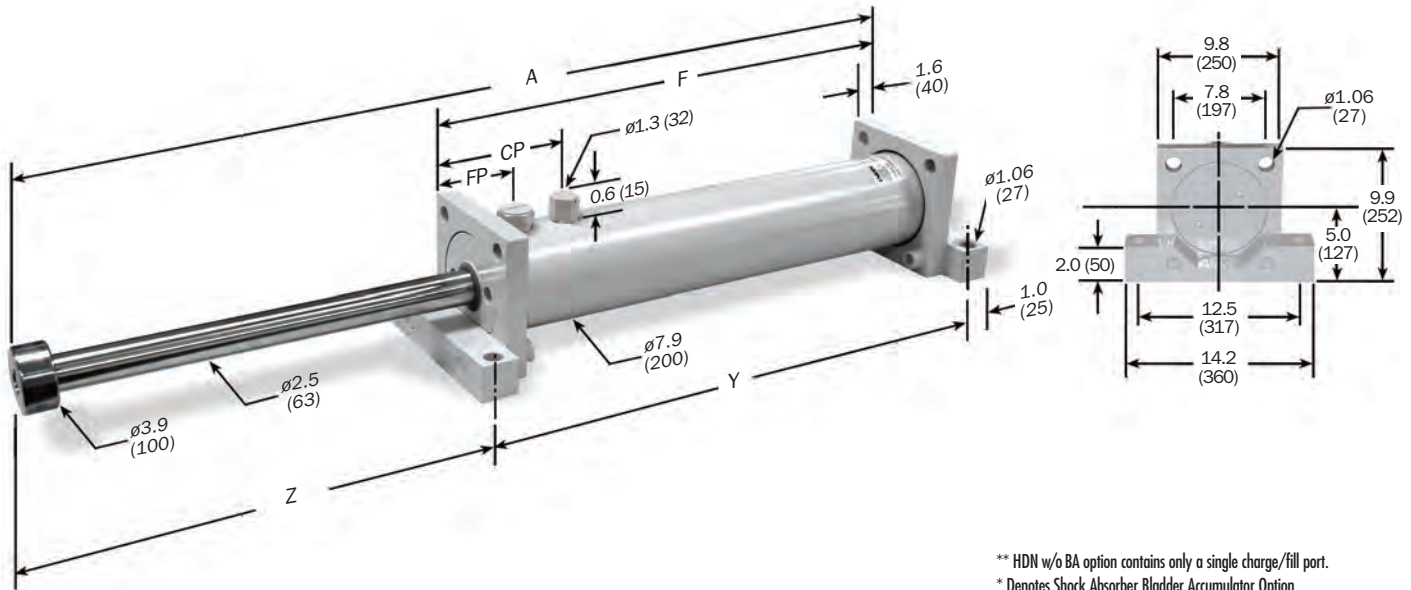

Dimensions are in inches (millimeters).

\*\* HDN w/o BA option contains only a single charge/fill port.  
\* Denotes Shock Absorber Bladder Accumulator Option.  
Note: For TF, FF and FR mounting, delete front foot and dimensions.

Catalog No./ Model	(S) Stroke in. (mm)	(E <sub>T</sub> ) Max. in.-lbs./cycle (Nm/cycle)	(E <sub>T</sub> C) Max. in.-lbs./hour (Nm/hr)	(F <sub>P</sub> ) Max. Initial Shock Force lbs. (N)	Nominal Return Force BA* lbs. (N)	Nominal Return Force w/o BA* lbs. (N)	A in. (mm)	F in. (mm)	Y in. (mm)	Z in. (mm)	With BA			Model Weight lbs. (Kg)
											CP BA* in. (mm)	FP BA* in. (mm)	CP** w/o BA* in. (mm)	
HDN 4.0 x 2	2 (50)	139,200 (15 700)	8,352,800 (943 700)	80,000 (355 900)	250 (1 100)	425 (1 900)	16.9 (430)	11.6 (294)	13.5 (344)	4.4 (111)	8.1 (206)	4.3 (108)	2.5 (64)	141 (64)
HDN 4.0 x 4	4 (100)	275,700 (31 200)	13,579,600 (1 534 300)	80,000 (355 900)	270 (1 200)	485 (2 160)	20.9 (532)	13.6 (345)	15.6 (395)	6.4 (162)	8.1 (206)	4.3 (108)	2.5 (64)	154 (70)
HDN 4.0 x 6	6 (150)	409,606 (46 279)	15,547,700 (1 756 700)	80,000 (355 900)	270 (1 200)	690 (3 050)	24.9 (632)	15.6 (395)	17.5 (445)	8.3 (212)	8.1 (206)	4.3 (108)	2.5 (64)	168 (76)
HDN 4.0 x 8	8 (200)	548,800 (62 000)	17,594,400 (1 987 900)	80,000 (355 900)	270 (1 200)	980 (4 370)	28.9 (735)	17.6 (447)	19.6 (497)	10.4 (263)	8.1 (206)	4.3 (108)	2.5 (64)	181 (82)
HDN 4.0 x 10	10 (250)	682,700 (77 100)	19,562,500 (2 210 300)	80,000 (355 900)	270 (1 200)	1,230 (5 465)	32.9 (836)	19.6 (497)	21.5 (547)	12.4 (314)	8.1 (206)	4.3 (108)	2.5 (64)	192 (87)
HDN 4.0 x 12	12 (300)	819,200 (92 600)	25,269,900 (1 855 100)	80,000 (355 900)	275 (1 225)	1,000 (4 440)	40.6 (1 032)	25.3 (642)	27.2 (692)	14.4 (365)	11.8 (300)	8.0 (202)	2.5 (64)	238 (108)
HDN 4.0 x 16	16 (400)	1,089,600 (123 100)	29,245,400 (3 304 300)	80,000 (355 900)	275 (1 225)	1,270 (5 650)	48.6 (1 234)	29.3 (743)	31.2 (793)	18.3 (466)	11.8 (300)	8.0 (202)	2.5 (64)	265 (120)
HDN 4.0 x 20	20 (500)	1,362,700 (154 000)	33,260,200 (3 757 900)	80,000 (355 900)	280 (1 245)	1,155 (5 145)	56.6 (1 438)	33.3 (845)	35.2 (895)	22.4 (568)	11.8 (300)	8.0 (202)	2.5 (64)	290 (131)
HDN 4.0 x 24	24 (600)	1,635,700 (184 800)	37,275,000 (4 211 500)	80,000 (355 900)	280 (1 245)	1,275 (5 675)	64.6 (1 642)	37.3 (947)	39.3 (997)	26.4 (670)	11.8 (300)	8.0 (202)	2.5 (64)	317 (144)
HDN 4.0 x 28	28 (700)	1,904,200 (215 100)	41,250,500 (4 660 700)	80,000 (355 900)	280 (1 245)	1,275 (5 675)	72.6 (1 844)	41.3 (1 048)	43.2 (1 098)	30.4 (771)	11.8 (300)	8.0 (202)	2.5 (64)	346 (157)
HDN 4.0 x 32	32 (800)	2,128,700 (240 500)	45,265,400 (5 114 300)	80,000 (355 900)	280 (1 245)	1,275 (5 675)	80.6 (2 048)	45.3 (1 150)	47.2 (1 200)	34.4 (873)	11.8 (300)	8.0 (202)	2.5 (64)	375 (170)
HDN 4.0 x 36	36 (900)	2,353,200 (265 900)	49,280,200 (5 567 900)	80,000 (355 900)	280 (1 245)	1,275 (5 675)	88.7 (2 252)	49.3 (1 252)	51.3 (1 302)	38.4 (975)	11.8 (300)	8.0 (202)	2.5 (64)	403 (183)
HDN 4.0 x 40	40 (1 000)	2,566,000 (289 900)	53,255,700 (6 017 100)	80,000 (355 900)	280 (1 245)	1,275 (5 675)	96.6 (2 454)	53.3 (1 353)	55.2 (1 403)	42.4 (1 076)	11.8 (300)	8.0 (202)	2.5 (64)	430 (195)
HDN 4.0 x 48	48 (1 200)	2,914,200 (329 300)	61,246,000 (6 919 900)	45,000 (200 000)	280 (1 245)	1,275 (5 675)	112.4 (2 854)	61.3 (1 556)	63.2 (1 606)	50.1 (1 273)	11.8 (300)	8.0 (202)	2.5 (64)	485 (220)

- Notes: 1. HDN shock absorbers will function satisfactorily at 5% of their maximum rated energy per cycle. If less than these values, a smaller model should be specified.  
 2. It is recommended that the customer consult ITT Enidine for safety-related overhead crane applications.  
 3. The energy data listed is for ideal linear impacts only. If side load conditions exist in the application, contact ITT Enidine for sizing assistance.  
 4. Rear flange mounting of 12 inch (300 mm) strokes and longer not recommended. Front and rear flange or foot mount configurations are recommended.  
 5. Maximum cycle rate is 60 cycles/hr. for HDN with BA option and 30 cycles/hr. without BA option.  
 6. For impact velocities over 180 in./sec. (4.5 m/s), consult factory.

# Heavy Duty Adjustable Series Shock Absorber

## HDA 3.0 Series

### Technical Data

HDA 3.0 x 2 → HDA 3.0 x 12 Series

Heavy Duty Series

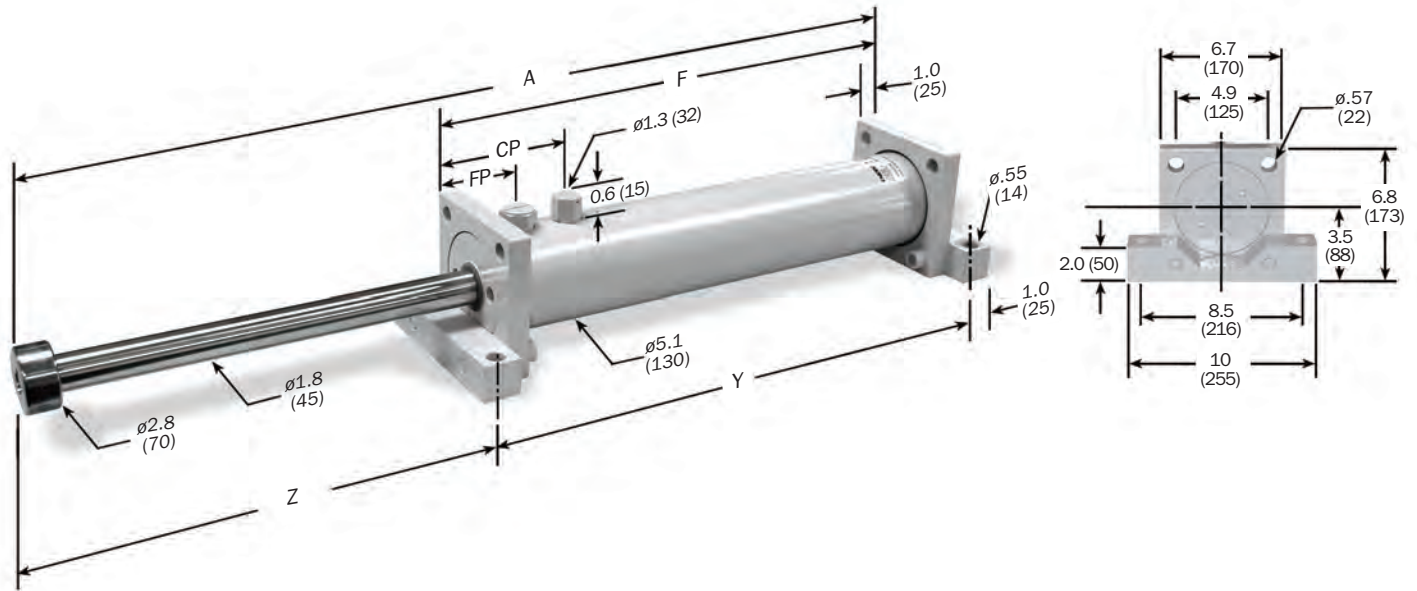

Dimensions are in inches (millimeters).

Note: For TF, FF and FR mounting, delete front foot and dimensions.

Catalog No./ Model	(S) Stroke in. (mm)	(E <sub>T</sub> ) Max. in.-lbs./cycle (Nm/cycle)	(E <sub>T</sub> C) Max. in.-lbs./hour (Nm/hr)	(F <sub>P</sub> ) Max. End Shock Force lbs. (N)	Nominal Return Force BA* lbs. (N)	A in. (mm)	F in. (mm)	Y in. (mm)	Z in. (mm)	With BA		Model Weight lbs. (Kg)
										CP* in. (mm)	FP* in. (mm)	
HDA 3.0 x 2	2 (50)	40,000 (4 500)	2,400,000 (271 200)	50,000 (222 400)	150 (660)	13.2 (336)	8.4 (213)	10.4 (263)	3.9 (98)	4.4 (112)	2.4 (61)	40 (21)
HDA 3.0 x 3	3 (75)	60,000 (6 800)	3,600,000 (406 700)	50,000 (222 400)	160 (710)	15.2 (387)	9.4 (239)	11.4 (289)	4.8 (123)	4.4 (112)	2.4 (61)	42 (22)
HDA 3.0 x 5	5 (125)	100,000 (11 300)	6,000,000 (677 900)	50,000 (222 400)	165 (730)	19.3 (489)	11.4 (290)	13.4 (340)	6.9 (174)	4.4 (112)	2.4 (61)	48 (25)
HDA 3.0 x 8	8 (200)	160,000 (18 100)	9,296,000 (1 050 300)	50,000 (222 400)	170 (765)	25.2 (640)	14.4 (365)	16.3 (415)	9.8 (250)	4.4 (112)	2.4 (61)	57 (29)
HDA 3.0 x 10	10 (250)	200,000 (22 600)	10,594,500 (1 197 100)	50,000 (222 400)	175 (775)	29.2 (742)	16.4 (416)	18.3 (466)	11.9 (301)	4.4 (112)	2.4 (61)	64 (32)
HDA 3.0 x 12	12 (300)	240,000 (27 200)	11,893,800 (1 343 800)	50,000 (222 400)	175 (775)	33.2 (844)	18.4 (467)	20.4 (517)	13.8 (352)	4.4 (112)	2.4 (61)	71 (35)

- Notes:
- HDA shock absorbers will function satisfactorily at 5% of their maximum rated energy per cycle. If less than these values, a smaller model should be specified.
  - It is recommended that the customer consult ITT Enidine for safety-related overhead crane applications.
  - The energy data listed is for ideal linear impacts only. If side load conditions exist in the application, contact ITT Enidine for sizing assistance.
  - Rear flange mounting of 12 inch (300 mm) strokes and longer not recommended. Front and rear flange or foot mount configurations are recommended.
  - Maximum cycle rate is 60 cycles/hr.
  - HDA models which have an impact velocity below 30 in./sec. (.8 m/sec.), please contact ITT Enidine for assistance.
  - Maximum allowable applied propelling force: 25,000 lbs. (111 200 N)

## Adjustment Techniques

### Useable Adjustment Setting Range

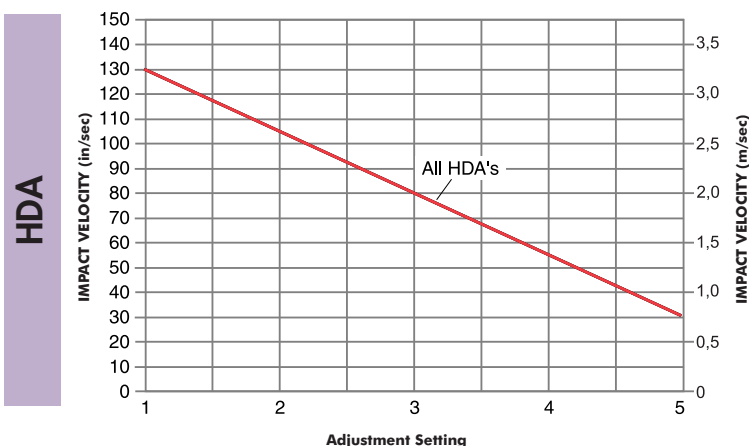

After properly sizing an HDA shock absorber, the useable range of adjustment settings can be determined:

- Locate the intersection point of the application's impact velocity and the HDA model graph line.
- The intersection is the maximum adjustment setting to be used. Adjustments exceeding this setting could overload the shock absorber.
- The useable adjustment setting range is from setting 1 to the MAXIMUM adjustment setting as determined in step 2.

#### EXAMPLE: HDA Series

- Impact Velocity: 80 in./sec. (2 m/s)
- Intersection Point: Adjustment Setting 3
- Useable Adjustment Setting Range: 1 to 3



# Heavy Duty Adjustable Series Shock Absorber

## HDA 4.0 Series

HDA 4.0 x 2 → HDA 4.0 x 10 Series

### Technical Data

Heavy Duty Series

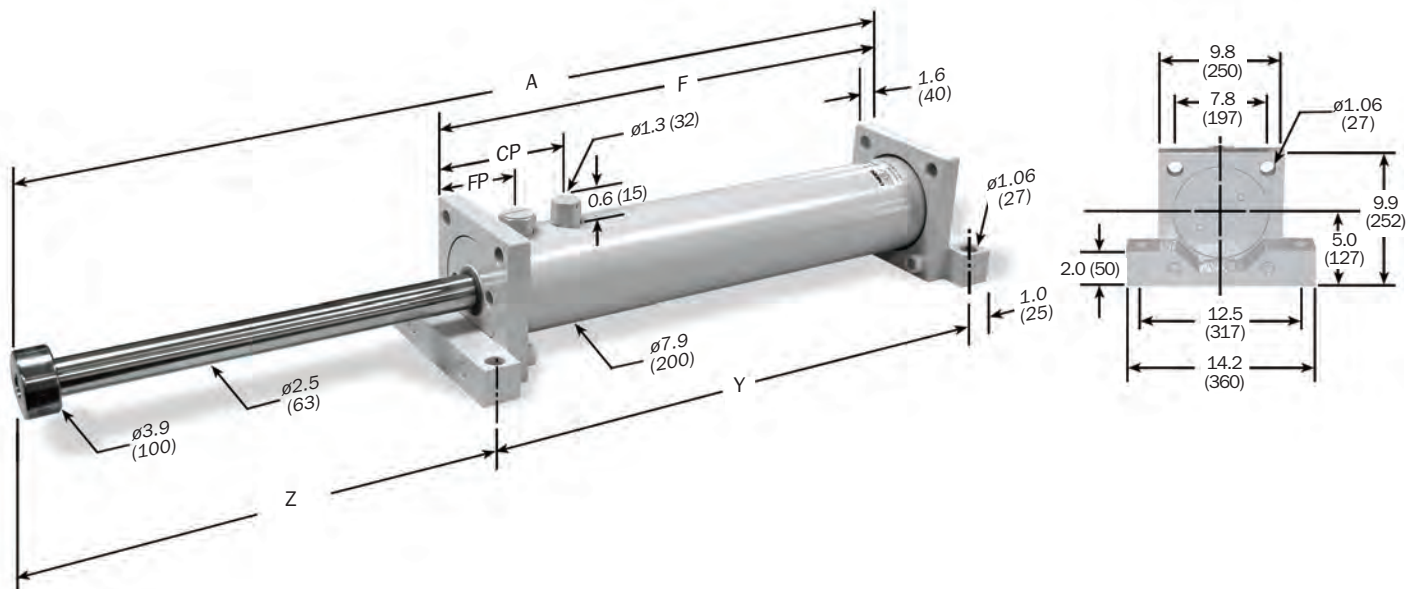

Dimensions are in inches (millimeters).

Note: For TF, FF and FR mounting, delete front foot and dimensions.

Catalog No./ Model	(S) Stroke in. (mm)	(E <sub>T</sub> ) Max. in.-lbs./cycle (Nm/cycle)	(E <sub>T</sub> C) Max. in.-lbs./hour (Nm/hr)	(F <sub>P</sub> ) Max. End Shock Force lbs. (N)	Nominal Return Force BA* lbs. (N)	A in. (mm)	F in. (mm)	Y in. (mm)	Z in. (mm)	With BA		Model Weight lbs. (Kg)
										CP* in. (mm)	FP* in. (mm)	
HDA 4.0 x 2	2 (50)	120,000 (13 600)	7,200,000 (813 500)	80,000 (355 900)	250 (1 125)	16.9 (430)	12.0 (304)	13.9 (354)	4.0 (101)	7.1 (180)	4.3 (108)	141 (64)
HDA 4.0 x 4	4 (100)	240,000 (27 100)	13,973,200 (1 578 800)	80,000 (355 900)	250 (1 125)	20.9 (532)	14.0 (355)	15.9 (405)	6.0 (152)	7.1 (180)	4.3 (108)	154 (70)
HDA 4.0 x 6	6 (150)	360,000 (40 700)	15,941,300 (1 801 100)	80,000 (355 900)	250 (1 125)	24.9 (632)	15.9 (405)	17.9 (455)	8.0 (202)	7.1 (180)	4.3 (108)	168 (76)
HDA 4.0 x 8	8 (200)	480,000 (54 200)	17,988,100 (2 032 400)	80,000 (355 900)	250 (1 125)	28.9 (735)	18.0 (457)	20.0 (507)	10.0 (253)	7.1 (180)	4.3 (108)	181 (82)
HDA 4.0 x 10	10 (250)	600,000 (67 800)	19,956,100 (2 254 700)	80,000 (355 900)	250 (1 125)	32.9 (836)	20.0 (507)	21.9 (557)	12.0 (304)	7.1 (180)	4.3 (108)	192 (87)

- Notes: 1. HDA shock absorbers will function satisfactorily at 5% of their maximum rated energy per cycle. If less than these values, a smaller model should be specified.  
 2. It is recommended that the customer consult ITT Enidine for safety-related overhead crane applications.  
 3. The energy data listed is for ideal linear impacts only. If side load conditions exist in the application, contact ITT Enidine for sizing assistance.  
 4. Rear flange mounting of 12 inch (300 mm) strokes and longer not recommended. Front and rear flange or foot mount configurations are recommended.  
 5. Maximum cycle rate is 60 cycles/hr.  
 6. HDA models which have an impact velocity below 30 in./sec. (.8 m/sec.), please contact ITT Enidine for assistance.  
 7. Maximum allowable applied propelling force: 40,000 (177 900 N)

**HD Series**

Custom-orificed design accommodates specified damping requirements. Computer generated output performance simulation is used to optimize the orifice configuration. Available in standard bore dimensions of up to 5 in. (125mm) and 6 in. (156mm) with strokes over 60 in. (1525mm).

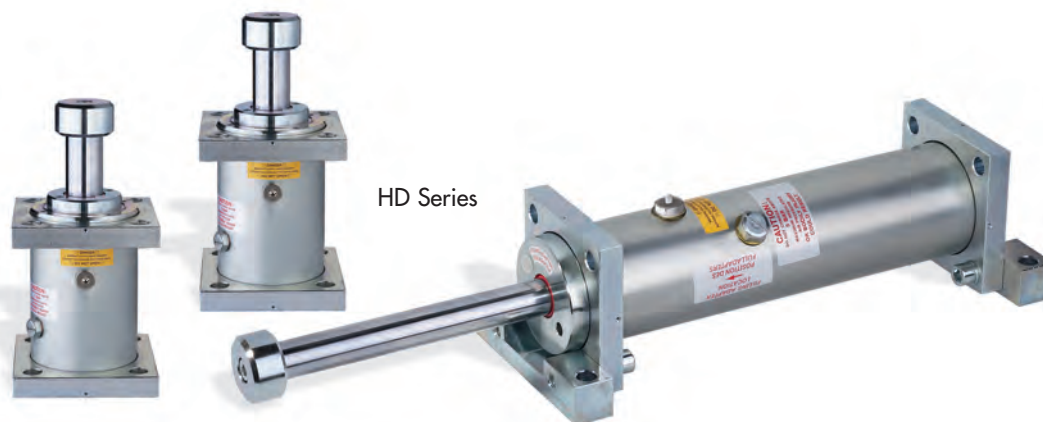
**Features and Benefits HD**

- Compact design smoothly and safely decelerates large energy capacity loads up to 8,000,000 in.-lbs. per cycle (900 000 Nm)
- Engineered to meet OSHA, AISE, CMAA and other safety specifications such as DIN and FEM.
- Internal air charged bladder accumulator replaces mechanical return springs, providing shorter overall length and reduced weight.
- Wide variety of optional configurations including bellows, clevis mounts and safety cables.
- Available in standard adjustable or custom-orificed non-adjustable models.
- Zinc plated external components provide enhanced corrosion protection.
- Epoxy painting and special rod materials are available for use in highly corrosive environments.
- All sizes are fully field repairable.
- Piston rod extension sensor systems available for reuse safety requirements.
- Incorporating optional fluids and seal packages can expand standard operating temperature range from 15°F to 140°F to -30°F to 210°F (-10°C to 60°C) to (-35°C to 100°C)

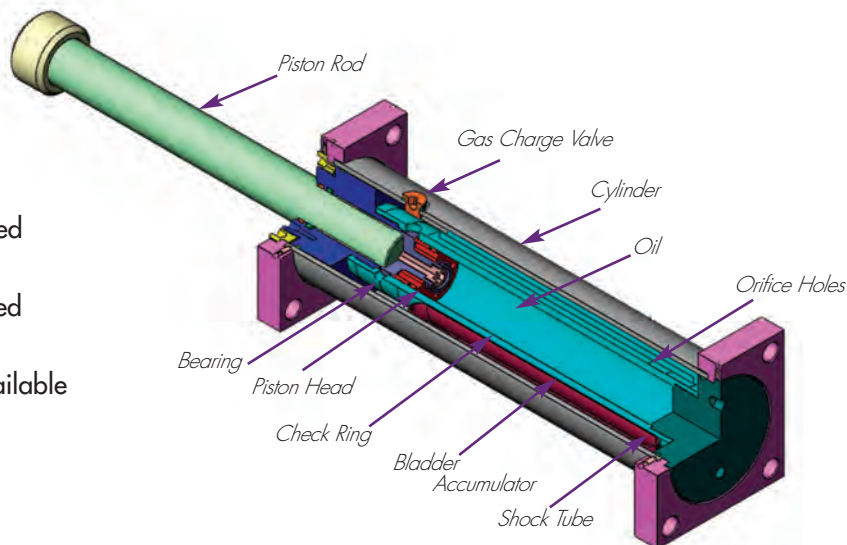

# Heavy Duty Series Shock Absorber

## HD 5.0 Series

### Technical Data

HD 5.0 x 4 → HD 5.0 x 48 Series

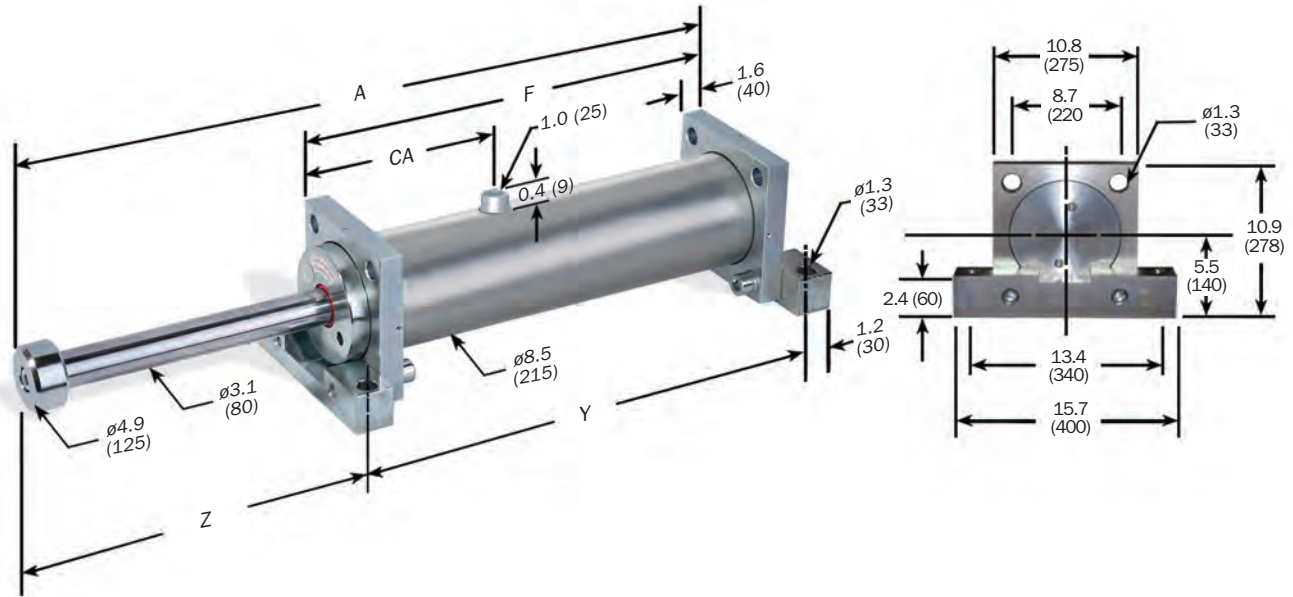

Dimensions are in inches (millimeters).

Note: For TF, FF and FR mounting, delete front foot and dimensions.

Catalog No./ Model	(S) Stroke in. (mm)	(E <sub>T</sub> ) Max. in.-lbs./cycle (Nm/cycle)	(E <sub>T-C</sub> ) Max. in.-lbs./hour (Nm/hr)	(F <sub>P</sub> ) Max. Shock Force lbs. (N)	Nominal Return Force BA* lbs. (N)	A in. (mm)	F in. (mm)	Y in. (mm)	Z in. (mm)	CA in. (mm)	Model Weight lbs. (Kg)
HD 5.0 x 4	4 (100)	414,000 (46 700)	16,000,000 (1 762 621)	124,000 (550 000)	400 (1 760)	23.3 (591)	14.8 (37.5)	17.1 (435)	7.4 (186)	9.1 (230)	192 (87)
HD 5.0 x 6	6 (150)	620,000 (70 000)	17,720,000 (2 002 337)	124,000 (550 000)	400 (1 760)	27.3 (693)	16.8 (426)	19.1 (486)	9.4 (237)	9.1 (230)	207 (94)
HD 5.0 x 8	8 (200)	828,000 (93 500)	19,841,000 (2 242 053)	124,000 (550 000)	400 (1 760)	31.3 (795)	18.8 (477)	21.1 (537)	11.4 (288)	9.1 (230)	223 (101)
HD 5.0 x 10	10 (250)	1,036,000 (117 000)	21,921,000 (2 477 070)	124,000 (550 000)	400 (1 760)	35.3 (895)	20.8 (527)	23.1 (587)	13.4 (338)	9.1 (230)	238 (108)
HD 5.0 x 12	12 (300)	1,239,000 (140 000)	24,042,000 (2 716 786)	124,000 (550 000)	400 (1 760)	39.3 (997)	22.8 (578)	25.1 (638)	15.4 (389)	9.1 (230)	251 (114)
HD 5.0 x 16	16 (400)	1,655,000 (187 000)	28,285,000 (3 196 219)	124,000 (550 000)	400 (1 760)	47.3 (1 201)	26.8 (680)	29.1 (740)	19.4 (491)	9.1 (230)	282 (128)
HD 5.0 x 20	20 (500)	2,071,000 (234 000)	36,688,000 (4 145 684)	124,000 (550 000)	400 (1 760)	59.2 (1 504)	34.7 (882)	37.1 (942)	23.3 (592)	13.0 (230)	348 (158)
HD 5.0 x 24	24 (600)	2,478,000 (280 000)	40,930,000 (4 625 117)	124,000 (550 000)	400 (1 760)	67.2 (1 708)	38.7 (984)	41.1 (1 044)	27.3 (694)	13.0 (230)	377 (171)
HD 5.0 x 28	28 (700)	2,894,000 (327 000)	45,132,000 (5 099 849)	124,000 (550 000)	400 (1 760)	75.2 (1 910)	42.7 (1 085)	45.1 (1 145)	31.3 (795)	13.0 (230)	407 (185)
HD 5.0 x 32	32 (800)	3,310,000 (374 000)	49,374,000 (5 579 282)	124,000 (550 000)	400 (1 760)	83.2 (2 114)	46.7 (1 187)	49.1 (1 247)	35.3 (897)	13.0 (230)	437 (198)
HD 5.0 x 40	40 (1 000)	4,133,000 (467 000)	57,818,000 (6 533 447)	124,000 (550 000)	400 (1 760)	99.2 (2 520)	54.7 (1 390)	57.1 (1 450)	43.3 (1 100)	13.0 (231)	496 (225)
HD 5.0 x 48	48 (1 200)	4,750,000 (535 800)	66,262,000 (7 487 613)	92,000 (410 000)	400 (1 760)	115.0 (2 920)	62.6 (1 590)	65.0 (1 650)	51.6 (1 300)	13.0 (230)	534 (242)

- Notes:
1. HD shock absorbers will function satisfactorily at 5% of their maximum rated energy per cycle. HDA models will function satisfactorily at 10% of their maximum rated energy per cycle. If less than these values, a smaller model should be specified.
  2. It is recommended that the customer consult ITT Enidine for safety-related overhead crane applications.
  3. The energy data listed is for ideal linear impacts only. If side load conditions exist in the application, contact ITT Enidine for sizing assistance.
  4. Rear flange mounting of 12 inch (300 mm) strokes and longer not recommended. Front and rear flange or foot mount configurations are recommended.
  5. Maximum cycle rate is 60 cycles/hr.
  6. For impact velocities over 180 in./sec. (4.5 m/s), consult factory.

# Heavy Duty Series Shock Absorber

## HD 6.0 Series

### Technical Data

HD 6.0 x 4 → HD 6.0 x 48 Series

Heavy Duty Series

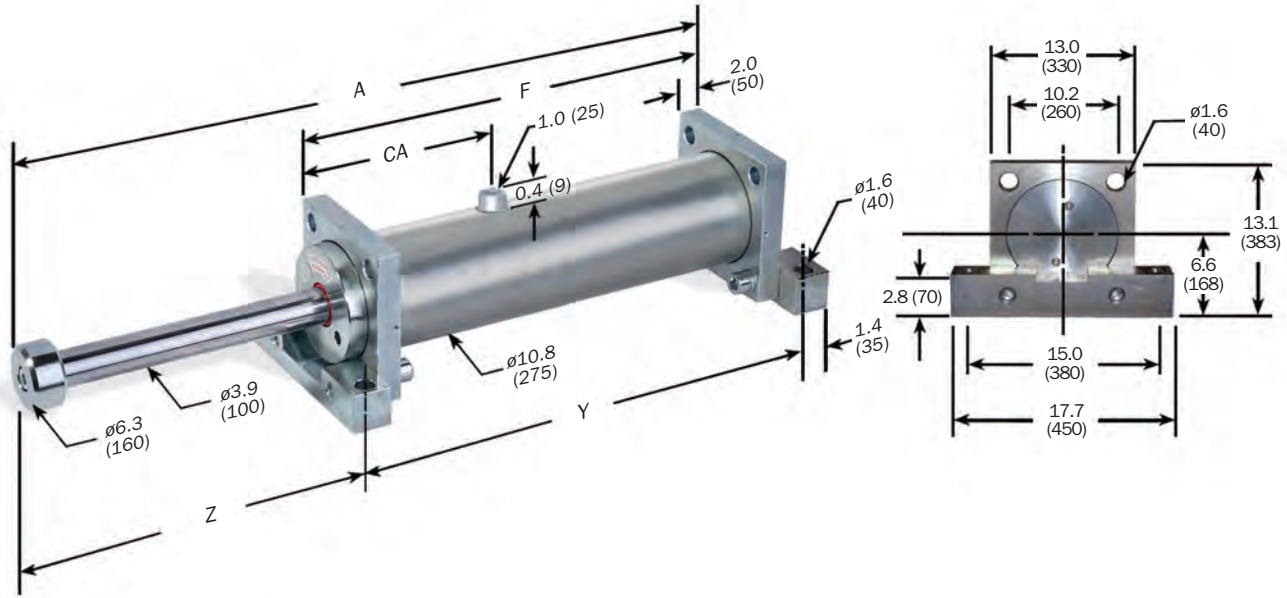

Dimensions are in inches (millimeters).

Note: For TF, FF and FR mounting, delete front foot and dimensions.

Catalog No./ Model	(S) Stroke in. (mm)	(E <sub>T</sub> ) Max. in.-lbs./cycle (Nm/cycle)	(E <sub>T</sub> C) Max. in.-lbs./hour (Nm/hr)	(F <sub>P</sub> ) Max. Shock Force lbs. (N)	Nominal Return Force BA* lbs. (N)	A in. (mm)	F in. (mm)	Y in. (mm)	Z in. (mm)	CA in. (mm)	Model Weight lbs. (Kg)
HD(A) 6.0 x 4	4 (100)	677,000 (76 500)	21,280,000 (2 404 568)	202,250 (900 000)	625 (2 750)	25.1 (637)	15.4 (391)	18.2 (461)	8.3 (211)	7.8 (197)	362 (164)
HD(A) 6.0 x 6	6 (150)	1,010,000 (114 000)	23,933,000 (2 704 389)	202,250 (900 000)	625 (2 750)	29.1 (737)	17.4 (441)	20.2 (511)	10.3 (261)	7.8 (197)	386 (175)
HD(A) 6.0 x 8	8 (200)	1,354,000 (153 000)	26,586,000 (3 004 211)	202,250 (900 000)	625 (2 750)	33.1 (839)	19.4 (492)	22.2 (562)	12.3 (312)	7.8 (197)	410 (186)
HD(A) 6.0 x 10	10 (250)	1,690,000 (191 000)	29,345,000 (3 316 025)	202,250 (900 000)	625 (2 750)	37.1 (941)	21.4 (543)	24.2 (613)	14.3 (363)	7.8 (197)	432 (196)
HD(A) 6.0 x 12	12 (300)	1,982,000 (224 000)	32,052,000 (3 621 843)	202,250 (900 000)	625 (2 750)	41.1 (1 043)	23.4 (594)	26.2 (664)	16.3 (414)	7.8 (197)	456 (207)
HD 6.0 x 16	16 (400)	2,708,000 (306 000)	37,465,000 (4 233 478)	202,250 (900 000)	625 (2 750)	49.1 (1 246)	27.4 (696)	30.2 (766)	20.3 (515)	7.8 (197)	503 (228)
HD 6.0 x 20	20 (500)	3,380,000 (382 000)	42,877,000 (4 845 114)	202,250 (900 000)	625 (2 750)	57.1 (1 450)	31.4 (798)	34.2 (868)	24.3 (617)	7.8 (197)	551 (250)
HD 6.0 x 24	24 (600)	4,062,000 (459 000)	53,862,000 (6 086 375)	202,250 (900 000)	625 (2 750)	69.7 (1 769)	40.0 (1 015)	42.7 (1 085)	28.4 (719)	12.3 (312)	681 (309)
HD 6.0 x 30	30 (750)	5,070,000 (573 000)	61,928,000 (6 997 832)	202,250 (900 000)	625 (2 750)	81.6 (2 073)	46.0 (1 167)	48.7 (1 237)	34.3 (871)	12.3 (312)	752 (341)
HD 6.0 x 36	36 (900)	6,093,000 (688 500)	70,047,000 (7 915 285)	202,250 (900 000)	625 (2 750)	93.7 (2 379)	52.0 (1 320)	54.7 (1 390)	40.4 (1 024)	12.3 (312)	822 (373)
HD 6.0 X 42	42 (1 050)	7,106,000 (803 000)	78,113,000 (8 826 743)	202,250 (900 000)	625 (2 750)	105.6 (2 683)	58.0 (1 472)	60.7 (1 542)	46.3 (1 176)	12.3 (312)	893 (405)
HD 6.0 x 48	48 (1 200)	8,000,000 (898 200)	86,232,000 (9 744 196)	178,000 (790 000)	625 (2 750)	117.7 (2 989)	64.0 (1 625)	66.7 (1 695)	52.4 (1 329)	12.3 (312)	966 (438)

Notes: 1. HD shock absorbers will function satisfactorily at 5% of their maximum rated energy per cycle.

HDA models will function satisfactorily at 10% of their maximum rated energy per cycle. If less than these values, a smaller model should be specified.

2. It is recommended that the customer consult ITT Enidine for safety-related overhead crane applications.

3. The energy data listed is for ideal linear impacts only. If side load conditions exist in the application, contact ITT Enidine for sizing assistance.

4. Rear flange mounting of 12 inch (300 mm) strokes and longer not recommended. Front and rear flange or foot mount configurations are recommended.

5. HDA models which have an impact velocity below 30 in./sec (.8 m/sec), please contact ITT Enidine for sizing assistance.

6. Maximum cycle rate is 60 cycles/hr.

7. For impact velocities over 180 in./sec. (4.5 m/s), consult factory.

# Heavy Duty Series Shock Absorber

## Mounting and Accessories for HDN, HD, HDA Series

### Mounting and Accessories

Typical mounting methods are shown below. Special mounting requirements can be accommodated upon request.



TM: Rear Flange Front Foot Mount



FM: Front and Rear Foot Mount  
Also shown is optional safety cable, typically used in overhead applications.



TF: Front and Rear Flanges



FF: Front Flange



CM: Clevis Mount

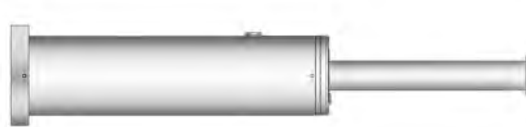

FR: Rear Flange

Note: Rear flange mounting not recommended for stroke lengths above 12 inches. (300 mm)

HD(A) 3.0 x 2 → HD(A) 4.0 x 10 Series

### Clevis Mounts (CM)

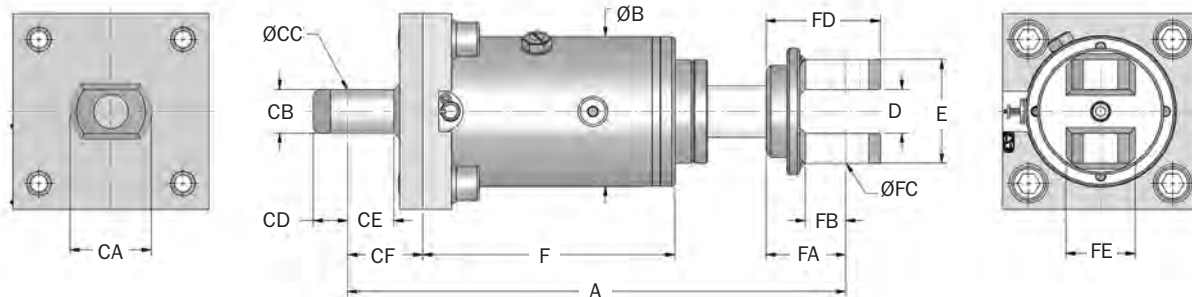

Dimensions are in inches (millimeters).

Note: Piston clevis dimensions are typical both ends on HD(A) 4.0 models.

Catalog No./ Model	HD/HDN						Cylinder Clevis Dimensions						Piston Clevis Dimensions				
	A in. (mm)	B in. (mm)	D in. (mm)	E in. (mm)	F in. (mm)	F in. (mm)	CA in. (mm)	CB in. (mm)	CC in. (mm)	CD in. (mm)	CE in. (mm)	CF in. (mm)	FA in. (mm)	FB in. (mm)	FC in. (mm)	FD in. (mm)	FE in. (mm)
HD(A) 3.0 x 2	17.0 (432)	5.1 (130)	1.5 (38)	3.5 (90)	8.0 (202)	9.3 (235)	2.4 (60)	1.5 (38)	1.0 (25)	1.2 (30)	1.5 (37)	2.6 (65)	2.7 (69)	1.3 (32)	1.0 (25)	3.9 (99)	2.0 (50)
HD(A) 3.0 x 3	19.0 (483)	5.1 (130)	1.5 (38)	3.5 (90)	9.0 (229)	10.3 (261)	2.4 (60)	1.5 (38)	1.0 (25)	1.2 (30)	1.5 (37)	2.6 (65)	2.7 (69)	1.3 (32)	1.0 (25)	3.9 (99)	2.0 (50)
HD(A) 3.0 x 5	23.0 (585)	5.1 (130)	1.5 (38)	3.5 (90)	11.0 (280)	12.3 (312)	2.4 (60)	1.5 (38)	1.0 (25)	1.2 (30)	1.5 (37)	2.6 (65)	2.7 (69)	1.3 (32)	1.0 (25)	3.9 (99)	2.0 (50)
HD(A) 3.0 x 8	29.0 (736)	5.1 (130)	1.5 (38)	3.5 (90)	14.0 (355)	15.2 (387)	2.4 (60)	1.5 (38)	1.0 (25)	1.2 (30)	1.5 (37)	2.6 (65)	2.7 (69)	1.3 (32)	1.0 (25)	3.9 (99)	2.0 (50)
HD(A) 3.0 x 10	33.0 (838)	5.1 (130)	1.5 (38)	3.5 (90)	16.0 (406)	17.2 (438)	2.4 (60)	1.5 (38)	1.0 (25)	1.2 (30)	1.5 (37)	2.6 (65)	2.7 (69)	1.3 (32)	1.0 (25)	3.9 (99)	2.0 (50)
HD(A) 3.0 x 12	37.0 (940)	5.1 (130)	1.5 (38)	3.5 (90)	18.0 (457)	19.3 (489)	2.4 (60)	1.5 (38)	1.0 (25)	1.2 (30)	1.5 (37)	2.6 (65)	2.7 (69)	1.3 (32)	1.0 (25)	3.9 (99)	2.0 (50)
HD(A) 4.0 x 2	22.4 (570)	7.9 (200)	2.6 (65)	5.5 (140)	11.6 (294)	12.0 (304)	-	-	-	-	-	3.5 (90)	3.9 (100)	2.4 (60)	2.0 (50)	5.9 (150)	3.9 (100)
HD(A) 4.0 x 4	26.4 (672)	7.9 (200)	2.6 (65)	5.5 (140)	13.6 (345)	14.0 (355)	-	-	-	-	-	3.5 (90)	3.9 (100)	2.4 (60)	2.0 (50)	5.9 (150)	3.9 (100)
HD(A) 4.0 x 6	30.4 (772)	7.9 (200)	2.6 (65)	5.5 (140)	15.6 (395)	15.9 (405)	-	-	-	-	-	3.5 (90)	3.9 (100)	2.4 (60)	2.0 (50)	5.9 (150)	3.9 (100)
HD(A) 4.0 x 8	34.4 (875)	7.9 (200)	2.6 (65)	5.5 (140)	17.6 (447)	18.0 (457)	-	-	-	-	-	3.5 (90)	3.9 (100)	2.4 (60)	2.0 (50)	5.9 (150)	3.9 (100)
HD(A) 4.0 x 10	38.4 (976)	7.9 (200)	2.6 (65)	5.5 (140)	19.6 (497)	20.0 (507)	-	-	-	-	-	3.5 (90)	3.9 (100)	2.4 (60)	2.0 (50)	5.9 (150)	3.9 (100)

**Optional Piston Rod Return Sensor**

- Magnetic proximity sensor indicates complete piston rod return with 10-foot (3 m) long cable.
- If complete piston rod does not return the circuit remains open. This can be used to trigger a system shut-off.
- Contact ITT Enidine for other available sensor types.
- Sensor port in line with charge port on models HDN 1.5, 2.0 and 4.0. Location offset 90° for models HDN 3.0 and 3.5.

**Sensor Specifications**

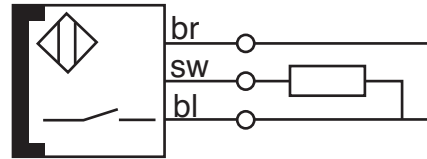

- Voltage 10 - 30V
- Load Current ≤ 200 mA
- Leakage Current ≤ 80 mA
- Load Capacitance ≤ 1.0 mF
- Ambient Temperature: -15° to 160°F (-26° to 71°C)

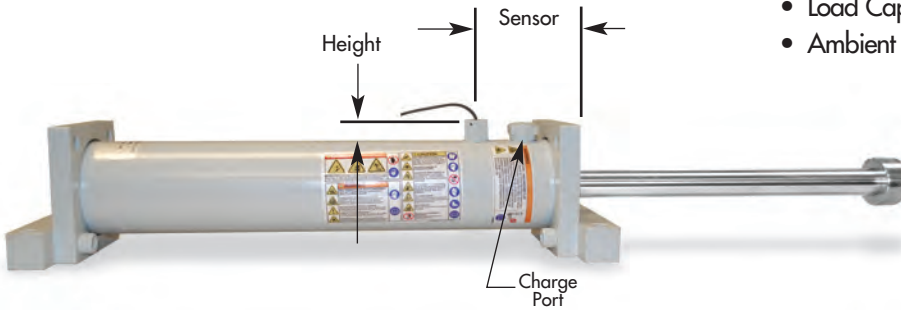

HDN 1.5, 2.0 and 4.0

Model	Sensor in. (mm)	Height in. (mm)
HDN 1.5	3.4 (86)	0.79 (20)
HDN 2.0 x 6-28	3.8 (96)	0.63 (16)
HDN 2.0 x 32-56	6.9 (176)	
HDN 4.0 x 2-10	4.3 (108)	0.35 (9)
HDN 4.0 x 12-48	8.0 (202)	

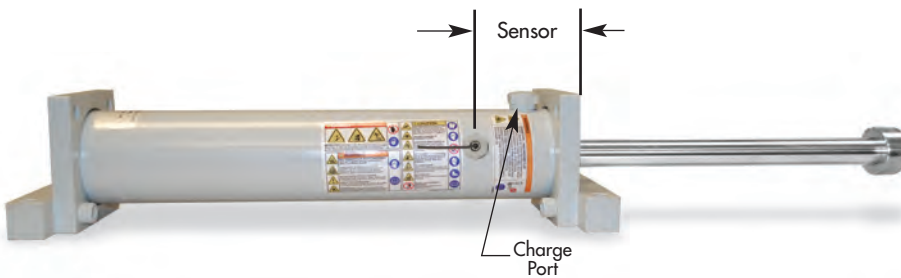

HDN 3.0 and 3.5

Model	Sensor in. (mm)	Height in. (mm)
HDN 3.0 x 2-12	2.4 (61)	0.59 (15)
HDN 3.0 x 14-32	4.4 (111)	
HDN 3.0 x 36-60	6.3 (161)	
HDN 3.5 x 2-16	3.0 (77.4)	0.35 (9)
HDN 3.5 x 20-56	5.2 (132.4)	

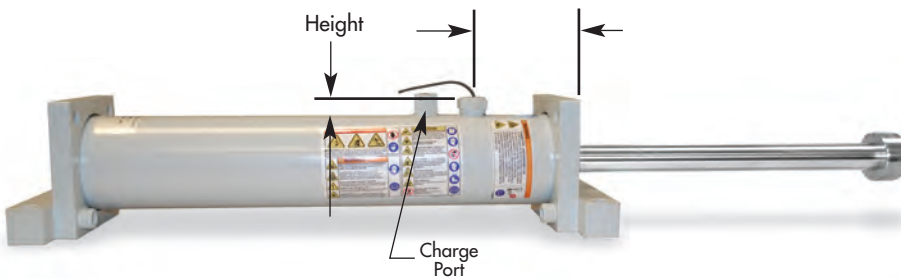

HDN 1.5, 2.0, 3.0, 3.5 and 4.0 BA

Model	Sensor in. (mm)	Height in. (mm)
HDN 1.5	3.4 (86)	0.79 (20)
HDN 2.0 x 6-28	3.8 (96)	0.63 (16)
HDN 2.0 x 32-56	6.9 (176)	
HDN 3.0 x 2-12	2.4 (61)	0.59 (15)
HDN 3.0 x 14-32	4.4 (111)	
HDN 3.0 x 36-60	6.3 (161)	
HDN 3.5 x 2-16	3.0 (77.4)	0.25 (9)
HDN 3.5 x 20-56	5.2 (132.4)	
HDN 4.0 x 2-10	4.3 (108)	0.25 (9)
HDN 4.0 x 12-48	8.0 (202)	

**Urethane Cap**

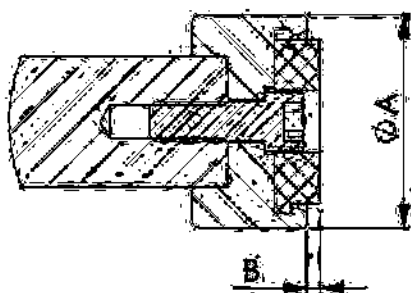

Model	Dia. A (mm)	Dia. A (in.)	B (mm)	B (in.)
HDN 1.5	60	2.36	4	0.16
HDN 2.0	65	2.56	4	0.16
HDN 3.0	70	2.76	4	0.16





HI Series

ITT Enidine's **Heavy Industry (HI) Series** buffers safely protect heavy machinery and equipment during the transfer of materials and movement of products. The large-bore, high-capacity buffers are individually designed to decelerate moving loads under various conditions and in compliance with industry mandated safety standards. Control of bridge cranes, trolley platforms, large container transfer and transportation safety stops are typical installation examples. Industry-proven design technologies, coupled with the experience of a globally installed product base, ensure deliverable performance that exceeds customer expectations.

Prior to HI Series buffer manufacture, computer-simulated response curves are generated to model actual conditions, verify product performance, confirm damping characteristics and generate unique custom-orificed designs that accommodate multi-condition or specific damping requirements.

Characteristics of the HI Series include a nitrogen-charged return system that allows for soft deceleration and positive return in a maintenance-free package. The oversize bore area results in optimal energy absorption capabilities and increased internal safety factors. State-of-the-art testing facilities ensure integrity of design and product performance.

### Features and Benefits

- Compact design smoothly and safely decelerates large energy capacity loads up to 4 million in-lbs. per cycle with standard stroke lengths.
- Engineered to meet OSHA, AISE, CMMA and other safety specifications such as DIN and FEM.
- Nitrogen-charged return system allows for soft deceleration and positive return in a maintenance-free package.
- Wide variety of optional configurations including protective bellows and safety cables.
- Available in custom-orificed non-adjustable models.
- Special epoxy painting and rod materials are available for use in highly corrosive environments.
- Surface treatment (Sea water resistant)  
Housing: gray color, three-part epoxy  
Piston Rod: hard-chrome plated steel
- Incorporating optional fluids and seal packages available to expand standard operating temperature range from (0°F to 175°F) to (-30°F to 250°F) (-10°C to 60°C) to (-35°C to 100°C)



#### ITT Enidine Heavy Industry (HI) Series Buffers

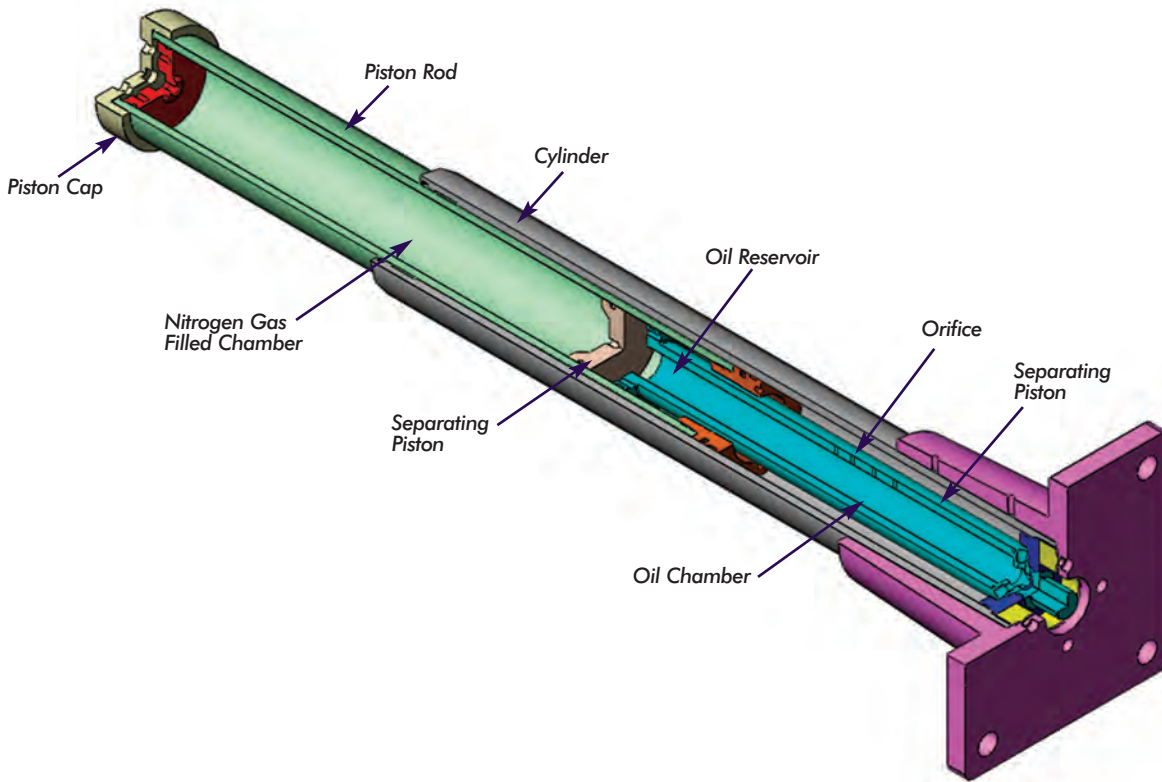

ITT Enidine's Heavy Industry Series (HI) buffers safely protect heavy machinery and equipment during the transfer of materials and movement of products. The large-bore, high-capacity buffers are individually designed to decelerate moving loads under various conditions and in compliance with industry mandated safety standards. Control of bridge cranes, trolley platforms, large container transfer and transportation safety stops are typical installation examples. Industry-proven design technologies, coupled with the experience of a globally installed product base, ensure deliverable performance that exceeds customer expectations.

Prior to HI Series buffer manufacture, computer-simulated response curves are generated to model actual conditions, verify product performance, confirm damping characteristics and generate unique custom-orificed designs that accommodate multi-condition or specific damping requirements.

Characteristics of the HI Series include a nitrogen-charged return system that allows for soft deceleration and positive return in a maintenance-free package. The oversize bore area results in optimal energy absorption capabilities and increased internal safety factors. State-of-the-art testing facilities ensure integrity of design and product performance.

#### Ordering Example

Mounting bracket flange:  
Standard: Rear or Front mount

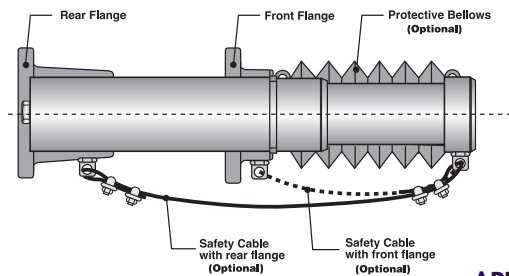

Example:

**4**

Select quantity

**HI 120 x 100**

Select HI Series model from Engineering Data Chart

**FR**

Select mounting method  
• FF (Flange Front)  
• FR (Flange Rear)

**B**

Additional Options  
• B Protective Bellows  
• C Safety cable

#### APPLICATION DATA

Required for all models:

- Vertical/Horizontal Motion
- Weight
- Impact Velocity
- Propelling Force (if any)
- Cycles/Hour
- Temperature/Environment
- Applicable Standards

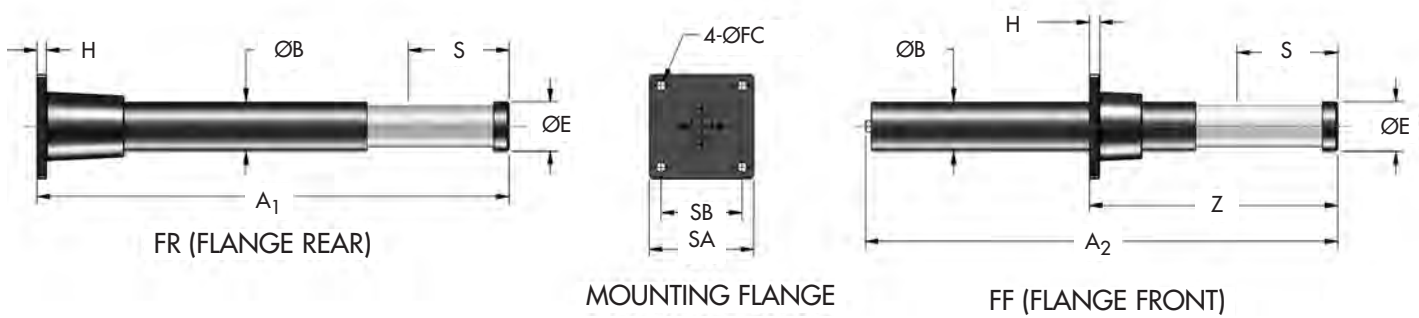

Catalog No./Model	S Stroke in. (mm)	Max. Energy/cycle in.-lbs. (Nm)	Max. Shock Force lbs. (kN)	Return Force		Weight lbs. (Kg)	A <sub>1</sub> in. (mm)	A <sub>2</sub> in. (mm)	Z in. (mm)	H in. (mm)	ØB in. (mm)	SA in. (mm)	SB in. (mm)	ØFC in. (mm)	BOLT SIZE in. (mm)	ØE in. (mm)
				Extension lbs. (kN)	Compression lbs. (kN)											
HI 50 x 50	2 (50)	26,500 (3 000)	15,700 (70)	120 (0,5)	710 (3,2)	11 (5)	10.3 (262)	-	-	0.6 (15)	2.56 (65)	3.94 (100)	2.76 (70)	0.57 (14,5)	1/2 (M14)	2.28 (58)
HI 50 x 100	3.9 (100)	55,500 (6 200)	15,700 (70)	70 (0,3)	140 (0,6)	20 (9)	15.4 (392)	-	-	0.6 (15)	2.56 (65)	3.94 (100)	2.76 (70)	0.57 (14,5)	1/2 (M14)	2.28 (58)
HI 80 x 50	2 (50)	60,200 (6 800)	36,000 (160)	225 (1,0)	430 (1,9)	36 (16)	12.8 (324)	-	-	0.6 (15)	3.35 (85)	5.04 (128)	3.50 (89)	0.79 (20)	3/4 (M18)	3.11 (79)
HI 80 x 100	3.9 (100)	120,500 (13 600)	36,000 (160)	225 (1,0)	1,800 (8,0)	49 (22)	16.7 (424)	-	-	0.6 (15)	3.35 (85)	5.04 (128)	3.50 (89)	0.79 (20)	3/4 (M18)	3.11 (79)
HI 100 x 50	2 (50)	88,500 (10 000)	52,800 (235)	370 (1,65)	4,050 (18,0)	36 (16)	11.9 (302)	11.9 (301)	6.9 (175)	0.8 (20)	3.94 (100)	5.91 (150)	4.72 (120)	0.73 (18,5)	5/8 (M16)	3.90 (99)
HI 100 x 100	3.9 (100)	177,000 (20 000)	52,800 (235)	370 (1,65)	4,050 (18,0)	49 (22)	18.9 (479)	18.6 (473)	9.7 (245)	0.8 (20)	3.94 (100)	5.91 (150)	4.72 (120)	0.73 (18,5)	5/8 (M16)	3.90 (99)
HI 100 x 150	5.9 (150)	265,500 (30 000)	52,800 (235)	370 (1,65)	4,050 (18,0)	62 (28)	24.3 (618)	24.1 (612)	11.8 (300)	0.8 (20)	3.94 (100)	5.91 (150)	4.72 (120)	0.73 (18,5)	5/8 (M16)	3.90 (99)
HI 100 x 200	7.9 (200)	354,000 (40 000)	52,800 (235)	370 (1,65)	4,050 (18,0)	71 (32)	29.8 (756)	29.5 (750)	15.4 (390)	0.8 (20)	3.94 (100)	5.91 (150)	4.72 (120)	0.73 (18,5)	5/8 (M16)	3.90 (99)
HI 100 x 400	15.7 (400)	708,060 (80 000)	52,830 (235)	370 (1,65)	4,050 (18,0)	101 (46)	53.1 (1 349)	53.0 (1 345)	25.4 (645)	0.8 (20)	3.94 (100)	5.91 (150)	4.72 (120)	0.73 (18,5)	5/8 (M16)	3.90 (99)
HI 100 x 500	19.7 (500)	831,900 (94 000)	52,800 (235)	370 (1,65)	4,050 (18,0)	115 (52)	-	63.6 (1 616)	35.0 (890)	0.8 (20)	3.94 (100)	5.91 (150)	4.72 (120)	0.73 (18,5)	5/8 (M16)	3.90 (99)
HI 100 x 600	23.6 (600)	991,200 (112 000)	50,000 (220)	370 (1,65)	4,050 (18,0)	128 (58)	-	74.3 (1 888)	40.9 (1 040)	0.8 (20)	3.94 (100)	5.91 (150)	4.72 (120)	0.73 (18,5)	5/8 (M16)	3.90 (99)
HI 100 x 800	31.5 (800)	1,200,000 (136 000)	45,000 (200)	370 (1,65)	4,050 (18,0)	152 (69)	-	95.5 (2 426)	53.0 (1 345)	0.8 (20)	3.94 (100)	5.91 (150)	4.72 (120)	0.73 (18,5)	5/8 (M16)	3.90 (99)
HI 120 x 100	3.9 (100)	283,200 (32 000)	84,300 (375)	630 (2,8)	11,250 (50,0)	75 (34)	18.5 (471)	18.4 (467)	10.6 (270)	0.8 (20)	4.72 (120)	8.66 (220)	6.69 (170)	1.03 (26,5)	1 (M24)	5.0 (127)
HI 120 x 150	5.9 (150)	424,800 (48 000)	84,300 (375)	630 (2,8)	11,250 (50,0)	86 (39)	23.5 (597)	23.3 (593)	13.0 (330)	0.8 (20)	4.72 (120)	8.66 (220)	6.69 (170)	1.03 (26,5)	1 (M24)	5.0 (127)
HI 120 x 200	7.9 (200)	566,400 (64 000)	84,300 (375)	630 (2,8)	11,250 (50,0)	95 (43)	28.5 (724)	28.3 (720)	15.4 (390)	0.8 (20)	4.72 (120)	8.66 (220)	6.69 (170)	1.03 (26,5)	1 (M24)	5.0 (127)
HI 120 x 300	11.8 (300)	831,900 (94 000)	84,300 (375)	630 (2,8)	11,250 (50,0)	117 (53)	38.3 (973)	38.1 (969)	20.5 (520)	0.8 (20)	4.72 (120)	8.66 (220)	6.69 (170)	1.03 (26,5)	1 (M24)	5.0 (127)
HI 120 x 400	15.7 (400)	1,106,300 (125 000)	84,300 (375)	630 (2,8)	11,250 (50,0)	192 (87)	48.2 (1 225)	48.1 (1 221)	26.8 (680)	1.0 (25)	4.72 (120)	8.66 (220)	6.69 (170)	1.03 (26,5)	1 (M24)	5.0 (127)
HI 120 x 600	23.6 (600)	1,663,900 (188 000)	84,300 (375)	630 (2,8)	11,250 (50,0)	232 (105)	-	67.9 (1 725)	36.0 (915)	1.0 (25)	4.72 (120)	8.66 (220)	6.69 (170)	1.03 (26,5)	1 (M24)	5.0 (127)
HI 120 x 800	31.5 (800)	1,991,250 (225 000)	74,200 (330)	630 (2,8)	11,250 (50,0)	243 (110)	-	91.8 (2 332)	50.8 (1 290)	1.0 (25)	4.72 (120)	8.66 (220)	6.69 (170)	1.03 (26,5)	1 (M24)	5.0 (127)
HI 120 x 1000	39.4 (1000)	2,301,000 (260 000)	67,400 (300)	630 (2,8)	11,250 (50,0)	256 (116)	-	111.7 (2 836)	53.5 (1 360)	1.0 (25)	4.72 (120)	8.66 (220)	6.69 (170)	1.03 (26,5)	1 (M24)	5.0 (127)

# Heavy Industry Shock Absorbers

## HI Series

HI 130 x 250 → HI 150 x 1000 Series

### Technical Data

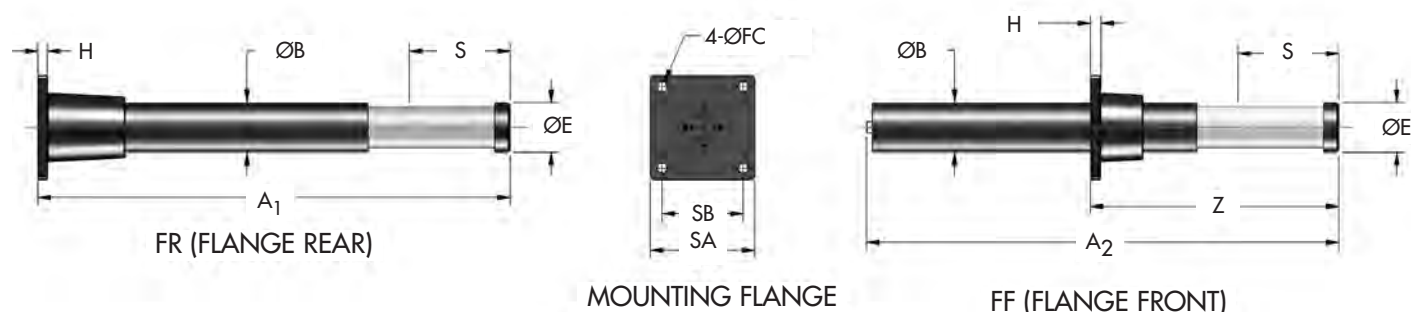

Catalog No./ Model	S Stroke in. (mm)	Max. Energy/cycle in.-lbs. (Nm)	Max. Shock Force lbs. (kN)	Return Force		Weight lbs. (Kg)	A <sub>1</sub> in. (mm)	A <sub>2</sub> in. (mm)	Z in. (mm)	H in. (mm)	ØB in. (mm)	SA in. (mm)	SB in. (mm)	ØFC in. (mm)	BOLT SIZE in. (mm)	ØE in. (mm)
				Extension lbs. (kN)	Compression lbs. (kN)											
HI 130 x 250	9.8 (250)	885,000 (100 000)	106,800 (475)	725 (3,2)	1,300 (50,0)	159 (72)	35.3 (897)	35.2 (894)	21.5 (545)	1.0 (25)	5.12 (130)	10.63 (270)	8.27 (210)	1.03 (26,5)	1 (M24)	5.08 (129)
HI 130 x 300	11.8 (300)	1,062,000 (120 000)	106,800 (475)	720 (3,2)	1,300 (50,0)	175 (79)	40.5 (1 029)	40.4 (1 025)	23.8 (605)	1.0 (25)	5.12 (130)	10.63 (270)	8.27 (210)	1.03 (26,5)	1 (M24)	5.08 (129)
HI 130 x 400	15.7 (400)	1,416,100 (160 000)	106,800 (475)	720 (3,2)	1,300 (50,0)	199 (90)	50.9 (1 293)	50.8 (1 289)	28.9 (735)	1.0 (25)	5.12 (130)	10.63 (270)	8.27 (210)	1.03 (26,5)	1 (M24)	5.08 (129)
HI 130 x 600	23.6 (600)	1,858,500 (210 000)	89,900 (400)	720 (3,2)	10,000 (45,0)	263 (119)	- (1 917)	75.5 (1 917)	41.5 (1 055)	1.0 (25)	5.12 (130)	10.63 (270)	8.27 (210)	1.03 (26,5)	1 (M24)	5.08 (129)
HI 130 x 800	31.5 (800)	2,388,500 (270 000)	89,900 (400)	720 (3,2)	10,000 (45,0)	309 (140)	- (2 445)	96.3 (2 445)	53.0 (1 345)	1.0 (25)	5.12 (130)	10.63 (270)	8.27 (210)	1.03 (26,5)	1 (M24)	5.08 (129)
HI 150 x 115	4.5 (115)	548,700 (62 000)	145,000 (645)	1,125 (5,0)	14,750 (65,7)	124 (56)	20.3 (516)	20.2 (513)	12.6 (320)	1.0 (25)	5.91 (150)	10.63 (270)	8.27 (210)	1.03 (26,5)	1 (M24)	5.87 (149)
HI 150 x 150	5.9 (150)	725,700 (82 000)	145,000 (645)	1,125 (5,0)	14,750 (65,7)	130 (59)	23.9 (606)	23.7 (602)	14.0 (355)	1.0 (25)	5.91 (150)	10.63 (270)	8.27 (210)	1.03 (26,5)	1 (M24)	5.87 (149)
HI 150 x 400	15.7 (400)	1,947,000 (220 000)	145,000 (645)	1,125 (5,0)	14,000 (62,4)	216 (98)	49.5 (1 257)	49.0 (1 245)	28.0 (710)	1.0 (25)	5.91 (150)	10.63 (270)	8.27 (210)	1.03 (26,5)	1 (M24)	5.87 (149)
HI 150 x 500	19.7 (500)	2,433,900 (275 000)	145,000 (645)	1,125 (5,0)	17,000 (75,5)	243 (110)	- (1 498)	59.0 (1 498)	30.3 (770)	1.0 (25)	5.91 (150)	10.63 (270)	8.27 (210)	1.03 (26,5)	1 (M24)	5.87 (149)
HI 150 x 600	23.6 (600)	2,920,500 (330 000)	145,000 (645)	1,125 (5,0)	17,000 (75,5)	265 (120)	- (1 752)	69.0 (1 752)	34.4 (875)	1.0 (25)	5.91 (150)	10.63 (270)	8.27 (210)	1.03 (26,5)	1 (M24)	5.87 (149)
HI 150 x 800	31.5 (800)	3,965,100 (448 000)	144,000 (640)	1,125 (5,0)	15,250 (68,0)	364 (165)	- (2 363)	93.0 (2 363)	48.8 (1 240)	1.0 (25)	5.91 (150)	10.63 (270)	8.27 (210)	1.03 (26,5)	1 (M24)	5.87 (149)
HI 150 x 1000	39.4 (1000)	4,513,500 (510 000)	134,900 (600)	1,125 (5,0)	13,750 (61,0)	397 (180)	- (2 880)	113.4 (2 880)	62.8 (1 595)	1.0 (25)	5.91 (150)	10.63 (270)	8.27 (210)	1.03 (26,5)	1 (M24)	5.87 (149)

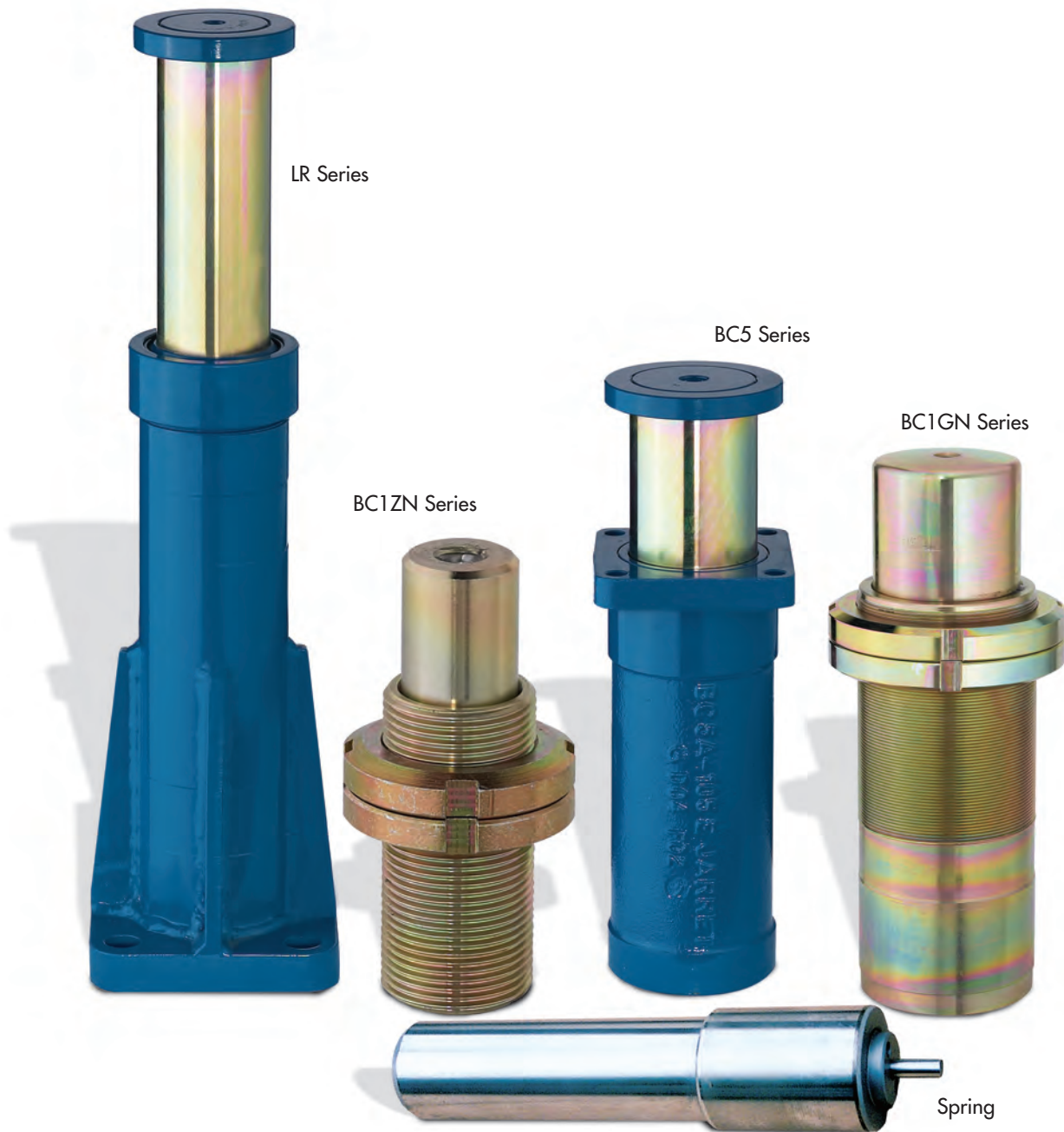

The design of Jarret Series Industrial Shock Absorber utilizes the unique compression and shear characteristics of specially formulated silicone elastomers.

These characteristics allow the energy absorption and return spring functions to be combined into a single unit **without the need for an additional gas or mechanical spring stroke return mechanism.**

#### Applications

Shock protection for all types of industries including:  
**Defense, Automotive, Railroad, Materials Handling,  
 Marine, Pulp/Paper, Metal Production and Processing.**

#### Advantages:

- Simple design
- High reliability
- High damping coefficient
- Low sensitivity to temperature variances

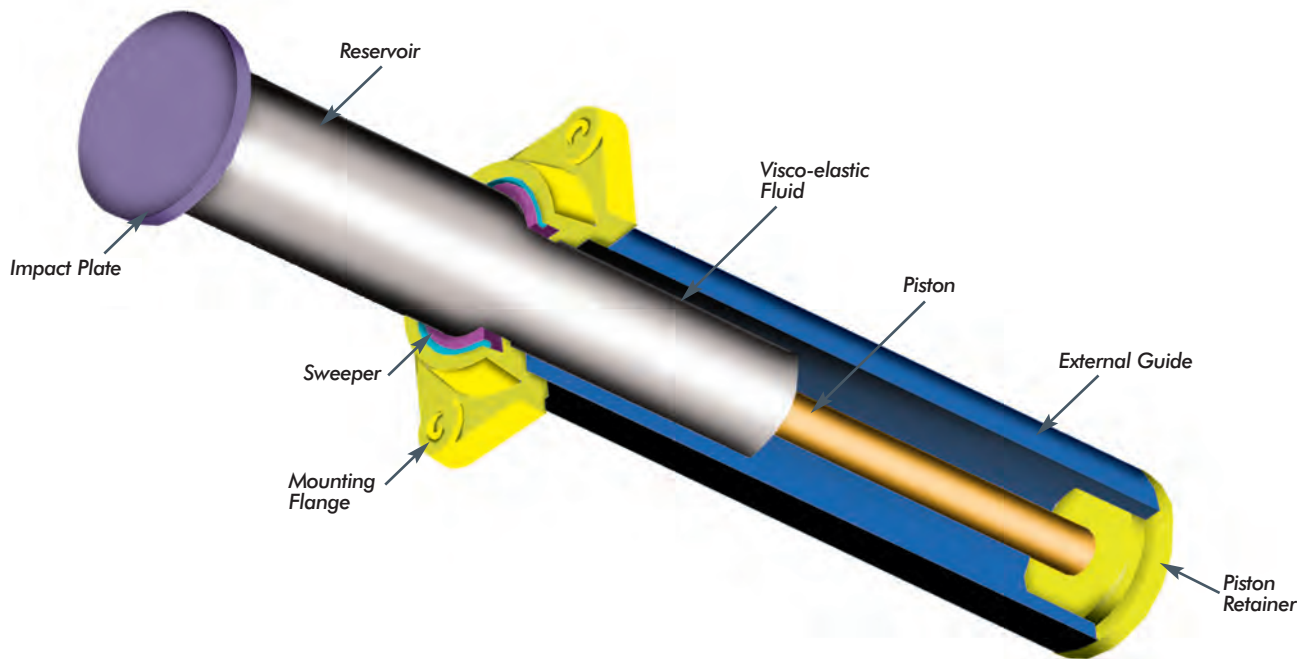

Visco-elastic technology makes use of the fundamental properties of specially formulated Jarret visco-elastic medium.

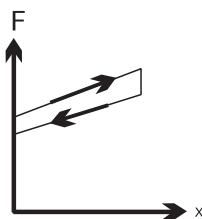
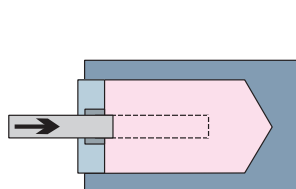

**Compressibility:**

Preloaded spring function  
 $F = F_0 + Kx$

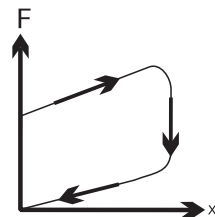
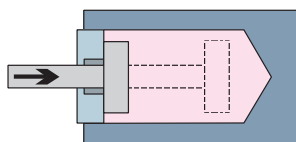

**Viscosity:**

Shock absorber function  
 $F = F_0 + Kx + CV^\alpha$  with  $\alpha$  between 0,1 and 0,4

The two functions can be used separately or in combination, in the same product:

**Preloaded Spring:  
Spring Function Only**

- Hysteresis of between 5% and 10%
- Reduced weight and space requirement
- Force/stroke characteristic is independent of actuation speed

**Shock Absorber Without Spring Return:  
Shock Absorbing Function Only**

- Dampening devices
- Blocking devices

**Preloaded Spring Shock Absorbers:  
Combine Spring and Shock Absorber Functions**

- Dissipate between 30% and 100% of energy
- Force/stroke characteristics remain relatively unchanged between 15°F and 160°F (-10°C and + 70°C)

\* Spring and shock absorber products are capable of functioning between 15°F and 160°F (-10°C and + 70°C). However, standard products are not intended for use over the full rated temperature range. Consult factory for special product considerations required to accommodate operation over a wide temperature range.

BC1ZN → BC1GN Series

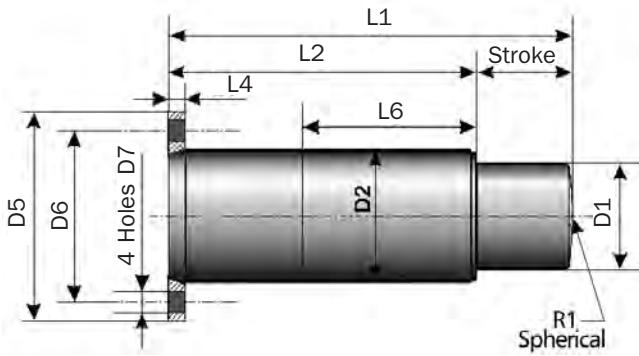

Rear Flange Mounting - Fa

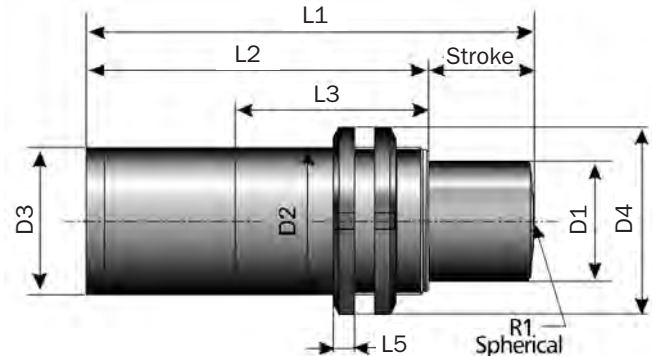

Threaded Body Mounting - Fc

Catalog No./ Model	Max Energy Capacity in-lbs. (kJ)	Stroke in. (mm)	Return Force		Rdy <sub>0</sub> lbs. (kN)	Rdymax Max Shock Force lbs. (kN)
			Extension lbs. (kN)	Compression lbs. (kN)		
BC1ZN	885 (0,1)	0.47 (12)	211 (0,94)	1,213 (5,4)	1,349 (6)	2,473 (11)
BC1BN	3,806 (0,43)	0.87 (22)	562 (2,5)	3,147 (14,0)	3,147 (14)	6,070 (27)
BC1DN	13,276 (1,5)	1.4 (35)	1,169 (5,2)	6474 (28,8)	6,295 (28)	13,489 (60)
BC1EN	30,093 (3,4)	1.8 (45)	1,753 (7,8)	9,666 (43,0)	10,116 (45)	22,481 (100)
BC1FN	61,955 (7)	2.4 (60)	3,057 (13,6)	17,220 (76,6)	20,233 (90)	33,721 (150)
BC1GN	123,910 (14)	3.1 (80)	4,271 (19,0)	29,225 (130,0)	29,225 (130)	51,706 (230)

Catalog No./ Model	L1 in. (mm)	L2 in. (mm)	L3 in. (mm)	L4 in. (mm)	L5 in. (mm)	L6 in. (mm)	R1 in. (mm)	D1 in. (mm)	D2 in. (mm)	D3 in. (mm)	D4 in. (mm)	D5 in. (mm)	D6 in. (mm)	D7 in. (mm)	Weight lbs. (kg.)
BC1ZN	2.95 (75)	2.1 (53)	2.1 (52)	0.39 (10)	0.28 (7)	1.7 (43)	—	0.75 (19)	M25 x 1,5	0.79 (20)	1.5 (38)	2.2 (57)	1.6 (41)	0.28 (7)	0.7 (0,3)
BC1BN	4.7 (120)	3.9 (98)	3.8 (96)	0.47 (12)	0.31 (8)	3.4 (86)	—	1.0 (25)	M35 x 1,5	1.3 (32)	2.0 (52)	3.1 (80)	2.4 (60)	0.35 (9)	1.5 (0,7)
BC1BN-M	4.7 (120)	3.9 (98)	3.8 (96)	0.47 (12)	0.35 (9)	—	—	1.0 (25)	M40 x 1,5	1.3 (32)	2.3 (58)	—	—	—	1.8 (0,8)
BC1DN-70	6.9 (175)	5.5 (140)	5.4 (138)	0.47 (12)	0.43 (11)	5.0 (128)	—	1.5 (38)	M50 x 1,5	1.8 (45)	2.8 (70)	3.5 (90)	2.8 (70)	0.35 (9)	4.2 (1,9)
BC1DN-85	6.9 (175)	5.5 (140)	5.4 (138)	0.47 (12)	0.43 (11)	5.0 (128)	—	1.5 (38)	M50 x 1,5	1.8 (45)	2.8 (70)	4.2 (106)	3.3 (85)	0.43 (11)	4.4 (2)
BC1DN-M	6.9 (175)	5.5 (140)	5.4 (138)	0.47 (12)	0.43 (11)	—	—	1.5 (38)	M60 x 2	1.8 (45)	2.8 (70)	—	—	—	4.4 (2)
BC1EN	8.4 (213)	6.6 (168)	6.2 (158)	0.39 (10)	0.51 (13)	6.2 (158)	5.1 (130)	2.4 (60)	M75 x 2	2.8 (72)	3.9 (98)	4.8 (122)	4.0 (100)	0.43 (11)	11 (5)
BC1FN	10.6 (270)	8.3 (210)	5.1 (130)	0.47 (12)	0.63 (16)	5.1 (130)	5.9 (150)	2.9 (74,5)	M90 x 2	3.5 (90)	4.7 (120)	5.9 (150)	4.7 (120)	0.51 (13)	23.1 (10,5)
BC1GN	13.3 (337)	10.1 (257)	5.7 (145)	0.55 (14)	0.75 (19)	5.7 (145)	13.8 (350)	3.5 (90)	M110 x 2	4.3 (110)	5.7 (145)	6.9 (175)	5.6 (143)	0.70 (18)	37.5 (17)

Notes: Spring and shock absorber products are capable of functioning between 15°F and 160°F (-10°C and +70°C). However, standard products are not intended for use over the full rated temperature range. Consult factory for special product considerations required to accommodate operation over a wide temperature range.

# Jarret Shock Absorbers

## BC1N Series

### Sizing Example

BC1ZN → BC1GN Series

#### 1 - Selection Chart

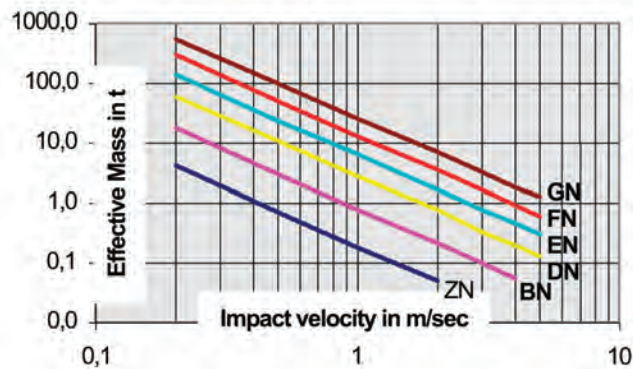

#### Based On

- Impact velocity (V) : 2 m/s
- Operating temperature : 20° to + 40°C
- Surface protection : Electrolytic zinc
- Dynamic performance diagram

Force kN

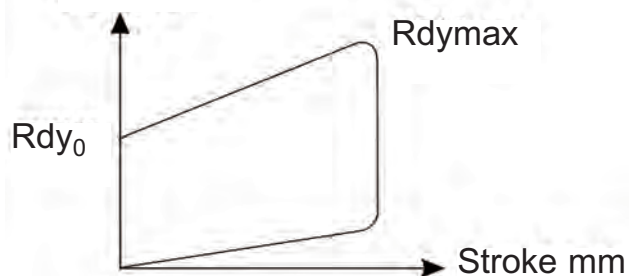

#### Symbols:

- En = Energy Capacity (kJ)
- C = Maximum Stroke (mm)
- Rdy = Dynamic Reaction Force (kN)

#### 2 - Energy Calculation

$$E = \frac{1}{2} M_e V_e^2$$

#### 3 - Allowable Impact Velocity

$$IF < 20 \times \frac{E_n}{E} \text{ Impacts/hour}$$

#### 4 - Effective (Actual) Stroke Calculation

$$C_e = C \left( \sqrt{\frac{E}{E_n (0,03 V + 0,24) + 1,36 - 1,17}} \right)$$

#### 5 - Calculation of Effective Reaction Force Rdy<sub>e</sub>

$$Rdy_e = \left[ \left( \frac{Rdy_{max} - Rdy_0}{C} \right) \times C_e + Rdy_0 \right] (0,1V + 0,8)$$

#### 6 - Application Example

Given data: Effective mass = 15 t  
 Effective velocity = 0,8 m/s  
 Impact frequency: 25 impacts/hour

1. Energy dissipated per impact:  $E = \frac{1}{2} (15)(0,8) = 4,8 \text{ kJ}$

2. BC1FN Selected

3. Allowable impact frequency  $IF < 20 \times 7 / 4.8 = 29$   
 $25 < 29$

4. Effective (Actual) Stroke:

$$C_e = 60 \left( \sqrt{\frac{4,8}{7 (0,03 \times 0,8 + 0,24) + 1,36 - 1,17}} \right)$$

$C_e = 49 \text{ mm}$

5. Effective Reaction Force:

$$Rdy_e = \left[ \frac{(150 - 90) \times 49 + 90}{60} \right] (0,1 \times 0,8 + 0,8)$$

$Rdy_e = 122 \text{ kN}$

6. Compare standards to results:

	BC1FN		APPLICATION
E (kJ) =	7	>	4,8
C (mm) =	60	>	49
Rdymax (kN)	150	>	122

**All performance characteristics can be modified.  
 Please advise us of your specific requirements.**

BC5A → BC5E Series

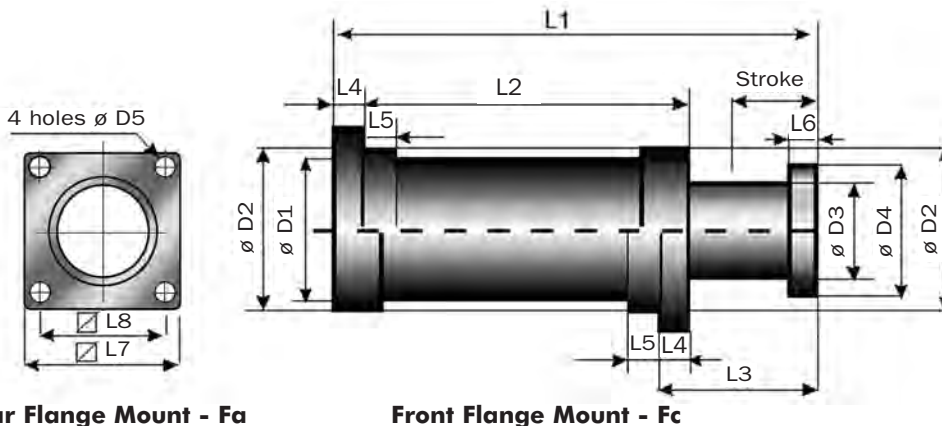

Rear Flange Mount - Fa

Front Flange Mount - Fc

Catalog No./ Model	Max Energy Capacity in-lbs. (kJ)	Stroke in. (mm)	Return Force		Rdy <sub>0</sub> lbs. (kN)	Rdymax Max Shock Force lbs. (kN)
			Extension lbs. (kN)	Compression lbs. (kN)		
BC5A-105	221,268 (25)	4.1 (105)	4,159 (18,5)	31,630 (140,7)	37,543 (167)	69,691 (310)
BC5B-130	442,537 (50)	4.7 (130)	13,039 (58,0)	58,416 (259,9)	69,691 (310)	121,397 (540)
BC5C-140	663,806 (75)	5.5 (140)	11,015 (49,0)	73,827 (328,4)	89,924 (400)	157,366 (700)
BC5D-160	885,075 (100)	6.3 (160)	13,376 (59,5)	85,427 (380,0)	105,660 (470)	184,343 (820)
BC5E-180	1,327,612 (150)	7.1 (180)	26,269 (117,0)	122,656 (546)	143,878 (640)	247,290 (1 100)

Catalog No./ Model	L1 in. (mm)	L2 in. (mm)	L3 in. (mm)	L4 in. (mm)	L5 in. (mm)	L6 in. (mm)	L7 in. (mm)	L8 in. (mm)	D1 in. (mm)	D2 in. (mm)	D3 in. (mm)	D4 in. (mm)	D5 in. (mm)	Weight lbs. (kg)
BC5A-105	16.3 (415)	10.8 (275)	5.5 (140)	0.79 (20)	1.2 (30)	0.59 (15)	5.3 (135)	4.1 (105)	4.6 (116)	4.6 (116)	3.4 (87)	4.7 (120)	0.55 (14)	55 (25)
BC5B-130	19.7 (500)	12.8 (325)	6.9 (175)	1.0 (25)	1.3 (33)	1.2 (30)	6.1 (155)	4.9 (125)	5.6 (142)	5.6 (142)	4.5 (115)	5.4 (138)	0.55 (14)	88 (40)
BC5C-140	20.5 (520)	12.4 (315)	8.1 (205)	1.2 (30)	1.4 (36)	1.4 (35)	6.9 (175)	5.5 (140)	6.3 (160)	6.3 (160)	5.2 (132)	6.2 (158)	0.70 (18)	99 (45)
BC5D-160	23 (585)	13.8 (350)	9.3 (235)	1.4 (35)	1.6 (40)	1.6 (40)	8.5 (215)	6.7 (170)	7.1 (180)	7.1 (180)	6.0 (153)	7.3 (185)	0.87 (22)	161 (73)
BC5E-180	26.4 (670)	15.9 (405)	10.4 (265)	1.6 (40)	1.8 (45)	1.8 (45)	9.8 (250)	7.7 (195)	8.5 (215)	8.5 (215)	7.2 (182)	8.7 (220)	1.0 (26)	258 (117)

Impact Speed: BC5 Series shock absorbers are designed for impact velocities of up to 4 m/sec. Higher impact velocities require custom modification.  
Spring and shock absorber products are capable of functioning between 15°F and 160°F (-10°C and + 70°C). However, standard products are not intended for use over the full rated temperature range. Consult factory for special product considerations required to accommodate operation over a wide temperature range.



# Jarret Shock Absorbers

## BC5 Series

BC5A → BC5E Series

### Sizing Example

#### Based On

- Impact velocity (V) : 2 m/s
- Operating temperature : 20° to + 40°C
- Surface protection : Electrolytic zinc
- Dynamic performance diagram

Force kN

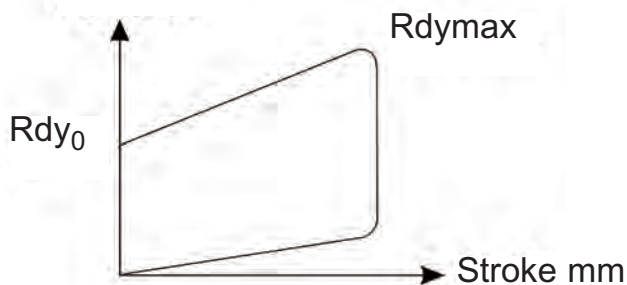

#### Symbols:

- En = Energy Capacity (kJ)
- C = Maximum Stroke (mm)
- Rdy = Dynamic Reaction Force (kN)

#### 1 - Energy Calculation

$$E = \frac{1}{2} M_e V_e^2$$

#### 2 - Allowable Impact Frequency (IF)

$$IF < 15 \times \frac{E_n}{E} \text{ Impacts/hour}$$

#### 3 - Effective Stroke Calculation

$$C_e = C \left( \sqrt{\frac{E}{E_n (0,03 V + 0,24)}} + 1,36 - 1,17 \right)$$

#### 4 - Calculation of Effective Reaction Rdy<sub>e</sub>

$$Rdy_e = \left[ \left( \frac{Rdy_{max} - Rdy_0}{C} \right) \times C_e + Rdy_0 \right] (0,1V + 0,8)$$

#### 5 - Application Example

**Data:** Two shock absorbers in series, Effective mass m=300 t, Impact speed v = 1,2 m/s (which is an impact of 0,6 m/s on each shock absorber), Impact frequency = 15 impacts/hour, Maximum allowable structural load 1000 kN

$$1: E = \frac{1}{2} \left( \frac{1}{2} mV^2 \right)$$

$$E = \frac{1}{2} \left( \frac{1}{2} 300 \times 1,2^2 \right) = 108 \text{ kJ}$$

2. Selection BC5E-180

3. Maximum allowable impact frequency is  $15 \times \frac{150}{108}$  21 impacts/hour. Therefore 15 impacts/hour is acceptable.

$$15 < 15 \times \frac{150}{108}$$

$$15 < 21$$

4. Effective (actual) stroke is 167 mm

$$C_e = 180 \times \left( \sqrt{\frac{108}{150 (0,03 \times 0,6 + 0,24)}} + 1,36 - 1,17 \right) = 156 \text{ mm}$$

$$5. Rdy_e = \left[ (1\ 100 - 640) \times \frac{156}{180} + 640 \right] (0,1 \times 0,6 + 0,8)$$

$$Rdy_e = 893 \text{ kN} < 1000 \text{ kN}$$

6. Compare standards to results:

	BC5E-180	APPLICATION
E (kJ) =	150	> 108
IF =	21	> 15
C (mm) =	180	> 156
Rdy <sub>max</sub> (kN)	1100	> 893

Note: maximum allowed structural load is 1 000 kN > 893 kN

**All performance characteristics can be modified.  
Please advise us of your specific requirements.**

XLR6-150 → XLR-800 Series

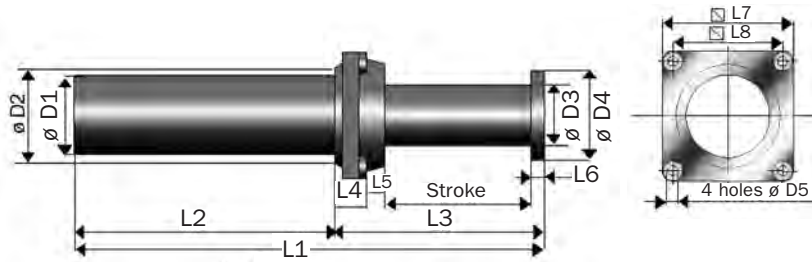

XLR Series - Front Flange Mount- Fc

Catalog No./ Model	Max Energy Capacity in-lbs. (kJ)	Stroke in. (mm)	Return Force		Rdy <sub>0</sub> lbs. (kN)	Rdy <sub>max</sub> Shock Force lbs. (kN)
			Extension lbs. (kN)	Compression lbs. (kN)		
XLR6-150	53,104 (6)	5.9 (150)	652 (2,9)	4,609 (20,5)	5,620 (25)	11,240 (50)
XLR12-150	106,209 (12)	5.9 (150)	1,866 (8,3)	8,655 (38,5)	14,837 (66)	22,481 (100)
XLR12-200	106,209 (12)	7.9 (200)	1,259 (5,6)	6,744 (30,0)	9,442 (42)	17,535 (78)
XLR25-200	221,269 (25)	7.9 (200)	3,012 (13,4)	16,726 (74,4)	21,537 (95)	33,721 (150)
XLR25-270	221,269 (25)	10.6 (270)	2,495 (11,1)	11,555 (51,4)	14,837 (66)	25,179 (112)
XLR50-275	442,537 (50)	10.8 (275)	4,429 (19,7)	29,225 (130,0)	26,527 (118)	51,706 (230)
XLR50-400	442,537 (50)	15.7 (400)	2,900 (12,9)	18,839 (83,8)	16,861 (75)	33,721 (150)
XLR100-400	885,075 (100)	15.7 (400)	5,620 (25,0)	36,531 (162,5)	39,342 (175)	71,939 (320)
XLR100-600	885,075 (100)	23.6 (600)	2,608 (11,6)	29,765 (132,4)	19,109 (85)	51,706 (230)
XLR150-800	1,327,612 (150)	31.5 (800)	5,216 (23,2)	34,216 (152,2)	17,984 (80)	56,202 (250)

Impact Speed: Types XLR and BCLR Series shock absorbers are designed for impact velocities of up to 2 m/sec. Higher impact velocities require custom modification.

Catalog No./ Model	L1 in. (mm)	L2 in. (mm)	L3 in. (mm)	L4 in. (mm)	L5 in. (mm)	L6 in. (mm)	L7 in. (mm)	L8 in. (mm)	D1 in. (mm)	D2 in. (mm)	D3 in. (mm)	D4 in. (mm)	D5 in. (mm)	Weight lbs. (kg.)
XLR6-150	16.1 (410)	9.1 (231)	7.0 (179)	0.75 (19)	0 (0)	0.39 (10)	3.5 (90)	2.8 (70)	2.0 (50)	3.5 (90)	1.5 (38)	2.0 (50)	0.35 (9)	9.3 (4,2)
XLR12-150	18.9 (480)	11.2 (285)	7.7 (195)	0.71 (18)	0.60 (15)	0.47 (12)	4.3 (110)	3.3 (85)	3.0 (75)	3.5 (90)	2.2 (57)	3.1 (80)	0.43 (11)	24.3 (11)
XLR12-200	20.9 (530)	11.2 (285)	9.6 (245)	0.71 (18)	0.60 (15)	0.47 (12)	4.3 (110)	3.3 (85)	3.0 (75)	3.5 (90)	2.2 (57)	3.1 (80)	0.43 (11)	24.3 (11)
XLR25-200	24.4 (620)	14.6 (370)	9.8 (250)	0.79 (20)	0.71 (18)	0.47 (12)	5.3 (135)	4.1 (105)	3.5 (90)	4.3 (110)	2.8 (72)	4.0 (100)	0.6 (14)	44.1 (20)
XLR25-270	27.2 (690)	14.6 (370)	12.6 (320)	0.79 (20)	0.71 (18)	0.47 (12)	5.3 (135)	4.1 (105)	3.5 (90)	4.3 (110)	2.8 (72)	4.0 (100)	0.6 (14)	55.1 (25)
XLR50-275	33.7 (855)	20.5 (520)	13.2 (335)	1.0 (25)	0.79 (20)	0.60 (15)	6.9 (175)	5.5 (140)	4.3 (110)	5.9 (150)	3.4 (87)	4.7 (120)	0.71 (18)	88.2 (40)
XLR50-400	38.6 (980)	20.5 (520)	18.1 (460)	1.0 (25)	0.79 (20)	0.60 (15)	6.9 (175)	5.5 (140)	4.3 (110)	5.9 (150)	3.4 (87)	4.7 (120)	0.71 (18)	88.2 (40)
XLR100-400	53.9 (1370)	35.8 (910)	18.1 (460)	1.0 (25)	0.79 (20)	0.60 (15)	6.9 (175)	5.5 (140)	4.3 (110)	5.9 (150)	3.4 (87)	4.7 (120)	0.71 (18)	143.3 (65)
XLR100-600	61.8 (1570)	35.8 (910)	26.0 (660)	1.0 (25)	0.79 (20)	0.60 (15)	6.9 (175)	5.5 (140)	4.3 (110)	5.9 (150)	3.4 (87)	4.7 (120)	0.71 (18)	143.3 (65)
XLR150-800	103.9 (2640)	70.1 (1780)	33.9 (860)	1.0 (25)	0.79 (20)	0.60 (15)	6.9 (175)	5.5 (140)	4.3 (110)	5.9 (150)	3.4 (87)	4.7 (120)	0.71 (18)	253.5 (115)

Rear Flange Mounting - Fa on Request.

Spring and shock absorber products are capable of functioning between 15°F and 160°F (-10°C and + 70°C). However, standard products are not intended for use over the full rated temperature range. Consult factory for special product considerations required to accommodate operation over a wide temperature range.

# Jarret Shock Absorbers

## XLR Series

### Sizing Example

XLR6-150 → XLR-800 Series

#### Based On

- Impact velocity (V) : 2 m/s
- Operating temperature : 20° to + 40°C
- Surface protection : Electrolytic zinc & Painting
- Dynamic performance diagram

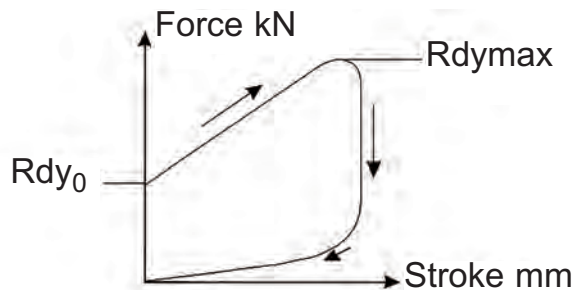

#### Symbols:

- En = Energy Capacity (kJ)
- C = Maximum Stroke (mm)
- Rdy = Dynamic Reaction Force (kN)

#### 1 - Energy Calculation

$$E = \frac{1}{2} M_e V_e^2$$

#### 2 - Allowable Impact Frequency (IF)

$$IF < 8 \times \frac{E_n}{E} \text{ Impacts/hour}$$

#### 3 - Required Stroke Calculation

$$C_e = C \left( \sqrt{\frac{E}{E_n (0,027 V + 0,22)}} + 1,83 - 1,35 \right)$$

#### 4 - Calculation of Effective Reaction Rdy<sub>e</sub>

$$Rdy_e = \left[ \left( \frac{Rdy_{max} - Rdy_0}{C} \right) \times C_e + Rdy_0 \right] (0,1V + 0,8)$$

#### 5 - Application Example Data:

- Effective mass = 30 t
- Effective impact speed = 2,2
- Maximum allowable structural force = 350 kN
- Impact frequency = 10/hr

1: Energy dissipated/impact is 72,6 kJ

$$E = \frac{1}{2} \times 15 \times (2,2)^2$$

$$E = 72,6 \text{ kJ}$$

2: XLR100-400 selected

3: Maximum allowable impact frequency

$$IF < 8 \times 100 / 72,6 = 11$$

(10 < 11 impacts/hour is acceptable)

4: Effective (actual) stroke:

$$C_e = 400 \times \left( \sqrt{\frac{72,6}{100 (0,027 \times 2,7 + 0,22)}} + 1,83 - 1,35 \right)$$

$$C_e = 290,3 \text{ mm}$$

$$5: Rdy_e = \left[ \left( \frac{320 - 175}{400} \right) 290,3 + 175 \right] (0,1 \times 2,2 + 0,8)$$

$$Rdy_e = 285,8 \text{ kN}$$

(which is less than maximum allowable reaction force of 350 kN)

6. Compare standards to results:

	XLR100-400	APPLICATION
E (kJ) =	100	> 72,6
IF =	11	> 10
C (mm) =	400	> 301,8
Rdy <sub>max</sub> (kN)	320	> 290,1

Note: maximum allowed structural load is 350 kN > 290,1 kN

**All performance characteristics can be modified.  
Please advise us of your specific requirements.**

BCLR-100 → BCLR-1000 Series

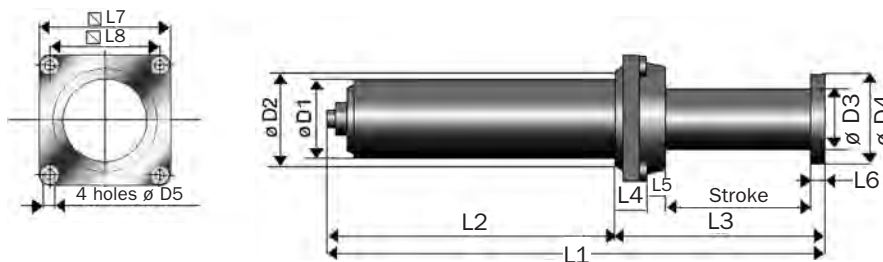

**BCLR Series - Front Flange Mount- Fc**

Catalog No./ Model	Max Energy Capacity in-lbs. (kJ)	Stroke in. (mm)	Return Force		Rdy <sub>0</sub> lbs. (kN)	Rdymax Max Shock Force lbs. (kN)
			Extension lbs. (kN)	Compression lbs. (kN)		
<b>BCLR-100</b>	885,075 (100)	15.7 (400)	6,744 (30,0)	36,403 (161,9)	42,714 (190)	69,691 (310)
<b>BCLR-150</b>	1,327,612 (150)	19.7 (500)	9,330 (41,5)	47,300 (201,4)	44,962 (200)	85,427 (380)
<b>BCLR-220S</b>	1,947,614 (220)	15.7 (400)	10,116 (45,0)	60,698 (270,0)	85,427 (380)	153,994 (685)
<b>BCLR-250</b>	2,212,686 (250)	25.6 (650)	10,116 (45,0)	56,877 (253,0)	60,698 (270)	110,156 (490)
<b>BCLR-400</b>	3,540,298 (400)	33.5 (850)	11,144 (49,6)	69,214 (307,9)	74,187 (330)	134,885 (600)
<b>BCLR-600</b>	5,310,477 (600)	41.3 (1050)	10,678 (47,5)	79,020 (351,5)	83,179 (370)	166,359 (740)
<b>BCLR-800</b>	7,080,597 (800)	47.2 (1200)	14,433 (64,2)	99,141 (441,0)	99,141 (430)	193,336 (860)
<b>BCLR-1000</b>	8,850,746 (1000)	51.2 (1300)	19,109 (85,0)	120,048 (534,0)	112,405 (500)	224,809 (1000)

Impact Speed: Types XLR and BCLR Series shock absorbers are designed for impact velocities of up to 2 m/sec. Higher impact velocities require custom modification.

Catalog No./ Model	L1 in. (mm)	L2 in. (mm)	L3 in. (mm)	L4 in. (mm)	L5 in. (mm)	L6 in. (mm)	L7 in. (mm)	L8 in. (mm)	D1 in. (mm)	D2 in. (mm)	D3 in. (mm)	D4 in. (mm)	D5 in. (mm)	Weight lbs. (kg.)
<b>BCLR-100</b>	44.1 (1120)	26.0 (660)	18.1 (460)	1.0 (25)	0.79 (20)	0.60 (15)	6.9 (175)	5.5 (140)	5.1 (130)	5.9 (150)	4.3 (110)	5.5 (140)	0.71 (18)	139.0 (63)
<b>BCLR-150</b>	53.1 (1350)	30.5 (775)	22.6 (575)	1.2 (30)	1.0 (25)	0.79 (20)	8.5 (215)	6.7 (170)	5.5 (140)	7.3 (185)	4.7 (120)	5.9 (150)	0.87 (22)	198.4 (90)
<b>BCLR-220S</b>	49.5 (1258)	30.8 (783)	18.7 (475)	1.2 (30)	1.0 (25)	0.79 (20)	8.5 (215)	6.7 (170)	6.3 (160)	N/A	5.3 (134)	6.3 (160)	0.87 (22)	243 (110)
<b>BCLR-250</b>	68.9 (1750)	40.4 (1025)	28.5 (725)	1.2 (30)	1.0 (25)	0.79 (20)	8.5 (215)	6.7 (170)	6.1 (155)	7.3 (185)	6.9 (135)	6.7 (170)	0.87 (22)	297.6 (135)
<b>BCLR-400</b>	86.0 (2185)	49.2 (1250)	36.8 (935)	1.4 (35)	1.0 (25)	1.0 (25)	10.4 (265)	8.3 (210)	6.9 (175)	9.3 (235)	5.9 (150)	7.5 (190)	1.1 (27)	480.6 (218)
<b>BCLR-600</b>	100.6 (2555)	55.9 (1420)	44.7 (1135)	1.4 (35)	1.0 (25)	1.0 (25)	10.4 (265)	8.3 (210)	7.9 (200)	9.3 (235)	6.9 (175)	8.5 (215)	1.1 (27)	650.4 (295)
<b>BCLR-800</b>	115.6 (2935)	64.2 (1630)	51.4 (1305)	1.6 (40)	1.4 (35)	1.2 (30)	11.8 (300)	9.4 (240)	8.7 (220)	10.6 (270)	7.5 (190)	9.3 (235)	1.2 (30)	926 (420)
<b>BCLR-1000</b>	127.0 (3225)	71.7 (1820)	55.3 (1405)	1.6 (40)	1.4 (35)	1.2 (30)	11.8 (300)	9.4 (240)	9.1 (230)	10.6 (270)	8.1 (205)	9.8 (248)	1.2 (30)	1036.2 (470)

Rear Flange Mounting - Fa on Request.

Spring and shock absorber products are capable of functioning between 15°F and 160°F (-10°C and + 70°C). However, standard products are not intended for use over the full rated temperature range. Consult factory for special product considerations required to accommodate operation over a wide temperature range.

# Jarret Shock Absorbers

## BCLR Series

### Sizing Example

BCLR-100 → BCLR-1000 Series

#### Based On

- Impact velocity (V) : 2 m/s
- Operating temperature : 20° to + 40°C
- Surface protection : Electrolytic zinc & Painting
- Dynamic performance diagram

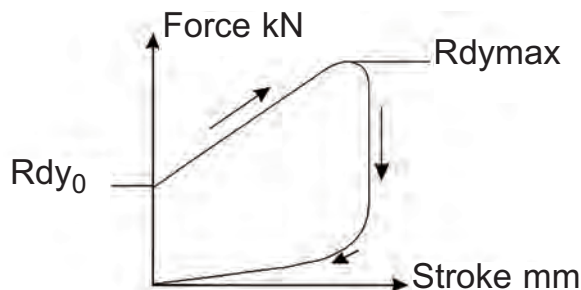

#### Symbols:

En = Energy Capacity (kJ)

C = Maximum Stroke (mm)

Rdy = Dynamic Reaction Force (kN)

#### 1 - Energy Calculation

$$E = \frac{1}{2} M_e V_e^2$$

#### 2 - Allowable Impact Frequency (IF)

$$IF < 8 \times \frac{E_n}{E} \text{ Impacts/hour}$$

#### 3 - Required Stroke Calculation

$$C_e = C \left( \sqrt{\frac{E}{E_n (0,027 V + 0,22)}} + 1,83 - 1,35 \right)$$

#### 4 - Calculation of Effective Reaction Rdy<sub>e</sub>

$$Rdy_e = \left[ \left( \frac{Rdy_{max} - Rdy_0}{C} \right) \times C_e + Rdy_0 \right] (0,1V + 0,8)$$

#### 5 - Application Example:

Effective mass = 75 t

Effective impact speed = 2,7

Maximum allowable structural force: 650 kN

Impact frequency = 10/hr

1: Energy dissipated/impact is 274 kJ

2: BCLR-400 selected

3: Maximum allowable impact frequency  
 $IF < 8 \times 400 / 274 = 12$  (10 impacts/hour is acceptable)  
 $10 < 12$

4: Effective (actual) stroke:

$$C_e = 850 \times \left( \sqrt{\frac{274}{400 (0,027 \times 2,7 + 0,22)}} + 1,83 - 1,35 \right)$$

$$C_e = 587\text{mm}$$

5: Rdy<sub>e</sub> = 520 (0,1 × 2,7 + 0,8) = 556 kN

(which is less than maximum allowable reaction force of 650 kN)

6. Compare standards to results:

	BCLR-400		APPLICATION
E (kJ) =	400	>	274
IF =	12	>	10
C (mm) =	850	>	587
Rdy <sub>max</sub> (kN)	600	>	556

Note: maximum allowed structural load is 650 kN > 556 kN

**All performance characteristics can be modified.  
 Please advise us of your specific requirements.**



*Construction Elevator Emergency Stops*



*Mining Applications*



*Refinery Material Handling Applications*

## Typical Applications

Applications



*High Speed Elevator Applications*



*Material Transport Crane Applications*



*Amusement Ride Emergency Stops*



ITT Enidine Rate Controls are designed to regulate the speed and time required for a mechanism to move from one position to another. Adjustable and non-adjustable models are available to accommodate a wide variety of motion control applications. Both single and double acting hydraulic damper designs allow smooth, controllable machine operation by providing rate control for both linear and rotational (hinged) loads. Each product family offers a variety of stroke lengths from which to choose.

**Adjustable, Double Acting (ADA 500 and ADA 700 Series)** rate controls regulate speed in both tension and/or compression modes independently. ADA products let the user adjust the rate to suit specific application requirements. Fixed orifice interchangeable cartridges are available for the ADA 500 Series, which provide tamperproof operation once the desired rate has been determined. An optional remote adjustment cable provides adjustment control in otherwise inaccessible locations for the ADA 500 Series.

The **DA Series** are non-adjustable, custom-orificed at factory, double acting rate controls which provide smooth, reliable motion control for high load capacities. Tow Bar (TB) snubbers are specially designed DA's which dampen the abrupt starts and stops of power and free conveying systems.

## Features and Benefits

- Extensive product line offers flexibility in both size and load capacities to fulfill a wide range of application requirements.
- Custom stroke lengths and damping characteristics can be designed to suit your application requirements.
- ISO quality standards result in reliable, long-life operation.
- Incorporating optional fluids can expand the standard operational temperature range from (15°F to 180°F) to (-30°F to 210°F).
- A select variety of surface finishes maintains original quality appearance and provides the longest corrosion resistance protection.
- Special materials and finishes available to meet specific customer requirements.



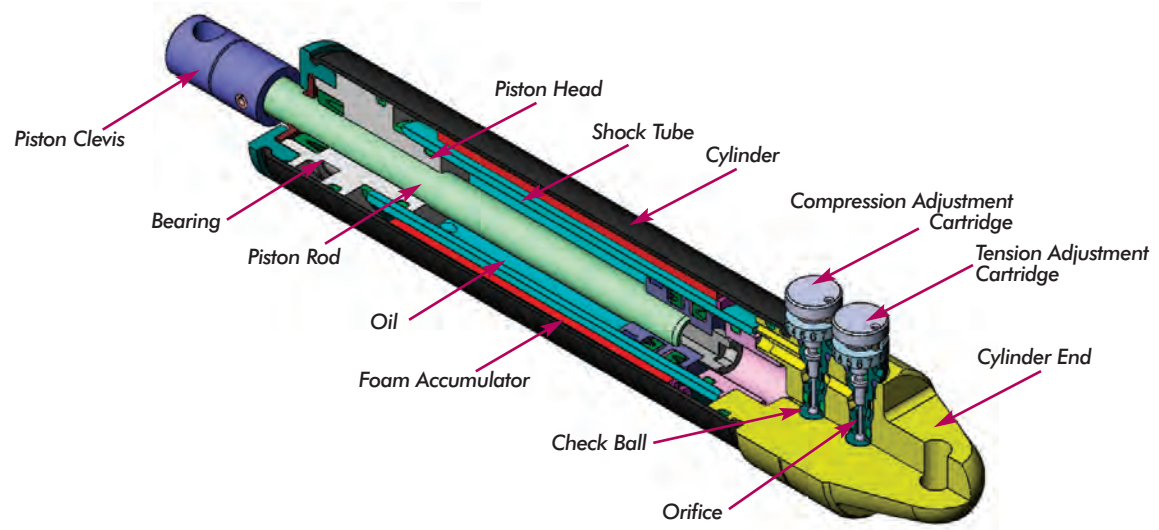

ITT Enidine Double Acting Adjustable (ADA) rate controls control the velocity of both linear and rotational loads throughout their entire motion. Adjustment cartridges on the ADA 500 Series allow flexibility in controlling the speed for an applied force in both the tension and compression directions. Maximum damping is achieved by turning the adjustment knob to the number eight (8) setting, while turning the knob to the zero (0) setting provides minimal resistance. Interchangeable, threaded, fixed-orifice cartridges can provide consistent, tamper-resistant damping to meet particular application requirements.

Resistance is controlled by using a wrench key at either end of the rate control and adjusting the movement by following the stiffer (+) or softer (-) indications. When the rate control is compressed, the oil is orificed through the compression adjustment cartridge and flows freely through the tension adjustment cartridge. The tension cartridge check ball unseats and allows free flow of the oil to the rod end of the shock tube. A foam accumulator is utilized to accept the volume of oil displaced by the piston rod. When the rate control is extended, oil is moved through an internal flow path in the shock tube and is orificed through the tension adjustment cartridge. The compression cartridge check ball unseats and allows free flow of the oil into the blind end of the shock tube.

The ADA 500 Series utilizes two independent adjustment cartridges for motion control in each direction, housed in the cylinder end. The ADA 700 Series has independently controlled tension and compression capabilities located at each end of the unit.

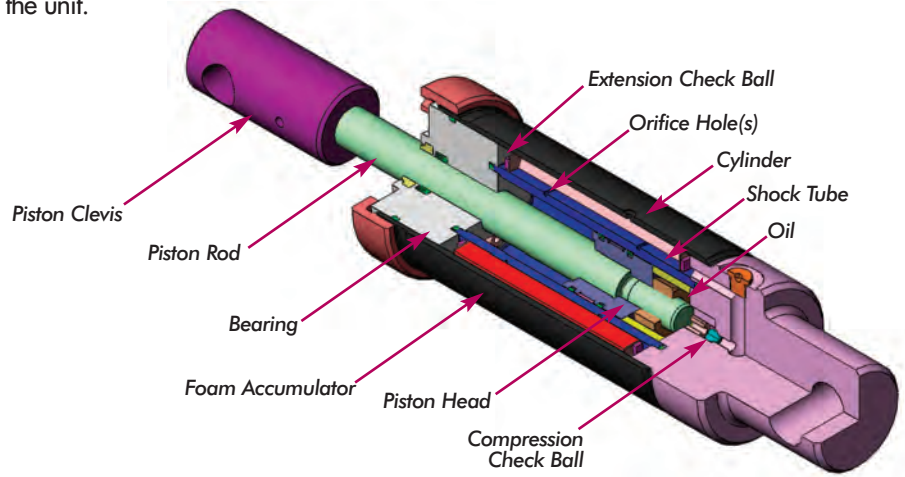

DA Series rate controls are ideally suited for high-energy, heavy load applications requiring rate control in tension, compression or both directions. These non-adjustable, custom-orificed units are designed to specific input conditions, and allow for single and multiple orifice configurations.

passed through the orifice hole(s), a portion of the oil passes through the extension check valve and fills the rod end of the shock tube. The remainder of the oil volume displaced by the piston rod compresses the foam accumulator.

Upon compression of the rate control, the compression check ball seats. As the piston head moves, oil is forced through the orifice hole(s) located in the shock tube, producing the required damping force. After the oil has

Upon extension of the rate control, the extension check ball seats. As the piston head moves, oil is forced through the orifice hole(s) located in the shock tube producing the required damping force. The compression check ball is unseated by the flow of oil which fills the blind end of the shock tube.

ITT Enidine Rate Controls are used to regulate the speed or time required for a mechanism to move from one position to another. They use proven technology to enhance performance in a variety of product applications. Rate controls are typically used to control pneumatic cylinders, linear slides, lids, and other moving mechanisms.

The advantages of using rate controls include:

- 1. Longer Machine Life** – The use of rate controls significantly reduces shock and vibration to machinery caused by uncontrolled machine operation. This further reduces machinery damage, downtime and maintenance costs, while increasing machine life.
- 2. Improved Production Quality** – Harmful effects of uncontrolled motion, such as noise, vibration and damaging impacts, are moderated or eliminated so that production quality is improved.
- 3. Safer Machinery Operation** – Rate controls protect machinery and equipment operators by offering predictable, reliable and controlled machine operation.
- 4. Competitive Advantage** – Machines and end products become more valuable because of increased productivity, longer life, lower maintenance and safer operation.

ITT Enidine offers a wide range of rate controls that provide motion control in tension, compression, or both directions. Adjustable and non-adjustable tamperproof models are available to fit your particular application requirements.

The resisting force provided by ITT Enidine rate controls is typically constant over the entire stroke when the piston rod is moved at a constant velocity, since the rate controls are single orifice products. DA Series models can be custom orificed to provide increasing resisting force over the stroke through the use of multiple orifices in the shock tube. This can be beneficial when controlling the velocity of a lid as it closes, since the torque from the weight of the lid changes as it closes.

### Rate Control Adjustment Techniques

A properly adjusted rate control safely controls machinery operation, and reduces noise levels from uncontrolled motion. To correctly adjust the rate control after it has been properly sized for the application, set the adjustment knob (per the useable adjustment setting graphs for the applicable model). Cycle the mechanism and observe the motion of the system.

If the motion of the mechanism is too fast, move the adjustment dial to the next largest number until the desired velocity is achieved.

If the motion of the mechanism is too slow, move the adjustment dial to the next smallest number until the desired velocity is achieved.

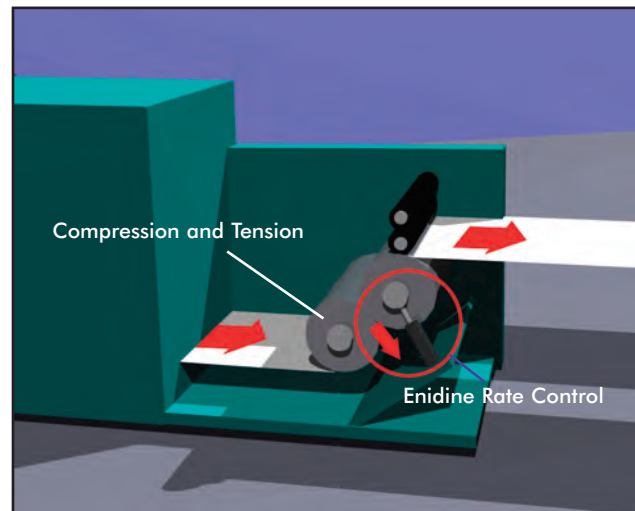
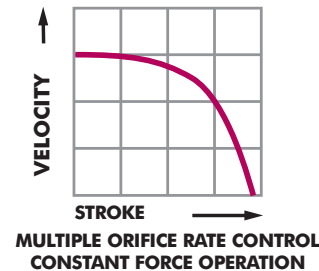
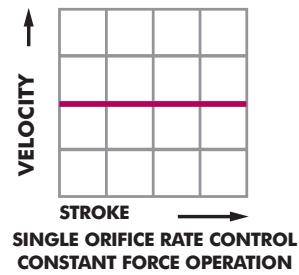

Typical Application: Print Rollers and Paper Tensioners

**Useable Adjustment Setting Range**

Green lines are model's maximum allowable propelling force.

**Damping Force**

ADA 500

**Compression Mode Adjustment Setting Curve**

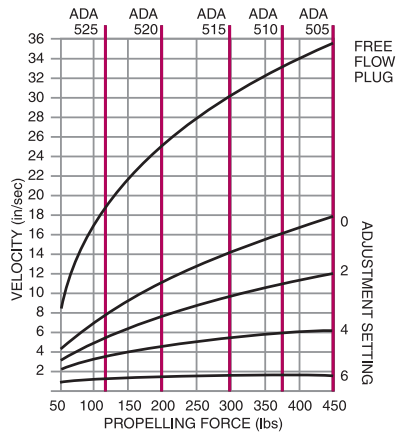

**Tension Mode Adjustment Setting Curve**

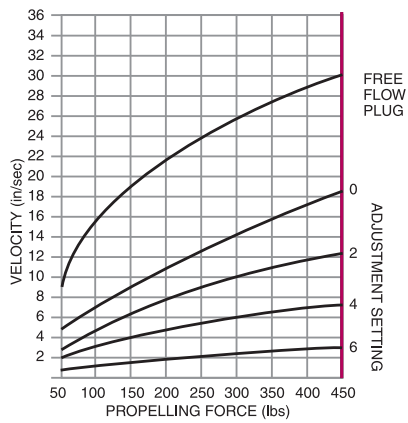

Position 0 provides minimum damping force. Position 8 provides maximum damping force. 180° adjustment with setscrew locking.

- Determine the damping direction (tension [T], compression [C] or both [T and C]), stroke (in. or mm) required, propelling force (lbs. or N), desired velocity (in./sec. or m/s) and cycles per hour.
  - Calculate total energy per hour (in-lbs./hr or Nm/hr).
  - Compare the damping direction (T, C, or T and C), stroke (in. or mm) required, propelling force (lbs. or N) and total energy per hour (in-lbs./hr or Nm/hr) to the values listed in the Rate Controls Engineering Data charts.
- NOTE:** Propelling force and velocity should be measured at the location of the rate control.
- Determine if adjustable or non-adjustable model is desired.
  - Select the appropriate rate control model.
    - For adjustable rate control models, refer to the Useable Adjustment Settings section for the selected model to determine the proper adjustment setting.
    - For non-adjustable rate control models, refer to the Damping Constant Selection Instructions for the selected model to determine the proper damping constant.

**Example:**

- Damping Direction (T,C or T and C): T and C  
 Stroke (S): 4 in. (102 mm)  
 Propelling Force (F<sub>D</sub>): 200 lbs. (890 N) (T and C)  
 Velocity (V): 8 in./sec. (0.2 m/s)  
 Cycles/Hour (C): 20
- Total Energy/Hour: 16,000 in-lbs./hr (1 808 Nm/hr) compression  
 16,000 in-lbs./hr (1 808 Nm/hr) tension  

---

 32,000 in-lbs./hr (3 616 Nm/hr) Total
- Compare damping direction (T and C), stroke, propelling force and total energy per hour, to the values listed in the rate controls engineering data charts.
- An adjustable model is desired.
- Selection: ADA 510 (T and C), The proper adjustment is two (2) in tension and compression per the ADA 500 Series Useable Adjustment Setting Range Curves.

After properly sizing the ADA, the adjustment setting can be determined.

- To determine the approximate adjustment setting when the selected model, propelling force, and velocity are known: compare velocity to the propelling force in the compression and/or tension mode adjustment setting curves. The intersection point of the velocity and the propelling force is the approximate adjustment setting to be used. Adjustment higher or lower than this setting will result in slower or faster damper operation, respectively.
- To determine the velocity when the selected model, adjustment setting, and propelling force are known: compare the propelling force to the adjustment setting in the compression and/or tension mode adjustment setting curves. The intersection point of the propelling force and the adjustment setting is the approximate velocity for the selected model. Higher velocities are obtained at lower adjustment settings and lower velocities are obtained at higher adjustment settings.

**EXAMPLE: Double Acting Application**

- Stroke required: 2 in. (51 mm)  
 Control direction: Tension and Compression  
 Propelling force: 350 lbs. (1 557 N) (tension),  
 400 lbs. (1 780 N) (compression)
- Selection: ADA 505
- Velocity: 11 in./sec. (.28 m/s) (tension),  
 6 in./sec. (.15 m/s) (compression)  
 Intersection point: Adjustment setting 2 (tension),  
 4 (compression)
  - Adjustment setting: 2 (tension), 4 (compression)  
 Velocity: 11 in./sec. (.28 m/s) (tension),  
 6 in./sec. (.15 m/s) (compression)

**NOTE:** When a free flow plug is used, the intersection point of the propelling force and free flow plug curve determines the velocity.

**NOTE:** Propelling force and velocity should be measured at the location of the rate control.

**Useable Adjustment Setting Range**  
Red lines are model's maximum allowable propelling force.

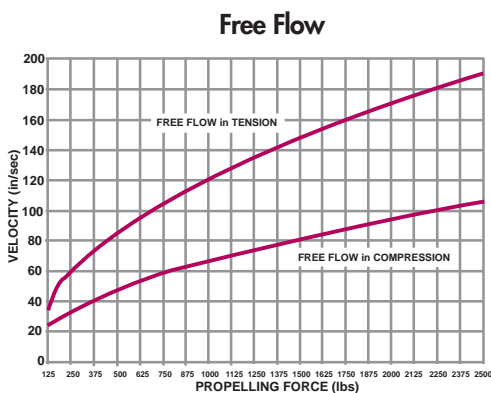
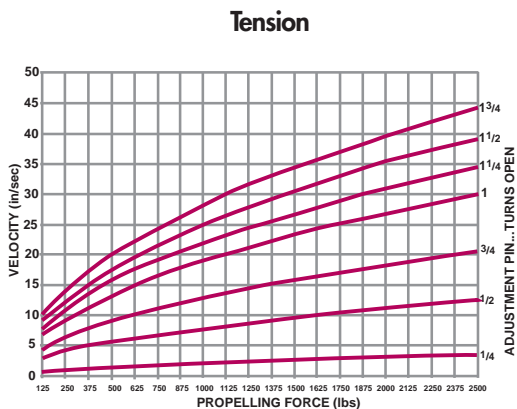
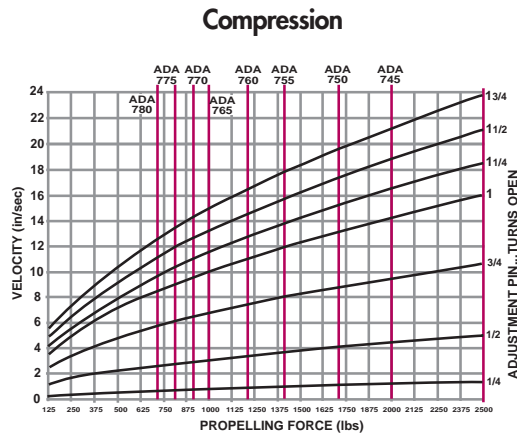

**Damping Force**



Turn adjustment pin 1 3/4 turns open to provide minimum damping force. Turn adjustment pin fully closed to provide maximum damping force.

1. To determine the approximate adjustment setting, when the selected model, propelling force, and velocity are known, compare velocity to the propelling force in the compression and/or tension mode adjustment setting curves. The intersection point of the velocity and the propelling force is the approximate adjustment setting to be used. Adjustment lower or higher than this setting will result in slower or faster damper operation respectively.
2. To determine the velocity, when the selected model, adjustment setting, and propelling force are known, compare the propelling force to the adjustment setting in the compression and/or tension mode adjustment setting curves. The intersection point of the propelling force and the adjustment setting is the approximate velocity for the selected model. Higher velocities are obtained at higher adjustment settings and lower velocities are obtained at lower adjustment settings.
3. A 1.5mm Hex Wrench (provided) is required to adjust the unit.

**NOTE:** When a free flow plug is used, the intersection point of the propelling force and free flow plug curve determines the velocity.

**EXAMPLE: Adjustable Double Acting Rate Control Application**

Stroke required: 6 in. (152 mm)  
Control direction: Tension and Compression  
Propelling force: 1,000 lbs. (4 4448 N) (tension),  
1,625 lbs. (7 228 N) (compression)

- Selection: ADA 715
1. Velocity: 25 in./sec. (0,635 m/s) (tension),  
4 in./sec. (0,1 m/s) (compression)
- Intersection point: Adjustment setting 1 1/2 (tension),  
1/2 (compression)
2. Adjustment setting: 1 1/2 (tension), 1/2 (compression)
- Velocity: 25 in./sec. (0,635 m/s) (tension),  
4 in./sec. (0,1 m/s) (compression)

**NOTE:** Propelling force and velocity should be measured at the location of the rate control.



*Assembly Applications*

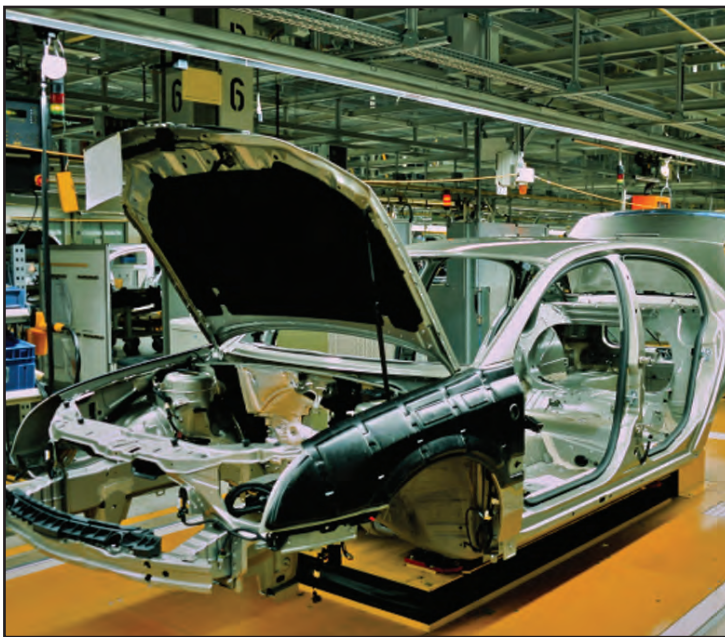

*Automotive Manufacturing Applications*



*Printing Presses*

ADA 505 → ADA 525 Series

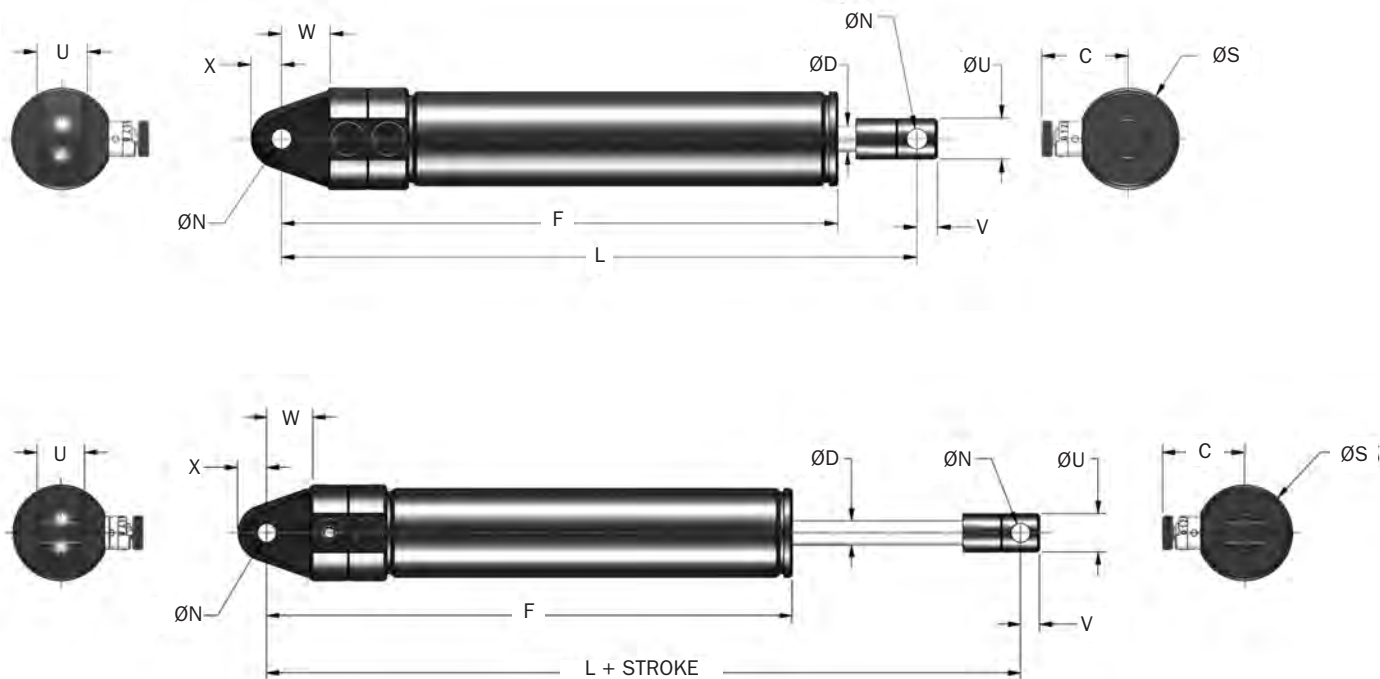

Catalog No./ Model	Damping Direction	Bore Size in. (mm)	(S) Stroke in. (mm)	(F <sub>D</sub> ) Max. Propelling Force		(E <sub>T-C</sub> ) Max. in.-lbs./hour (Nm/hr)	Model Weight lbs. (Kg)
				Extension lbs. (N)	Compression lbs. (N)		
ADA 505	T, C or T and C	.63	2	450	450	650,000	0.68
ADA 505M		(16,0)	(50,0)	(2 000)	(2 000)	(73 450)	(0,3)
ADA 510	T, C or T and C	.63	4	450	375	850,000	0.80
ADA 510M		(16,0)	(100,0)	(2 000)	(1 670)	(96 050)	(0,372)
ADA 515	T, C or T and C	.63	6	450	300	1,050,000	1.0
ADA 515M		(16,0)	(150,0)	(2 000)	(1 335)	(118 650)	(0,445)
ADA 520	T, C or T and C	.63	8	450	200	1,250,000	1.1
ADA 520M		(16,0)	(200,0)	(2 000)	(900)	(141 250)	(0,520)
ADA 525	T, C or T and C	.63	10	450	125	1,450,000	1.3
ADA 525M		(16,0)	(250)	(2 000)	(550)	(163 850)	(0,590)

Catalog No./ Model	C in. (mm)	D in. (mm)	F in. (mm)	L in. (mm)	N +.005/-0.000 +0,13/-0,00 in. (mm)	S in. (mm)	U +.000/-0.010 +0,00/-0,381 in. (mm)	V in. (mm)	W in. (mm)	X in. (mm)	(S) Stroke in. (mm)	Damping Direction in. (mm)
ADA 505	1.06	.31	6.87	7.81	.251	1.25	.500	.25	.563	.375	2	T, C or T and C
ADA 505M	(27,0)	(8,0)	(173,0)	(200)	(6,0)	(31,8)	(12,7)	(6,3)	(14,2)	(9,5)	(50,0)	
ADA 510	1.06	.31	8.87	9.81	.251	1.25	.500	.25	.563	.375	4	T, C or T and C
ADA 510M	(27,0)	(8,0)	(224,0)	(250)	(6,0)	(31,8)	(12,7)	(6,3)	(14,2)	(9,5)	(100,0)	
ADA 515	1.06	.31	10.87	11.81	.251	1.25	.500	.25	.563	.375	6	T, C or T and C
ADA 515M	(27,0)	(8,0)	(275,0)	(300)	(6,0)	(31,8)	(12,7)	(6,3)	(14,2)	(9,5)	(150,0)	
ADA 520	1.06	.31	12.87	13.81	12.87	1.25	.500	.25	.563	.375	8	T, C or T and C
ADA 520M	(27,0)	(8,0)	(325,0)	(350)	(6,0)	(31,8)	(12,7)	(6,3)	(14,2)	(9,5)	(200,0)	
ADA 525	1.06	.31	14.87	15.81	.251	1.25	.500	.25	.563	.375	10	T, C or T and C
ADA 525M	(27,0)	(8,0)	(376,0)	(400)	(6,0)	(31,8)	(12,7)	(6,3)	(14,2)	(9,5)	(250,0)	

ADA 705 → ADA 735 Series

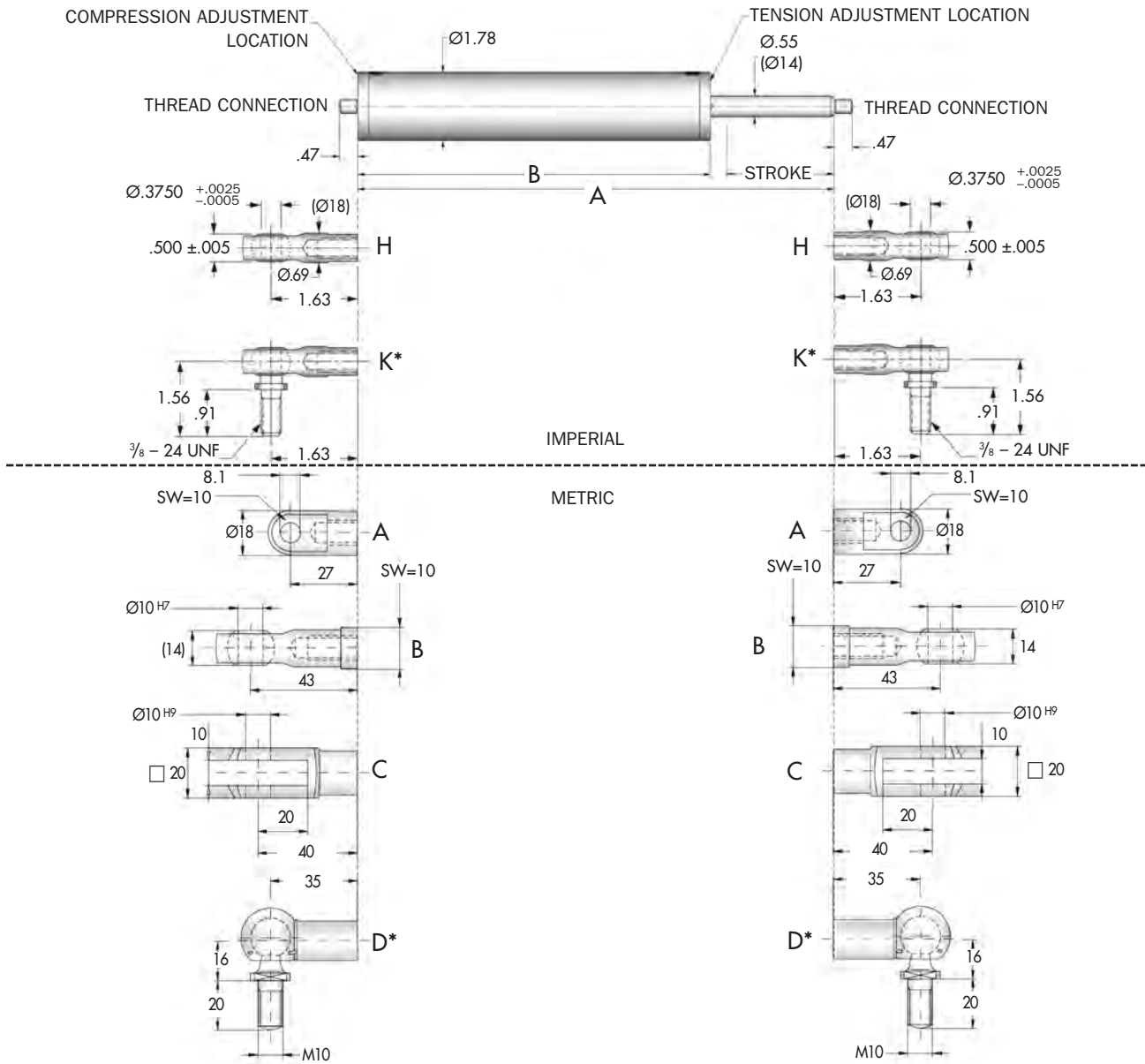

Catalog No./ Model	Damping Direction	Bore Size in. (mm)	(S) Stroke in. (mm)	(F <sub>D</sub> ) Max. Propelling Force		(E, C) Max in.-lbs./hour (Nm/hr)	Model Weight lbs. (Kg)	A in. (mm)	B in. (mm)
				Tension lbs. (N)	Compression lbs. (N)				
ADA 705	T, C or T and C	.98 (25)	2 (50,0)	2,500 (11 000)	2,500 (11 000)	1,100,000 (129 000)	3.5 (1,6)	9.35 (237)	7.10 (180)
ADA 710	T, C or T and C	.98 (25)	4 (100,0)	2,500 (11 000)	2,500 (11 000)	1,400,000 (168 000)	4.4 (2,0)	13.35 (339)	9.10 (231)
ADA 715	T, C or T and C	.98 (25)	6 (150,0)	2,500 (11 000)	2,500 (11 000)	1,800,000 (206 000)	5.1 (2,3)	17.35 (441)	11.10 (282)
ADA 720	T, C or T and C	.98 (25)	8 (200,0)	2,500 (11 000)	2,500 (11 000)	2,100,000 (247 000)	5.7 (2,6)	21.30 (541)	13.10 (332)
ADA 725	T, C or T and C	.98 (25)	10 (250,0)	2,500 (11 000)	2,500 (11 000)	2,500,000 (286 000)	6.4 (2,9)	25.30 (643)	15.10 (383)
ADA 730	T, C or T and C	.98 (25)	12 (300,0)	2,500 (11 000)	2,500 (11 000)	2,800,000 (326 000)	7.1 (3,2)	29.35 (745)	17.10 (434)
ADA 735	T, C or T and C	.98 (25)	14 (350,0)	2,500 (11 000)	2,500 (11 000)	3,200,000 (366 000)	7.9 (3,6)	33.35 (847)	19.10 (485)

\*Notes: 1. The maximum load capacity for mounting option K and D is 650 lbs.  
 2. The maximum load capacity for mounting option K and D is 1 600 N

ADA 740 → ADA 780 Series

COMPRESSION ADJUSTMENT  
LOCATION

TENSION ADJUSTMENT LOCATION

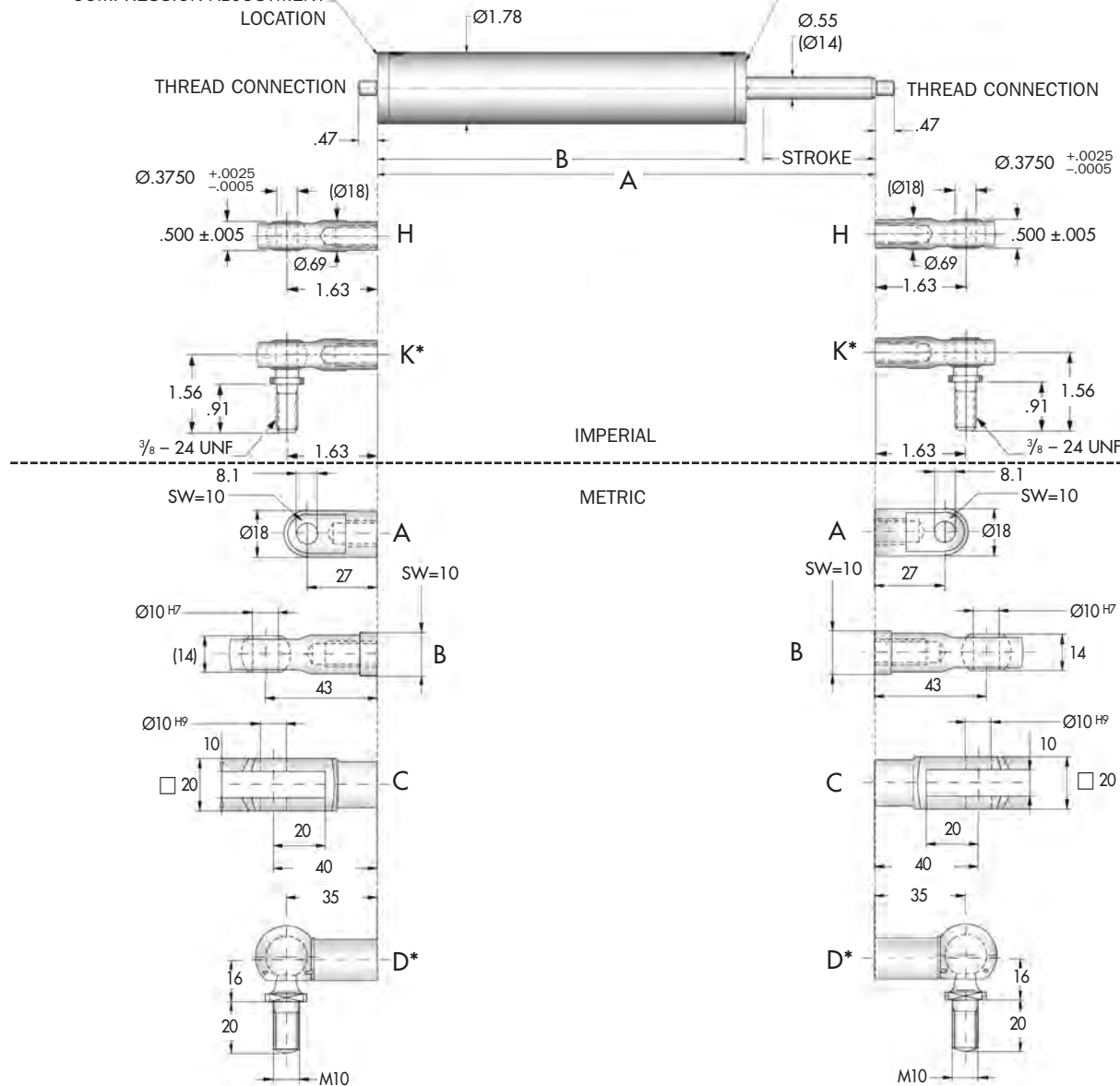

Catalog No./Model	Damping Direction	Bore Size in. (mm)	(S) Stroke in. (mm)	(F <sub>D</sub> ) Max. Propelling Force		(E <sub>T</sub> C) Max in.-lbs./hour (Nm/hr)	Model Weight lbs. (Kg)	A in. (mm)	B in. (mm)
				Tension lbs. (N)	Compression lbs. (N)				
ADA 740	T, C or T and C	.98 (25,0)	16 (400)	2,500 (11 000)	2,500 (11 000)	3,500,000 (405 000)	8.6 (3,9)	37.30 (947)	21.10 (535)
ADA 745	T, C or T and C	.98 (25,0)	18 (450)	2,500 (11 000)	2,000 (8 800)	3,900,000 (444 000)	9.3 (4,2)	41.30 (1 049)	23.10 (586)
ADA 750	T, C or T and C	.98 (25,0)	20 (500)	2,500 (11 000)	1,700 (7 500)	4,200,000 (484 000)	9.9 (4,5)	45.30 (1 151)	25.10 (637)
ADA 755	T, C or T and C	.98 (25,0)	22 (550)	2,500 (11 000)	1,400 (6 200)	4,600,000 (524 000)	10.6 (4,8)	49.35 (1 253)	27.10 (688)
ADA 760	T, C or T and C	.98 (25,0)	24 (600)	2,500 (11 000)	1,200 (5 300)	4,900,000 (563 000)	11.5 (5,2)	53.35 (1 355)	29.10 (739)
ADA 765	T, C or T and C	.98 (25,0)	26 (650)	2,500 (11 000)	1,000 (4 500)	5,300,000 (603 000)	12.1 (5,5)	57.35 (1 457)	31.10 (790)
ADA 770	T, C or T and C	.98 (25,0)	28 (700)	2,500 (11 000)	900 (4 000)	5,600,000 (642 000)	12.8 (5,8)	61.30 (1 557)	33.10 (840)
ADA 775	T, C or T and C	.98 (25,0)	30 (750)	2,500 (11 000)	800 (3 500)	6,000,000 (681 000)	13.4 (6,1)	65.30 (1 659)	35.10 (891)
ADA 780	T, C or T and C	.98 (25,0)	32 (800)	2,500 (11 000)	700 (3 100)	6,300,000 (721 000)	14.3 (6,5)	69.35 (1 761)	37.10 (942)

\*Notes: 1. The maximum load capacity for mounting option for K and D is 650 lbs. 2. The maximum load capacity for mounting option for K and D is 1 600 N.



**Remote Adjustment Cable for ADA 500 Series**

ITT Enidine will custom fit a remote adjustment cable for applications where the ADA unit will be mounted in non-accessible locations. Contact ITT Enidine for more information.

Note: If rotary application, please complete application worksheet on page 104 and forward to Enidine.



Standard remote adjustment cable length is 48" (1220 mm). Optional lengths available upon request.  
Note: Remote adjustment cable can be used in a single position only.

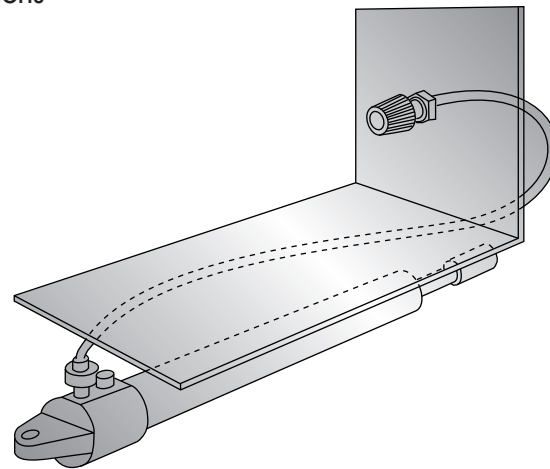

Adjustable Cartridge

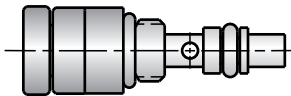

Free Flow Plug

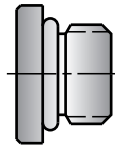

Non-Adjustable Cartridge

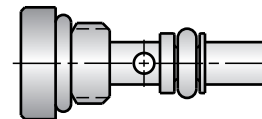

Catalog No.	Part Number	Accessory Description	LA in. (mm)	Weight oz. (g)
<b>RAC48</b>	1K495748	Remote Adjustment Cable	48 (1220)	7 (191)
<b>RAC4957</b>	AJ4957325	Adjustable Cartridge	<p><b>Notes</b></p> <p>"x" specify desired setting "0-6". May be used in place of adjustable cartridge.</p> <p>For installing adjustable and non-adjustable cartridges.</p> <p>Provides least amount of damping force for ADA Models.</p>	
<b>NAC "x"</b>	NJ"x"4957327	Non-Adjustable Cartridge (0-6)		
<b>CW4957</b>	2L4957302	Cartridge Wrench		
<b>FFP4957</b>	PA4957326	Free Flow Plug		

DA 705 → DA720 Series

DA 75M x 50 → DA 75M x 100 Series

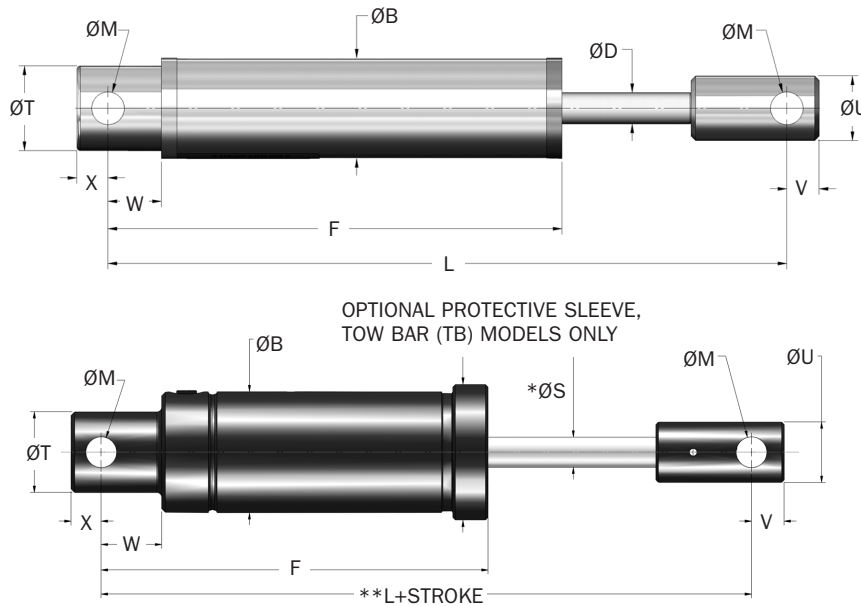

Catalog No./ Model	Damping Direction	Bore Size in. (mm)	(S) Stroke in. (mm)	(F <sub>p</sub> ) Max. Propelling Force lbs. (N)	(E <sub>T</sub> ) Max. in.-lbs./cycle (Nm/cycle)	(E <sub>T</sub> C) Max. in.-lbs./hr (Nm/cycle)	Model Weight lbs. (Kg)
DA 705	T, C or T and C	.98 (25,0)	2 (50,0)	2,500 (11 000)	—	1,100,000 (129 000)	3.5 (1,6)
DA 710	T, C or T and C	.98 (25,0)	4 (100,0)	2,500 (11 000)	—	1,400,000 (168 000)	4.4 (2,0)
DA 715	T, C or T and C	.98 (25,0)	2 (50,0)	2,500 (11 000)	—	1,800,000 (206 000)	5.1 (2,3)
DA 720	T, C or T and C	.98 (25,0)	4 (100,0)	2,500 (11 000)	—	2,100,000 (247 000)	5.7 (2,6)
DA 75 x 2	T, C or T and C	1.50 (38,0)	2 (50,0)	5,000 (22 250)	10,000 (1 120)	2,700,000 (305 000)	25.0 (11,4)
DA 75M x 50	T, C or T and C	1.50 (38,0)	4 (100,0)	5,000 (22 250)	20,000 (2 240)	3,100,000 (350 000)	29.0 (13,2)

Catalog No./ Model	B in. (mm)	D in. (mm)	F in. (mm)	L in. (mm)	M ±.015 (±0,38) in. (mm)	S in. (mm)	T ±.015 (±0,38) in. (mm)	U ±.010 (±0,25) in. (mm)	V in. (mm)	W in. (mm)	X in. (mm)	(S) Stroke in. (mm)
DA 705	1.77 (45,0)	.55 (14,0)	8.04 (255,1)	12.09 (307,1)	.579 (14,7)	—	1.50 (38,0)	1.14 (29,0)	.571 (14,5)	.945 (24,0)	.551 (14,0)	2 (50,0)
DA 710	1.77 (45,0)	.55 (14,0)	10.04 (255,1)	16.11 (409,1)	.579 (14,7)	—	1.50 (38,0)	1.14 (29,0)	.571 (14,5)	.945 (24,0)	.551 (14,0)	4 (100,0)
DA 715	1.77 (45,0)	.55 (14,0)	12.05 (306,1)	20.12 (511,1)	.579 (14,7)	—	1.50 (38,0)	1.14 (29,0)	.571 (14,5)	.945 (24,0)	.551 (14,0)	6 (150,0)
DA 720	1.77 (45,0)	.55 (14,0)	14.02 (356,1)	24.06 (611,1)	.579 (14,7)	—	1.50 (38,0)	1.14 (29,0)	.571 (14,5)	.945 (24,0)	.551 (14,0)	8 (200,0)
DA 75 x 2	3.00 (76,0)	0.75 (19,0)	9.58 (245)	13.75 (348)	.765 (19,4)	3.38 (86,0)	2.00 (51,0)	1.500 (38,0)	.81 (21,0)	1.50 (38,0)	.75 (19,0)	2 (50,0)
DA 75M x 50	3.00 (76,0)	0.75 (19,0)	11.58 (295)	15.75 (398)	.765 (19,4)	3.38 (86,0)	2.00 (51,0)	1.500 (38,0)	.81 (21,0)	1.50 (38,0)	.75 (19,0)	4 (100,0)

- Notes: 1. DA Models will function at 10% of their maximum rated energy per cycle. If less than 10%, a smaller model should be specified.  
 2. Provide a positive stop 12 in. before end of stroke in tension and compression to prevent internal bottoming.  
 3. For optimal performance in vertical applications using compression, mount the rate control with the piston rod down.  
 4. \* ØS indicates outside diameter of optional protective sleeve for TB models.  
 5. \*\* Dimension L is controlled by a 2.0 in. stroke limiter.

# Rate Controls

## DA Series

### Technical Data

DA 75 x 6 → TB 100 x 6 Series

DA 75M x 150 → DA 75M x 250 Series

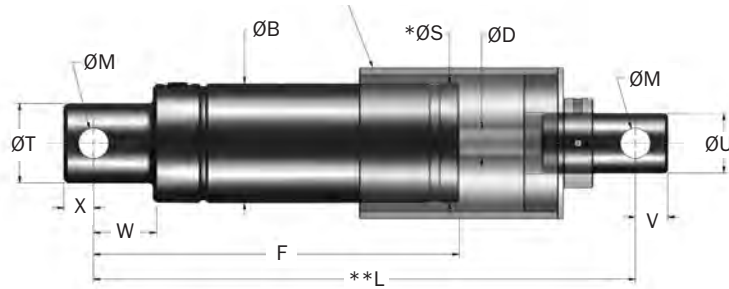
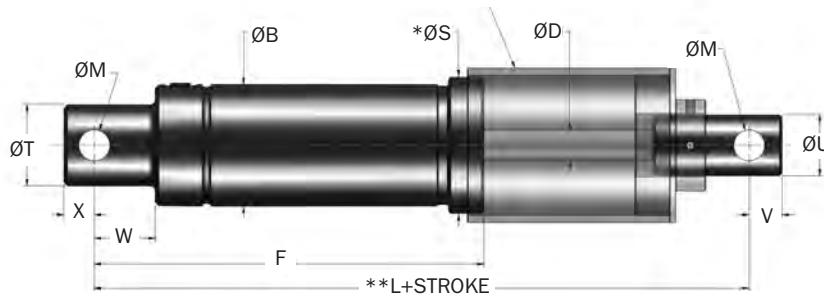
OPTIONAL PROTECTIVE SLEEVE,  
TOW BAR (TB) MODELS ONLYOPTIONAL PROTECTIVE SLEEVE,  
TOW BAR (TB) MODELS ONLY

Catalog No./ Model	Damping Direction	Bore Size in. (mm)	(S) Stroke in. (mm)	(F <sub>D</sub> ) Max. Propelling Force lbs. (N)	(E <sub>T</sub> ) Max. in.-lbs./cycle (Nm/cycle)	(E <sub>T</sub> C) Max. in.-lbs./hr (Nm/cycle)	Model Weight lbs. (Kg)
DA 75 x 6 DA 75M x 100	T, C or T and C	1.50 (38,0)	6 (150,0)	5,000 (22 250)	30,000 (3 360)	3,600,000 (406 000)	33.0 (15,0)
DA 75 x 8 DA 75M x 150	T, C or T and C	1.50 (38,0)	8 (200,0)	5,000 (22 250)	40,000 (4 480)	4,100,000 (463 000)	37.0 (16,8)
DA 75 x 10 DA 75M x 250	T, C or T and C	1.50 (38,0)	10 (250,0)	5,000 (22 250)	50,000 (5 600)	4,500,000 (508 000)	41.0 (18,6)
TB 100 x 4	T and C	2.25 (57,2)	4 (100,0)	10,000 (44 482)	40,000 (4 480)	4,400,000 (497 133)	32.0 (14,5)
TB 100 x 6	T and C	2.25 (57,2)	6 (150,0)	10,000 (44 482)	60,000 (6 779)	4,400,000 (497 133)	32.0 (14,5)

Catalog No./ Model	B in. (mm)	D in. (mm)	F in. (mm)	L in. (mm)	M ±.015 (±0,38) in. (mm)	S in. (mm)	T ±.015 (±0,38) in. (mm)	U ±.010 (±0,25) in. (mm)	V in. (mm)	W in. (mm)	X in. (mm)	(S) Stroke in. (mm)
DA 75 x 6	3.00	0.75	13.58	17.75	.765	3.38	2.00	1.500	.81	1.50	.75	6
DA 75M x 100	(76,0)	(19,0)	(345)	(448)	(19,4)	(86,0)	(51,0)	(38,0)	(21,0)	(38,0)	(19,0)	(150,0)
DA 75 x 8	3.00	0.75	15.58	19.75	.765	3.38	2.00	1.500	.81	1.50	.75	8
DA 75M x 150	(76,0)	(19,0)	(395)	(498)	(19,4)	(86,0)	(51,0)	(38,0)	(21,0)	(38,0)	(19,0)	(200,0)
DA 75 x 10	3.00	0.75	17.58	21.75	.765	3.38	2.00	1.500	.81	1.50	.75	10
DA 75M x 250	(76,0)	(19,0)	(445)	(548)	(19,4)	(86,0)	(51,0)	(38,0)	(21,0)	(38,0)	(19,0)	(250,0)
TB 100 x 4	2.75 (70,0)	1.00 (25,4)	18.88 (480)	24.25** (616)	.750 (19,1)	3.25* (82,6)	2.50 (63,5)	1.500 (38,0)	.75 (19,1)	1.75 (38,0)	.75 (19,0)	4 (100,0)
TB 100 x 6	2.75 (70,0)	1.00 (25,4)	18.88 (480)	22.25** (565)	.750 (19,1)	3.25* (82,6)	2.50 (63,5)	1.500 (38,0)	.75 (19,1)	1.75 (38,0)	.75 (19,0)	6 (150,0)

Notes: 1. DA Models will function at 10% of their maximum rated energy per cycle. If less than 10%, a smaller model should be specified.

2. Provide a positive stop 12 in. before end of stroke in tension and compression to prevent internal bottoming.

3. For optimal performance in vertical applications using compression, mount the rate control with the piston rod down.

4. \* ØS indicates outside diameter of optional protective sleeve for TB models.

5. \*\* Dimension L is controlled by a 2.0 in. stroke limiter.

FAX NO.: \_\_\_\_\_  
DATE: \_\_\_\_\_  
ATTN: \_\_\_\_\_  
COMPANY: \_\_\_\_\_

The ITT Enidine Application Worksheet makes shock absorber sizing and selection easier.

Fax, phone, or mail worksheet data to Enidine headquarters or your nearest ITT Enidine subsidiary/affiliate or distributor. (See catalog back cover for ITT Enidine locations, or visit [www.enidine.com](http://www.enidine.com) for a list of ITT Enidine distributors.)

Upon ITT Enidine's receipt of this worksheet, you will receive a detailed analysis of your application and product recommendations. (For custom design projects, Enidine representatives will consult with you for specification requirements.)

### GENERAL INFORMATION

CONTACT: \_\_\_\_\_  
DEPT/TITLE: \_\_\_\_\_  
COMPANY: \_\_\_\_\_  
ADDRESS: \_\_\_\_\_  
TEL: \_\_\_\_\_ FAX: \_\_\_\_\_  
EMAIL: \_\_\_\_\_  
PRODUCTS MANUFACTURED: \_\_\_\_\_

### APPLICATION SKETCHES / NOTES

### APPLICATION DESCRIPTION

---

---

---

---

---

---

---

---

---

Motion Direction (Check One):

Horizontal  Vertical  Up  Incline Angle \_\_\_\_\_  
 Down  Height \_\_\_\_\_

Rotary Horizontal  Rotary Vertical  Up

Down \_\_\_\_\_ (lbs.)(Kg)

Cycle Rate \_\_\_\_\_ (cycles/hour)

Additional Propelling Force (If Known) \_\_\_\_\_ (lbs.)(N)

Air Cyl: Bore \_\_\_\_\_ (in.)(mm) Max. Pressure \_\_\_\_\_ (psi)(bar) Rod Dia. \_\_\_\_\_ (in.)(mm)

Hydraulic Cyl: Bore \_\_\_\_\_ (in.)(mm) Max. Pressure \_\_\_\_\_ (psi)(bar)  
Rod Dia. \_\_\_\_\_ (in.)(mm)

Motor \_\_\_\_\_ (hp)(kW) Torque \_\_\_\_\_ (in-lbs.)(Nm)

Ambient Temp. \_\_\_\_\_ °F (°C)

Environmental Considerations: \_\_\_\_\_

### SHOCK ABSORBER APPLICATION (All Data Taken at Shock Absorber)

Number of Shock Absorbers to Stop Load

Impact Velocity (min./max.) \_\_\_\_\_ (in./sec.)(m/sec.)

Shock Absorber Stroke Requirements: \_\_\_\_\_ (in.)(mm)

G Load Requirements \_\_\_\_\_ (G)(m/sec<sup>2</sup>)

Enidine is a diversified leading manufacturer of highly engineered critical components and customized technology solutions for growing industrial end-markets in energy infrastructure, electronics, aerospace and transportation.

As part of our strategy to make the customer central to everything we do, our core technologies, engineering strength and global scale offers greater value for customers in terms of quality, cost and delivery.

**Common Applications:**

- Automotive
- Auto, Storage and Retrieval
- Bridges and Structures
- Conveyor Systems
- Steel Mills
- Plastic Bottle Manufacturing
- Packaging Machinery
- Overhead Cranes
- Robotics
- Electronics Cabinets
- Sub-Sea Equipment
- Medical Equipment

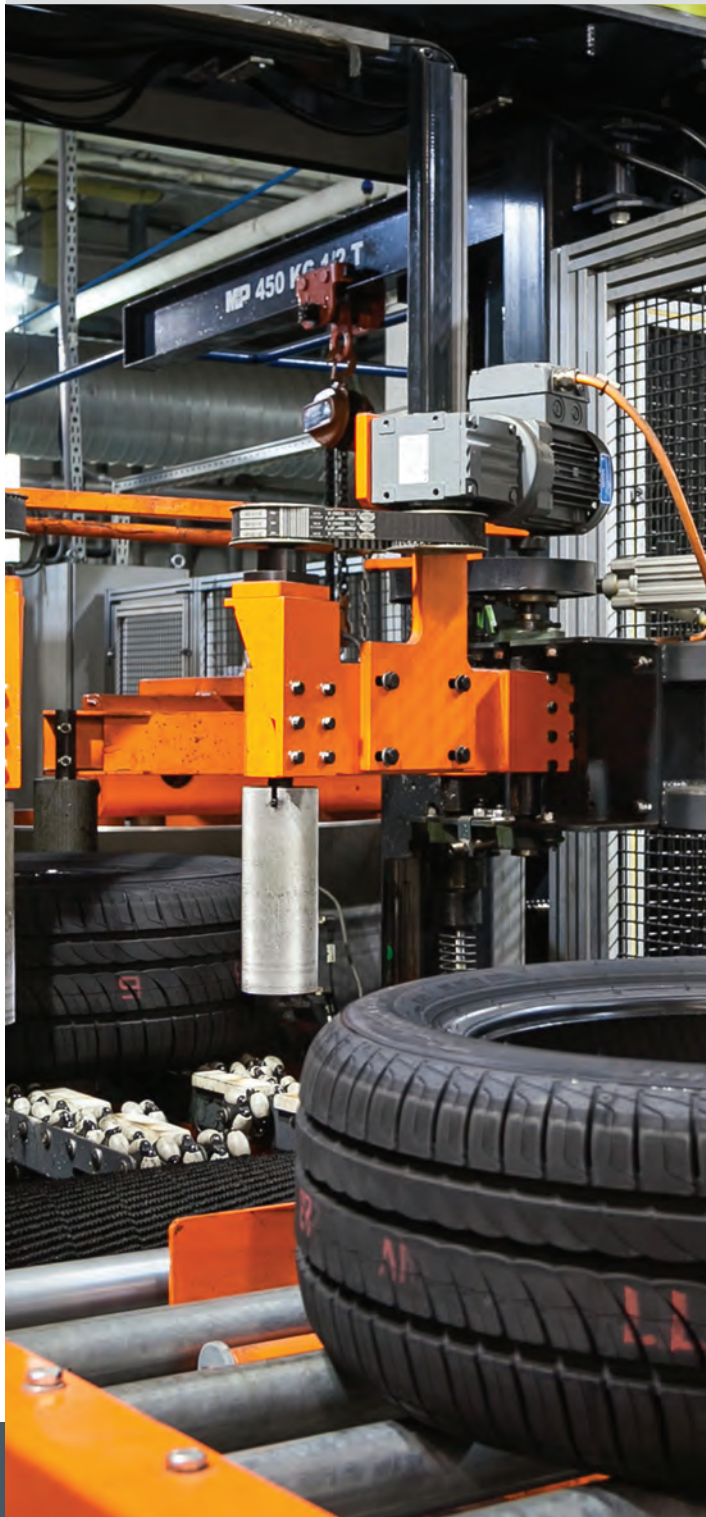

**Enidine provides energy absorption and vibration isolation solutions to meet the challenging demands of global industrial markets.**

**Enidine**

7 Centre Drive  
Orchard Park, New York 14127  
Phone: 716-662-1900  
Fax: 716-662-1909  
Email: [industrialsales@enidine.com](mailto:industrialsales@enidine.com)  
[www.enidine.com](http://www.enidine.com)

**Enidine GmbH**

Werkstrasse 5  
D-64732, Bad Koenig, Germany  
Phone: +49 6063 9314 0  
Fax: +49 6063 9314 44  
Email: [info@enidine.eu](mailto:info@enidine.eu)  
[www.enidine.eu](http://www.enidine.eu)

**ITT Control Technologies (APAC)**

570 Xida Rd., Meicun, New Dist.,  
Wuxi, China 214112  
Phone: 86 510 8855 6197  
Fax: 86 510 8855 6193  
Email: [enidineCN@itt.com](mailto:enidineCN@itt.com)  
Email: [controltechnologiesAPAC@itt.com](mailto:controltechnologiesAPAC@itt.com)  
[www.enidine.cn](http://www.enidine.cn)

**Enidine Co. Ltd.**

1-7-20 Maginu, Miyamae-ku, Kawasaki-shi  
Kanagawa-kan, 216-0035  
Japan  
Phone: 81-44-870-8112  
Fax: 81-44-870-8133  
Email: [support.enidinejp@itt.com](mailto:support.enidinejp@itt.com)  
[www.enidine.co.jp](http://www.enidine.co.jp)