

# Y12 Series - Industrial Thermometer

9" Scale / Any Angle Mount



Thermometers

Marsh Instruments Y12 Industrial Thermometers large scale 9" scale permits easy reading at longer distances. The glass-reinforced nylon case is lightweight yet rugged enough for demanding installations. The adjustable stem can be locked into any position. These thermometers are commonly used on hot or chilled water lines in commercial/industrial buildings.

## Features:

- Standard Well & Lagged Well Options
- Adjustable Angle
- Easy-to-Read Dual Scale

## Product Dimensions

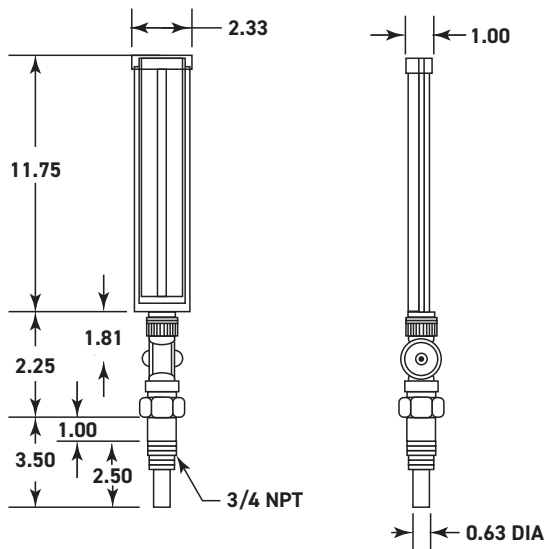

## Product Specifications

### Design

Meets/Exceeds ASME B40.100

### Accuracy

±1% of Scale Range

### Dial Size(s)

9" Length (228 mm)

### Case

Molded Black Nylon, Glass Fiber Reinforced

### Connection & Stem

Adjustable Aluminum 3 1/2" or 6" Stem with 360° Rotation

1/4" - 18 Swivel Nut, For Use with Separable Socket

### Movement

N/A

### Temperature Ranges

-40° to 300°F

### Standard Scale

Dual Scale in Celsius and Fahrenheit

### Dial Color

White Coated Aluminum

### Tube

Blue Liquid Fill

### Window

Glass