

SENTRY GS

Excess Flow Valves for Residential Installation

Complies with the German DVGW-TRGI 2018 and DVFG-TRF 2012 and the English General Gas Guidance IGE/G/5.

CE 0085



DESCRIPTION

Excess flow valves (EFVs) close, shutting off the gas flow, when a predefined flow rate is reached. Mertik Maxitrol's factory adjustment (100%) provides a precise and reliable closing flow rate. In the nominal flow range, the EFV remains in a stable, open position. The EFV is installed downstream of the main gas manual shut-off valve (ECV). If equipped with a by-pass orifice, SENTRY GS EFVs reopen after the downstream line has been repaired and re-pressurized.

Gas installation regulations in Germany require the use of excess flow valves. SENTRY GS EFVs fulfill the German requirements of the DVGW-TRGI 2018 and the DVFG-TRF 2012. SENTRY GS Series complies with the Pressure Equipment Directive (97/23/EC) and the DVGW VP 305-1; 2007 (DIN 30652-1). For EFVs to function, the gas piping must be properly sized.

SENTRY GS EFVs have been used successfully and effectively for more than 20 years in underground gas service lines and residential installations throughout the world. In Germany alone, more than 1,000,000 Mertik Maxitrol EFVs (underground and residential applications) are currently in service. For more information refer to "SENTRY GS Excess Flow Valves for Underground Gas Service Lines" available at www.mertikmaxitrol.com.

FEATURES AND ADVANTAGES

SENTRY GS type K for all Mounting Positions

K-type EFVs may be mounted either *horizontally* or *vertically* (upward gas flow code letter Z; downward gas flow code letter D). (See number code on page 4.)

Patented Damping System

Potential peaks at start-up of a gas appliance can close the EFV. Mertik Maxitrol's SENTRY GS EFV with its patented damping system will greatly reduce the number of nuisance shut-offs. This damping system is available for natural gas output ranges up to 41 kW and LPG output ranges up to 67 kW.

Operating Pressure Range 15 – 100 mbar/hPa

The EFV can be mounted upstream or downstream of the gas pressure regulator.

SENTRY GS in Combination with a Thermally Activated Shut-Off Device

The SENTRY GS..HT combines a SENTRY GS excess flow valve and a SENTRY GT thermally activated shut-off device. The thermally activated shut-off device shuts off the gas flow at 92 °C to 100 °C.

DEFINITIONS

DVGW-TRGI 2018:

German mandatory technical regulation for the planning, construction, modification and servicing of natural gas installations.

DVFG-TRF 2012:

German mandatory technical regulation for the planning, construction, modification and servicing of liquid gas (LPG) installations.

Pressure Equipment Directive (97/23/EC):

European regulation to harmonize national laws of Member States regarding the design, manufacture, testing, and conformity assessment of pressure equipment and assemblies.

DVGW VP 305-1; 2007 (DIN 30652-1):

Excerpt of DVGW-TRGI 2018 that prescribe the German standard for excess flow valves in residential installations.

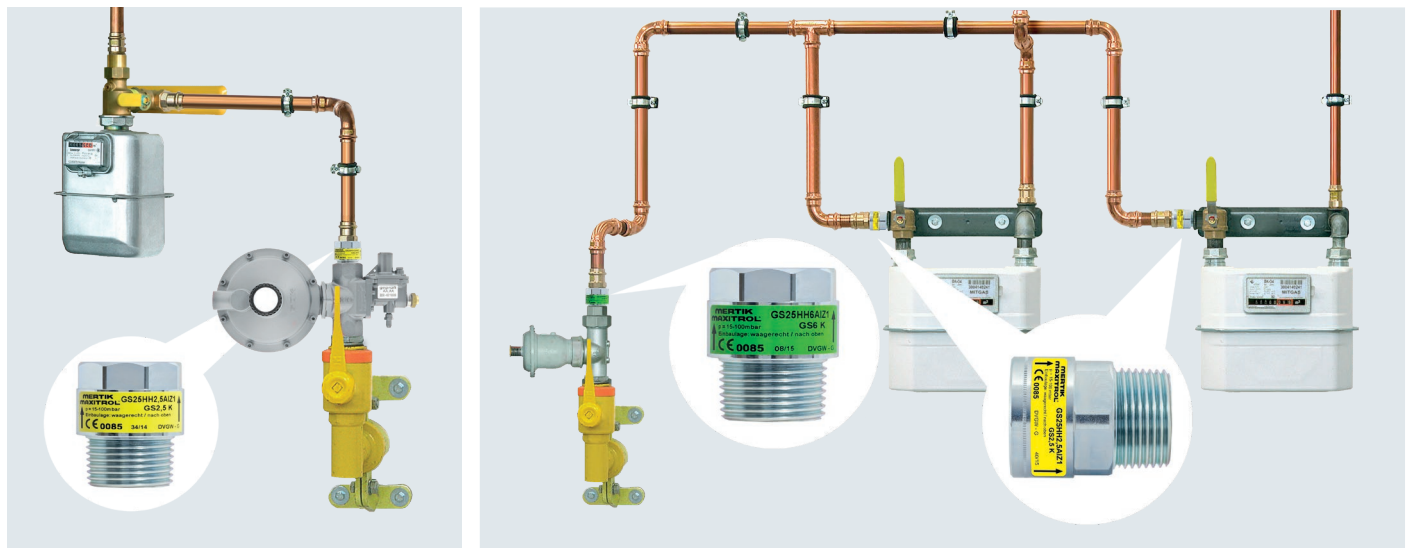

Figure 1 and 2: Installation examples of SENTRY GS excess flow valves in a single-family dwelling (left) and in a multi-family dwelling (right)

SENTRY GS in a Single-Family Dwelling

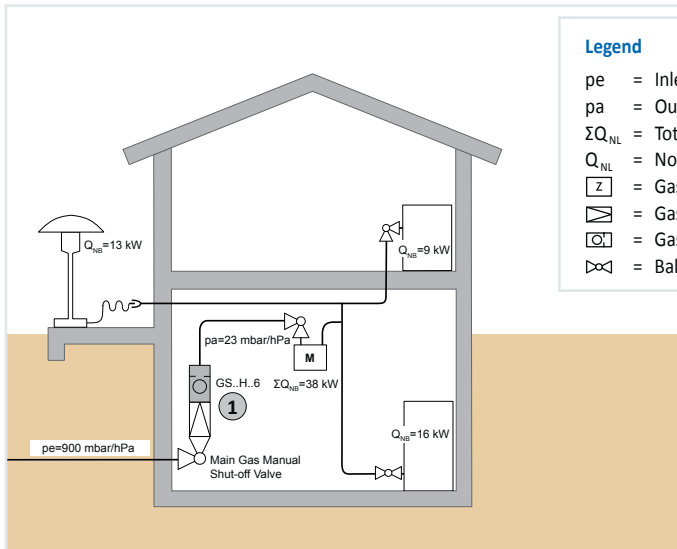

Figure 3: SENTRY GS in a single-family dwelling (supplied with natural gas)

In figure 3 a single EFV is required for an entire gas installation. It is recommended that the EFV be installed at the outlet of the gas pressure regulator (see Example 1 below).

Example

- See ① in figure 3
 - GS located downstream of main gas manual shut-off valve
 - Total nominal load of downstream appliances: $\Sigma Q_{NL} = 38 \text{ kW}$ natural gas
- Result: ① in table 1 = GS..6 (GS..H..6...)
- Most single-family dwellings in Germany use a main gas manual shut-off valve of a nominal diameter of DN25 with an internal thread as an outlet connection. The correct type in this case is SENTRY GS25HH6AIZ (see example stock number code, page 4).

SENTRY GS in a Multi-Family Dwelling

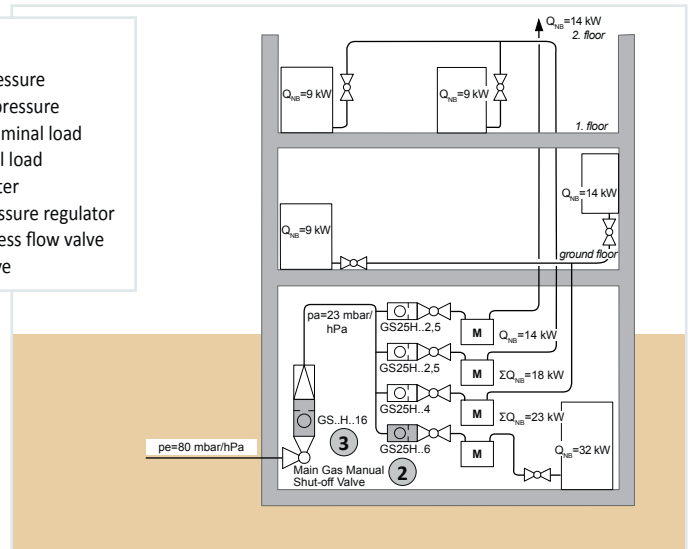

Figure 4: SENTRY GS in a multi-family dwelling (supplied with natural gas)

It is recommended that a GS EFV be installed at the main gas manual shut-off valve outlet (see Example 2 below). GS EFVs should also be installed at each gas meter, upstream of the gas meter ball valve (see Example 3 below).

Example

- See ③ in figure 4
 - GS located downstream of the main gas manual shut-off valve and upstream of the gas pressure regulator.
 - Total nominal load: $\Sigma Q_{NL} = 87 \text{ kW}$ natural gas
 - See ② in figure 4
 - GS located directly upstream of the gas meter ball valve and the gas meter.
 - Nominal load: $Q_{NL} = 32 \text{ kW}$ natural gas.
- Result: ③ in table 1 = GS..16 (GS..H..16...)
- Result: ② in table 1 = GS..6 (GS25HH6...)

Metal Piping

Selection SENTRY GS K	One gas appliance Q_{NB} [kW]	Several gas appliances ΣQ_{NB} [kW]	Minimum nominal size* for GS K (*maximum 10 m)			
			Cu, Stainless steel d_s	Steel pipe DN	Corrugated pipe DN	Gas controls DN
GS..2.5	≤ 17	≤ 21				
GS..4	18 to 27	22 to 34				
GS..6	28 to 41	35 to 51	18	20	20	15
GS..10	42 to 68	52 to 86	22	20	25	20
GS..16	69 to 110	87 to 138	28	25	32	25

Table 1: Excerpt from TRGI 2018

LPG Installation

Selection SENTRY GS K	One gas appliance Q_{NB} [kW]	Several gas appliances ΣQ_{NB} [kW]	Minimum nominal size		
			Cu, Stainless steel d_a	Precision steel pipe DN	Steel pipe DN
GS..1.6	≤ 18	≤ 25	12	12 x 1	10
GS..2.5	19 to 28	26 to 40	15	15 x 1.5	10
GS..4	29 to 45	41 to 64	15	18 x 1.5	15
GS..6	46 to 67	65 to 96	18	22 x 1.5	20
GS..10	68 to 112	97 to 160	22	28 x 2	25

Table 2: Excerpt from TRF 2012

SIZING NOTES ACCORDING TO GERMAN DVGW-WORKING PAPER G 600 (TRGI 2018) TRF

SENTRY GS EFVs are selected by determining the total nominal load of all gas appliances. The nominal load Q_{NL} – as described in article 7.2.1 of TRGI and article 7.11.2 of TRF 2012 – is according to the gas appliance technical literature or the rating plate on the gas appliance. SENTRY GS EFVs fulfill the requirements of the DVGW-TRGI and the DVFG-TRF.

SENTRY GS may also be used with plastic piping (NOTE: Plastic piping is only allowed in certain countries.). For plastic piping installations, Mertik Maxitrol offers the SENTRY GS..HT, a combination thermally activated shut-off device and EFV. Mertik Maxitrol also has a complete range of Type K EFVs with a closing flow rate 1.45 times that of nominal flow rate.

INSTALLATION EXAMPLES ACCORDING TO GERMAN TRGI 2018

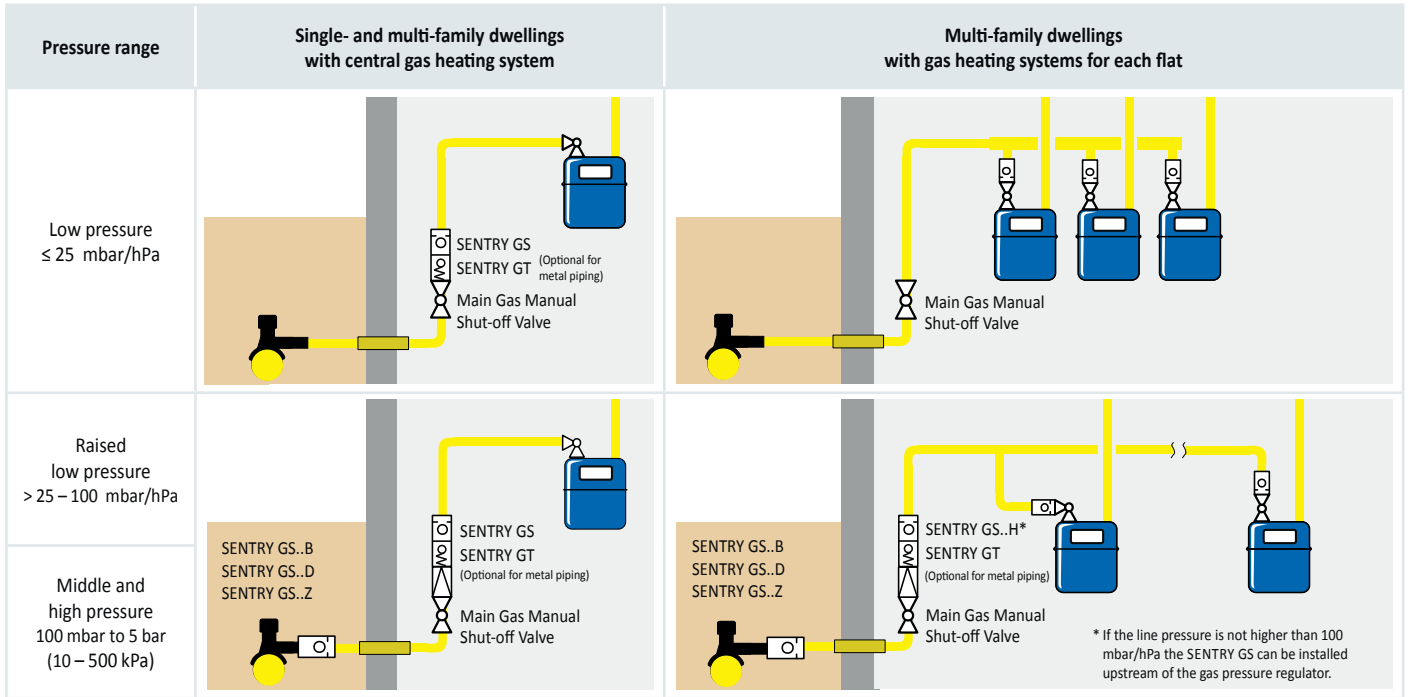

Figure 5: Installation examples with SENTRY GS excess flow valves according to German TRGI 2018

INSTALLATION EXAMPLES ACCORDING TO GERMAN TRF 2012

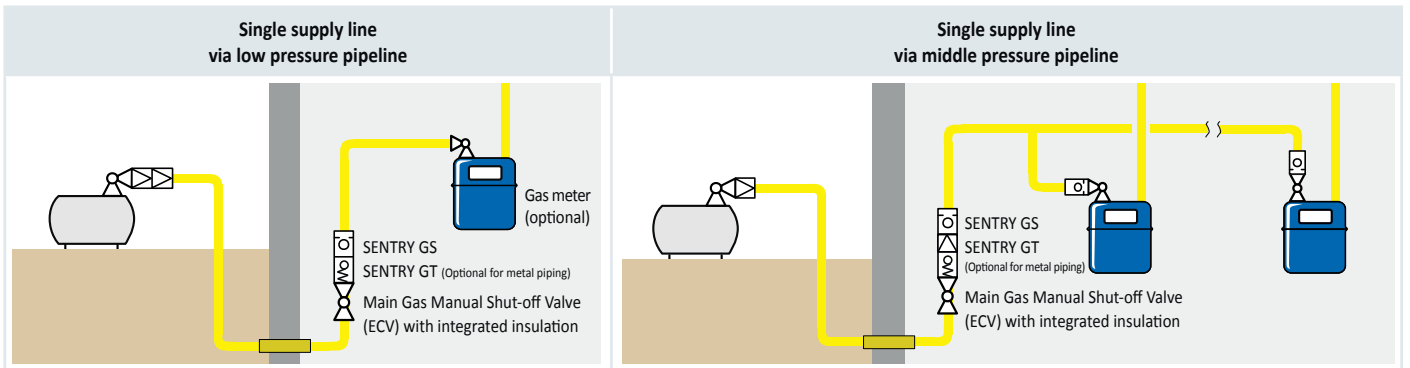

Figure 6: Installation examples with SENTRY GS excess flow valves according to German TRF 2012

CONFIGURATION

Excess flow valve SENTRY GS	GS..H..AI.	GS..H..IA.	GS..HT..AI. in combination with a thermally activated shut-off device
Nominal size	DN15, DN20, DN25, DN32, DN40, DN50	DN20, DN25, DN32, DN40, DN50	DN20, DN25
Gas inlet	Male thread A	Female thread I	Male thread A
Gas outlet	Female thread I	Male thread A	Female thread I

CLOSING FACTOR

Closing factor	Type pursuant to DVGW VP 305-1	Mounting position	SENTRY GS Configuration
$f_{s \max} \leq 1.45$	Type K	Horizontal or upward	GS..H..Z
		Downward	GS20H..D / GS25H..D

NOMINAL FLOW RATE

Nominal flow rate	DN15	DN20	DN25	DN32	DN40	DN50
V_{Gas} natural gas [m ³ /h]; d = 0.64	1.6 / 2.5	1.6 / 2.5 / 4	1.6 / 2.5 / 4 / 6	10	16	16

Legend

$$f_{s \max} = \text{Closing factor} = \frac{\text{max. closing flow rate}}{\text{nominal flow rate}} \quad V_{\text{Gas}} = \text{Nominal flow rate}$$

CUTAWAY SENTRY GS TYPE H (DN25)

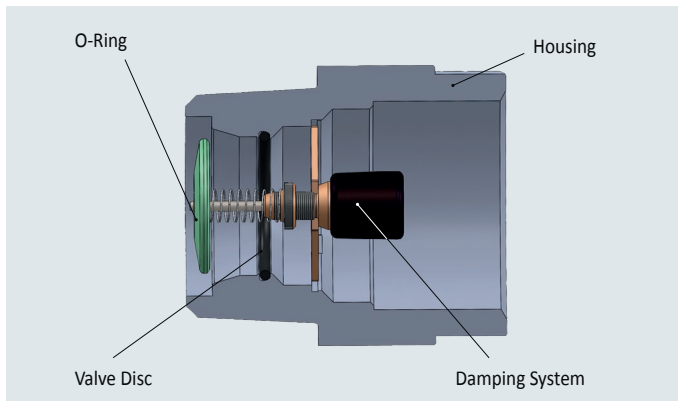

PRESSURE DROP

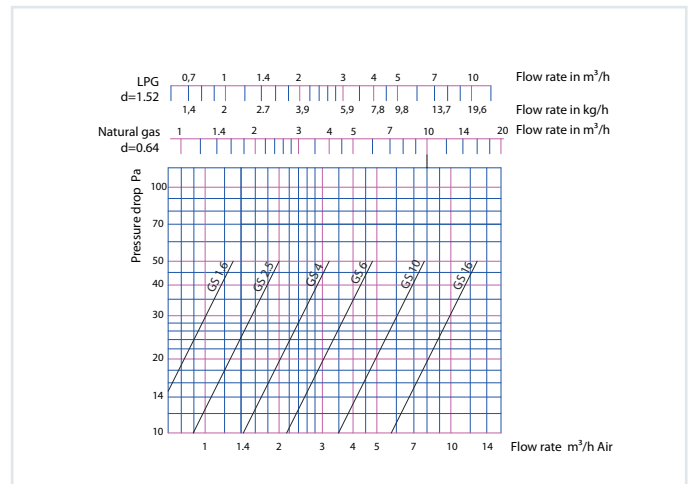

DIMENSIONS

DN	Threads according to DIN EN 10226-1 (ISO 7-1)		Version GS..H..AI			Type GS..H..IA			Type GS..HT..AI		
	Male thread	Female thread	WS	L1	L2	WS	L1	L2	L1	L2	L3
15	R ½	Rp ½	27	58	43	---	---	---	---	---	---
20	R ¾	Rp ¾	32	43	27	32	50	34	ca. 72.5	16.3	16.5
25	R 1	Rp 1	38	46.5	27.5	36	52.5	33.5	ca. 89.5	19.1	19.3
32	R 1 ¼	Rp 1 ¼	46	70	46	46	70	46	---	---	---
40	R 1 ½	Rp 1 ½	50	78	54	50	78	54	---	---	---
50	R 2	Rp 2	65	82	54	65	82	54	---	---	---

Wrench Size (WS)

TECHNICAL DATA

All values shown are for natural gas (d = 0.64). SENTRY GS EFVs are certified according to the German Standard DVGW VP 305-1; 2007 (DIN 30652-1) (DVGW-Registration-No.: DG-4663B00118) and the Pressure Equipment Directive (CE 0085). SENTRY GS EFVs for residential installations are normally equipped with a by-pass orifice allowing the GS to reopen after the downstream line has been repaired and repressurized. Close the nearest gas manual shut-off valve to speed resetting of the EFV.

Gases: Natural gas, propane gas and butane gas according to DVGW worksheet G 260 (DIN EN 437)

Installation:

TRGI: Downstream of the service regulator. If $p \leq 100$ mbar/hPa, upstream of the service regulator

TRF: Upstream of the 2nd stage of the gas pressure regulation

Operating Pressure Range: 15 – 100 mbar/hPa

Pressure Drop: ≤ 0.5 mbar/hPa (see diagram above)

Maximum Capacity: 138 kW for natural gas
160 kW for LPG

Impulse Damping System: DN 15 – 25

By-pass Orifice: Standard

By-pass Flow: 2 to 30 l/h air

Thermal Resistance: 650 °C, up to 5 bar (500 kPa) (external thermal resistance)

Ambient Temperature: - 20 °C to + 60 °C

Thread Connection: According to DIN EN 10226-1 (ISO 7-1), tapered male and straight female threads

NUMBER CODE: SENTRY GS EXCESS FLOW VALVE

