

EN

## SMARTDRIVE VF1000 · Series S

Frequency Inverter 0.375 to 0.75 W

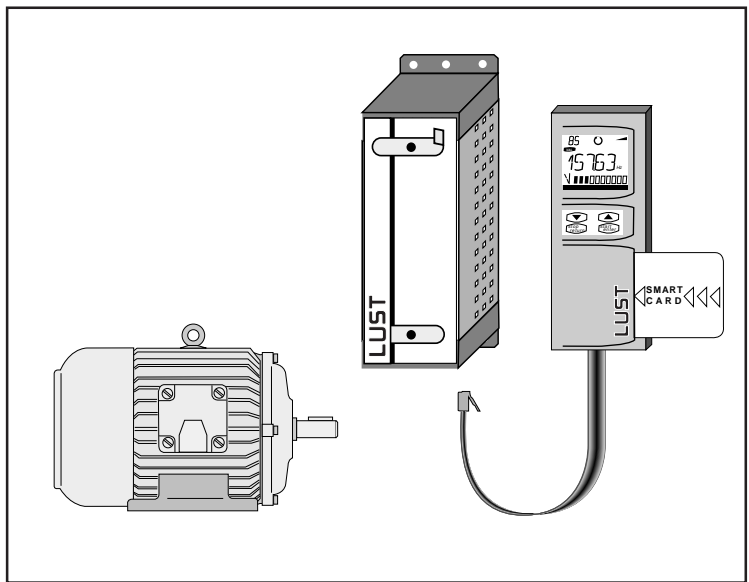

Operation Manual  
for static  
frequency inverter

**1 x 110 V - Version**

VF1104S - 375 W

**1 x 230 V - Version**

VF1202S - 375 W

VF1204S - 750 W

**3 x 400 V - Version**

VF1402S - 750 W

Applies as from software edition V1.6

ID No.: 0720.21B.2 - 01

Issued: September 1998

Dear customer!

Thank you for the trust which you have placed in us at Lust Antriebstechnik GmbH by purchasing the SMARTDRIVE frequency inverter.

Installation and commissioning should be carried out by a trained engineer. Please take the time to read this Operation Manual carefully before starting work. If you follow all the instructions, you will save yourself much time and many questions during the commissioning stage.

It is essential to read this Operation Manual because both the inverter itself and further components of the system can be damaged by improper handling.

If after reading the manual, however, you still have questions, do please contact us as given below.

Lust Antriebstechnik GmbH  
Gewerbestr. 5-9  
D-35633 Lahnau  
Phone: +49 64 41 966 -0  
Fax: +49 64 41 966 -137

## A Useful information on the Operation Manual

The details in this manual apply for all frequency inverters belonging to the SMARTDRIVE VF1000S family of devices.

The Information Manual is made up of 6 chapters that are listed under the heading "Signposts to Success".

Section A contains information on device variants and safety instructions. Chapters 1, 2 and 3 are of importance with regard to commissioning. Chapters 4, 5 and 6 refer to the operation of the inverter with the KEYPAD operating device and provide information on the individual parameters.

**To meet client requirements for frequency inverters, there are a number of different versions with special functions. Version information which differs from standard is noted in the option descriptions.**

For the sake of clarity, the following symbols are used to identify warnings and important advice.



⇒ Caution: Danger of death by electrocution.



⇒ Caution: It is essential that you follow these instructions.



⇒ Caution: Disconnect device from mains and wait 2 minutes to allow the DC link capacitors to discharge.



⇒ Prohibited: Incorrect operation may cause damage to equipment.



⇒ Useful information, tip.

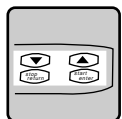

⇒ Setting with the KEYPAD is alterable.

# Signposts to Success

|          |  |            |
|----------|--|------------|
| <b>A</b> | <b>Useful information on the Operation Manual</b> .....                      | <b>A-2</b> |
| A.1      | Safety instructions .....  | A-5        |
| A.2      | Intended use .....   | A-5        |
| A.3      | Model and accessories .....  | A-7        |
| A.4      | Manufacturer's declaration for frequency inverters .....                     | A-8        |
| A.5      | VF1000 S series with CE official acceptance .....                            | A-12       |
| A.6      | Information concerning installation in accordance with EMC regulations ..... | A-16       |
| <b>1</b> | <b>Technical data</b> .....  | <b>1-1</b> |
| 1.1      | Design and layout .....  | 1-1        |
| 1.2      | Data table .....   | 1-2        |
| 1.3      | Cooling .....  | 1-4        |
| 1.4      | Dimensional diagrams .....   | 1-4        |
| 1.5      | Installation .....   | 1-7        |
| <b>2</b> | <b>Electrical connections</b> .....  | <b>2-1</b> |
| 2.1      | Connection plan .....  | 2-1        |
| 2.2      | Emitted interference/immunity to interference (EMC) .....                    | 2-4        |
| 2.3      | Power connections .....  | 2-5        |
| 2.3.1    | Mains connection .....   | 2-5        |
| 2.3.2    | Motor connection .....   | 2-6        |
| 2.3.3    | Length of motor cable .....  | 2-7        |
| 2.3.4    | PTC thermistor connection .....  | 2-7        |
| 2.3.5    | Braking chopper connection .....   | 2-8        |
| 2.4      | Control connections .....  | 2-9        |
| 2.4.1    | Specifications .....   | 2-9        |
| 2.4.2    | Function of the FSINA reference value input .....                            | 2-10       |
| 2.4.3    | Control functions using STR/STL .....  | 2-12       |
| 2.4.4    | Control function using S1IND/S2IND .....                                     | 2-13       |
| 2.4.5    | MOP function with S1IND/S2IND .....  | 2-15       |
| 2.4.6    | Signal outputs .....   | 2-19       |
| 2.4.7    | LustBus connection .....   | 2-21       |
| 2.4.8    | Frequency reference as PWM-signal (I1, I6, I7) .....                         | 2-23       |
| <b>3</b> | <b>Operation and fault diagnostics</b> .....                                 | <b>3-1</b> |

|          |   |            |
|----------|---|------------|
| <b>3</b> | <b>Operation and fault diagnostics .....</b>              | <b>3-1</b> |
| 3.1      | Operation indicators .....                                | 3-1        |
| 3.2      | Error messages .....                                      | 3-1        |
| 3.2.1    | Error messages with device response. ....                 | 3-1        |
| 3.2.2    | Warning messages .....                                    | 3-2        |
| 3.3      | Motor/inverter overload protection (I*t monitoring) ..... | 3-3        |
| <b>4</b> | <b>Using the KP100 KEYPAD .....</b>                       | <b>4-1</b> |
| 4.1      | Layout .....  | 4-1        |
| 4.2      | General .....   | 4-2        |
| 4.2.1    | Menu options .....  | 4-2        |
| 4.2.2    | Key functions .....                                       | 4-2        |
| 4.2.3    | LCD display .....   | 4-3        |
| 4.3      | Menu structure .....                                      | 4-4        |
| 4.3.1    | Overview .....  | 4-4        |
| 4.3.2    | MOP- function (motor operated potentiometer) .....        | 4-6        |
| <b>5</b> | <b>Parameter list.....</b>                                | <b>5-1</b> |
| 5.1      | Level 1 .....   | 5-1        |
| 5.2      | Level 2 .....   | 5-2        |
| 5.3      | Inverter-dependent and country-related parameters .....   | 5-4        |
| <b>6</b> | <b>Description of parameters .....</b>                    | <b>6-1</b> |
| 6.1      | Reference value selection .....                           | 6-1        |
| 6.2      | Actual values .....                                       | 6-5        |
| 6.3      | Frequencies .....   | 6-7        |
| 6.4      | Ramps .....   | 6-8        |
| 6.5      | Characteristics .....                                     | 6-9        |
| 6.6      | Special functions .....                                   | 6-11       |
| 6.7      | Signal outputs .....                                      | 6-16       |
| 6.8      | Program functions .....                                   | 6-17       |

## A.1 Safety instructions



While in operation, inverter surfaces can be conductive, uninsulated, sometimes also moving or rotating, and hot – depending on the degree to which they are protected. This means that a frequency inverter drive can endanger human life.

To prevent serious physical injury or considerable material damage, only qualified persons familiar with electrical drive equipment may work on the equipment. Only those persons who are familiar with mounting, installing, putting into operation and operating inverters and have appropriate professional qualifications shall be regarded as being qualified. These persons must read the Instruction Manual carefully before installation and commissioning and follow the safety instructions.

In this connection, the standards IEC 364 and CENELEC HD 384 or DIN VDE 0100 and IEC Report 664 or VDE 0110 and national accident prevention regulations or VBG 4 must be observed.

Repairs to the equipment may only be carried out by the manufacturer or by a repair workshop approved by him. Unauthorised opening and unprofessional intervention could lead to physical injury or material damage.

## A.2 Intended use



Inverters are components that are intended for installation into electrical systems or machines.

When installed in machines, the inverter may not be commissioned (i.e. it may not be put to its intended use) until such time as it is established that the machine corresponds to the provisions of EC directive 89/392/EEC (directive on machines); EN 60204 is to be observed.

In addition to the directive on low potential 73/23/EEC, the harmonised standards of the series prEN 50178/DIN VDE 0160 in connection with EN 60439-1/DIN VDE 0660 Part 500 and EN 60146/DIN VDE 0558 are applied with regard to inverters.

The technical data and the information concerning conditions of connection can be taken from the type plate and the documentation, and are to be observed under all circumstances.



The inverter are to be protected against unauthorised stress. In particular, components may not be bent and/or insulation distances changed during transport and use.

Inverters contain electrostatically endangered components that can easily be damaged when incorrectly handled. Electrical components may not be mechanically damaged or destroyed.

When work is being carried out on live inverters, the applicable national accident-prevention regulations (e.g. VBG 4) are to be observed.

Electrical installation is to be carried out in accordance with the relevant regulations (e.g. lead cross section, fuses, earthed lead connection). Other details are contained in the documentation.

Electronic devices are not totally fail-safe. The user himself shall be responsible for securing the drive if the device breaks down.



**If the inverter is used for special applications (e.g. explosion-proof area), the required standards and regulations (e.g. EN 50014 and EN 50018) must be observed.**



## A.3 Model and accessories

### General

The standard VF1000S model is denoted by the type designation only. Versions other than the standard are denoted by the addition of model codes to the type designation.

Each model code has a particular meaning – see inverter models. Model codes are also used for inverters that are not in accordance with the list. These are not given here.

### Order or type designation:

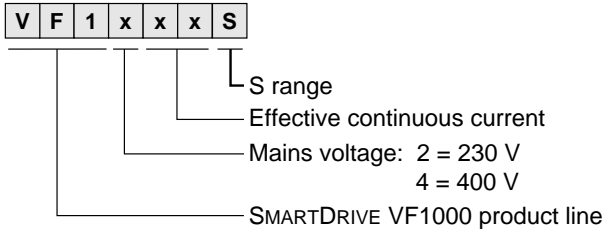

- Standard design:**
- Analog reference input, 2 digital control inputs
  - Varnished all-metal housing with plastic cover for KEYPAD KP100 mounting, protection IP20
  - Cold-plate design
  - Live automatic circuit-breaker thermostat and thermistor evaluation
  - Operation Manual in German

### Model codes when different to the standard



For each deviant version, a configuration location is defined that can only be assigned once. The number and sequence of codes to be added is open; they must be separated from each other with commas.

### Example:

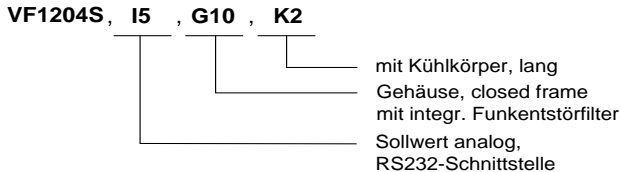

More precise details can be found in the “Data booklet VF1000”.

## A.4 Manufacturer's declaration for frequency inverters

D - 35633 Lahnau (Germany)

Tel.: 06441 / 966-0

Product Description: Frequency Inverter

Type: VF1104S; VF1202S; VF1204S;  
VF1402S

The product described is intended exclusively to be installed in another installation in the sense of the Machinery Directive.  
Commissioning is prohibited until such time as conformity of the end product to Directive 89/392/EEC is established.

The standards relevant to Directive 89/338/EEC (EMC) which have been applied to the product described are listed in the annex.  
In order to comply with EMC legislation the installation instructions and safety documentation must be observed.

Manufacturer: Company  
Lust Antriebstechnik GmbH

Place, Date: Lahnau, 30.11.1995

Legally binding signature:

  
K.H. Lust Managing Director

The annex forms part of this declaration.  
This declaration does not imply any assured characteristics.  
The installation directions and safety instructions in the product documentation must be observed.

MDEMC\_S1.DOC 30.11.95

Harmonized European Standards to EMC:

| Title  | Reference Number |
|--|------------------|
| Generic Standard: <b>Interference emission</b> | EN 50081-1       |
| Part 1: <b>Domestic</b>                        |                  |
| Generic Standard: <b>Interference immunity</b> | EN 50082-2       |
| Part 2: <b>Industrial</b>                      |                  |

National Standards:

| Reference Number | Date of Issue | Reference Number |
|------------------|---------------|------------------|
| .....            | .....         | .....            |
| .....            | .....         | .....            |
| .....            | .....         | .....            |
| .....            | .....         | .....            |
| .....            | .....         | .....            |

IEC - Standards :

| Reference Number | Date of Issue | Reference Number |
|------------------|---------------|------------------|
| .....            | .....         | .....            |
| .....            | .....         | .....            |
| .....            | .....         | .....            |
| .....            | .....         | .....            |
| .....            | .....         | .....            |

D - 35633 Lahnau (Germany)

Tel.: 06441 / 966-0

Product Description: Frequency Inverter

Type: VF1104S,G10;  
VF1202S,G10; VF1204S,G10

The product described is intended exclusively to be installed in another installation in the sense of the Machinery Directive. Commissioning is prohibited until such time as conformity of the end prx 89/392/EEC is established.

The standards relevant to Directive 89/338/EEC (EMC) which have bee product described are listed in the annexe. In order to comply with EMC legislation the installation instructions desc documentation must be observed.

Manufacturer: Company  
Lust Antriebstechnik GmbH

Place, Date: Lahnau, 30.11.1995

Legally binding signature:

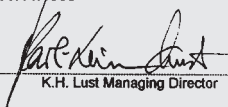
  
K.H. Lust Managing Director

The annexe forms part of this declaration.  
This declaration does not imply any assured characteristics.  
The installation directions and safety instructions in the product documentation must be

MDEMC\_S2.DOC 30.11.95

Harmonized European Standards to EMC:

| Title  | Reference Number |
|--|------------------|
| Generic Standard: <b>Interference emission</b> | EN 50081-1       |
| Part 1: <b>Domestic</b>                        |                  |
| Generic Standard: <b>Interference immunity</b> | EN 50082-2       |
| Part 2: <b>Industrial</b>                      |                  |

National Standards:

| Reference Number | Date of Issue | Reference Number |
|------------------|---------------|------------------|
|                  |               |                  |
|                  |               |                  |
|                  |               |                  |
|                  |               |                  |
|                  |               |                  |

IEC - Standards :

| Reference Number | Date of Issue | Reference Number |
|------------------|---------------|------------------|
|                  |               |                  |
|                  |               |                  |
|                  |               |                  |
|                  |               |                  |
|                  |               |                  |

## A.5 VF1000 S series with CE official acceptance

Copy of the CE test certificate for the VF1104S...VF1204S devices

|  |  |
|--|--|
| <b>Hersteller</b><br>Manufacturer                          | Fa. Lust<br>Antriebstechnik GmbH<br>Gewerbestr. 5-9<br>D-35631 Lahnu |
| <b>Typ</b><br>Item   | VF 1204  |
| <b>Auftraggeber</b><br>Customer                            | Fa. Lust<br>Antriebstechnik GmbH                                     |
| <b>Auftragsnummer</b><br>Order No.                         | 1 HID 3943   |
| <b>Anzahl der Seiten des Prüfberichts</b><br>Report volume | 35   |
| <b>Datum der Anlieferung</b><br>Date of delivery           | 30.08.95   |
| <b>Datum der Prüfung</b><br>Date of test                   | 05.09.95 - 16.11.95  |

Dieser Prüfbericht darf nur vollständig und unverändert weitergegeben werden. Ausz  
Prüfzentrum für Umweltsimulation und Typprüfungen (ZSP). Prüfberichte ohne Untersc  
gültigkeit. Die Prüfergebnisse beziehen sich ausschließlich auf den oben genannten Prüf  
This test report may only be reproduced in full length. Extracts publishing needs permis  
result without signature and seal are not valid. The test results relating only the test

Stempel

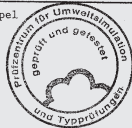

Leiter der Prüfstelle

(K.Pättschke)

QEZ0004

(generics standards), diese ermöglichen die es keine produktspezifischen EMV-Normen Die in der nachfolgenden Tabelle aufgeföh Konformitätstests gemäß dem EMV-Gesetz, Betriebsmittel die für eine Verwendung im t sowie im rauhen Industriebereich vorgehe Die Bewertung der Störfestigkeitsprüfungen Bewertungskriterien der EN 50082-2/03.95 (G

**Tabelle Prüfergebnisse:**

| Titel  | EG-Richtl.<br>Europäische Norm |
|--|--------------------------------|
| Niederspannungsrichtlinie<br>(SEB = Sicherheit elektrischer Betriebsmittel)              | 73/23/EWG                      |
| EMV-Richtlinie bzw. EMVG<br>Fachgrundnorm <b>Störfestigkeit</b> Teil 2: Industriebereich | 89/336/EWG<br>EN 50 082-2      |
| EMV-Richtlinie bzw. EMVG<br>Fachgrundnorm <b>Störaussendung</b> Teil 1: Wohngebiete      | 89/336/EWG<br>EN 50 081-1      |

**Bemerkungen zu den SEB-Prüfergebnissen:**

Bei den sicherheitsrelevanten Prüfungen gal dungen. Zusätzlich zur prEN 50178:1994 wurde herangezogen.

**Bemerkungen zu den EMV-Prüfergebnissen:**

Der Prüfling erwies sich als ausreichend stö der Störaussendung die Grenzwerte der Klass

| Ausgabe  | Name           | Datum    |
|----------|----------------|----------|
| 08.12.95 | QST/ H. Schupp | 937-24.T |

Copy of the CE test certificate for the  
VF1104S, G10...VF1204S, G10 devices

Object

Hersteller  
Manufacturer

Typ  
Item

Auftraggeber  
Customer

Auftragsnummer  
Order No.

Anzahl der Seiten des  
Prüfberichts  
Report volume

Datum der Anlieferung  
Date of delivery

Datum der Prüfung  
Date of test

Fa. Lust  
Antriebstechnik GmbH  
Gewerbestr. 5-9  
D-35631 Lahnau

VF 1204 G10

Fa. Lust  
Antriebstechnik GmbH

1 HID 3943

41

30.08.95

05.09.95 - 16.11.95

Dieser Prüfbericht darf nur vollständig und unverändert weitergegeben werden. Auszug  
Prüfzentrums für Umweltsimulation und Typprüfungen (GST). Prüfberichte ohne Unterschrift  
gültigkeit. Die Prüfergebnisse beziehen sich ausschließlich auf den oben genannten Prüf-  
This test report may only be reproduced in full length. Extracts publishing needs permission  
result without signature and seal are not valid. The test results relating only the test

Stempel



Leiter der Prüfstelle

*K. Pätzschke*

(K.Pätzschke)

QEZ0004



(generics standards), diese ermöglichen die es keine produktspezifischen EMV-Normen Die in der nachfolgenden Tabelle aufgeführt Konformitätstests gemäß dem EMV-Gesetz, Betriebsmittel die für eine Verwendung im ty sowie im rauen Industriebereich vorgesehen Die Bewertung der Störfestigkeitsprüfungen Bewertungskriterien der EN 50082-2/03.95 (Ge

**Tabelle Prüfergebnisse:**

| Titel  | EG-Richtl.<br>Europäische Norm |
|--|--------------------------------|
| Niederspannungsrichtlinie<br>(SEB=Sicherheit elektrischer Betriebsmittel)                | 73/23/EWG                      |
| EMV-Richtlinie bzw. EMVG<br>Fachgrundnorm <b>Störfestigkeit</b> Teil 2: Industriebereich | 89/336/EWG<br>EN 50 082-2      |
| EMV-Richtlinie bzw. EMVG<br>Fachgrundnorm <b>Störaussendung</b> Teil 1: Wohngebiete      | 89/336/EWG<br>EN 50 081-1      |

**Bemerkungen zu den SEB-Prüfergebnissen:**

Bei den sicherheitsrelevanten Prüfungen gab dungen. Zusätzlich zur prEN 50178:1994 wurde herangezogen.

**Bemerkungen zu den EMV-Prüfergebnissen:**

Der Prüfling erwies sich als ausreichend störi der Störaussendung die Grenzwerte der Klasse

|          |                |           |
|----------|----------------|-----------|
| Ausgabe  | Name           | Datum     |
| 08.12.95 | QST/ H. Schupp | 946-24.TY |

## A.6 Information concerning installation in accordance with EMC regulations

EMC means:

The VF1000S inverter range has been developed in such a way that both the directive on low voltage and, when the appropriate measures are taken, the EMC directive – even the strict directive applicable for residential areas – can be adhered to. Acceptance tests on the device were carried out under laboratory conditions at the accredited Schenk test centre and official acceptance is not bindingly transferrable to the installed machine or system.

To optimise installation, instructions for installation are given in the diagram below.

Installation in line with EMC principles is achieved ...

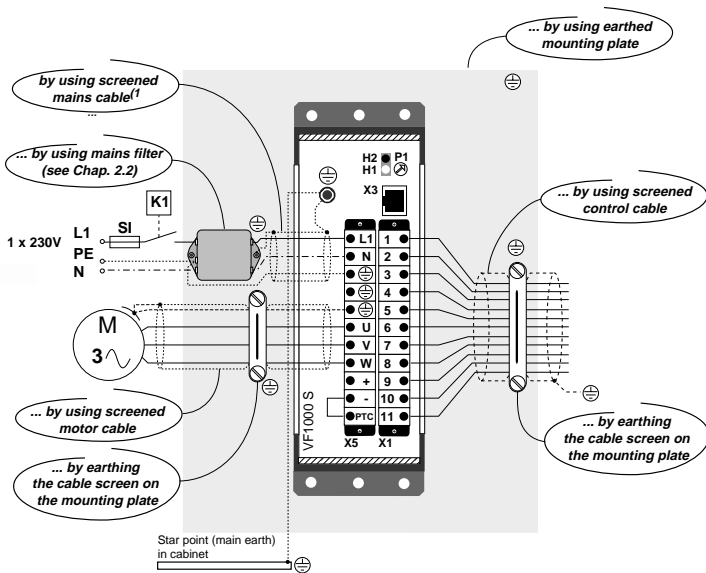

<sup>(1)</sup>when lead lengths of > 0.3m are used



### Important:

For further information, see Chap. 2.1 and 2.2

# 1 Technical data

## 1.1 Design and layout

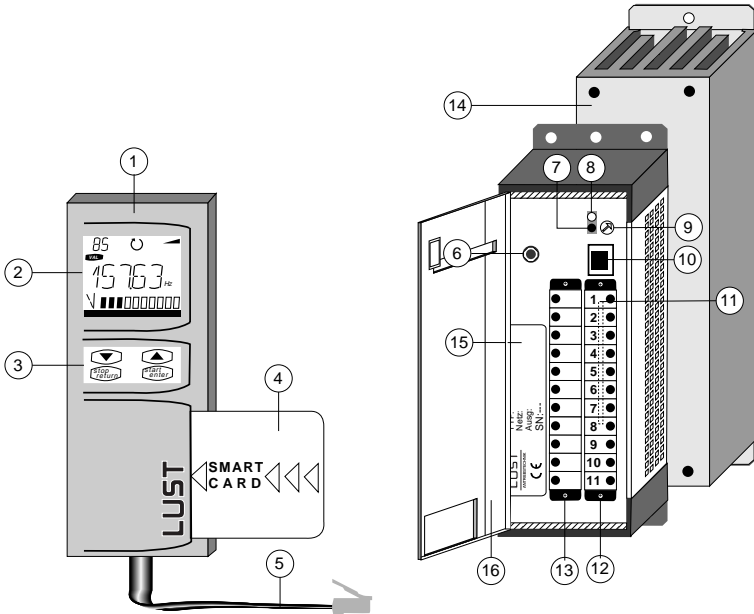

### Key

- |                                       |   |
|---------------------------------------|---|
| ① KeYPAD operating device*            | ⑨ Potentiometer P1, programmable                      |
| ② LCD display field with 140 segments | ⑩ KeYPAD socket                                       |
| ③ Membrane KeYPAD                     | ⑪ X2 jumper strip, concealed behind X1 terminal strip |
| ④ SMARTCARD* chip card                | ⑫ X1 terminal strip, control connections              |
| ⑤ KeYPAD connecting cable*            | ⑬ X5 terminal strip, power connections                |
| ⑥ Connection screw $\oplus$           | ⑭ Heat sink **  |
| ⑦ LED H1 (red) error indicator        | ⑮ Type plate  |
| ⑧ LED H2 (green) operating indicator  | ⑯ Cover   |

\* Accessories, \*\* Designs, see data booklet VF1000

## 1.2 Data table

|   | Code               | Dim.            | VF1104S                                     | VF1202S             | VF1204S           | VF1402S             |
|---|--------------------|-----------------|---|---------------------|-------------------|---------------------|
| <b>Motor output</b>                           |                    |                 |   |                     |                   |                     |
| Recommended rating with 4-pole standard motor | P                  | W               | 375   | 375                 | 750               | 750                 |
| Power   | S                  | VA              | 670 <sup>1</sup>                            | 840 <sup>2</sup>    | 1400 <sup>2</sup> | 1450 <sup>3</sup>   |
| Phase current (100%)                          | I <sub>N</sub>     | A               | 3.2 <sup>1</sup>                            | 1.9 <sup>2</sup>    | 3.2 <sup>2</sup>  | 1.9 <sup>3</sup>    |
| Continuous load                               | -                  | %               | 110   |                     |                   |                     |
| Overload factor (for 60s)                     | 1.5xI <sub>N</sub> | A               | 4.8   | 2.9                 | 4.8               | 2.9                 |
| Voltage                                       | U                  | V               | 3 x 0...110                                 | 3 x 0...230         |                   | 3 x 0...400         |
| Rotating field frequency                      | f                  | Hz              | 0 ... 400                                   |                     |                   |                     |
| Frequency resolution                          | f                  | %               | 0.1 of F <sub>MAX</sub> (0.05 Hz min.)      |                     |                   |                     |
| Load type                                     | -                  | -               | ohmic/inductive                             |                     |                   |                     |
| Cable length (motor)                          | L                  | m               | 50 max.*                                    |                     |                   | 10 max.*            |
| Short circuit proof                           | -                  | -               | at the terminals                            |                     |                   |                     |
| Leak to earth                                 | -                  | -               | test after every power on                   |                     |                   |                     |
| <b>Mains input</b>                            |                    |                 |   |                     |                   |                     |
| Mains voltage                                 | U                  | V               | 1 x 110<br>+30/-20%                         | 1 x 230<br>+15/-20% |                   | 3 x 460<br>+10/-30% |
| Recc. mains protection <sup>4</sup>           | I                  | AT              | 1 x 10                                      |                     |                   | 3 x 10              |
| Mains frequency                               | f                  | Hz              | 50/60 +/-10%                                |                     |                   |                     |
| Cross section for connection                  | A                  | mm <sup>2</sup> | 1.5   |                     |                   |                     |
| <b>General</b>                                |                    |                 |   |                     |                   |                     |
| Operation                                     | -                  | -               | 2 quadrants with braking chopper (ext.) 4 Q |                     |                   |                     |
| Power loss                                    | P <sub>v</sub>     | W               | 30  | 25                  | 35                | 45                  |
| Efficiency (at P <sub>N</sub> )               | h                  | %               | 95  | 96                  | 95                | 94                  |
| <b>Ambient conditions</b>                     |                    |                 |   |                     |                   |                     |
| Cooling air temperature                       | T                  | °C              | 0 ... 40                                    |                     |                   |                     |
| Temperature-dependent reduction in power      | -                  | -               | 2.5%/°C in the range 40 ... 50 °C           |                     |                   |                     |
| Installation height a. s. l.                  | H                  | m               | 1000 max., other specifications on request  |                     |                   |                     |
| Relative humidity                             | -                  | %               | 15 ... 85 non-condensing                    |                     |                   |                     |
| Vibration                                     | -                  | -               | 2 g (IEC 68-2-6)                            |                     |                   |                     |
| <b>Weight/dimensions</b>                      |                    |                 |   |                     |                   |                     |
| Dimensions                                    | WxHxD              | mm              | 65 x160 x133 (without lugs)                 |                     |                   |                     |
| Weight excl. packaging                        | -                  | kg              | approx. 0.9                                 |                     |                   |                     |
| Protection                                    | -                  | -               | IP20, VBG4, NEMA 1                          |                     |                   |                     |
| Type of installation                          | -                  | -               | vertical wall mounting                      |                     |                   |                     |

<sup>1</sup>for 110V mains voltage

<sup>2</sup>for 230 V mains voltage

<sup>3</sup>for 400 V mains voltage

<sup>4</sup>When securing the network, factor influencing the local network are also to be taken into account.

\*When a longer motor cable is used, a motor choke must be installed (see Chap. 2.3.3)

Deviations from the power table in the case of the G10 model:

| <b>G10 model</b>                           | <b>Code</b> | <b>Dim.</b> | <b>VF1202S</b> | <b>VF1204S</b> | <b>VF1402S*</b> |
|--|-------------|-------------|----------------|----------------|-----------------|
| Phase current                              | $I_N$       | A           | 1.9            | 3.2            | 1.9             |
| Recc. rating with<br>4-pole standard motor | $P_N$       | W           | 375            | 750            | 750             |
| Limit curve see EN55011                    | FA          | –           | Class A        | Class A        | Class A         |
| Limit curve see EN55011                    | FB          | –           | Class B        | Class B**      | –               |

\* Code FB is not possible

\*\* Not possible in connection with Code C8

### 1.3 Cooling

The S range SMARTDRIVE frequency inverters are designed for assembly on a mounting plate that conducts well. The following table shows the area required.

| Characteristic | Area                  | Material               | Clock frequency |
|----------------|-----------------------|------------------------|-----------------|
| ————           | > 0.25 m <sup>2</sup> | Aluminium, not painted | 7.8 kHz         |
| — — —          | > 0.25 m <sup>2</sup> | Painted steel          | 7.8 kHz         |

The diagram on the right shows the inverter loading  $I/I_N$  relative to the ambient temperature  $T_U$  and the mounting plate used. See also equipment installation.

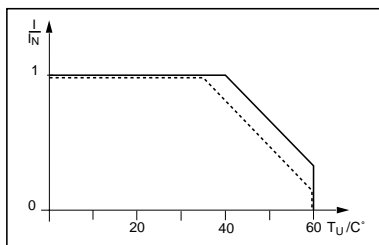

Parameter 74-PWM can be used for programming various clock frequencies for the switching processes in the final stage of the equipment. The higher the clock frequency, the higher the losses. Consequently, higher clock frequencies are only possible at the cost of a reduction in performance. Contact us for further details.

### 1.4 Dimensional diagrams

Standard model

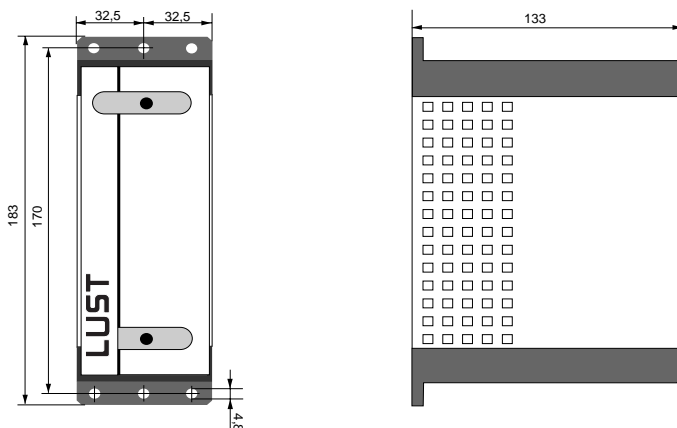

all dimensions in mm

Standard model with accessories  
(Heat sink + KEYPAD)

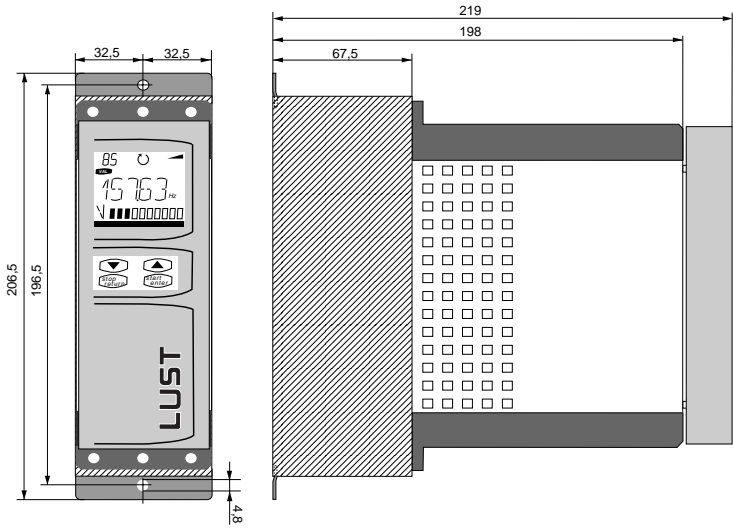

all dimensions in mm

G10 model

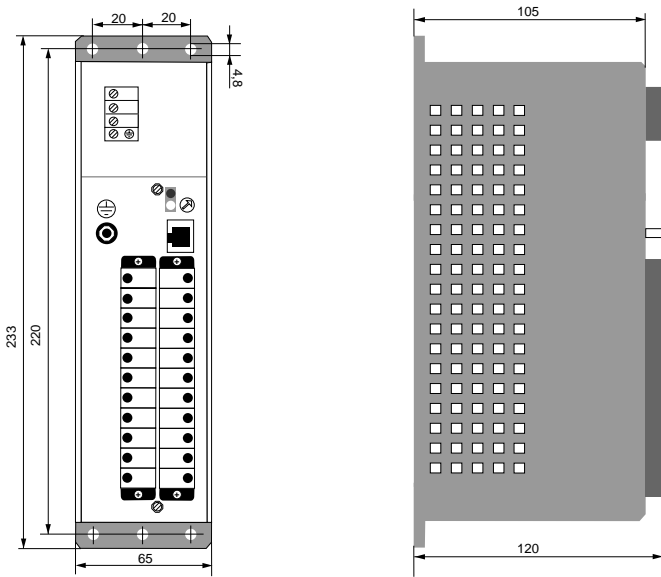

all dimensions in mm

G10 model with accessories (heat sink, terminal cover)

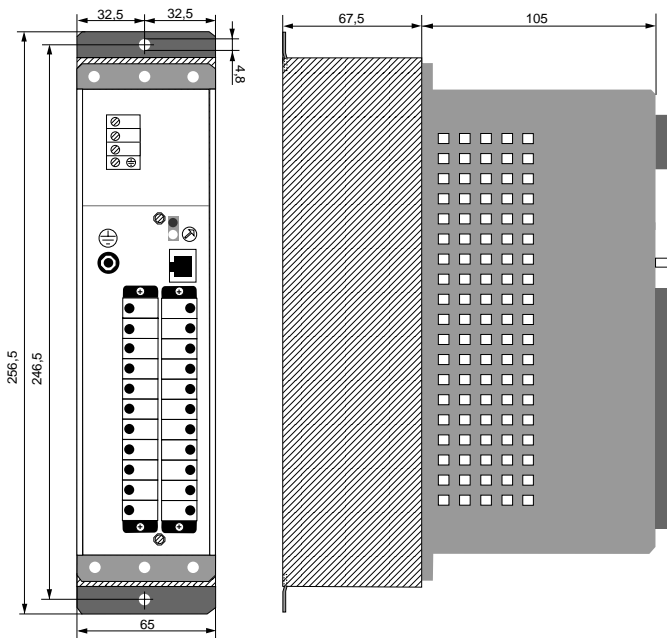

G8 model (closed frame)

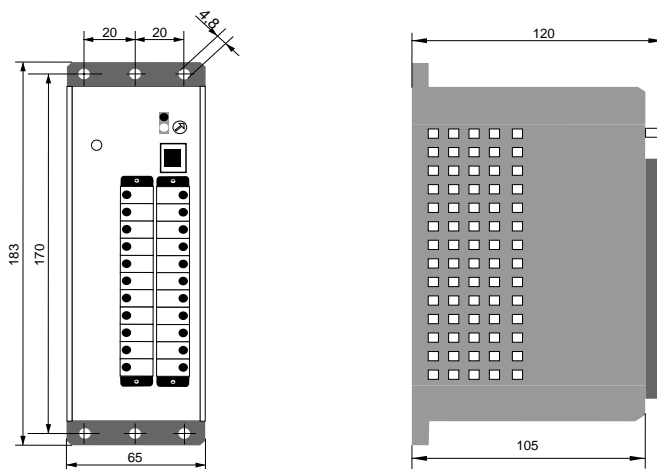

all dimensions in mm



## 1.5 Installation

### General:

The location for installation must be free from conducting or corrosive materials and also free from humidity. Frequency inverters are normally housed in cabinets with external air throughflow. They are attached to a mounting board with four M4 screws.

It is essential that the minimum distances above and below the unit are observed to avoid heat build-up. The air openings on the top surface must not be covered or closed under any circumstances.



### Warning:

Ensure that no foreign bodies, such as metal swarf or screws, drop into the inverter during installation, as it may be damaged beyond repair.

If a heat sink is used (order no. A026.V01.0), the technical specifications are achieved without a special mounting plate. The inverters may then also be mounted side by side (see diagram).



A = 100 mm

B = 30 mm

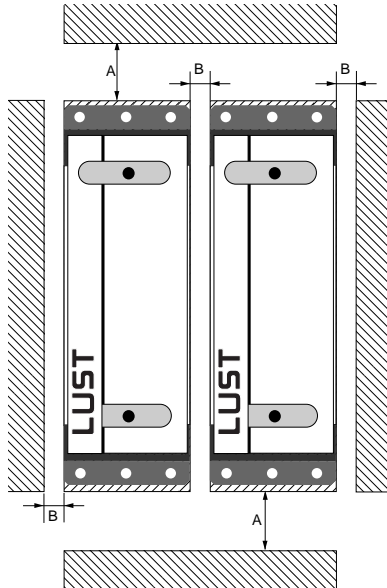

## 2 Electrical connections

### 2.1 Connection plan

VF1104S mains connection = 1 x 110 VAC

VF1202S/1204S mains connection = 1 x 230 VAC

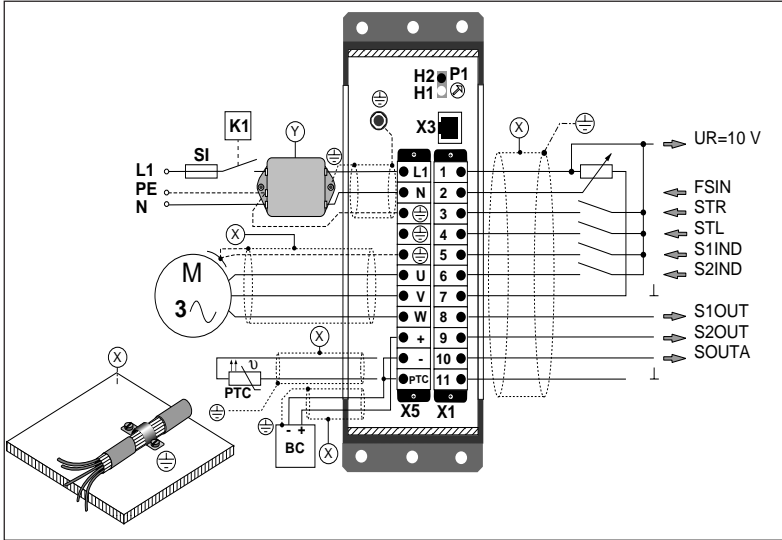

VF1402S mains connection = 3 x 400/460VAC

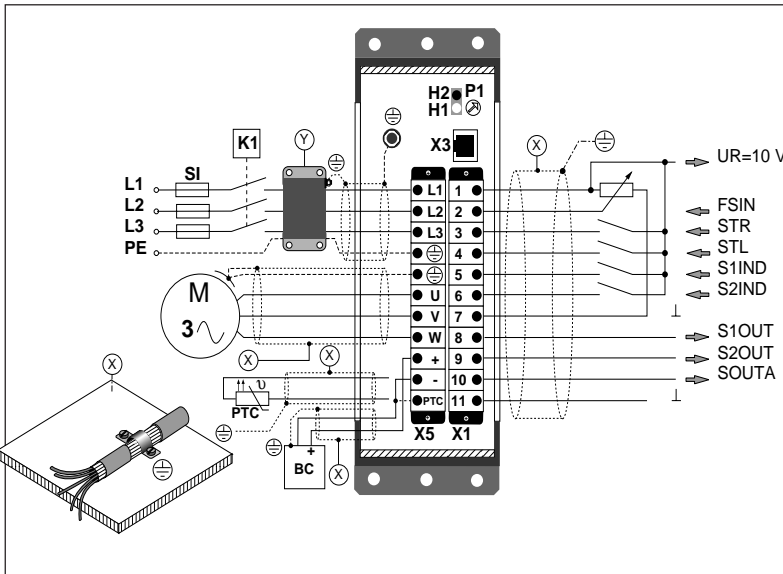

VF1104S,G10  
VF1202S/1204S,G10

Mains = 1 x 110 VAC  
Mains = 1 x 230 VAC

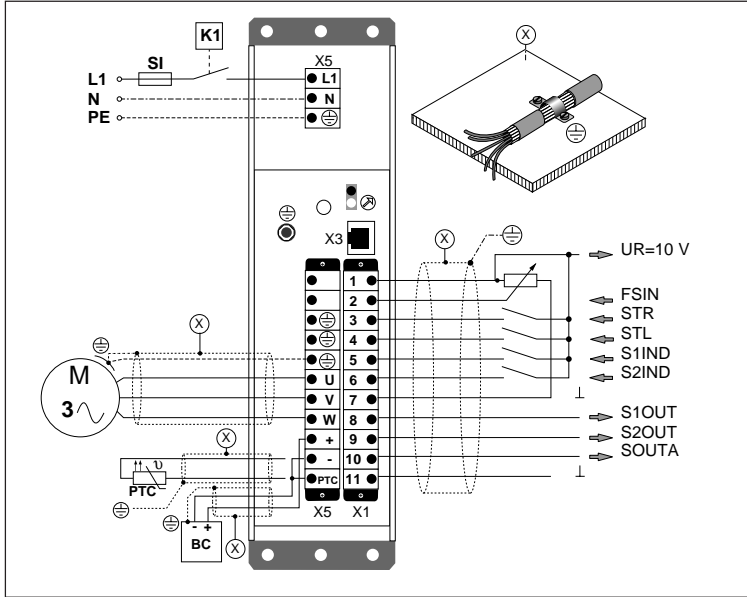

VF1402S,G10\*

Mains = 3 x 400/460VAC

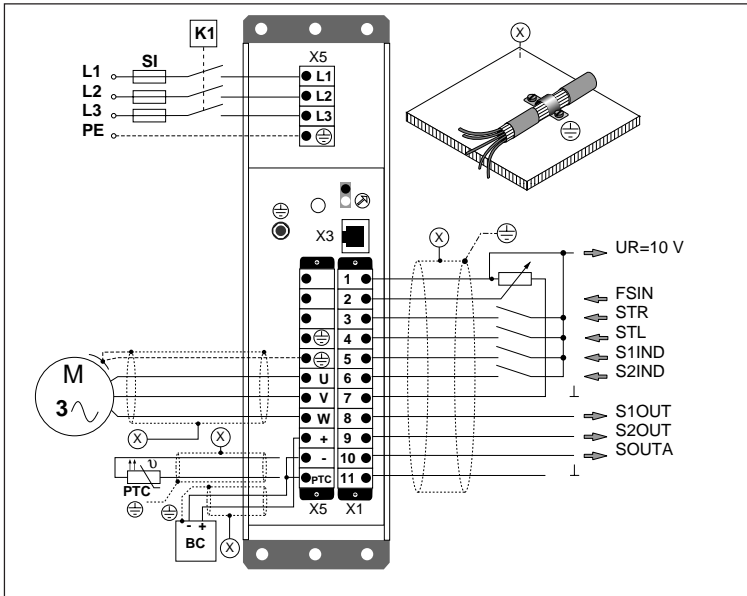

\* Device to order

**Key to terminals:**

| <b>X1</b>     | <b>Code</b> | <b>Description</b>   |
|---------------|-------------|--|
| 1             | UR          | 10 V ref. voltage for ref. value potentiometer                     |
| 2             | FSIN        | Frequency reference value input                                    |
| 3             | STR         | Start clockwise input  |
| 4             | STL         | Start anti-clockwise input   |
| 5             | S1IND       | Programmable input, digital  |
| 6             | S2IND       | Programmable input, digital  |
| 7, 11         | Masse       | Reference point, control connection                                |
| 8             | S1OUT       | Programmable output LOW active                                     |
| 9             | S2OUT       | Programmable output LOW active                                     |
| 10            | SOUTA       | Programmable output analog   |
| <b>X5</b>     |             | <b>Description</b>   |
| L1,N, ⊕       |             | Power connection, single phase (110 or 230 V)                      |
| L1, L2, L3, ⊕ |             | Power connection, three phase (400 or 460 V)                       |
| (+) , (-)     |             | For external brake chopper or DC voltage supply                    |
| (-) , PTC     |             | Connection for motor thermistor<br><b>(note: at mains voltage)</b> |
| ⊕             |             | Connection for star point (main earth) in cabinet                  |
| X             |             | Example of connection for EMC ground clamps for easy               |
| Y             |             | Example of connection for ext. mains filter                        |
| K1            |             | Example of connection for mains protection                         |

## 2.2 Emitted interference/immunity to interference (EMC)

All S range SMARTDRIVE frequency inverters fulfil EMC requirements with regard to immunity to interference in industrial areas in accordance with EC directives/European norms 89/336/EWG, prEN 50 062-2 (see also the EMC test certificate in Section A).

The certified EMC test on the immunity to interference of the inverters was carried out under laboratory conditions in accordance with prEN 50082-2/01.93.



**To observe EMC legislation when installing the inverter in e.g. a machine, the following instructions must be observed:**

- ⇒ The motor lead, the mains lead and the control leads are to be laid separately and screened from one another.
- ⇒ The device is to be screwed onto a well-earthed mounting plate. A toothed washer (Z) is to be placed under each of the 4 fastening screws to ensure that the inverter casing is in proper contact with the mounting plate.
- ⇒ The connection of the mains lead screening on the inverter side is made by means of as short a lead as possible (length < 2.5 cm) to the earthing screw (see connection plan).
- ⇒ The screen connection of the motor and control leads must be made on a plane with the conductive mounting plate (remove paint if necessary) as close to the inverter terminals as possible. This is to be carried out with a conductive cable clip in accordance with diagram (X).
- ⇒ The screening of the external PTCs must also be made on a plane with the conductive mounting plate.

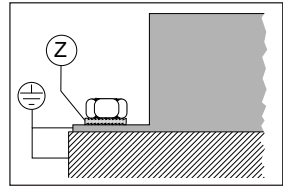

**Warning: The PTC input is at mains voltage.**

- ⇒ The terminal box of the motor must be RF-shielded. It must therefore be made of metal or metal-coated plastic.
- ⇒ The cable bushing of the motor lead at the terminal box is to be made using a conductive cable gland with screen connection.

To avoid conducted, asymmetrical interference voltage, a mains filter in accordance with diagram (Y) is to be used.

For further information see "Data booklet VF1000".

## 2.3 Power connections

### 2.3.1 Mains connection

#### General

Inverters must be connected to the mains power supply in accordance with the VDE regulations such that they can be isolated from the mains at any time using appropriate means of isolation such as a master switch. See also connection plan.



#### Note:

The inverter may only be switched on to the mains every 60 seconds. Pulsing the mains contactor (K1 on P. 2.1 and 2.2) is not permitted.



Due to the generally high leakage current (> 3.5 mA), the use of F1 protective switches alone is not permitted. A protective earth is therefore mandatory.

Mains fuses must be designed to suit the current load of the connecting cable to DIN 57100 standard (see recommendations in the power table).



#### VF1104S connection

The mains connection (1 x 110 VAC) to terminals X5/ L1, N,  $\ominus$ .  
For technical specifications, see the data table.

#### Warning!

Never connect 230/400/460 VAC to terminals X5/L1 and X5/N. The high voltage would destroy the equipment.



#### VF1202S and VF1204S connections

The mains connection (1 x 230 VAC) is made at terminals X5/ L1, N,  $\ominus$ .  
For technical specifications, see the data table.

#### Warning!

Never connect 400/460 VAC to the terminals X5/L1 and X5/N. The excessive voltage would destroy the equipment.



#### VF1402S connection

The mains connection (3 x 400 VAC) is made at terminals X5/ L1, L2, L3,  $\ominus$ . For technical specifications, see the data table.

## 2.3.2 Motor connection

### General

Standard three-phase motors in the range up to 4 kW are available according to IEC 34 for various mains supplies in Delta (3 x 230 V) and in Star (3 x 400 V) formats.

Three-phase standard motors for 110 V three-phase mains supply are generally required in non-European countries (e.G. U.S.a.). Information on connection should be obtained from the manufacturers of the motor.

**When using three-phase special motors that do not correspond to IEC 34, information concerning the type of connection is to be sought from the manufacturer of the motor.**

For EMC installation, the terminal box of the motor must be RF-shielded. It must therefore be made of metal or metal-coated plastic.

The cable bushing of the motor lead at the terminal box is to be made with a conductive cable gland with screen connection.

### VF1104S connection



The motor connection is made at terminals X5/  $\oplus$ , U, V, W. The connections to the motor must be 3 x 110 V in accordance with the manufacturer's specifications.



### VF1202S and VF1204S connection

The motor connection is made at terminals X5/  $\oplus$ , U, V, W. The motor connection must be in Delta format (3 x 230 V).

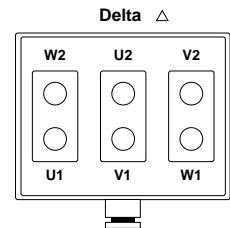

### VF1402S connection

The motor connection is made at terminals X5/  $\oplus$ , U, V, W. The motor connection must be in Star format (3 x 400 V).

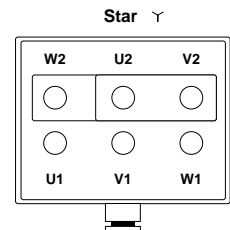

### 2.3.3 Length of motor cable

The motor cable may be no longer than the length given in the Power table, as longer leads with higher conduction capacities (especially screened leads) are at mains voltage. Higher lead capacities give rise to a high leakage current that switches off the inverter.

When installation makes greater lead lengths necessary, a corresponding motor throttle is to be provided (see also connection plan in Chap. 2.1).

| Inverter | Choke type                      | Length | Order no. |
|----------|---------------------------------|--------|-----------|
| VF1104S  | Three-phase current motor choke | > 50 m | to order  |
| VF1202S  | Three-phase current motor choke | > 50 m | to order  |
| VF1204S  | Three-phase current motor choke | > 50 m | to order  |
| VF1402S  | Three-phase current motor choke | > 10 m | 0.782.ZAD |

### 2.3.4 PTC thermistor connection

A thermistor (PTC) can be connected at terminals X5/ – and PTC for thermal monitoring of the motor. If no thermistor is used, both terminals must be bridged.

**Warning:**

The thermistor connections are at mains voltage. Before connecting the thermistor, the inverter must be disconnected from the mains.

**Switching point:**

The resistance of the thermistor used must be > 3kΩ at the rated response temperature (cf. DIN 44081).

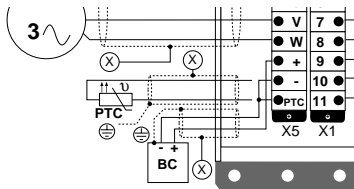



## 2.3.5 Braking chopper connection

### General

If the rotor rpm is higher than the corresponding stator rpm, the motor returns energy to the inverter. In this mode, the motor is braked via the inverter.

For reliable braking, an external braking chopper has also to be used, depending on the energy levels involved. This converts the regenerative braking energy into heat in load resistors.

The braking chopper is directly connected to the DC intermediate circuit / (ZK) of the inverter. It switches on automatically when the ZK voltage increases through regenerative energy.



### Warning:

There is a direct relationship between the switching point of the braking chopper and the mains voltage of the inverter. Consequently, only the following device combinations are permitted.

| Braking chopper type | => | inverter type    |
|----------------------|----|------------------|
| to order             | => | VF1104S          |
| BC1300               | => | VF1202S/ VF1204S |
| BC1400               | => | VF1402S          |

The temperature switch must not be connected to safety low-voltage.

### Example of connection:

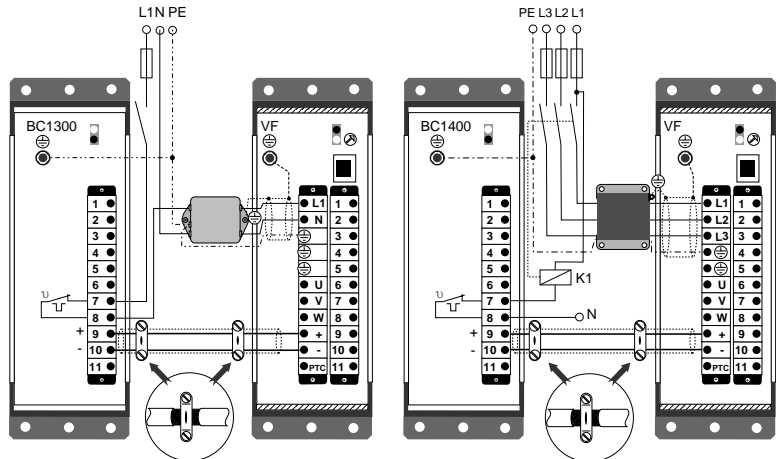

For safety reasons, it is essential to read the relevant instruction manual when using a braking chopper.

## 2.4 Control connections

### 2.4.1 Specifications

| Connection                                    | Specification   |
|---|---|
| UR reference output                           | 10 V $\pm$ 2%<br>not short-circuit-proof<br>load capacity max. 15 mA  |
| FSIN frequency reference value input (analog) | cascading of several inverters via voltage reference value possible<br>resolution 10 BIT<br>linearity < 2%<br>voltage 0...10 V, $R_i = 100 \text{ k}\Omega$<br>current 0(4)...20 mA, $R_i = 500\Omega$<br>software filters up to 123 ms |
| Digital control inputs STR, STL, S1IND, S2IND | low < 3 V, high > 8 V (max. 30 V)<br>current (at 24 V) = 5 mA<br>SPS-compatible, +24 V-logic to ground<br>hardware filter 3.3 ms<br>software filter 1 x poling cycle (1...8.2 ms)   |
| Digital control outputs S1OUT, S2OUT          | open collector outputs active LOW,<br>switch to ground<br>current loading max. 50 mA<br>not short-circuit-proof   |
| SOUTA output, analog *                        | output signal 0...10 V<br>linearity < 2%, resolution 10 BIT<br>current loading max. 2 mA<br>not short-circuit-proof   |
| SOUTA output pulse or PWM signal*             | open collector output, $U_B = 15 \text{ V}$ max.<br>current loading max. 15 mA<br>not short-circuit-proof   |

\* The SOUTA output will only function with matching of the jumper strip X2/J3 and J4 and programming of paramter 61-SOUTA.

## 2.4.2 Function of the FSINA reference value input

### Setting FSINA analog frequency reference value

The rotating field frequency is set at the terminals X1/2 and 7. Using jumper strip X2, the input is matched to the appropriate drive type. There are three possibilities for doing this:

1. Connection of potentiometer  
(4.7... 10 k $\Omega$ )

X2 matching:  
position C

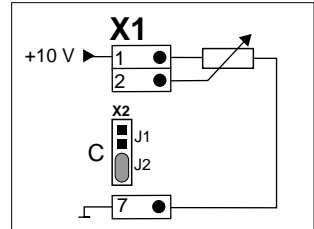

2. External voltage ref. value  
0(2)...10 V DC

X2 matching:  
position C: 0... 10 V  
position A: 2... 10 V

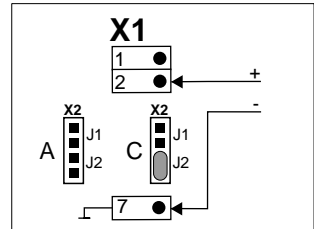

3. External current ref. value  
0(4)...20 mA

X2 matching:  
position D: 0... 20 mA  
position B: 4... 20 mA

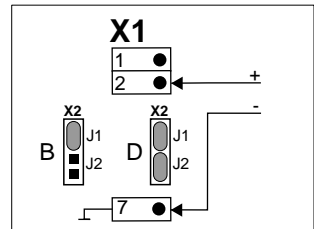

Position of X2 (jumper = plug-in jumper).  
The jumper strip X2 is accessible when the terminal strip X1 is removed.  
The position of the jumpers shown represents the factory setting.

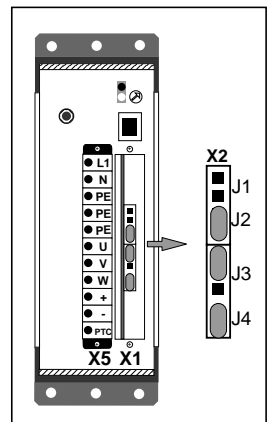

## Function table

Apart from matching the FSIN input using jumper strip X2, the device software provides matching opportunities using the KEYPAD or the interface. Parameter 04-FSSEL (frequency reference value selector) determines the origin of the frequency reference value and, with the details as set previously, must be **04-FSSEL = 4 (factory setting)**.

| Position | J1  | J2  | Function        | Comment                              |
|----------|-----|-----|-----------------|--------------------------------------|
| A        | ■ ■ | ■ ■ | input 2...10 V  | Deviation < 2 %                      |
| B        | ○   | ■ ■ | input 4...20 mA | $R_i = 500 \Omega$                   |
| C        | ■ ■ | ○   | input 0...10 V  | Deviation < 2 %<br>(factory setting) |
| D        | ○   | ○   | input 0...20 mA | $R_i = 500 \Omega$                   |

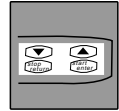

### Note:

With the prescribed start signal STL or STR, the inverter can also be started using the frequency reference value input.

FS > 0.5 Hz → START

FS < 0.25 Hz → STOP



### 2.4.3 Control functions using STR/STL



**Warning:**

For safety reasons, the inverter must not be switched on to the mains supply using the preset control function STL or STR. The inverter only recognizes the start function if it has been activated **after** power on or self test.

The choice of direction of rotation is made by inputs STR or STL using two switching contacts as shown on the connection plan. Alternatively, the choice of direction of rotation may also be made using two external voltage signals in accordance with the control connection specifications.

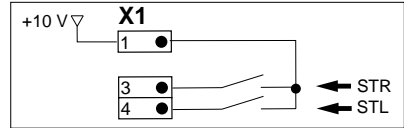

**START:** The inverter starts when both a control signal STRL or STR and a reference value for the three-phase frequency of at least 0.5 Hz = 0.1 V are present at FSIN.

**STOP:** The inverter stops when the control signals STL or STR have been discontinued. The motor which is connected coasts on uncontrolled without braking.

**BRAKE/STOP:** The inverter brakes the motor to STOP when two control signals are present at STL and STR. A fresh start occurs when one of the two control signals is set to zero.

**BRAKEWITH RSTOP:** When releasing the starting signals (STL and STR) the RSTOP ramp becomes active. The deceleration ramp is adjusted with parameter 36-RSTOP.

**REVERSING:** The direction of rotation is reversed when the control signal is changed from one control input (e.g. STL) to the other control input (e.g. STR). The overlap interval must be at least **8 ms**.

**Truth table**

| STL    | STR         | Explanation                          |
|--------|-------------|--------------------------------------|
| 0      | 0           | STOP, motor coasts                   |
| 1      | 0           | START, anti-clockwise with RACC/RDEC |
| 0      | 1           | START, clockwise with RACC/RDEC      |
| 1      | 1           | BRAKING, motor controlled to STOP    |
| 0<br>1 | 1<br>↓<br>0 | reverse direction of rotation        |

## 2.4.4 Control function using S1IND/S2IND

### Choice of fixed frequencies FF2, FF3, FF4

In addition to the FSINA input, the frequency reference value can also be preset using control inputs S1IND/S2IND as a fixed frequency. There is a choice of three fixed frequencies which can be activated in accordance with the truth table.

The following truth table relates to the factory setting, parameter **31-KSEL = 0** (data record selector).

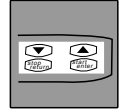

### Truth table

| S1IND | S2IND | Explanation                   | Range      | Factory setting |
|-------|-------|-------------------------------|------------|-----------------|
| 0     | 0     | FSINA input, active           | 0...999 Hz | FMAX = 50 Hz    |
| 1     | 0     | FF2-1 fixed frequency, active | 0...999 Hz | FF2-1 = 3 Hz    |
| 0     | 1     | FF3 fixed frequency, active   | 0...999 Hz | FF3 = 15 Hz     |
| 1     | 1     | FF4 fixed frequency, active   | 0...999 Hz | FF4 = 30 Hz     |

### Sequence diagram

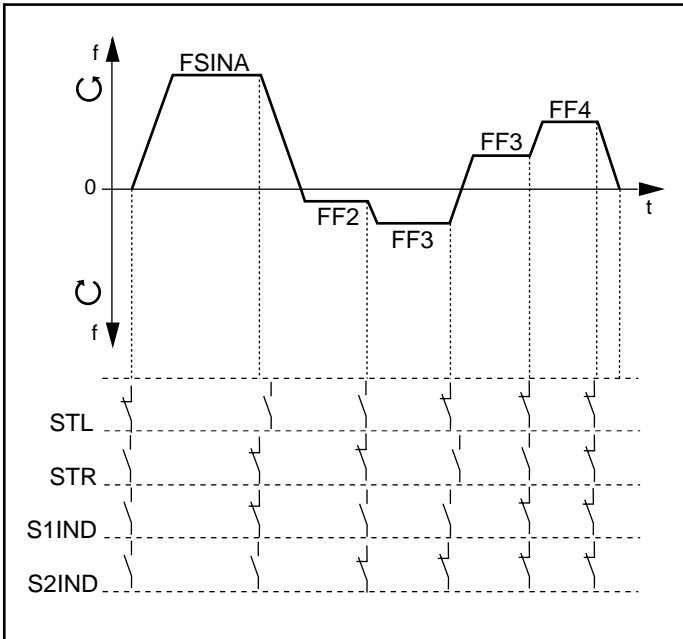

### Data record switching

The inverter has two data records which can be switched using the control inputs S1IND/S2IND. Each data record has a total of eight parameters which may be set individually (for further information, see "Description of parameters").

The following truth table relates to parameter **31-KSEL = 2** (data record selector).

#### Truth table



| S1IND | S2IND | Explanation               | Data record |
|-------|-------|---------------------------|-------------|
| 0     | 0     | FSINA input, active       | 1 active    |
| 1     | 0     | FF2-1 fixed freq., active | 1 active    |
| 0     | 1     | FSINA input, active       | 2 active    |
| 1     | 1     | FF2-2 fixed freq., active | 2 active    |

### Ramp switching

The data record switching facility means that the inverter also has 2 ramp pairs. The function of ramp switching is shown by the following sequence diagram. For further information, see "Description of parameters".

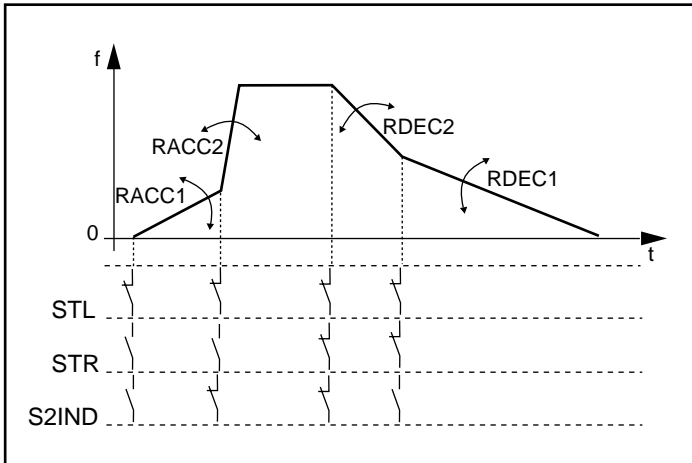

## 2.4.5 MOP function with S1IND/S2IND

### Definitions

- Base value    preset analog speed reference at FSIN input
- Offset        Ratio of elevation or lowering from base value, influenced by inputs S1IND and S2IND
- S1IND        Input of offset setting for reference increase
- S2IND        Input of offset setting for reference decrease
- Reference    Input, which is raised or lowered by the ratio of the offset (Base value +/- Offset)

| 04-FSSEL = >                                 | 17 | 18 | 19 | 20 | 21 | 22 |
|--|----|----|----|----|----|----|
| Reset offset with S1IND = 1, S2IND = 1       |    | x  |    | x  |    | x  |
| Reset offset with braking ramp RSTOP         |    |    |    |    | x  | x  |
| Retain offset when power off (EEPROM memory) |    |    | x  | x  |    |    |



### Explanation of diagrams in examples:

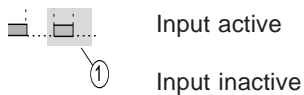

 RDEC1    Braking ramp with anti-clockwise rotation

 RDEC1    Braking ramp with clockwise rotation

 RACC1    Acceleration ramp with clockwise rotation

 RACC1    Acceleration ramp with anti-clockwise rotation

 RSTOP    Braking ramp, parameter 36-RSTOP



### Example: Basic function with reset to base value

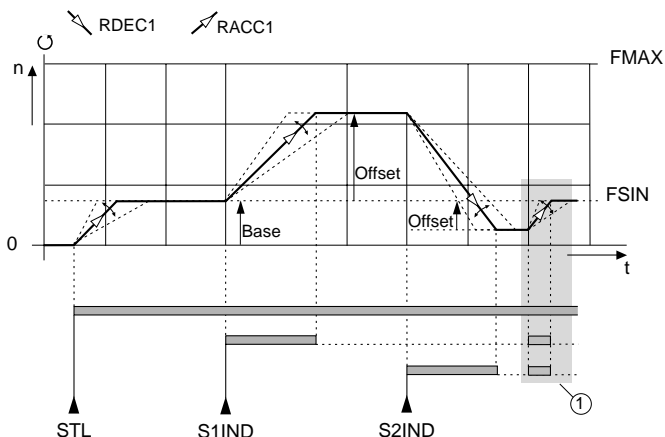

**Key:** ① Resetting of the reference to the base value (only possible with 04-FSSEL = 18/20/22).

### Example: Direction of rotation with STL and STR

The setting parameter applies 04-FSSEL = 17/18/19/20/21/22

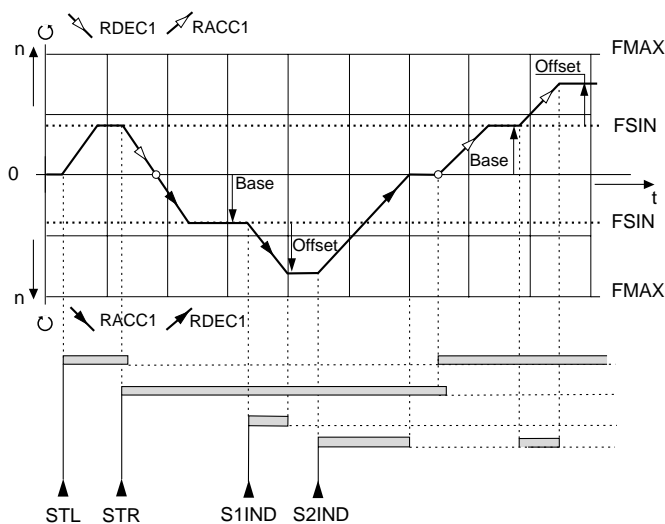

**Note:** When reversing, the signals at STL and STR must overlap by at least 0.5 s.

### Example: Reduction of the base value, reset offset with RSTOP

With setting parameter applies 04-FSSEL = 17/18/19/20/21/22

**Important:** The braking ramp RSTOP is only active, if a value  $\geq 1$  Hz/s is set in the parameter (factory setting = 0 Hz/s).

**Caution:** With the reduction of the base value to 0 Hz the drive comes to a stand still, however the condition should not be confused with a stop command. If the base value is raised while the S2IND signal is at hand, the drive is restarted (to new base value with old offset).

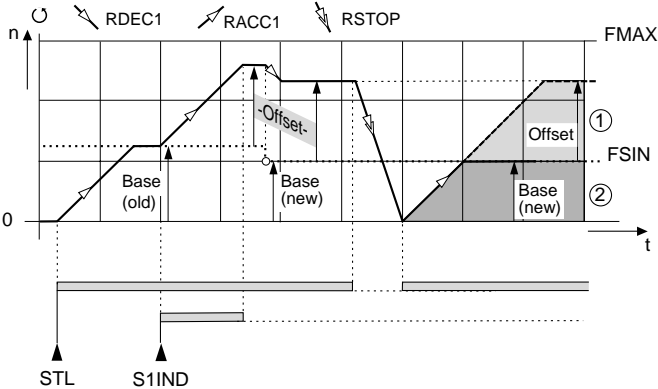

#### Key:

- ① Only possible with 04-FSSEL = 17/18/19/20  
(Offset is retained)
- ② Only possible with 04-FSSEL = 21/22  
(Offset is reset)

## Example: Saving the offset after power off



**Note:** If the mains is switched off, the drive comes to a stop by itself. When the mains is reconnected and a new start signal, the drive is accelerated from 0 Hz. If the STL contact remains active during power off, the drive does not start. The drive does not accelerate to the base value until after a new STL edge. If an automatic restart required after power return, the auto start function must be activated in the parameter 72-STRT.

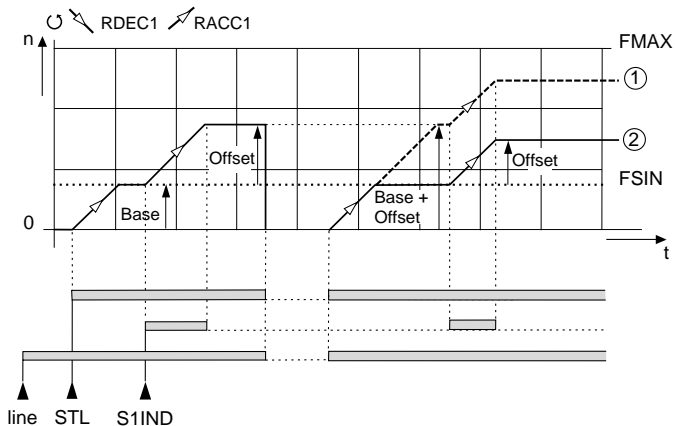

### Key:

- ① Offset is saved with power off (only possible with 04-FSSEL = 19/20).
- ② Offset is lost with power off (with 04-FSSEL = 17/18/21/22).

## 2.4.6 Signal outputs

### S1OUT ready

The message output is inactive (relay drops out) if there is a mains power supply failure, cable break or inverter malfunction. The relay picks up again when the malfunction has been rectified and the mains power has been reset.

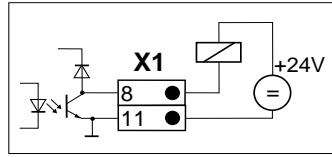

Connection S1OUT (freewheeling diode for relay switched in the inverter)

### S2OUT frequency converter

The message output is active (relay picks up) when the rotating field frequency exceeds the programmed value of the fixed frequency FF5. The relay drops out again when the value drops below the fixed frequency FF5.

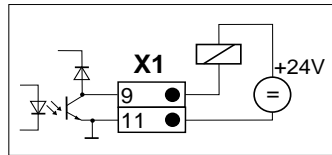

S2OUT connection (freewheeling diode for relay switched in the inverter).

### Programming:

Both outputs can be programmed to one of ten different functions using the **KEYPAD** or via the interface. The factory setting is as follows:

parameter 62-S1OUT = 1

parameter 63-S2OUT = 7

For further information, see description of parameters.

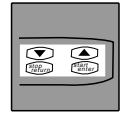

### SOUTA programmable output

The message output in the standard unit operates with the factory setting as an analog frequency output. It provides a DC signal which is proportional to the output frequency of the inverter.

Scaling:

| SOUTA | Explanation  |
|-------|--------------|
| 10 V  | F = FMAX     |
| 0,1 V | F = FMIN     |
| 0 V   | F = 0 (STOP) |

SOUTA connection

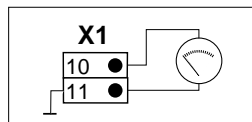

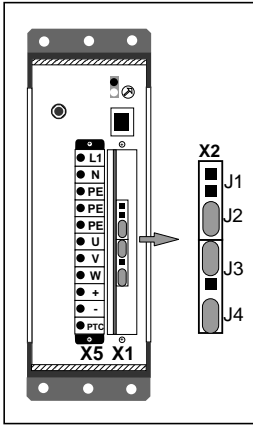

### Programming:

The SOUTA output can be switched to a pulse output by using jumpers X2/J3 and J4. It then operates as an open collector output and requires an external voltage (see 2.4.1, Specifications). Other functions are programmable using the parameter 61-SOUTA (see table).

In addition, the analog output 61-SOUTA can be scaled using the parameter 69-KOUTA (see parameter description).

| Item | J3 | J4 | Function                          | Comment                                    | 61-SOUTA |
|------|----|----|-----------------------------------|--|----------|
| A    |    |    | no function                       |  |          |
| B    |    |    | analog output                     | 0...10 V factory setting                   | 1        |
| C    |    |    | pulse output<br>open collector    | PWM 0% = 0 Hz*<br>PWM 100% = FMAX*         | 1        |
| D    |    |    | pulse output<br>open collector    | frequency signal =<br>6 x output frequency | 3        |
| E    |    |    | switched output<br>open collector | Frequency signal for<br>BC control         | 2        |
| F    |    |    | no function                       |  |          |

\*Not possible for versions I6 and I8.

#### C:

SOUTA operates as a pulsed output with a pulse-width modulated signal.

#### D:

SOUTA operates as a pulsed output with the pulse duty factor 1:1.6 LOW pulses are output to SOUTA for every 1 Hz rotating field frequency.

#### E:

If the intermediate circuit voltage of the inverter exceeds a certain limit and the inverter is started, then SOUTA output becomes active. It operates as a switched output (switching frequency < 1 kHz) which can drive an external braking chopper.

Factory setting:     61-SOUTA   = 1  
                          69-KOUTA   = 100 %

For further information, see description of parameters.

## 2.4.7 LUS<sup>T</sup>Bus connection

### Technical data:

|                       | <b>VF1000S,I5/I7 or I6/I8</b>             |
|-----------------------|---|
| Baud rate             | 9600, 4800, 2400, 1200 Baud <sup>1)</sup> |
| Supply voltage        | not applicable                            |
| Power consumption     | not applicable                            |
| Electrical isolation  | 2500 VDC                                  |
| RS485 driver capacity | max. 30 participants < 1000 m             |
| RS232 driver capacity | 1 participants < 10 m                     |

<sup>1)</sup> Transmission rate of the interface RS485;  
adjustable with parameter 81-SIOC; default = 9600 Baud

**Variant I5** (interface RS232 with potential-free analog input)

**Variant I7** (interface RS232 with potential-free PWM-input)

Terminal assignment (also see Fig. 1):

Terminal X1/5 = TxD (S1IND no longer available)

Terminal X1/6 = RxD (S2IND no longer available)

### Note:

No external supply voltage is necessary to operate the interface

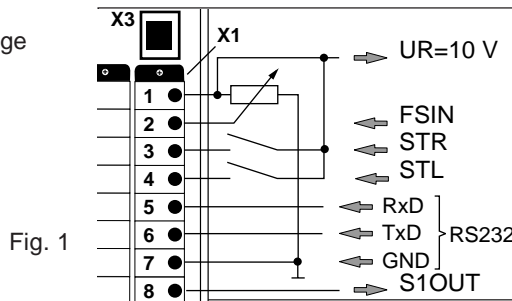

**Variante I8** (interface RS485 with potential-free analog input)

**Variante I6** (interface RS485 with potential-free PWM input)

**Terminal assignment** (also see Fig. 2):

Terminal X1/5 = R/T A (S1IND no longer available)

Terminal X1/6 = R/T B (S2IND no longer available)

Terminal. X1/10 = no function (SOUTA no longer available)



**Caution:**

RS485 transmission needs setting of data transmission direction. Hence setting of 61-SOUTA = 7 is necessary.

**Note:**

No external supply voltage is necessary to operate the interface.

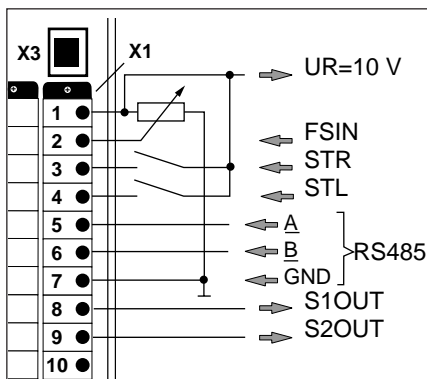
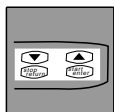

Fig. 2



**Programming:**

Through setting 61-SOUTA = 7 parameter 81-SIOC becomes active. This parameter can be edited on MODE = 3

| 81-SIOC | Transmission rate |
|---------|-------------------|
| 0       | 9600 Baud         |
| 1       | 4800 Baud         |
| 2       | 2400 Baud         |
| 3       | 1200 Baud         |

## 2.4.8 Frequency reference as PWM-signal (I1, I6, I7)

With the design codes I1, I6 and I7 the frequency reference signal shall be puls-width-modulated (PWM).

Scaling:

| 04-FSSEL | range          | A   |
|----------|----------------|-----|
| 5        | 20...100 % PWM | 0.2 |
| 6        | 0 ...100 % PWM | 0   |

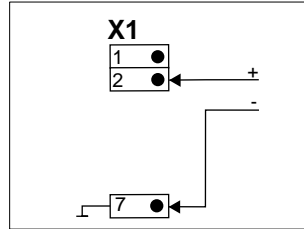

Pulse diagram:

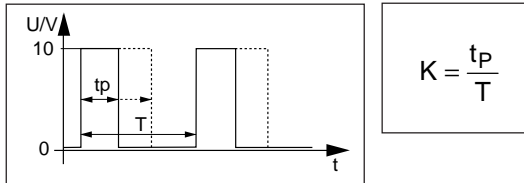

Reference formula:

$$FSIN[Hz] = \frac{FMAX - FMIN}{(1 - A)} \cdot (K - A) + FMIN$$

FMAX = value of 22-FMAX1

FMIN = value of 21-FMIN1

A = scaling factor

K = pulse/pause ratio

Technical data:

| PWM-reference input FSIN |          |                                   |
|--------------------------|----------|-----------------------------------|
| voltage                  | $U_{IN}$ | Low < 4 V, high > 5 V (10 V max.) |
| carrier frequency        | $F_G$    | 1 ... 8 kHz                       |



Example:

| <b>Setting<br/>04-FSSEL =</b> | <b>Ratio<br/>K =</b> | <b>Result<br/>FSIN =</b>       |
|-------------------------------|----------------------|--------------------------------|
| 5 (A = 0)                     | 0                    | FMIN                           |
| 5 (A = 0)                     | 0.6                  | $(FMAX - FMIN) * 0.6 + FMIN^*$ |
| 5 (A = 0)                     | 1                    | FMAX                           |

| <b>Setting<br/>04-FSSEL =</b> | <b>Ratio<br/>K =</b> | <b>Result<br/>FSIN =</b>       |
|-------------------------------|----------------------|--------------------------------|
| 6 (A = 0.2)                   | 0...0.2              | FMIN                           |
| 6 (A = 0.2)                   | 0.6                  | $(FMAX - FMIN) * 0,5 + FMIN^*$ |
| 6 (A = 0.2)                   | 1                    | FMAX                           |

\*Simplified formula

### 3 Operation and fault diagnostics

#### 3.1 Operation indicators

| H2<br>green | H1<br>red | Meaning  |
|-------------|-----------|--|
| ○           | ○         | Power off, no function   |
| ○           | ☀         | Power is switched on, after approximately 0.5 s Selftest, inverter ready             |
| ☀           | ○         | Inverter has been started  |
| ☀           | ☀         | Overload protection active   |
| ○           | ☀         | Fault-clearing, H1 flashing rhythm, see 3.2.1 Error Messages with equipment response |

Location of LEDs:

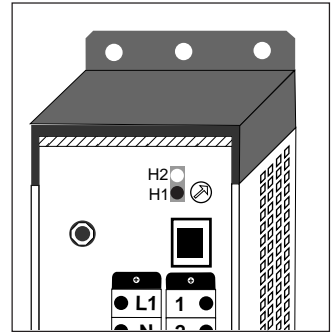

#### 3.2 Error messages

##### 3.2.1 Error messages with device response

| H1<br>flashes | Error | Status/cause                          | Remedy/comment                                       | Flashing<br>rhythm |
|---------------|-------|---------------------------------------|--|--------------------|
| Once          | E-CPU | Error in processor                    | Switch off at mains and switch back on (reset)       |                    |
| Twice         | E-OFF | Mains switched off or undervoltage    | flashes until UZK <150 V (VF12xxS) < 300 V (VF14xxS) |                    |
| 3 times       | E-OC  | Overcurrent switch-off short circuit  | Check drive/motor cable                              |                    |
| 4 times       | E-OV  | Overcurrent, motor – regenerative     | Check mains/drive                                    |                    |
| 5 times       | E-OLM | Motor overloaded, I * t switch-off    | Check drive/motor/ventilation                        |                    |
| 6 times       | E-OLI | Inverter overloaded, I * t switch-off | Check drive/ventilation                              |                    |
| 7 times       | E-OTM | Motor temperature too high            | Only possible with thermistor option                 |                    |
| 8 times       | E-OTI | Inverter temperature too high         | Inverter overloaded, check mounting conditions       |                    |
| 9 times       | E-EEP | Error in EE-PROM                      | Switch off mains and switch back on (reset)          |                    |

Acknowledge error by pressing the stop/return key for 3 sec. min.

### 3.2.2 Warning messages (no response to error by device)

#### VF1000 operating errors

|       |   |
|-------|---|
| ATT1  | Change of parameter in on-line operation (with motor running) not permitted.                    |
| ATT2  | Controlling motor via <b>KEYPAD</b> in on-line operation not permitted.                         |
| ATT3  | Access to <b>LUST SMARTCARD</b> in on-line operation not permitted.                             |
| ATT4  | System error. Controlling via <b>KEYPAD</b> not permitted.                                      |
| ATT5  | Motor data must be complete for the selected function, e.g. slip compensation must be complete. |
| ERROR | Invalid password  |

*Acknowledge error by pressing the start/enter key.*

#### Errors in SmartCard operation

|       |   |
|-------|---|
| ERR91 | <b>SMARTCARD</b> is write-protected                       |
| ERR92 | Error in validity check                                   |
| ERR93 | <b>SMARTCARD</b> not readable, inverter type incorrect.   |
| ERR94 | <b>SMARTCARD</b> not readable, parameters not compatible. |
| ERR96 | Connection to <b>SMARTCARD</b> broken.                    |
| ERR97 | <b>SMARTCARD</b> data invalid (CS test)                   |
| ERR98 | Insufficient memory on <b>SMARTCARD</b> (only MC6000)     |

*Acknowledge error by pressing the stop/return key.*

#### **Support:**

If you experience difficulties in commissioning the frequency inverter, we shall be pleased to assist as necessary. You can contact our trained engineers:

Address: Lust Antriebstechnik GmbH  
Gewerbestraße 5-9  
D-35633 Lahnau  
Germany

Telephone: +49 64 41 / 966-111  
Fax: +49 64 41 / 966-137

### 3.3 Motor/inverter overload protection (I\*t monitoring)

I\*t monitoring provides electronic motor protection and inverter protection against high thermal loads. The triggering characteristics may be seen from the diagram. The details refer to an output frequency of 50 Hz.

It should be noted that during continuous operation with frequencies < 40 Hz, the motor requires forced cooling.

#### General rule:

Within any 10 minute period, with a continuous current of  $I = 1.5 \cdot I_N$  (150% overload), an overload phase of 1 minute is possible.



Diagram:

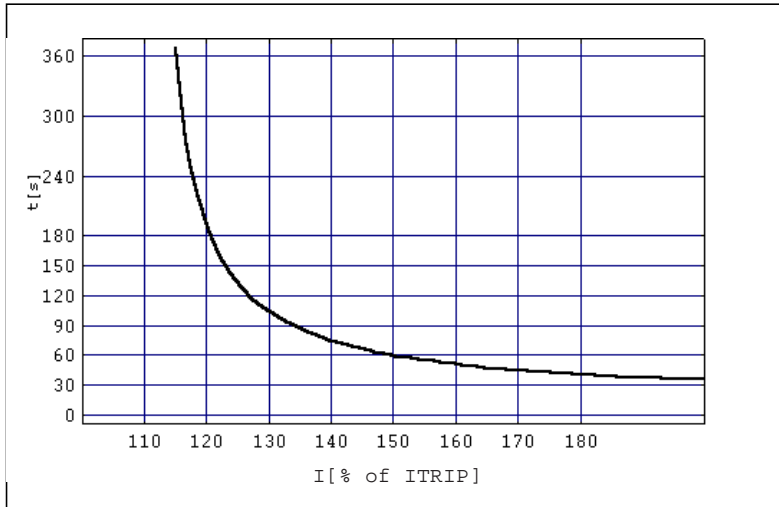

#### Programming:

The parameter 59-TRIP is used for setting the I\*t triggering current. The triggering characteristics represented in the diagram move in parallel to the left, according to the setting. This means that currents  $< I_N$  (device rated current) can be set. This means that motors with a lower power than the rated power can be protected adequately from overload. See also Description of parameters.



#### Factory setting:

59-TRIP =  $I_N$  (rated current for device)

## 4 Using the KP100 KEYPAD

### 4.1 Layout

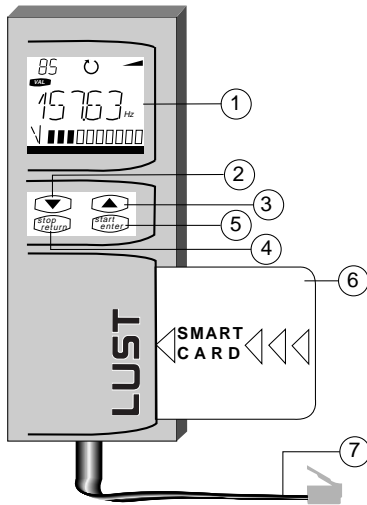

#### Warning:

Before connecting the KEYPAD to the VF1104S, VF1202S, VF1204S and VF1402S inverters, disconnect the mains power supply. The socket for the KEYPAD is live.



| Item | Code             | Function   |
|------|------------------|--|
| 1    | LCD display      | 140 segments, backlit green/red                  |
| 2    | Arrow key down   | Scroll back within the menu structure            |
| 3    | Arrow key up     | Scroll forwards within the menu structure        |
| 4    | Stop/return key  | Stop (CTRL menu), exit or leave selected menu    |
| 5    | Start/enter key  | Start (CTRL menu), confirm or select menu        |
| 6    | SMARTCARD        | Chipcard data memory, storage of device settings |
| 7    | Connecting cable | Maximum length 0.30 m                            |

#### Dimensions and weight

|                     |       |    |            |
|---------------------|-------|----|------------|
| Dimensions          | WxHxD | mm | 62x158x21  |
| Weight              | -     | g  | 100        |
| Protection          | -     | -  | VBG4, IP20 |
| Ambient temperature | T     | °C | 0...40     |

## 4.2 General

### 4.2.1 Menu options

After the power is switched on, the device runs a self-test (display backlit red).

The **VF1000** then goes straight to the current value of the output frequency (display backlit green).

The VAL menu option is active. By tapping the stop/return key twice, the display will change to menu and opens up the selection of other menu options.

|             |  |
|-------------|--|
| <b>VAL</b>  | = Display actual values                                |
| <b>PARA</b> | = Change parameter setting (parameterisation).         |
| <b>CTRL</b> | = Control motor using <b>KEYPAD</b>                    |
| <b>CARD</b> | = Load device settings/<br>store with <b>SMARTCARD</b> |

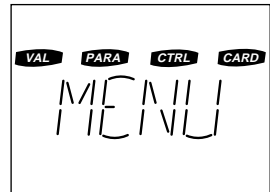

### 4.2.2 Key functions

The arrow keys are used for selecting menu options and specific parameters and enable changes to be made to them.

Tap them once and move to the next menu option or parameter or the smallest increment in a parameter value.

If a key is held down, it will scroll automatically and stop when the key is released.

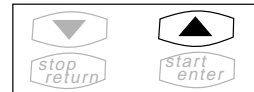
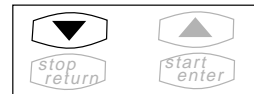

The stop/return key is used for leaving the menu options and for exiting from parameter changes (old value is retained).

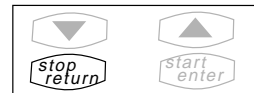

The start/enter key is used for calling up menu options or parameters and storing changes.

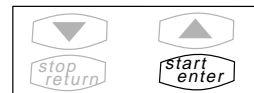

### 4.2.3 LCD display

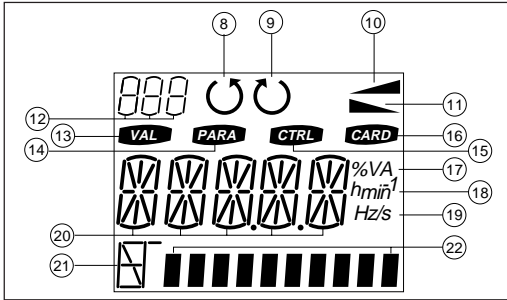

| Item | Description                 | Function   |
|------|-----------------------------|--|
| 8    | Anti-clockwise              | Monitors display for output rotating field, anti-clockwise active            |
| 9    | Clockwise                   | Monitors display for output rotating field, clockwise active                 |
| 10   | Acceleration ramp           | Monitors display, active during acceleration                                 |
| 11   | Braking ramp                | Monitors display, active during braking                                      |
| 12   | 3-digit display             | 7 segment display for actual values, parameter no.                           |
| 13   | VAL menu                    | Displays actual values e.g. frequency, voltage, current                      |
| 14   | PARA menu                   | Changes parameter setting  |
| 15   | CTRL menu                   | Controls motor via KEYPAD  |
| 16   | CARD menu                   | Loads/stores device setting with SMARTCARD                                   |
| 17   | Phys. unit for Item 20      | Displays %, V, A, VA with automatic classification                           |
| 18   | Phys. unit for Item 20      | Displays h, min <sup>-1</sup> with automatic classification                  |
| 19   | Phys. unit for Item 20      | Displays Hz, s, Hz/s with automatic classification                           |
| 20   | 5-figure display            | 15 segment display for parameter name and value                              |
| 21   | Bar chart code              | Displays formula characters and physical unit for Item 22                    |
| 22   | 10-figure bar chart display | Displays parameter values, frequency, voltage, apparent or effective current |

## 4.3 Menu structure

### 4.3.1 Overview

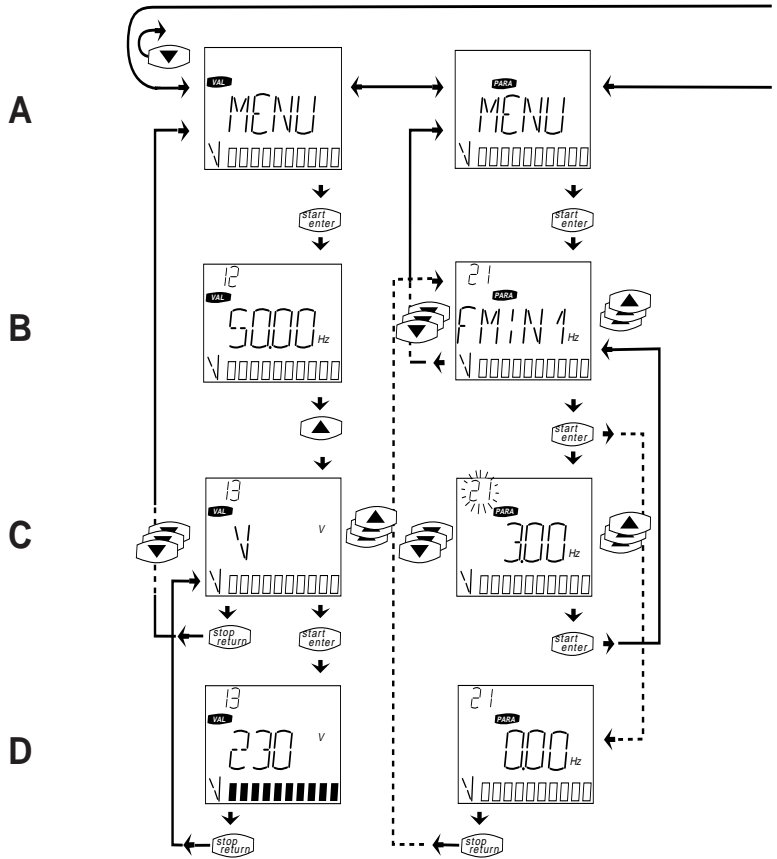

|          |  |   |
|----------|--|---|
| <b>A</b> | VAL menu (actual values) selected              | Menu PARA selected  |
| <b>B</b> | Display actual value, with arrow key change to | Select parameter, e.g. FMIN1                              |
| <b>C</b> | Next actual value parameter                    | Change parameter setting in off-line mode (inverter stop) |
| <b>D</b> | Establish new actual value                     | Read parameter setting in on-line mode (inverter start)   |



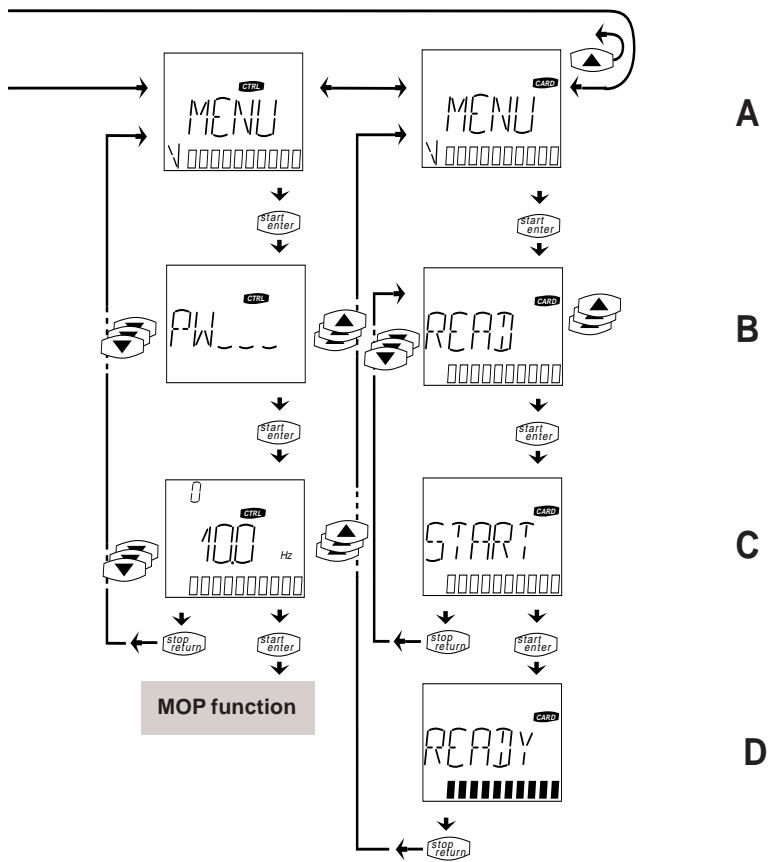

|          |   |  |
|----------|---|--|
| <b>A</b> | CTRL menu (control motor using KEYPAD) selected | Load/store menu device setting (GE) using the SMARTCARD (SC)   |
| <b>B</b> | Enter password<br>Factory setting = 573         | READ = load GE from SC<br>WRITE = save GE to SC<br>LOCK = write protect SC<br>UNLCK = remove write protect |
| <b>C</b> | Set frequency value (KEYPAD)<br>e.g. 10 Hz      | Start selected function using start/enter key  |
| <b>D</b> | Activation of MOP function (see next page)      | Function completed without error   |

### 4.3.2 MOP- function (motor operated potentiometer)

After password confirmation, the control terminal is blocked. The preset frequency reference value (KEYPAD) may be 10 Hz, for example. Start inverter by tapping the start/enter key.

Actual value (small display) and direction of rotation clockwise are also indicated..

Increase speed reference value using arrow key to e.g. 50 Hz.

Inverter follows with acceleration ramp for increase.

Reduce speed reference value using arrow keys.

Inverter follows with braking ramp for reduction. At < 0.0 Hz, the inverter changes the direction of the rotating field.

Increase speed reference value (anti-clockwise) to e.g. 10 Hz.

Prefix (-- ) also shows anti-clockwise direction.

Tap stop/return key: inverter brakes the motor to a stop.

The motor potentiometer function is reactivated with the start/enter key.

**From overview of CTRL menu**

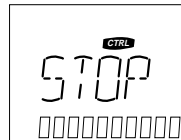
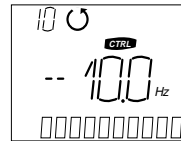
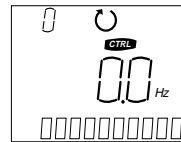
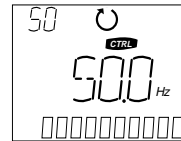
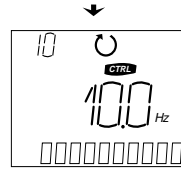

**To overview of CTRL menu**

## 5 Parameter list

### 5.1 Level 1

| Code  | Name                        | Unit | Display range                       | Page | Factory setting | Client setting |
|---|-----------------------------|------|-------------------------------------|------|-----------------|----------------|
| <b>Actual values</b>  |                             |      |                                     |      |                 |                |
| 10-G  | scaled frequency            | -    | 0 to 2000                           | 6-5  |                 |                |
| 12-F  | output frequency            | Hz   | 0.0 to 999.0                        | 6-5  |                 |                |
| 13-U  | output voltage              | V    | 0 to 460                            | 6-5  |                 |                |
| 14-IS   | apparent current            | A    | 0.0 to 52.0                         | 6-5  |                 |                |
| 15-IW   | effective current           | A    | 0.0 to 52.0                         | 6-5  |                 |                |
| 16-PW   | effective power             | W    | 0 to 22000                          | 6-5  |                 |                |
| 17-UZK  | ZK voltage                  | VDC  | 0 to 900                            | 6-5  |                 |                |
| 18-TIME   | switch-on delay after reset | h    | 0.0 to 960.0                        | 6-6  |                 |                |
| 19-TOP  | operating hours             | h    | 0 to 60000                          | 6-6  |                 |                |
| <b>Device data</b>  |                             |      |                                     |      |                 |                |
| 91-TYPE   | inverter type               | -    | 15 types possible                   | 6-18 |                 |                |
| 92-REV  | software version            | -    | -                                   | 6-18 |                 |                |
| 95-ERR1   | last error                  | -    | 0-0.0 to 9-1.5<br>11-0.0 to 11 -1.5 | 6-18 |                 |                |
| <b>Code Name Unit Setting range Page Factory setting Client setting</b> |                             |      |                                     |      |                 |                |
| 1-MODE  | operating mode              | -    | 0 to 4                              | 6-1  | 1               |                |
| <b>Frequencies</b>  |                             |      |                                     |      |                 |                |
| 20-FF2-1  | fixed frequency 2           | Hz   | 0.0 to 999.0                        | 6-6  | 3               |                |
| 21-FMIN1  | minimum frequency           | Hz   | 0.0 to 999.0                        | 6-6  | 0               |                |
| 22-FMAX1  | maximum frequency           | Hz   | 4.0 to 999.0                        | 6-6  | 50              |                |
| 23-FF3  | fixed frequency 3           | Hz   | 0.0 to 999.0                        | 6-6  | 15              |                |
| 24-FF4  | fixed frequency 4           | Hz   | 0.0 to 999.0                        | 6-6  | 30              |                |
| 25-FF5  | comparison frequency S2OUT  | Hz   | 0.0 to 999.0                        | 6-6  | 3               |                |
| <b>Ramps</b>  |                             |      |                                     |      |                 |                |
| 32-RACC1  | acceleration ramp 1         | Hz/s | 0.1 to 999.0                        | 6-7  | 20              |                |
| 33-RDEC1  | deceleration ramp 1         | Hz/s | 0.1 to 999.0                        | 6-7  | 20              |                |
| 36-RSTOP  | STOP deceleration ramp      | Hz/s | 0.0 to 999.0                        | 6-8  | 0               |                |
| <b>Characteristics</b>  |                             |      |                                     |      |                 |                |
| 41-V/FC   | U/F characteristic selector | -    | 1 and 4                             | 6-8  | 1               |                |
| 42-VB1  | start voltage (boost 1)     | %    | 0.0 to 25.0                         | 6-9  | 8               |                |
| 43-FN1  | rated frequency             | Hz   | 26.0 to 960.0                       | 6-9  | 50              |                |
| 44-VN1  | rated voltage               | V    | *                                   | 6-9  | *               |                |

\*Depends on inverter type

## 5.2 Level 2

| Code                             | Name                            | Unit | Setting range   | Page | Factory setting | Client setting |
|----------------------------------|---------------------------------|------|-----------------|------|-----------------|----------------|
| <b>Reference value selection</b> |                                 |      |                 |      |                 |                |
| 4-FSSEL                          | Frequency ref. selector         | -    | 0 to 23         | 6-1  | 4               |                |
| <b>Actual values</b>             |                                 |      |                 |      |                 |                |
| 9-BARG                           | Bar chart                       | -    | 6 actual values | 6-4  | 12-F            |                |
| <b>Frequencies</b>               |                                 |      |                 |      |                 |                |
| 20-FF2-1                         | 1st fixed frequency 2           | Hz   | 0.0 to 999.0    | 6-6  | 3               |                |
| 21-FMIN1                         | 1st minimum frequency           | Hz   | 0.0 to 999.0    | 6-6  | 0               |                |
| 22-FMAX1                         | 1st maximum frequency           | Hz   | 4.0 to 999.0    | 6-6  | 50              |                |
| 23-FF3                           | fixed frequency 3               | Hz   | 0.0 to 999.0    | 6-6  | 15              |                |
| 24-FF4                           | fixed frequency 4               | Hz   | 0.0 to 999.0    | 6-6  | 30              |                |
| 25-FF5                           | comparison frequency for S2OUT  | Hz   | 0.0 to 999.0    | 6-6  | 3               |                |
| 26-FF6                           | control frequency (data record) | Hz   | 0.0 to 999.0    | 6-6  | 0               |                |
| 27-FF2-2                         | 2nd fixed frequency 2           | Hz   | 0.0 to 999.0    | 6-6  | 5               |                |
| 28-FMIN2                         | 2nd minimum frequency           | Hz   | 0.0 to 999.0    | 6-6  | 0               |                |
| 29-FMAX2                         | 2nd maximum frequency           | Hz   | 4.0 to 999.0    | 6-6  | 50              |                |
| <b>Ramps</b>                     |                                 |      |                 |      |                 |                |
| 31-KSEL                          | data-record selector            | -    | 0 to 3          | 6-7  | 0               |                |
| 32-RACC1                         | 1st acceleration ramp           | Hz/s | 0.1 to 999.0    | 6-7  | 20              |                |
| 33-RDEC1                         | 1st deceleration ramp           | Hz/s | 0.1 to 999.0    | 6-7  | 20              |                |
| 34-RACC2                         | 2nd acceleration ramp           | Hz/s | 0.1 to 999.0    | 6-8  | 80              |                |
| 35-RDEC2                         | 2nd deceleration ramp           | Hz/s | 0.1 to 999.0    | 6-8  | 80              |                |
| 36-RSTOP                         | STOP deceleration ramp          | Hz/s | 0.0 to 999.0    | 6-8  | 0               |                |
| <b>Characteristics</b>           |                                 |      |                 |      |                 |                |
| 38-THTDC                         | switch-off delay                | s    | 0.0 to 120.0    | 6-8  | 0               |                |
| 39-VHTDC                         | DC holding voltage              | %    | 1 to 25         | 6-8  | 4               |                |
| 41-V/FC                          | U/F characteristic selector     | -    | 1 and 4         | 6-8  | 1               |                |
| 42-VB1                           | start voltage (boost 1)         | %    | 0.0 to 25.0     | 6-9  | 8               |                |
| 43-FN1                           | rated frequency 1               | Hz   | 26.0 to 960.0   | 6-9  | 50              |                |
| 44-VN1                           | rated voltage 1                 | V    | *               | 6-9  | *               |                |
| 45-VB2                           | start voltage (boost 2)         | %    | 0.0 to 25.0     | 6-9  | 8               |                |
| 46-FN2                           | rated frequency 2               | Hz   | 26.0 to 960.0   | 6-9  | 50              |                |
| 47-VN2                           | rated voltage 2                 | V    | *               | 6-9  | *               |                |

\*Depends on inverter type

## Operating level 2 (part 2)

| Code                     | Name                                     | Unit | Setting range          | Page | Factory setting | Client setting |
|--------------------------|--|------|------------------------|------|-----------------|----------------|
| <b>Special functions</b> |  |      |                        |      |                 |                |
| 48-IXR                   | I x R compensation                       | -    | 0 to 3                 | 6-10 | 0               |                |
| 49-SC                    | slip compensation                        | -    | 0 to 2                 | 6-11 | 0               |                |
| 50-IN                    | rated motor current                      | A    | *                      | 6-11 | *               |                |
| 51-COS                   | power factor x100                        | %    | 0 to 100               | 6-11 | 0.75            |                |
| 52-NN                    | motor nominal speed                      | RPM  | 0 to 60000             | 6-11 | 1390            |                |
| 53-KIXR                  | correction factor of IxR compensation    | -    | 0 to 30                | 6-12 | 5               |                |
| 54-KSC                   | correction factor of slip compensation   | -    | 0.0 to 20.0            | 6-12 | 9.75            |                |
| 55-ISEL                  | current controller selector              | -    | 0 to 2                 | 6-12 | 0               |                |
| 56-ILIM                  | current limit                            | A    | *                      | 6-14 | *               |                |
| 57-FILIM                 | min. reduction freq.                     | Hz   | 0.0 to 999.0           | 6-14 | 15              |                |
| 58-RILIM                 | delay ramp for current control           | Hz/s | 0.1 to 999.0           | 6-14 | 50              |                |
| 59-TRIP                  | I x t monitoring                         | A    | *                      | 6-14 | *               |                |
| <b>Signal outputs</b>    |  |      |                        |      |                 |                |
| 61-SOUTA                 | frequency/analog output                  | -    | 0 to 7                 | 6-15 | 1               |                |
| 62-S1OUT                 | output 1, digital                        | -    | 0 to 10                | 6-15 | 1               |                |
| 63-S2OUT                 | output 2, digital                        | -    | 0 to 10                | 6-15 | 7               |                |
| 64-SINA                  | internal potentiometer P1                | -    | 0 to 2                 | 6-16 | 0               |                |
| 67-FST                   | filter time constants                    | -    | 0 to 4                 | 6-16 | 2               |                |
| 69-KOUTA                 | SOUTA scaling                            | %    | 0 to 200               | 6-16 | 100             |                |
| <b>Program functions</b> |  |      |                        |      |                 |                |
| 71-PROG                  | special programs                         | -    | 0 to 4                 | 6-16 | 0               |                |
| 72-STRT                  | start options                            | -    | 0 to 7                 | 6-17 | 0               |                |
| 74-PWM                   | modulation frequency                     | -    | 0 to 2                 | 6-17 | 0               |                |
| 86-KG                    | scaling factor for 10-G                  | -    | 0 to 200               | 6-18 | 0               |                |
| 87-DISP                  | continuously stored actual value display | -    | all display parameters | 6-18 | 12-F            |                |
| 88-PSW1                  | password 1 <PARA>                        | -    | 0.0 to 999.0           | 6-18 | 0               |                |
| 89-PSW2                  | password 2 <CTRL>                        | -    | 0.0 to 999.0           | 6-18 | 573             |                |
| 94-MAXF                  | absolute max. frequency                  | Hz   | 4.0 to 999.0           | 6-18 | 50              |                |

\*Depends on inverter type

### 5.3 Inverter-dependent and country-related parameters

| Code                              | Name                | Unit | WE Europe | WE USA | Page | Inverter type |
|-----------------------------------|---------------------|------|-----------|--------|------|---------------|
| 44-VN1                            | rated voltage 1     | V    | 110       | 115    | 6-9  | VF1104S       |
| 44-VN1                            | rated voltage 1     | V    | 220       | 230    | 6-9  | VF1202S       |
| 44-VN1                            | rated voltage 1     | V    | 220       | 230    | 6-9  | VF1204S       |
| 44-VN1                            | rated voltage 1     | V    | 380       | 460    | 6-9  | VF1402S       |
| 47-VN2                            | rated voltage 2     | V    | 110       | 115    | 6-9  | VF1104S       |
| 47-VN2                            | rated voltage 2     | V    | 220       | 230    | 6-9  | VF1202S       |
| 47-VN2                            | rated voltage 2     | V    | 220       | 230    | 6-9  | VF1204S       |
| 47-VN2                            | rated voltage 2     | V    | 380       | 460    | 6-9  | VF1402S       |
| 50-IN                             | rated motor current | A    | 3.2       | 4      | 6-11 | VF1104S       |
| 50-IN                             | rated motor current | A    | 1.9       | 2      | 6-11 | VF1202S       |
| 50-IN                             | rated motor current | A    | 3.2       | 3.6    | 6-11 | VF1204S       |
| 50-IN                             | rated motor current | A    | 1.9       | 1.8    | 6-11 | VF1402S       |
| 56-ILIM                           | current limit       | A    | 4.8       | 4.8    | 6-14 | VF1104S       |
| 56-ILIM                           | current limit       | A    | 2.85      | 2.85   | 6-14 | VF1202S       |
| 56-ILIM                           | current limit       | A    | 4.8       | 4.8    | 6-14 | VF1204S       |
| 56-ILIM                           | current limit       | A    | 2.85      | 2.85   | 6-14 | VF1402S       |
| 59-TRIP                           | l x t monitoring    | A    | 3.2       | 3.2    | 6-14 | VF1104S       |
| 59-TRIP                           | l x t monitoring    | A    | 1.9       | 1.9    | 6-14 | VF1202S       |
| 59-TRIP                           | l x t monitoring    | A    | 3.2       | 3.2    | 6-14 | VF1204S       |
| 59-TRIP                           | l x t monitoring    | A    | 1.9       | 1.9    | 6-14 | VF1402S       |
| <b>Country-related parameters</b> |                     |      |           |        |      |               |
| 22-FMAX1                          | maximum frequency 1 | Hz   | 50        | 60     | 6-6  |               |
| 29-FMAX2                          | maximum frequency 2 | Hz   | 50        | 60     | 6-6  |               |
| 43-FN1                            | rated frequency 1   | Hz   | 50        | 60     | 6-9  |               |
| 46-FN2                            | rated frequency 2   | Hz   | 50        | 60     | 6-9  |               |
| 52-NN                             | nominal speed       | RPM  | 1390      | 1710   | 6-11 |               |

#### Factory setting (WE)

The factory setting can be set using the **KEYPAD** in the **PARA** menu. To do this, parameter 71-PROG must be set to 1 (European version) or 71-PROG to 4 (USA version).

## 6 Description of parameters

### 01-MODE Operating mode [decimal]

MODE determines the control options of the inverter and the effective operating level for the KP100 KEYPAD.

The parameters are divided into five operating levels.

01-MODE = 0 -> parameter 02-CSEL can be changed by serial communication only.

01-MODE = 1 -> set of typical parameters for commissioning.

01-MODE = 2 -> extended parameter set with special functions.

01-MODE = 3 -> for serial communication and special parameters.

01-MODE = 4 -> for CAN-Bus and INTERBUS-S operation.

### 6.1 Reference value selection

#### 04-FSSEL Frequency reference value selector

Provides the choice between various types of reference value (analog, frequency or PWM signal) and their means of input (KEYPAD, SIO,...).

| 04-FSSEL | Function   |
|----------|--|
| 0        | integral P1 potentiometer active   |
| 1/2/3    | not active   |
| 4        | analog input active, matching using jumper strip X2  |
| 5        | FSIN as PWM input 20 to 100% active *  |
| 6        | FSIN as PWM input 0 to 100% active *   |
| 7        | FSIN not active, ref. value from KP100 (CTRL menu)   |
| 8        | reference value via interface**  |
| 9 to 16  | for reference value selection, see Page 6-4, Chap. 6.                                      |
| 17 to 22 | correction of analog reference value via S1IND/S2IND (motor potentiometer function active) |
| 23       | inverted analog input, 10 V = FMIN, 0V = FMAX  |

\*Only possible for models I1, I6 (PWM input), see Section A.3

\*\*Only possible for models I5, I6 or I8

## Block diagram of reference value input

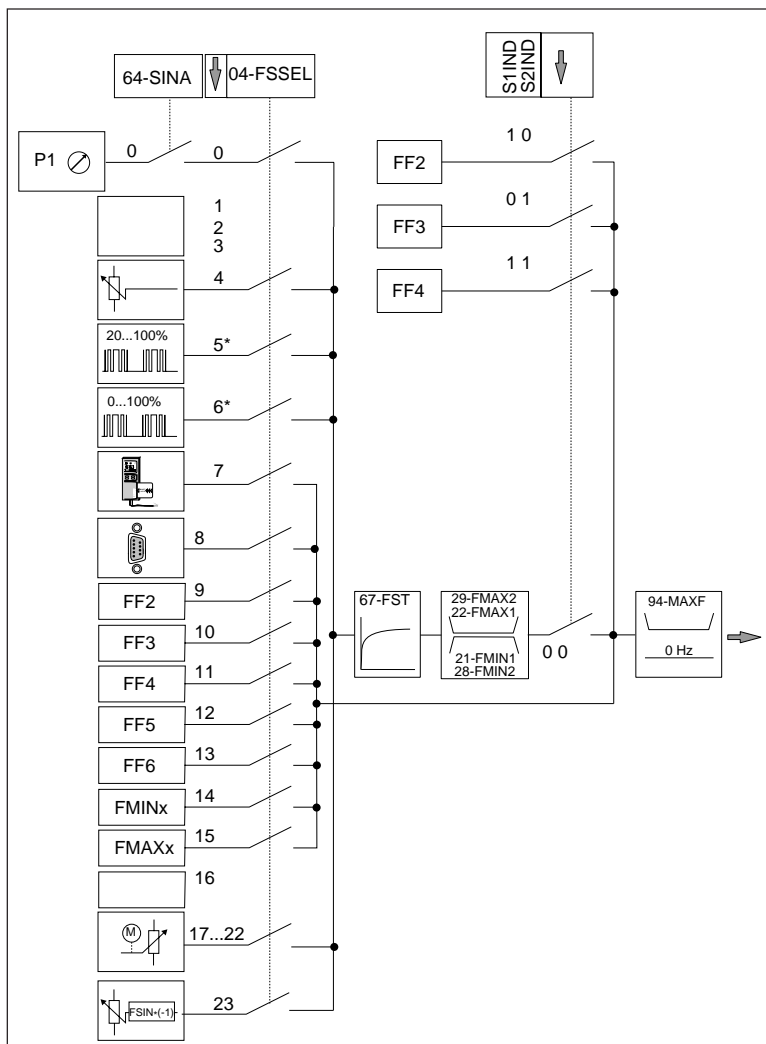

\*Only possible for models i1, i6 (PWM input), see Section A.3

*04-FSSEL = 0*

FSIN input not active. Integral potentiometer P1 (parameter 64-SINA = 0) used for reference value selection.

*04-FSSEL = 1, 2, 3*

FSIN input and integral potentiometer P1 not active.

*04-FSSEL = 4*

FSIN input is active as an analog input. Matching to 0(2)...10 V or 0(4) ...20 mA is achieved via jumper strip X2.



04-FSSEL = 5\*

FSIN input works as pulse input for the pulse-width modulated signal.

FMIN = 20% PWM FMAX = 100% PWM. See diagram.

04-FSSEL = 6\*

FSIN input works as pulse input for pulse-width modulated signal.

FMIN = 0% PWM FMAX = 100% PWM. See diagram.

\* Only possible for models I1, I6 (PWM input), see Section A.3

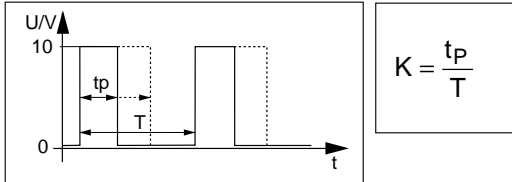

$$FSIN[Hz] = \frac{FMAX - FMIN}{(1 - A)} \cdot (K - A) + FMIN$$

| 04-FSSEL | Adjustment range | A   |
|----------|------------------|-----|
| 5        | 20...100% PWM    | 0.2 |
| 6        | 0 ...100% PWM    | 0   |

04-FSSEL = 7

FSIN input is not active. The reference value is set using the **KEYPAD**. When the motor potentiometer function is started using the **CTRL** menu of the **KEYPAD**, 04-FSSEL = 7 is automatically set.

04-FSSEL = 8 (only possible for models I5, I6 or I8)

FSIN and **KEYPAD** inputs are not active. The reference value can only be set externally via the interface.

04-FSSEL = 9

Reference value is set to the 20-FF2-1 or 27-FF2-2 value (note 31-KSEL data-record switching). FSIN input is not active.

04-FSSEL = 10

Reference value is set to the 23-FF3 value. The FSIN input is not active.

04-FSSEL = 11

Reference value is set to the 24-FF4 value. The FSIN input is not active.

04-FSSEL = 12

Reference value is set to the 25-FF5 value. The FSIN input is not active.

04-FSSEL = 13

Reference value is set to the 26-FF6 value. The FSIN input is not active.

04-FSSEL = 14

Reference value is set to the 21-FMIN1 or 28-FMIN2 value (note 31-KSEL data-record switching). The FSIN input is not active.

*04-FSSEL = 15*

Reference value is set to the 22-FMAX1 or 29-FMAX2 value (note 31-KSEL data-record switching). FSIN input is not active.

*04-FSSEL = 16*      No entry.

*04-FSSEL = 17<sup>1)</sup>*

FSIN output is active (basis reference value). The reference value can be continuously increased using S1IND and continuously reduced using S2IND (reference value offset with motor potentiometer function).

*04-FSSEL = 18<sup>1)</sup>*

This has the same function as 04-FSSEL = 17 but with the following addition: if S1IND and S2IND are both activated simultaneously, the reference value is reset to the basic reference value (reference value offset = 0).

*04-FSSEL = 19<sup>1)</sup>*

This has the same function as 04-FSSEL = 18 but with the following addition: with the reference value offset and power off, this offset is stored until it is changed or reset using S1IND or S2IND.

*04-FSSEL = 20<sup>1)</sup>*

This has the same function as 04-FSSEL = 18 and 19.

*04-FSSEL = 21<sup>1)</sup>*

This has the same function as 04-FSSEL = 18 with the following addition: when the inverter stops, the reference value is reset to the base reference value (reference value offset = 0).

*04-FSSEL = 22<sup>1)</sup>*

This has the same function as 04-FSSEL = 18 and 21

*04-FSSEL = 23<sup>1)</sup>*

The FSIN input operates as an inverted analog input.

FMIN = 10 V

FMAX = 0 V

<sup>1)</sup> See description of the MOP function with S1IND/S2IND in Chapter 2.4.5.

## 6.2 Actual values

### 09-BARG Bar chart display [decimal]

The following parameters can be represented on the bar-chart display.

| 09-BARG | Function   |
|---------|--|
| STAT    | Represents as bit pattern, see Fig. 1                      |
| 12-F    | Output frequency as analog bar, code < F >                 |
| 13-V    | Output voltage as analog bar, code < V > (factory setting) |
| 14-IS   | Apparent current as analog bar, code < I >                 |
| 15-IW   | Effective current as analog bar, code < I >                |
| SIN     | Represents as bit pattern, see Fig. 2                      |

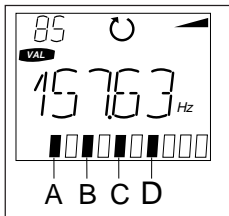

Fig. 1

- A -> regenerative current
- B -> current limit val. reached  $I_s > 110\% I_N$
- C -> 12-F > FF5
- D -> reference value attained

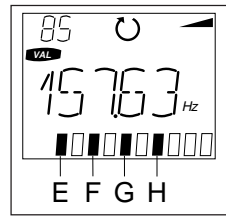

Fig. 2

- E -> S2OUT active
- F -> S1OUT active
- G -> S2IND active
- H -> S1IND active

**10-G Scaled frequency**

Shows the current output frequency 12-F multiplied by the factor from parameter 86-KG. No decimal places or physical units are displayed. (Factory setting = 0).

$$(10-G) = (12-F) * (86-KG)$$

**12-F Output frequency [Hz]**

Displays the current output frequency. After fault-clearing, the actual value that existed immediately before clearing is stored (hold function).

**13-V Output voltage [V]**

Displays the current output voltage. The output voltage is held constant irrespective of the ZK voltage if there is a control reserve present (ZK compensation). After fault-clearing, the actual value present immediately before clearing is stored (hold function).

**14-IS Phase current [A]**

Displays the current phase apparent current. After fault-clearing, the actual value that existed immediately before clearing is stored (hold function).

**15-IW Effective current [A]**

Displays the current phase effective current. After fault clearing, the actual value that existed immediately before clearing is stored (hold function).

**16-PW Effective power**

Displays the effective power produced by the inverter.

$$(16 - PW) = \sqrt{3} * (15 - IW) * (13 - V)$$

**17-VZK Intermediate circuit voltage [VDC]**

Displays the current intermediate circuit voltage. After fault-clearing, the actual value that existed immediately before clearing is stored (hold function).

**18-TIME Switch-on delay since reset [0.1 h]**

Displays time on since the last time the mains supply was switched on.

**19-TOP Operating hours [h]**

Displays the total operating hours. The maximum value of the operating hour counter is 60000. When it reaches this value, it remains unchanged.

## 6.3 Frequencies

### **20-FF2-1 Fixed frequency FF2-1 [Hz]**

Parameter of 1st data record. Factory setting = 3 Hz

Selectable as reference value using S1IND = 1 and S2IND = 0

### **21-FMIN1 Minimum freq. for analog reference value selection [Hz]**

Parameter of 1st data record. (Factory setting = 0 Hz). Setting reference value FSIN = 0(2)V or 0(4)mA corresponds to an output frequency of FMIN.

### **22-FMAX1 Maximum freq. for setting analog reference value [Hz]**

Parameter of 1st data record. (Factory setting = 50 Hz). Setting reference value FSIN = 10 V or 20 mA corresponds to an output frequency of FMAX.

### **23-FF3 Fixed frequency FF3 [Hz]**

Selectable as reference value using S1IND = 0 and S2IND = 1

(Factory setting = 15 Hz)

### **24-FF4 Fixed frequency FF4 [Hz]**

Selectable as reference value using S1IND = 1 and S2IND = 1

(Factory setting = 30 Hz)

### **25-FF5 Fixed frequency FF5 [Hz]**

Frequency threshold for programmable outputs S1OUT, S2OUT (see also 62-S1OUT 63-S2OUT). (Factory setting = 3 Hz)

### **26-FF6 Fixed frequency FF6 [Hz]**

Frequency threshold for data-record switching where 31-KSEL = 1

(Factory setting = 0 Hz)

### **27-FF2-2 Fixed frequency FF2-2 [Hz]**

Parameter of the 2nd data record. (Factory setting = 5 Hz)

Selectable as reference value using S1IND = 1 and S2IND = 0

### **28-FMIN2 Minimum freq. for setting analog reference value [Hz]**

Parameter of 2nd data record (see also 21-FMIN1).

### **29-FMAX2 Maximum freq. for setting analog reference value [Hz]**

Parameter of 2nd data record. (see also 22-FMAX1)

## 6.4 Ramps

### 31-KSEL Data-record selector

The data-record selector determines the control value for data-record switching. Possible control values for data-record switching are:

| 31-KSEL | Function   | Application example                                |
|---------|--|--|
| 0       | Data-record switching inactive, always data record 1   | Standard, factory setting                          |
| 1       | Switching to 2nd data record, when 12-F > FF6  | Heavy load start                                   |
| 2       | Switching of data records with S2IND, no activity with motor potentiometer function (04-FSSEL = 17...18) | Alternate use of 2 motors on 1 inverter            |
| 3       | Switching to 2nd data record for anti-clockwise operation (STL active)                                   | Drive with load depending on-direction of rotation |

Two data records with the following parameters are available.

| Parameter         | Data record 1 | Data record 2 |
|-------------------|---------------|---------------|
| Minimum frequency | 21-FMIN1      | 28-FMIN2      |
| Maximum frequency | 22-FMAX1      | 29-FMAX2      |
| Fixed frequency 2 | 20-FF2-1      | 27-FF2-2      |
| Acceleration ramp | 32-RACC1      | 34-RACC2      |
| Braking ramp      | 33-RDEC1      | 35-RDEC2      |
| Voltage rise      | 42-VB1        | 45-VB2        |
| Rated voltage     | 44-VN1        | 47-VN2        |
| Rated frequency   | 43-FN1        | 46-FN2        |

### 32-RACC1 Acceleration ramp [Hz/s]

Parameter of 1st data record. (Factory setting = 20 Hz/s)

### 33-RDEC1 Deceleration ramp [Hz/s]

Parameter of 1st data record. (Factory setting = 20 Hz/s)

### 34-RACC2 Acceleration ramp [Hz/s]

Parameter of the 2nd data record. (Factory setting = 80 Hz/s)

### 35-RDEC2 Deceleration ramp [Hz/s]

Parameter of the 2nd data record. (Factory setting = 80 Hz/s)

DS1 = Data record 1  
 DS2 = Data record 2

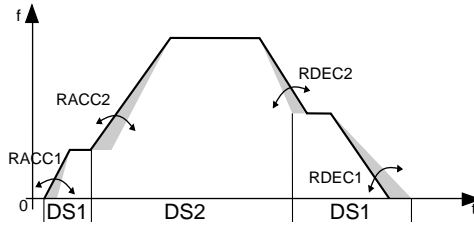

**36-RSTOP Stop ramp [Hz/s]**

When the stop ramp (36-RSTOP > 0) is activated, the inverter executes a deceleration ramp of gradient 36-RSTOP after setting the control inputs STR and STL to 0 (contacts open). A subsequent DC current hold is possible using 38-THTDC > 0.

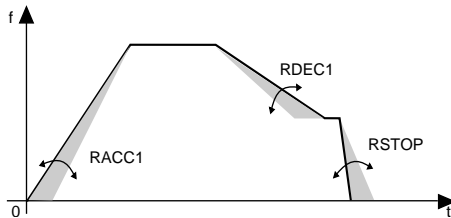

**6.5 Characteristics**

**38-THTDC DC current-hold switch-off delay [s]**

DC current hold becomes active once the value drops below the switch-off current limit (FSIN < 0.5 Hz). Braking can be either from 33-RDEC1 or 36-RSTOP. The hold time can be set to a value up to 120 seconds.

**39-VHTDC DC current-hold voltage level [%]**

The output voltage for DC current hold can be set using parameter 39-VHTDC as a % of the rated voltage of the device. (Factory setting = 4%)

**41-V/FC Characteristic selector [decimal]**

- 41-V/FC = 1 -> linear voltage frequency characteristics (WE)
- 4 -> quadratic voltage frequency characteristics

See also the diagrams on page 6-10.

**42-VB1 Voltage rise [%]**

Parameter of 1st data record. Voltage at frequency 0 Hz. Rise in torque in start-up range. (Factory setting = 8%)  
See also diagrams below.

**43-FN1 Rated frequency [Hz]**

Parameter of the 1st data record. Frequency at which the inverter achieves the maximum output voltage. (Factory setting = 50 Hz)  
See also diagrams below.

**44-VN1 Rated voltage [V]**

Parameter of the 1st data record. Initial setting of voltage which the inverter should have attained when it reaches 43-FN1.  
See also diagrams below.

**45-VB2 Voltage rise [%]**

Parameter of the 2nd data record (see 42-VB1).  
See also diagrams below.

**46-FN2 Rated frequency [Hz]**

Parameter of the 2nd data record. See 43-FN1.  
See also diagrams below.

**47-VN2 Rated voltage [V]**

Parameter of the 2nd data record. See 44-VN1.  
See also diagrams below.

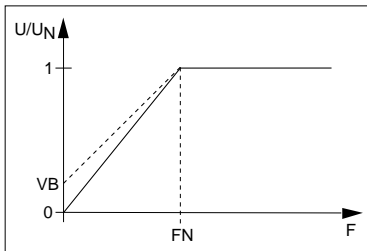

$41-V/FC = 1$

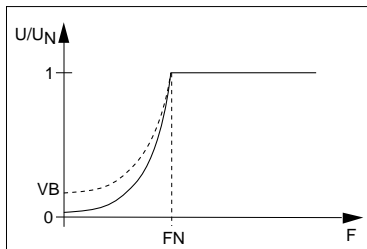

$41-V/FC = 4$



## 6.6 Special functions

### 48-IXR Automatic load regulation (I\*R compensation))

- 48-IXR = 0 -> I\*R compensation not active  
 1 -> I\*R compensation active with 1st and 2nd data record  
 2 -> I\*R compensation only active with 1st data record  
 3 -> I\*R compensation only active with 2nd data record

Requirement for activation of I\*R compensation:  
 enter motor data (on type plate) **50-IN**, **51-COS** and **52-NN** for  
 the load characteristics.

The aim of I\*R compensation is to produce constant torque and reduce heating of the motor windings. This is achieved when the load characteristics as determined by the characteristic parameters are displaced by an amount  $\Delta U$  which depends on the effective current.  
 See Figure A.

|   |   |
|---|---|
| $\Delta U = (I_W - I_N \cdot \cos\phi) \cdot K_{IXR}$ | $I_W$ = 15-IW (effective current)<br>$I_N$ = 50-IN (motor rated current)<br>$\cos\phi$ = 51-COS (cosφ motor)<br>$K_{IXR}$ = 53-KIXR (correction factor) |
|---|---|

I\*R compensation begins from frequency  $V_B \cdot F_N$ . It increases in a linear fashion: from 0% of frequency  $V_B \cdot F_N$  to 100% at frequency  $2 \cdot V_B \cdot F_N$ . Beyond that it is 100%. See Figure B.

Fig.A

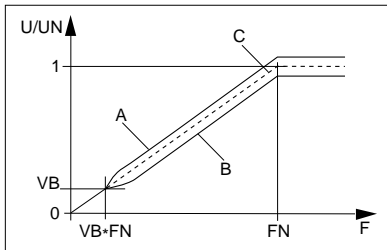
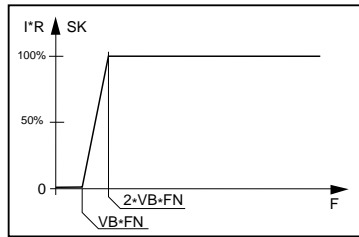

Fig. B



- A ->  $I_W$  = rated current (rated load)      Proportion of I\*R compensation (I\*R)  
 B ->  $I_W = 0$  (free speed)                      Proportion of slip compensation (SK)  
 C -> non-compensated characteristic

## 49-SC Slip compensation on/off (SK)

- 49-SC = 0 -> Slip compensation not active  
1 -> Slip compensation active with 1st and 2nd data records  
2 -> Slip compensation only active with first data record only

Requirement for activating (SK):

Enter motor data (type plate) **50-IN**, **51-COS** and **52-NN**.

Slip compensation is intended to keep the speed constant irrespective of the load. In the basic setting range 0-FN, a frequency correction  $\Delta F$  which is proportionate to the effective current (15-IW) is added to the actual frequency (12-F).

In the field weakening range, this  $\Delta F$  is further corrected by the factor F/FN. The frequency increase calculated in this way is not, however, displayed in the parameter 12-F.

Slip compensation starts at characteristic  $VB \cdot FN$ . It increases in linear fashion from 0% at frequency  $VB \cdot FN$ , to 100% at frequency  $2 \cdot VB \cdot FN$ . Beyond that it is 100%. See Figure B, Page 6-10.

The increase in frequency is only limited by parameter 94-MAXF.

Frequency correction is given by the formula:

In the basic setting range

$$\Delta F = \frac{KSC \cdot IW}{I_{NU}} \cdot FN$$

- IW = 15-IW (effective current)  
 $I_{NU}$  = Inverter rated current  
FN = 43-FN1 (rated frequency)  
KSC = 54-KSC (correction factor)  
F = 12-F (actual frequency)

In the field weakening range

$$\Delta F = \frac{KSC \cdot IW}{I_{NU}} \cdot \frac{F}{FN} \cdot FN$$

### **50-IN Motor rated current [A]**

Motor rated current from motor type plate.

Used in I\*R compensation and slip compensation.

### **51-COS Rated $\cos\phi$ [%]**

$\cos\phi$  from motor type plate (enter as %).

Used in I\*R compensation and slip compensation.

### **52-NN Rated speed [RPM]**

Rated speed from motor type plate.

Used in I\*R compensation and slip compensation.

### 53-KIXR I\*R compensation, correction factor

The KIXR correction factor corresponds to the resistance measured between the two motor leads.

The correction factor can either be entered, or measured from the inverter.

Measurement starts when 48-IXR = 1 and 53-KIXR = 0.

The inverter then produces a maximum 1/16th of the device rate voltage for approximately two seconds or allows a current of maximum 50-IN (entered rated current of motor) to flow. The measured value is automatically stored under 53-KIXR.

#### Warning:

During this measurement, the motor shaft may turn slowly.



### 54-KSC Slip compensation, correction factor [%]

The correction factor 54-KSC is scaled like the motor rated slip to the device rated current.

$$KSC = \left( \frac{n_{SYN} - n_N}{n_{SYN}} \cdot \frac{I_{UN}}{I_N \cdot \cos \varphi} \right) 100 [\%]$$

$n_{SYN}$  = Synchronous speed  
 $n_N$  = 52-NN (motor rated speed)  
 $I_{UN}$  = Inverter rated current  
 $I_N$  = 50-IN (motor rated current)  
 $\cos \varphi$  = 51-COS (cos  $\varphi$ )

The correction factor can either be entered or calculated by the inverter. Calculation starts when 49-SC = 1 and 54-KSC = 0. The synchronous speed for the calculation is determined from the rated frequency 43-FN1. The calculated value is automatically stored under 54-KSC.

### 55-ISEL Current regulation selector [decimal]

The current regulation selector determines the type of current limit value regulation. The control value is the phase apparent current 14-IS.

| 55-ISEL | Function  |
|---------|---|
| 0       | Current limit value control is not active   |
| 1       | Acceleration/braking ramp current-carrying, return to ramp function at $I > 125\% ILIM$ |
| 2       | Acceleration/braking ramp current-carrying, ramp stop at $I > 125\% ILIM$               |



### 56-ILIM Current limit value [A]

See 55-ISEL and diagram.

### 57-FILIM Reduction frequency for current control [Hz]

See 55-ISEL and diagram.

### 58-RILIM Ramp for current regulation [Hz/s]

See 55-ISEL and diagram. The general rule for setting this parameter is: enter 4 x value from 32\_RACC1.

### 59-TRIP I\*t monitoring of motor and triggering current [A]

Parameter 59-ITRIP sets the I\*t trigger current. When this current is exceeded, switch-off occurs after a pre-set triggering time (see diagram) with error message E\_OLM.

#### Motor protection

The setting of the I\*t triggering current must correspond with the rated current of the motor. This ensures that motors of a lower power than the rated equipment are also adequately protected against overload.

Quite apart from parameter 59-ITRIP, the inverter has an I\*t monitor (device) which corresponds to a 59-ITRIP setting = device rated current and switches off with the error message E\_OLI.

Diagram:

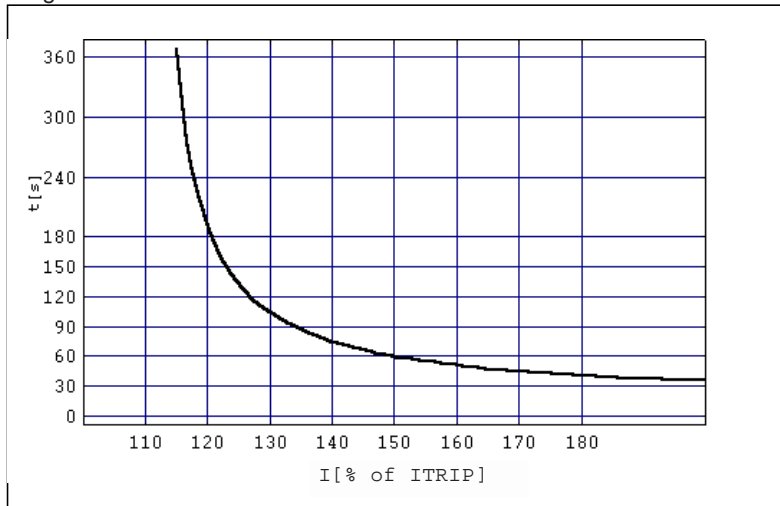

#### Factory setting:

59-TRIP =  $I_N$  phase current (100%) of inverter

## 6.7 Signal outputs

### 61-SOUTA analog output

| SOUTA | meaning                                 | explanation/scaling   |
|-------|---|---|
| 0     | no function                             | SOUTA output = 0  |
| 1     | frequency output                        | 0Hz = 0 V , FMAX = 10 V* 0Hz = 0%PWM,<br>FMAX = 100% PWM**  |
| 2     | braking chopper                         | If the ZK voltage exceeds a fixed value, the SOUTA output becomes active (HIGH). This function is only active if the inverter has started. Output frequency < 1 kHz |
| 3     | pulse signal with pulse duty factor 1:1 | 6-times output frequency in the range(5.1...260Hz) where 12-F < 5 Hz SOUTA = 32 Hz<br>where 12-F > 260 Hz SOUTA =1560 Hz  |
| 4     | apparent current                        | $10 \text{ V}^*/100\% \text{ PWM}^{**} = 200\%$ rated inverter current  |
| 5     | effective current                       | $10 \text{ V}^*/100\% \text{ PWM}^{**} = 100\%$ rated inverter current  |
| 6     | effective power                         | $10 \text{ V}^*/100\% \text{ PWM}^{**} = 100\%$ equipment continuous performance  |
| 7     | SOUTA für SIO                           | possible with RS485 interface option.   |

See jumper strip X2/J3 and J4 and 69-KOUTA = 100%

\* Jumper B, \*\* Jumper C (Chap. 2.4.5)

### 62-S1OUT programmable control output S1OUT [decimal]

### 63-S2OUT programmable control output S2OUT [decimal]

| 62-S1OUT<br>63-S2OUT | Function   |
|----------------------|--|
| 0                    | No function, output S-OUT = 0  |
| 1                    | Active as soon as the inverter is connected to the main power supply and there are no errors |
| 2                    | Active as long as the motor is excited   |
| 3                    | Active as long as anti-clockwise > 0 or DC-hold active                                       |
| 4                    | Active as long as clockwise > 0 or DC-hold active  |
| 5                    | Active as long as rotating field frequency 12-F = 0 Hz                                       |
| 6                    | Active as long as reference value is achieved  |
| 7                    | Active when rotating field frequency 12-F > 25-FF5   |
| 8                    | Active when apparent current 14-IS > 110% 59-TRIP, current limit reached                     |
| 10                   | Active, after fault-clearing   |

**Factory setting:** 62-S1OUT ->1, 63-S2OUT -> 7

### 64-SINA Programmable analog input [decimal]

With this parameter, the internal P1 potentiometer can be allocated three different settings.

| SINA | Function                       | Explanation  |
|------|--------------------------------|--|
| 0    | reference value selection      | left stop = 0Hz right stop = FMAX<br>(where 04-FSSEL=0) factory setting                  |
| 1    | reduction in maximum frequency | left stop = 70% of FMAX<br>right stop = 100% of FMAX                                     |
| 2    | ILIM selection                 | left stop = 30% of inverter rated current<br>right stop = 150% of inverter rated current |

## 6.8 Program functions

### 67-FST Filter time constants [decimal]

This determines the filter time constants for analog FSIN reference value input.

(See also 04-FSSEL), temporal characteristics as PT1 element (low pass).

| 67-FST | Function |
|--------|----------|
| 0      | 0 ms     |
| 1      | 8.2 ms   |
| 2      | 24.6 ms  |
| 3      | 57.4 ms  |
| 4      | 123 ms   |

### 69-KOUTA Factor for analog output 61-SOUTA [decimal]

This parameter is used for scaling the analog SOUTA output.

The voltage of an analog signal output is multiplied by the factor 69-KOUTA and limited to 10 V in accordance with programming of 61-SOUTA.

On output of a PWM signal, the pulse duty factor output is multiplied by the factor 69-KOUTA and limited to 100% in accordance with the 61-SOUTA programming.

### 71-PROG Special programs [decimal]

The parameter 71-PROG is used for activating special programs. Special programs currently available:

| 71-PROG | Function  |
|---------|---|
| 0       | No special program active   |
| 1       | Reset to factory setting (Europe)<br>(after running 71-PROG = 0)  |
| 2       | Changed allocation of control terminals<br>STR = 0 -> clockwise, STL = 1 -> START<br>STR = 1 -> anti-clockwise, STL = 0 -> STOP |
| 3       | Changed allocation of control terminals<br>STR, S1IND, S2IND and ramp factor  |
| 4       | Reset to factory setting (USA)<br>(after running 71-PROG = 0)   |

## 72-STRT Start options [decimal]

| 72-STRT | Function   |
|---------|--|
| 0       | No start option active, factory setting                        |
| 1       | Auto start after power-on with STL or STR bridged              |
| 2       | Synchronisation to running motor                               |
| 3       | Auto start and synchronisation                                 |
| 4       | Block of direction of rotation: blocked anti-clockwise         |
| 5       | Block of direction of rotation and auto start                  |
| 6       | Block of direction of rotation and synchronisation             |
| 7       | Auto start, synchronisation and block of direction of rotation |

### Auto start 72-STRT = 1

If one of the STL or STR start contacts is bridged and the FSIN reference value input > 0.5 Hz, the inverter starts automatically when the mains supply is restored.

### Synchronisation 72-STRT = 2

After activating the start contact, the inverter first searches for the current motor speed. It starts by searching for maximum frequency 22-FMAX1 which means that the inverter is running faster than synchronisation speed. This causes a positive effective current to flow. The rotating field frequency is reduced until the effective current becomes negative so that the inverter is running at below synchronised speed. In this way, the inverter synchronises to the motor speed found with the appropriate rotating field frequency.

Synchronisation functions in both directions of rotation.

### Block of direction of rotation 72-STRT = 4

This start option blocks anti-clockwise rotation of the inverter completely. In this case, anti-clockwise rotation can neither be activated using STL control input nor from the CTRL menu.

## 74-PWM Switching frequency [decimal]

Parameter 74-PWM determines the switching frequency of the final stages.

| 74-PWM | switching frequency | suitable for       | factory setting |
|--------|---------------------|--------------------|-----------------|
| 0      | 7.8 kHz             | VF1104S to VF1402S | all VF1000S     |
| 1      | 15.6 kHz            | VF1104S to VF1204S |                 |
| 2      | 3.9 kHz             | VF1104S to VF1402S |                 |



**75-OPT1 Option 1**

This parameter is for special functions i.e. error resetting.

**Note:** Editing only in 01-MODE = 3 possible.

| 75-OPT1 | Function                     |
|---------|------------------------------|
| 0 0 H   | disabled                     |
| 0 2 H   | resetting through S2IND      |
| 0 4 H   | resetting through STL or STR |

**86-KG Scaling factor for 10-G**

This factor determines the value of the display parameter 10-G in accordance with the formula:

$$(10-G) = (12-F) * (86-KG)$$

**87-DISP Continuous display [decimal]**

87-DISP determines the parameter for continuous display. All parameters on the 'VAL' menu are possible.

**88-PSW1 Password 1 [decimal]**

Determines the password for parametering <PARA> menu.

**89-PSW2 Password 2 [decimal]**

89-PSW2 determines the password for control from the KEYPAD <CTRL> menu.

**91-TYPE Inverter type [decimal]**

91-TYPE represents the type for the recognised power stage. All min/max values and factory settings of voltage and current values which are given in absolute terms depend on this parameter.

**92-REV Software revision [decimal]**

Gives the version of the equipped software.

### 94-MAXF Maximum output frequency [Hz]

The parameter setting determines the limit for the output frequency supplied by the inverter disregarding the choice of referencing or regulation type selected. When 94-MAXF = 0 (default) this limit is equal to setting of 22-FMAX1 for scaling the analogue input.

### 95-ERR1 Error 1 [decimal-0,1s]

Memory for last fault message.

#### Explanation:

*Error No. - Error time*

refer below table

0,1 h = 6 Min. / max. 1,5 h  
reset after error acceptance

Error messages:

| No.    | Explanation  |
|--------|--|
| 1-time | Error in processor                                       |
| 2-time | Undervoltage (no entry in 95-ERR1 ÷ 98-ERR4)             |
| 3-time | Overcurrent/short circuit after power-on short-to-ground |
| 4-time | Overvoltage  |
| 5-time | Ixt motor  |
| 6-time | Ixt inverter   |
| 7-time | Overtemperature motor                                    |
| 8-time | Overtemperature inverter                                 |
| 9-time | Error in EEPROM  |

*Error acceptance through pushing start/enter button for min. 3 sec or digital pulse as per description 75-OPT1.*

