

# Bredel 10, Bredel 15 and Bredel 20 hose pumps

# Bredel

SERIES  
Bredel Hose Pumps

## FEATURES AND BENEFITS

- Sealless, valveless pumping principle for reliable, low maintenance metering, dosing and transfer
- Flow rates up to 820 L/hr (3.6 USGPM) and pressures up to 12bar (174 psi)
- Dry running and self-priming, with up to 9.5 meters (30 foot) suction lift capability
- Robust design for aggressive chemicals or abrasives
- Compact direct coupled design to maximise gearbox life
- Simple hose change decreases cost of ownership, downtime and need for parts inventory



## PERFORMANCE

### Bredel 10

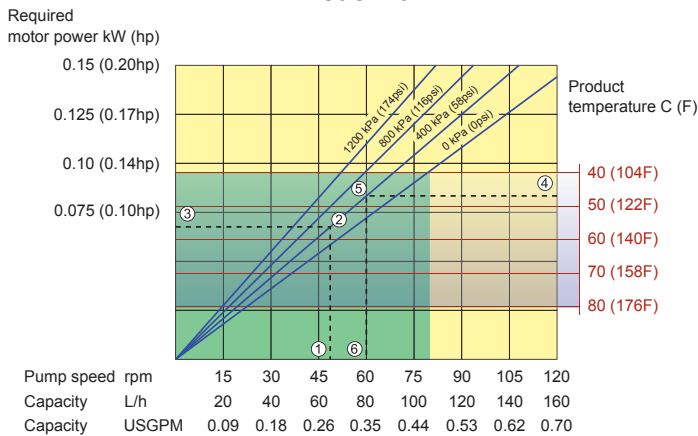

### Bredel 15

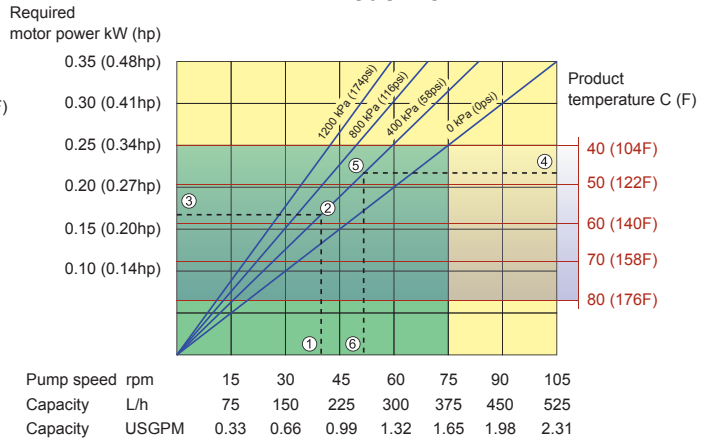

### Bredel 20

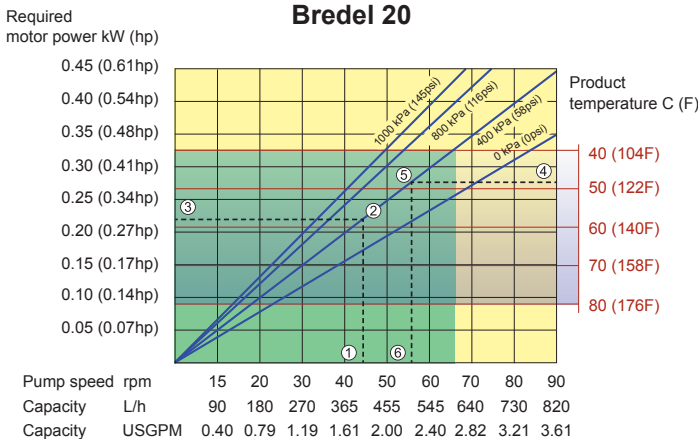

- Continuous Duty
- Intermittent Duty\*

\* Maximum 2 hours operation followed by minimum 1 hour stop

1. Flow required indicates pump speed
2. Calculated discharge pressure
3. Net motor power required
4. Product temperature
5. Calculated discharge pressure
6. Maximum recommended pump speed

Note: The area of continuous operation diminishes with increased product temperatures. For product temperatures >40C, the area of continuous operation reduces to the corresponding red temperature line.

## DIMENSIONS

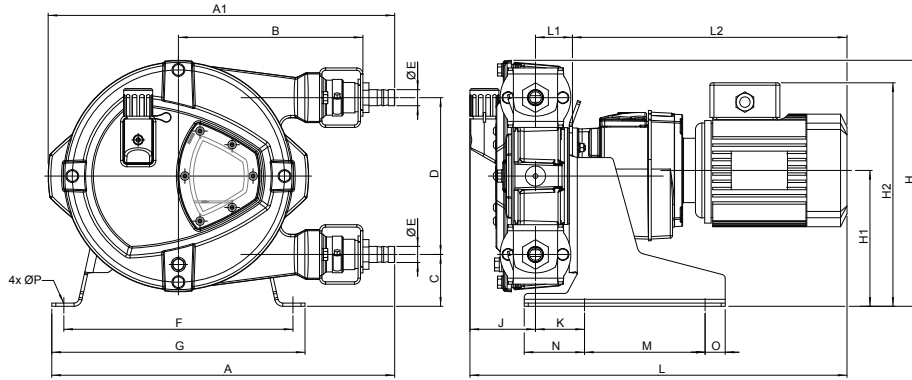

Connector sizes	MNPT	EN DIN	JIS
Bredel 10	0.5"	10mm	10mm
Bredel 15	0.75"	20mm	20mm
Bredel 20	0.75"	20mm	20mm

Type	A	A1	B	C	D	ØE	F	G	H	H1	H2max	J	K	Lmax	L1	L2max	M	N	O	ØP
Bredel 10 (mm)	337	311	171	62	116	16	235	265	225	127	254	78	51	501	46	378	150	65	25	12
Bredel 10 (inches)	13.3	12.2	6.7	2.44	4.6	16mm	9.3	10.4	8.9	5.0	10.0	3.1	2	19.7	1.8	14.9	5.9	2.6	1.0	12mm
Bredel 15 (mm)	427	431	230	63	195	20	285	315	304	167	294	82	61	505	46	378	150	75	25	12
Bredel 15 (inches)	16.8	17.0	9.1	2.5	7.7	20mm	11.2	12.4	12.0	6.6	11.6	3.2	2.4	19.9	1.8	14.9	5.9	3.0	1.0	12mm
Bredel 20 (mm)	427	431	230	63	195	20/25.5*	285	315	304	167	294	82	61	505	46	378	150	75	25	12
Bredel 20 (inches)	16.8	17.0	9.1	2.5	7.7	20mm/25.5mm*	11.2	12.4	12.0	6.6	11.6	3.2	2.4	19.9	1.8	14.9	5.9	3.0	1.0	12mm

\*20mm is for materials PTFE and PVDF. 25.5mm is for material AISI 316.

## TECHNICAL SPECIFICATIONS

	Bredel 10	Bredel 15	Bredel 20
Operating speeds	up to 82rpm continuous up to 110rpm intermittent	up to 75rpm continuous up to 110rpm intermittent	up to 67rpm continuous up to 90rpm intermittent
Flow range	up to 145 L/hr (0.63 USGPM)	up to 525 L/hr (2.32 USGPM)	up to 820 L/hr (3.62 USGPM)
Capacity	0.022 L/rev (0.006 G/rev)	0.083 L/rev (0.022 G/rev)	0.152 L/rev (0.040 G/rev)
Minimum starting torque	47Nm (416 inch-lbs)	60Nm (531 inch-lbs)	85Nm (752 inch-lbs)
Hose lubricant required	0.25 litres (0.07 USG)	0.5 litres (0.1 USG)	0.5 litres (0.1 USG)
Pumphead weight	12.2kg (26.89lbs)	18.5kg (40.79lbs)	18.5kg (40.79lbs)
Max discharge pressure NR, NBR, F-NBR	12bar (174psi)	12bar (174psi)	10bar (145psi)
Max discharge pressure EPDM, CSM	10bar (145psi)	10bar (145psi)	10bar (145psi)
<b>Common features</b>			
Suction pressure	9.5m (31.2ft) lift to 200 kPa (2bar) (29psi)		
Product temperature range	-10C up to 80C (14F up to 176F)		
Ambient temperature range*	-20C up to 45C (-4F up to 113F)		

\*Allowable ambient temperature is based on pump capabilities and may be further limited by gearbox ambient capabilities

## MATERIALS OF CONSTRUCTION

	Bredel 10	Bredel 15	Bredel 20
Pump housing		Cast iron	
Rotor with integral shoes		Cast iron	
Cover		Cast iron	
Brackets		AISI 316	
Support frame		Galvanised steel or AISI 316	
Fasteners		AISI 316	
Hose clamps		AISI 316	
Coupling bush		Alloy steel	
Seals		EPDM	

Options	Bredel 10/15/20
Available hose materials	NR Endurance, NBR, EPDM, CSM, NBR for food, F-NBR
Available rotors	Low pressure (0-4bar / 0-58 psi) Medium pressure (0-8bar / 0-115 psi) High pressure (0-12bar / 0-174 psi)
Available port configurations	Ports left (position 1), right (position 2), up (position 3) and down (position 4). Standard configuration position 2
Integrated FI for stand alone speed control	Factory programmable from 12-80 Hz
Revolution counter	For maintenance and /or metering
High level float switch	Max. 2A, 230 V AC/DC, max. 40VA ATEX: max. 50 mA, max. 28V AC/DC
<b>Insert combinations</b>	
Hose nipple	AISI 316, PTFE, PVDF
Threaded nipple	AISI 316 BSP, AISI 316 NPT, PP NPT, PVC NPT, AISI 316 DIN 11851
Threaded nipple and flange (+nut) assembly	AISI 316 BSP nipple and Flange DIN threaded AISI 316, AISI 316 BSP nipple and Flange ASA threaded AISI 316
Flange and bracket assembly	Flange DIN AISI 316 + PP insert, Flange ASA AISI 316 + PP insert, Flange DIN AISI 316 + AISI 316 insert, Flange ASA AISI 316 + AISI 316 insert

The information contained in this document is believed to be correct at the time of publication, but Watson-Marlow BredeL BV accepts no liability for any error it contains, and reserves the right to alter specifications without prior notice. All mentioned values in this document are values under controlled circumstances at our test bed. Actual flow rates achieved may vary because of changes in temperature, viscosity, inlet and discharge pressures and/or system configuration. APEX, DuCoNite®, Bioprene® and BredeL are registered trademarks.

**Bredel**  
Hose Pumps

wmftg.com  
+44 (0)1326 370 370  
info@wmftg.com