

**Solutions for Fluid Technology**

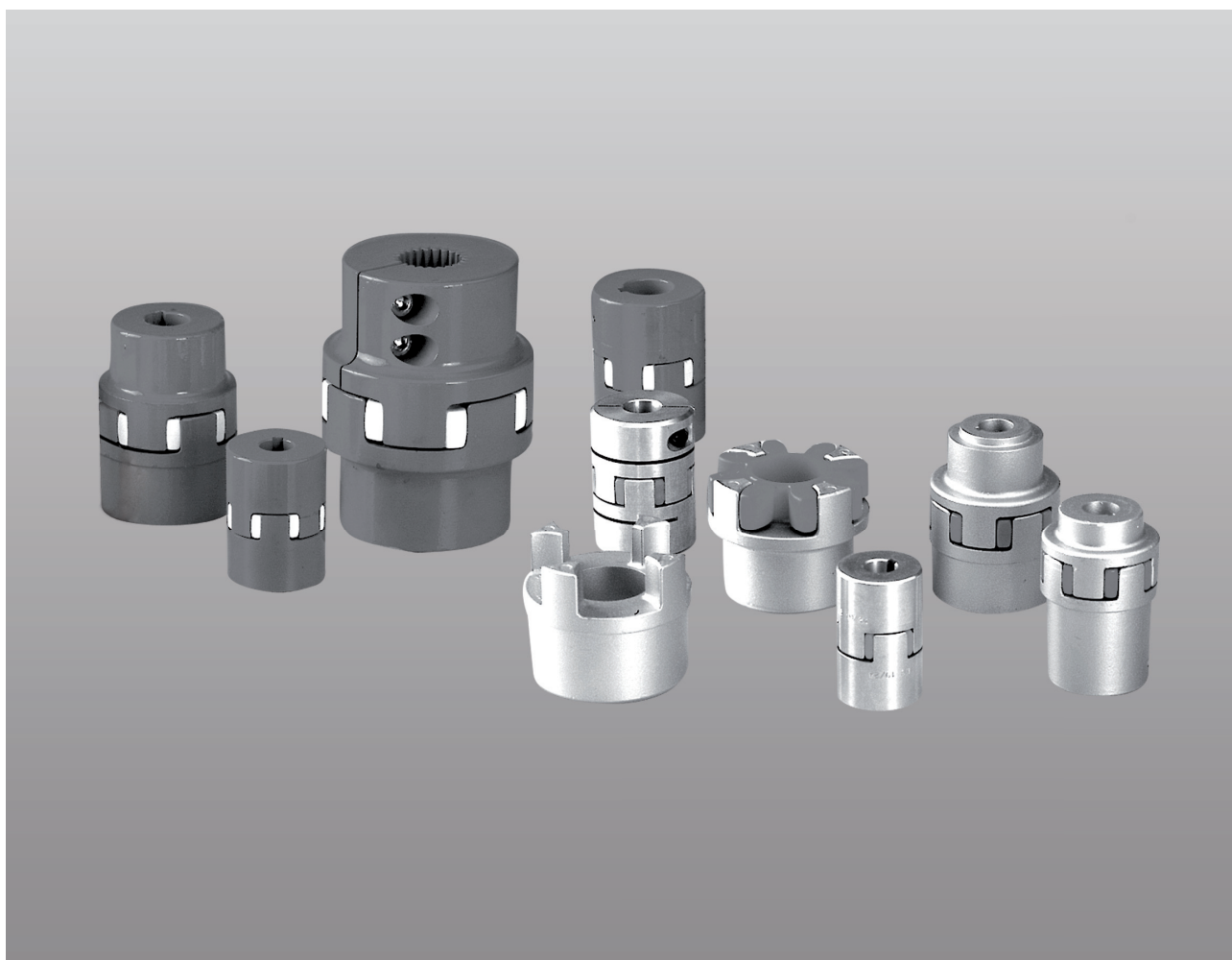

**SOFTEX® ELASTISCHE UND DREHSPIELFREIE WELLENKUPPLUNGEN**

**SOFTEX® ELASTIC AND NO BACKLASH SHAFT COUPLINGS**

## SOFTEX® ELASTISCHE KUPPLUNGEN

### SOFTEX®-STANDARD KUPPLUNGEN SOFTEX®-STANDARD COUPLINGS

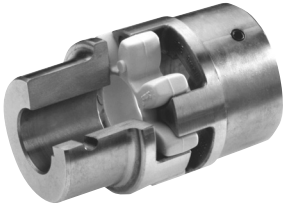

- Drehelastisch, wartungsfrei
- Schwingungsdämpfend
- Axial steckbar
- Allseitig bearbeitet – gute dynamische Eigenschaften
- Kompakt bauend/niedrige Schwungmomente
- Lieferbare Materialien der Naben: Aluminium, Grauguss (EN-GJL-250), Sphäroguss (EN-GJS-400-15), Sinterstahl und Stahl
- Verschiedene Elastomerhärten der Zahnkränze
- Bohrungsdurchmesser zylindrisch (metrisch / Zoll), konisch oder verzahnt nach DIN oder SAE-Norm lieferbar
- **Atex-Zulassung**
- Torsionally flexible, maintenance-free
- Vibration reducing
- Axially pluggable
- Machined all over – good dynamic properties
- Compact design/low flywheel effects
- Available hub materials: Aluminium, cast iron (EN-GJL-250), spheroidal cast iron (EN-GJS-400-15), sintered steel and steel
- Different elastomer hardness of the gear rings
- Bore diameter cylindrical (metric/inch), available tapered or splined acc. to DIN SAE standard
- **Atex approval**

### SOFTEX®-TL MIT TAPER-KLEMMBUCHSE SOFTEX®-TL WITH TAPER BUSH



- Für alle Antriebsfälle im Bereich des Maschinenbaues
- Reibschlüssige, lösbare Wellen/Nabenverbindungen
- Kupplungskombination TL 1/1; TL 2/2 und TL 1/2 möglich
- Kupplungsnaben TL 2 axial trennbar
- Einsetzbar mit allen Standard Taper-Klemmbuchsen
- For all driving applications concerning mechanical engineering
- Friction-locked solvable shafts/hub connections
- Coupling types TL 1/1; TL 2/2 and TL 1/2 possible
- Coupling hubs TL 2 axially separable
- Application with all standard taper bushes

## SOFTEX® ELASTIC COUPLINGS

### SOFTEX®-FA FLANSCHKUPPLUNGEN SOFTEX®-FA FLANGE COUPLINGS

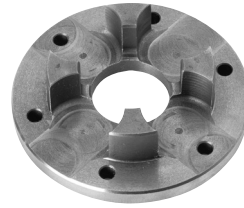

- Flanschnaben für den Schwermaschinenbau
- Alle Größen sind flanschseitig unbearbeitet und montagefertig bearbeitet lieferbar
- 2-Flansche kombinierbar oder FA Flansch mit Standard Softex®-Nabe
- Werkstoff: Grauguss (EN-GJL-250)
- Flange hubs for heavy machinery
- All sizes are unmachined on the flange side and available ready for assembly
- 2 flanges can be combined or FA flange with standard Softex® hub
- Material: Cast Iron (EN-GJL-250)

### SOFTEX®-ES SPIELFREIE KUPPLUNGEN SOFTEX®-ES NO BACKLASH COUPLINGS



- Unter Vorspannung spielfreie Wellenverbindung
- Werkstoff: Naben Aluminium
- Verschiedene Elastomerhärten der Zahnkränze
- 3-teilige einfachkardanische Kupplung
- Axial steckbar – einfache Blindmontage, keine zeitaufwändigen Verschraubungen
- Kleine Baumaße – geringe Schwungmomente
- Wartungsfrei
- Einfache optische Prüfung
- Lieferbar für alle üblichen Wellenabmessungen
- Fertigbohrungen nach ISO-Passung H7, (Klemmnabe F7), Passfedernute ab  $\varnothing 6$  nach DIN 6885 Bl. 1-JS9
- Under initial tension no backlash shaft connection
- Material: Hubs made of aluminium
- Different elastomer hardness of the gear rings
- Triple simple cardanic coupling
- Axially pluggable – simple blind mounting, no time-consuming screwings
- Small structural dimensions – low flywheel effects
- Maintenance-free
- Simple optical test
- Available for all usual shaft dimensions
- Finish bores acc. to ISO limit and fit H7 (clamp hub F7) keyway from  $\varnothing 6$  acc. to DIN 6885 P.1-JS9

**SOFTEX® STANDARD KUPPLUNGEN  
(DREHELASTISCHE KUPPLUNGEN)**

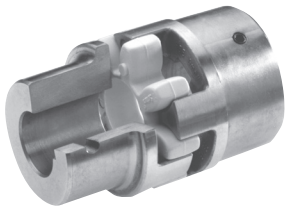

**PRODUKTBESCHREIBUNG**

- Drehelastisch, wartungsfrei
- Schwingungsdämpfend
- Axial steckbar
- Allseitig bearbeitet – gute dynamische Eigenschaften
- Kompakt bauend/niedrige Schwungmomente

**SOFTEX® STANDARD COUPLINGS  
(ELASTIC COUPLINGS)**

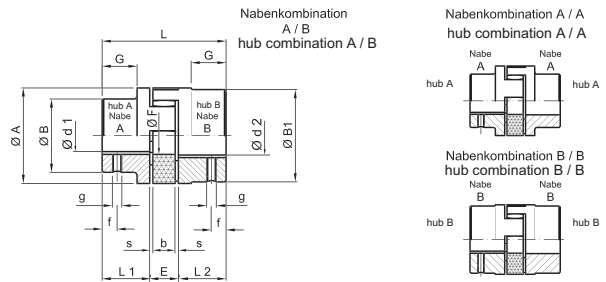

**PRODUCT DESCRIPTION**

- Torsionally flexible, maintenance-free
- Vibration reducing
- Axially pluggable
- Machined all over – good dynamic properties
- Compact design/ low flywheel effects

**WERKSTOFF: ALUMINIUM- DRUCKGUSS**

**MATERIAL: DIE CAST ALUMINIUM**

TYP SIZE	NABE A / HUB A		NABE A / HUB B		ABMESSUNGEN / DIMENSIONS mm													L <sub>1</sub> VERLÄNGERTE B-NABEN EXTENDED B-HUBS max. mm	GEWICHT <sup>2</sup> WEIGHT kg KOMBINATION A/B COMBINATION A/B	
	VORBOHRUNG PREBORE d1	FERTIGBOHRUNG <sup>1)</sup> FINISH BORE d1	VORBOHRUNG PREBORE d2	FERTIGBOHRUNG <sup>1)</sup> FINISH BORE d2	A	B	B <sub>1</sub>	L	L <sub>1</sub> + L <sub>2</sub>	E	s	b	G	F	g	f				
19/24 Aluminium	6	6	19	18	20	24	40	31	38	66	25	16	2	12	20	18	M5	10	-	0,11
24/30 Aluminium	6	8	24	22	25	30	55	39	48	78	30	18	2	14	24	27	M5	10	50	0,24
28/38 Aluminium	9	10	28	26	30	38	65	46	61	90	35	20	2,5	15	28	30	M6	15	60	0,42
38/45 Aluminium	12	14	38	36	40	45	80	64	75	114	45	24	3	18	37	38	M8	15	-	0,86

**WERKSTOFF: GG = GUSSEISEN (DIN EN 1561/1563)  
S = SINTERSTAHL ST = STAHL**

**MATERIAL: GG = CAST IRON (DIN EN 1561/1563)  
S = SINTERED STEEL ST = STEEL**

TYP SIZE	NABE A / HUB A		NABE A / HUB B		ABMESSUNGEN / DIMENSIONS mm													L <sub>1</sub> VERLÄNGERTE B-NABEN EXTENDED B-HUBS max. mm	GEWICHT <sup>2</sup> WEIGHT kg KOMBINATION A/B COMBINATION A/B	
	VORBOHRUNG PREBORE d1	FERTIGBOHRUNG <sup>1)</sup> FINISH BORE d1	VORBOHRUNG PREBORE d2	FERTIGBOHRUNG <sup>1)</sup> FINISH BORE d2	A	B	B <sub>1</sub>	L	L <sub>1</sub> + L <sub>2</sub>	E	s	b	G	F	g	f				
14/16 S	-	-	-	4	16	30	-	30	35	11	13	1,5	10	-	8	M4	5	-	0,14	
19/24 S	-	-	-	6	24	40	-	40	66	25	16	2	12	-	18	M5	10	40	0,34	
24/30 S	-	-	-	8	32	55	-	55	78	30	18	2	14	-	27	M5	10	50	0,90	
28/38 S	-	-	-	10	38	65	-	65	90	35	20	2,5	15	-	30	M6	15	60	1,5	
38/45 GG	-	14	38	-	40	45	80	66	78	114	45	24	3	18	37	38	M8	15	70	2,35
42/55 GG	-	16	42	-	45	55	95	75	93	126	50	26	3	20	40	46	M8	20	75	3,55
48/60 GG	-	19	48	-	50	60	105	85	103	140	56	28	3,5	21	45	51	M8	20	80	4,85
55/70 GG	-	22	55	53	60	70	120	98	118	160	65	30	4	22	52	60	M10	20	90	7,4
65/75 GG	-	25	65	60	70	75	135	115	133	185	75	35	4,5	26	61	68	M10	20	100	10,8
75/90 GG	-	30	75	73	80	90	160	135	158	210	85	40	5	30	69	80	M10	25	110	17,7
90/100 GG	-	-	-	-	45	100	200	-	170	245	100	45	5,5	34	81	100	M10	25	-	29,6
100/110 ST	-	-	-	-	45	110	225	-	180	270	110	50	6	38	89	113	M12	30	-	39,0
110/125 ST	-	-	-	-	60	125	255	-	200	295	120	55	6,5	42	96	127	M16	35	-	55,0

1) Fertigbohrungen nach ISO- Passung H 7, Passfedernut nach DIN 6885, Blatt 1- JS9, konische Bohrungen siehe Seite 6.  
2) Gewichte beziehen sich auf die Werkstoffe Aluminium/ GG bei max d<sub>1</sub> ohne Nut.

1) Finish bores acc. to ISO- standard H 7, keyway acc. to DIN 6885, sheet 1- JS9, taper bores page 6.  
2) Weights refer to materials aluminium/ GG with d<sub>1</sub> max. without keyway.

## SOFTEX®-FA DREHELASTISCHE FLANSCHKUPPLUNGEN

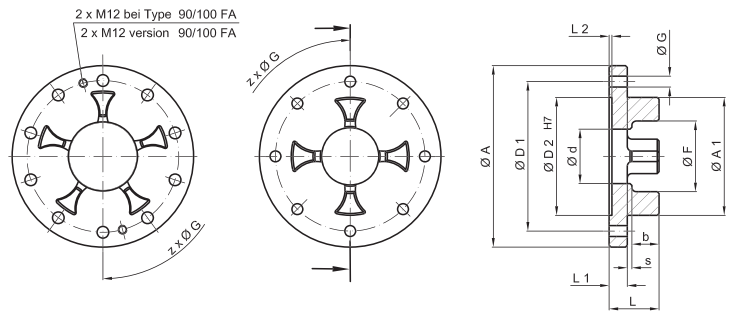
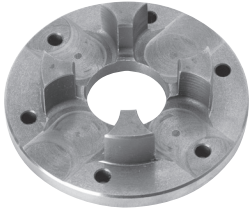

### PRODUKTBESCHREIBUNG

- Flanschnaben für den Schwermaschinenbau
- Alle Größen sind flanschseitig unbearbeitet und montagefertig bearbeitet lieferbar
- 2-Flansche kombinierbar oder FA Flansch mit Standard SOFTEX®-Nabe
- Werkstoff: Grauguss (EN- GJL-250)

### PRODUCT DESCRIPTION

- Flange hubs for heavy machinery
- All sizes are unmachined on the flange side and available ready for assembly
- 2 flanges can be combined or FA flange with standard SOFTEX® hub
- Material: Cast Iron (EN-GJL-250)

TYP SIZE	ABMESSUNGEN DIMENSIONS mm													
	A	A <sub>1</sub>	L	L <sub>1</sub>	s	b	F	I <sub>2</sub>	D <sub>1</sub>	D <sub>2</sub>	d	G	Z ANZAHL QUANTITY	GEWICHT <sup>1)</sup> WEIGHT <sup>1)</sup> kg
28/38 FA	100	65	27,5	10	2,5	15	39	1,5	80	65	30	7	6	0,55
38/45 FA	115	80	31	10	3	18	48	1,5	95	80	38	7	6	0,75
42/55 FA	140	95	35	12	3	20	57	2	115	95	46	9	6	1,35
48/60 FA	150	105	36,5	12	3,5	21	63	2	125	105	51	9	8	1,55
55/70 FA	175	120	42	16	4	22	74	2	145	120	60	11	8	2,70
65/75 FA	190	135	46,5	16	4,5	26	83	2	160	135	68	11	10	3,30
75/90 FA	215	160	54	19	5	30	98	2,5	185	160	80	14	10	4,90
90/100 FA	260	200	59,5	20	5,5	34	122	3	225	200	100	14	12	6,70

1) Gewichte beziehen sich auf den Werkstoff GG.

1) Weights refer to material GG.

### FLANSCHNABEN

Kombinierbare Standardnaben entnehmen Sie bitte der Tabelle auf Seite 3 und alle technischen Daten von Seite 6 und 7. Alle Größen sind auch unbearbeitet ohne die Maße D1-D2-12-G lieferbar.

### FLANGE HUBS

Please consult the table on page 3 for combinable standard hubs and pages 6 and 7 for all technical data. All sizes also available unmachined without dimensions D1-D2-12-G.

# SOFTEX®-TL DREHELASTISCHE KUPPLUNGEN MIT TAPER-KLEMMBUCHSE

# SOFTEX®-TL ELASTIC COUPLINGS WITH TAPER BUSH

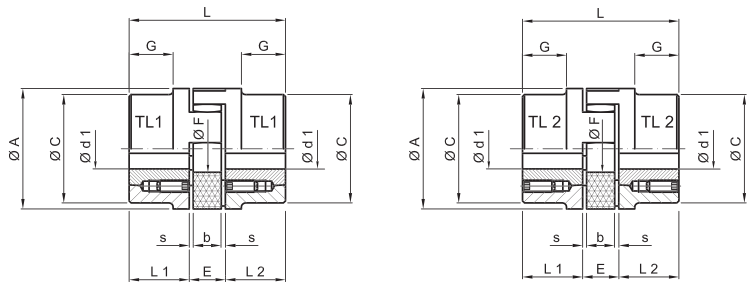

## PRODUKTBESCHREIBUNG

- Für alle Antriebsfälle im Bereich des Maschinenbaus
- Reibschlüssige, lösbare Wellen/Nabenverbindungen
- Kupplungskombination TL 1/1; TL 2/2 und TL 1/2 möglich
- Kupplungsnaben TL 2 axial trennbar
- Einsetzbar mit allen Standard Taper-Klembuchsen
- Material: Kupplungsnaben Grauguss (EN-GJL-250), Klembuchse Stahl

## PRODUCT DESCRIPTION

- For all driving applications concerning mechanical engineering
- Friction-locked solvable shafts/hub connections
- Coupling types TL 1/1; TL 2/2 and TL 1/2 possible
- Application with all standard taper bushes
- Material: Coupling hub cast iron (EN-GJL-250), taper bush steel

TYP SIZE	KLEMM- BUCHSE TAPER- BUSH	ABMESSUNGEN DIMENSIONS mm									GEWICHT BEI MAX. BOHR-Ø WEIGHT AT MAX. BORE Ø kg	MASSENTRÄGHEITS- MOMENT J BEI MAX. BOHR-Ø ANGULAR MOMEN- TUM AT MAX. BORE Ø kg m <sup>2</sup>	BEFESTIGUNGSSCHRAUBEN FÜR TAPER-BUCHSE FIXING SCREW FOR TAPER-BUSH			
		A	C	L	L <sub>1</sub> L <sub>2</sub>	E	s	b	G	F			GRÖSSE SIZE ZOLL	LÄNGE LENGTH mm	AN- ZAHL QUANT.	ANZ.-MT TORQUE Nm
28/38	1108	65	65	66	23	20	2,5	15	-	30	1,0	0,0007	1/4"	13	2	5,6
38/45	1108	80	78	70	23	24	3	18	15	38	2,7	0,0030	1/4"	13	2	5,6
42/55	1610	95	93	78	26	26	3	20	16	46	3,0	0,0036	3/8"	16	2	20
48/60	1615	105	103	106	39	28	3,5	21	28	51	4,8	0,0080	3/8"	16	2	20
55/70	2012	120	118	96	33	30	4	22	20	60	4,9	0,0120	7/16"	22	2	31
65/75	2012	135	115	101	33	35	4,5	26	19	68	6,9	0,0140	7/16"	22	2	31
75/90	1) 2517 2) 3020	160	158	144	52	40	5	30	36	80	14,5	0,0650	1/2" 5/8"	25 32	2	50 90

1) nur lieferbar für TL 1 2) nur lieferbar für TL 2

1) only available for TL 1 2) only available for TL 2

TAPER BUCHSEN- GRÖSSE SIZE OF TAPER BUSH	LIEFERBARE BOHRUNGSABMESSUNGEN d1; PASSUNG H7 – PASSFEDERNUTE NACH DIN 6885 BL. 1*																		
	BORE DIMENSIONS AVAILABLE d1; LIMIT AN FIT H7 – KEYWAY ACC. TO DIN 6885 P.1*																		
1108	9	10	11	12	14	16	18	19	20	22	24	25	28*						
1610	14	16	18	19	20	22	24	25	28	30	32	35	38	40	42*				
1615	14	16	18	19	20	22	24	25	28	30	32	35	38	40	42*				
2012	14	16	18	19	20	22	24	25	28	30	32	35	38	40	42	45	48	50	
2517	16	18	19	20	22	24	25	28	30	32	35	38	40	42	45	48	50	55	60

\*Bohrung mit Passfedernute (flache Ausführung) DIN 6885 Blatt 3

\*Bore with keyway (flat type) acc. to DIN 6885 page 3

## BESTELLBEISPIEL

## ORDER EXAMPLE

KUPPLUNGSGRÖSSE SIZE OF COUPLING	ZAHNKRANZ HÄRTE HARDNESS OF SPIDER SHORE A	NABE HUB	FERTIGBOHRUNG FINISH BORE	NABE HUB	FERTIGBOHRUNG FINISH BORE
SOFTEX® 42/55	92°	TL 1	Ø 28	TL 1	Ø 38

KUPPLUNGSTYPEN FÜR ALLE WERKSTOFFE COUPLING TYPES FOR ALL MATERIALS	DREHMOMENT/TORQUE Nm			DREHMOMENT/TORQUE Nm			DREHMOMENT/TORQUE Nm			DREHMOMENT/TORQUE Nm			MAX. DREHZAHL <sup>1)</sup> SPEED 1/MIN BEI V/AT V	
	ZAHNKRANZ POLYURETHAN POLYURETHANE SPIDER 80° Shore A Farbe/colour: blau/blue			ZAHNKRANZ POLYURETHAN POLYURETHANE SPIDER 92° Shore A Farbe/colour: weiß/white			ZAHNKRANZ POLYURETHAN POLYURETHANE SPIDER 98° Shore A / 95° Shore A Farbe/colour: rot/red			ZAHNKRANZ POLYURETHAN POLYURETHANE SPIDER 64° Shore D Farbe/colour: grün/green				
	NENN CONT. T <sub>KN</sub>	MAX. TK <sub>MAX.</sub>	WECHSEL ALTER- NATING T <sub>KW</sub>	NENN CONT. T <sub>KN</sub>	MAX. TK <sub>MAX.</sub>	WECHSEL ALTER- NATING T <sub>KW</sub>	NENN CONT. T <sub>KN</sub>	MAX. TK <sub>MAX.</sub>	WECHSEL ALTER- NATING T <sub>KW</sub>	NENN CONT. T <sub>KN</sub>	MAX. TK <sub>MAX.</sub>	WECHSEL ALTER- NATING T <sub>KW</sub>		
14/16	4	8	1	7,5	15	2	12,5	25	3,3	-	-	-	19000	-
19/24	4,9	9,7	1,3	10	20	2,6	17	34	4,4	75	150	20	14000	19000
24/30	17	34	4,4	35	70	9	60	120	16	200	400	52	10600	14000
28/38	46	92	12	95	190	25	160	320	42	405	810	105	8500	11800
38/45	93	186	24	190	380	49	325	650	85	560	1120	145	7100	9500
42/55	130	260	34	265	530	69	450	900	120	655	1310	170	6000	8000
48/60	150	300	39	310	620	81	525	1050	137	750	1500	195	5600	7100
55/70	180	360	47	375	750	93	625	1250	163	800	1600	208	4750	6300
65/75	205	410	53	625	850	111	900	1880	169	1830	3660	476	4250	5600
75/90	475	950	124	975	1950	254	1500	3000	390	4500	9000	1170	3550	4750
90/100	1175	2350	306	2400	4800	624	3600	7200	963	-	-	-	2800	3750
100/110	-	-	-	3300	6600	858	4950	9900	1287	-	-	-	2500	3350
110/125	-	-	-	4000	8000	1040	6000	12000	1560	-	-	-	2240	3000
125/145	-	-	-	5000	10000	1300	7500	15000	1950	-	-	-	2000	2650

1) Für Umfangsgeschwindigkeiten über  $V = 30$  m/s sind anstatt GG Naben dyn. ausgewuchtete Naben aus GGG oder Stahl erforderlich.

1) For peripheral speeds exceeding  $V = 30$  m/s dynamically balanced hubs made of GGG or steel instead of GG hubs are required.

## VERLAGERUNGSWERTE

## MISALIGNMENT VALUES

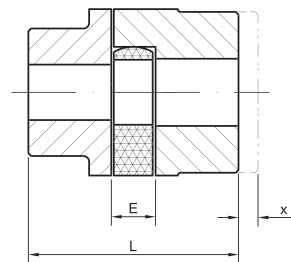

Axialverschiebung  
Axial displacement

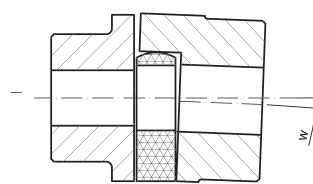

Winkerverschiebung  
Angular displacement

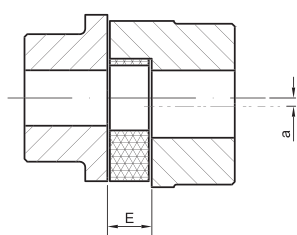

Radialverschiebung  
Radial displacement

TYP SIZE	E	MAX. AXIALVERSCHIEBUNG* MAX. AXIAL DISPLACEMENT* mm x	MAX. WINKELVERLAGERUNG w bei 1500 1/min oder MAX. ANGULAR DISPLACEMENT w 1500 1/min or	MAX. RADIALVERLAGERUNG bei 1500 1/min, mm a MAX. RADIAL DISPLACEMENT 1500 1/min, mm a
14/16	13	1,0	0,9°	0,17
19/24	16	1,2	0,9°	0,2
24/30	18	1,4	0,9°	0,22
28/38	20	1,5	0,9°	0,25
38/45	24	1,8	1°	0,28
42/55	26	2,0	1°	0,32
48/60	28	2,1	1,1°	0,36
55/70	30	2,2	1,1°	0,38
65/75	35	2,6	1,2°	0,42
75/90	40	3,0	1,2°	0,48
90/100	45	3,4	1,2°	0,50
100/110	50	3,8	1,2°	0,52
110/125	55	4,2	1,3°	0,55
125/145	60	4,6	1,3°	0,60

\*Bei Axialverlagerungen dürfen die Maße „E“ und „L“ nur um die angegebenen Werte überschritten werden.

Bei der Kupplungsmontage ist darauf zu achten, dass das E-Maß genau eingehalten wird, damit die Kupplung axial beweglich bleibt. Sorgfältiges Ausrichten der Wellen erhöht die Lebensdauer der Kupplung. Die Verlagerungswerte sind drehzahl- und leistungsabhängig.

\*In case of axial misalignment the factors "E" and "L" are the max. values.

When mounting the coupling, dimension "E" must be observed exactly in order to keep the coupling axially flexible. The stability of the coupling will be increased by careful alignment of the shafts. The displacement values depend on torque speed and performance.

BETRIEBS-ART OPERA-TING TYPE	ARBEITSMASCHINE/BEISPIELE DRIVEN MACHINE/EXAMPLES	TREIBENDE MASCHINE PRIME MOTOR				
		ELEKTRO-MOTOR E-MOTOR	DIESEL-/OTTO-MOTORE (ZYLINDER) DIESEL-/PETROL ENGINES (CYLINDERS)			
			≥4	3	2	1
a	<b>Gleichmäßiger Betrieb und geringe zu beschleunigende Massen</b> Hydraulik- und Kreiselpumpe, Lichtgenerator, Ventilatoren, Transportanlagen <b>Uniform operation, with small masses to be accelerated</b> Hydraulic and centrifugal pumps, light generators, transmissions, ventilators, transfer equipments	1,0 - 1,25	1,2 - 1,5	1,5 - 1,7	1,7 - 2,0	2,4 - 2,7
b	<b>Gleichmäßiger Betrieb und mittlere zu beschleunigende Massen</b> Biegel-, Holzbearbeitungs-, Textil-, Werkzeugmaschinen, Förderbänder, Mischer, Rührwerke <b>Uniform operation, with medium masses to be accelerated</b> Sheet metal banding machines, wood working machines, textile machines, mills, mixers	1,6 - 1,8	1,7 - 2,0	2,0 - 2,3	2,3 - 2,5	2,8 - 3,0
c	<b>Un gleichmäßiger Betrieb und mittlere zu beschleunigende Massen</b> Druckerei, Farbe-, Schleif-, Ringspinn-, Holzbearbeitungsmaschinen, Förderbänder, Generatoren, Kreiselpumpen und Rührwerke für halbflüssiges Gut, Lastaufzüge, Mischer, Reißwölfe, Winden <b>With medium masses to be accelerated and irregular operation</b> Rotating ovens, printing and colouring machines, generators, shredders, winders, spinning machines, pumps for viscous fluids	1,8 - 1,9	2,0 - 2,0	2,3 - 2,5	2,5 - 2,7	2,9 - 3,1
d	<b>Un gleichmäßiger Betrieb, mittlere zu beschleunigende Massen und Stöße</b> Betonmischer, Dreschmaschinen, Gebläse, Hängebahnen, Hobelmaschinen, Kettenbahnen, Krananlagen, Mahlgänge, Mühlen, Personenaufzüge, Plattenbänder, Presspumpen, Rollfässer, Schiffswellen, Seilwinden, Seilfaktoren, Straßenwalzen, Kompressoren, Walzenstühle, Webstühle, Zentrifugen <b>With medium masses to be accelerated, irregular operation and shocks</b> Concrete mixers, drop hammers, cable cars, paper mills, compression and propeller pumps, rope winders, centrifuges	1,8 - 2,0	2,2 - 2,5	2,5 - 2,7	2,7 - 3,0	3,1 - 3,4
e	<b>Un gleichmäßiger Betrieb, große zu beschleunigende Massen und starke Stöße</b> Bagger, Walzgerüste, Drahtzüge, Hammermühlen, Holzschleifer, Kolbenpumpen /kompressoren mit leichtem Schwungrad, Pressen, Rotary-Bohranlagen, Rüttelmaschinen, Scheren, Schmiedepressen, Stanzen <b>Large masses to be accelerated, irregular operation and heavy shocks</b> Excavators, hammer mills, piston pumps, presses, rotary boring machines, shears, forge presses, stamping presses	2,1 - 2,3	2,5 - 2,7	2,7 - 3,0	3,2 - 3,4	3,5 - 3,8
f	<b>Un gleichmäßiger Betrieb, sehr große zu beschleunigende Massen und besonders Stößen</b> Betonmischer, Dreschmaschinen, Gebläse, Hängebahnen, Hobelmaschinen, Kettenbahnen, Krananlagen, Mahlgänge, Mühlen, Personenaufzüge, Plattenbänder, Presspumpen, Rollfässer, Schiffswellen, Seilwinden, Seilfaktoren, Straßenwalzen, Kompressoren, Walzenstühle, Webstühle, Zentrifugen <b>Very large masses to be accelerated, irregular operation and very heavy shocks</b> Piston type compressors and pumps without speed variations, heavy roll sets, welding machines, brick presses, stone crushers	2,5 - 3,1	3,0 - 3,3	3,3 - 3,6	3,7 - 4,0	4,1 - 4,5

SICHERHEITSAKTOR K2 FÜR BETRIEBSDAUER (STD./TAG) SAFETY FACTOR K2 FOR OPERATION PERIOD (HOURS/DAY)				
über more than	-	2	12	
bis up to	2	12	24	
Faktor K2 Factor K2	0,9	1	1,1	

SICHERHEITSAKTOR K3 FÜR SCHALTUNGEN PRO STUNDE SAFETY FACTOR K3 FOR STARTS PER HOUR					
über more than	-	10	40	125	500
bis up to	10	40	125	500	-
Betriebsart a-c Operating type a-c	1	1,05	1,3	1,45	1,6
Betriebsart d-f Operating type d-f	1	1,05	1,1	1,15	1,5

BENENNUNG DESIGNATION	DEFINITION DEFINITION					
ANLAUF-FAKTOR SZ STARTING FACTOR SZ	Faktor zur Berücksichtigung der zusätzlichen Belastung durch die Anfahrhäufigkeit Z je Stunde The factor which takes into account the additional loading caused by the frequency Z of starts per hour	z	100	200	400	800
		Sz	1	1,2	1,4	1,6
TEMPERATUR-FAKTOR ST TEMPERATURE FACTOR ST	Faktor, der das Absinken der Zahnkranzfestigkeit durch Wärmeeinfluss berücksichtigt. Die Temperatur t bezieht sich auf die unmittelbare Umgebung der Kupplung. Bei evtl. Einwirkung von Strahlungswärme ist dies besonders zu beachten The factor which considers the decrease of stability of the elastic rubber material in accordance to the thermal influence	T (° C) T (° C)			St für Polyurethan (OUR) St for Polyurethan (PUR)	
		-25° < +30° < +30° < +40° < +40° < +60° C < +60° C < +60° C < +80° C			1 1,2 1,4 1,6	
STOSS-FAKTOR S <sub>A</sub> /S <sub>L</sub> SHOCK FACTOR S <sub>A</sub> /S <sub>L</sub>	Leichte Anfahrstöße 1,5	Mittlere Anfahrstöße 1,8	Schwere Anfahrstöße 2,2			
	Slight starting shock 1,5	Medium starting shocks 1,8	Heavy starting shocks 2,2			

EINSATZBEDINGUNGEN FÜR SOFTEX®-ZAHNKRÄNZE OPERATING CONDITIONS FOR SOFTEX®-SPIDERS	STANDARDAUSFÜHRUNG (POLYURETHAN) STANDARD SPIDER (POLYURETHANE)			SONDER-ZAHNKRANZ (HYTREL) SPECIAL SPIDER (HYTREL)
ZAHNKRANZHÄRTE UND FARBE HARDNESS OF SPIDER AND COLOUR	80° Shore (A) Blau 80° Shore (A) Blue	92° Shore (A) Weiß 92° Shore (A) White	95°/98° Shore (A) Rot 95°/98° Shore (A) Red	64° Shore (D) Grün 64° Shore (D) Green
ZUL. TEMPREATUREBEREICH DAUER-EINSATZ PERMISSIBLE DURABLE TEMPERATURE RANGE	-50°C bis +80° C -50°C up to +80° C	-40°C bis +90° C -40°C up to +90° C	-30°C bis +90° C -30°C up to +90° C	-50°C bis +110° C -50°C up to +110° C
ZUL. KURZFRISTIGE TEMPERATURSPITZEN PERMISSIBLE SHORT TERM TEMPERATURE PEAKS	-60°C bis +80° C -60°C up to +80° C	-50°C bis +120° C -50°C up to +120° C	-40°C bis +120° C -40°C up to +120° C	-60°C bis +150° C -60°C up to +150° C
DÄMPFUNG DAMPING	Sehr gut Very good	Gut Good	Mittel Medium	Gering Low
ELASTIZITÄT ELASTICITY	Weich Soft	Mittel Medium	Hart Hard	Sehr hart Very hard
ABRIEBSFESTIGKEIT ABRASION RESISTANCE	Sehr gut Very good	Sehr gut Very good	Gut Good	Gut Good
DAUERFESTIGKEIT DURABILITY	Ausgezeichnet excellent	Sehr gut Very good	Sehr gut Very good	Sehr gut Very good
EINSATZBEREICHE TYPICAL APPLICATIONS	Allgemeine Antriebe, auch mit Drehschwingungsgefährdung Normal drives also resonance speed possibility	Allgemeine Antriebe Normal drives	Allgemeine Antriebe mit erhöhten Belastungen Normal drives with high performance	Hohe Belastbarkeit mit geringem Verdrehwinkel High performance with small torsional angle

## KUPPLUNGS-AUSWAHL

Es ist das größtmögliche Drehmoment  $T_N$  zugrunde zu legen.  
Katalogdrehmoment  $T_{KN}$  multipliziert mit allen Betriebsfaktoren.

$$T_N = T_{KN} \times K1 \times K2 \times K3$$

Für drehschwingungsgefährdete Anlagen ist bei der Kupplungs-  
auswahl die kritische Drehzahl zu berücksichtigen.

## BOHRUNGS-AUSFÜHRUNGEN

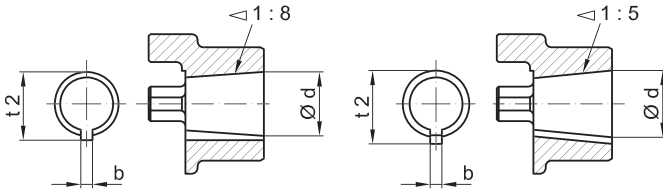

### KEGEL/TAPER 1:8

CODE	BOHRUNGSANGABEN BORE DETAILS			
	$d_s + 0,05$	$b + 0,05$	$t_2 + 0,1$	L
... N/1	9,7	2,4	10,7	17
... N/1c	11,6	3	12,9	16,5
... N/1e	13	2,4	13,8	21
... N/1d	14	3	15,5	17,5
... N/1b	14,3	3,2	15,7	19,5
... N/2	17,2	3,2	18,3	24
... N/2a	17,2	4	19,0	24
... N/2b	17,2	3	18,4	24
... N/3	22	4	23,5	28
... N/4	25,4	4,78	27,8	36
... N/4b	25,4	5	28,2	36
... N/4a	27	4,78	28,8	32,5
... N/4g	28,45	6	29,3	38,5
... N/5	33	6,35	35,5	44
... N/5a	33	7	35,5	44
... N/6	43,05	7,95	46,5	51
... N/6a	41,15	8	44,2	42,5

### KEGEL/TAPER 1:5

CODE	BOHRUNGSANGABEN BORE DETAILS			
	$d_s + 0,05$	$b$ js 9	$t_2 + 0,1$	L
... A 10	9,85	2	10,85	11,5
... B 17	16,85	3	18,65	18,5
... C 20	19,85	4	22,05	21,5
... Cs 22	21,95	3	23,75	21,5
... D 25	24,85	5	27,75	26,5
... E 30	29,85	6	32,45	31,5
... F 35	34,85	6	37,45	36,5
... G 40	39,85	6	42,45	41,5

Vor den Code ist die jeweilige Kupplungsgröße zu setzen: z. B.  
24/30 N/2a

Für Profile nach DIN und SAE sowie Zollbohrungen bitte separa-  
rate Liste anfordern.

This size of coupling should be inserted before the code: e.g.  
24/30 N/2a

For splines acc. to DIN and SAE as well as for inch bores please  
ask for separate list.

## COUPLING SELECTION

The largest possible torque  $T_N$  should be used as a basis.  
The catalogue torque has to be multiplied with all safety factors.

$$T_N = T_{KN} \times K1 \times K2 \times K3$$

## BORE CODES

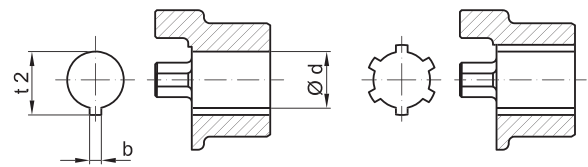

### ZOLLBOHRUNGEN / INCH BORES

CODE	METRISCH METRIC mm			ZOLL INCH	
	$d_s$	$b + 0,05$	$t_2 + 0,1$	$d_s$	b
DNB	11,11 M7	2,4	12,5	$7/16$	$3/32$
V	11,11 + 0,03	3,2	12,6	$7/16$	$1/8$
Ta	12,7 + 0,03	3,2	14,3	$1/2$	$1/8$
E	15,87 + 0,03	3,2	17,5	$5/8$	$1/8$
Ed	15,87 + 0,03	4,75	18,1	$5/8$	$3/16$
ES	15,88 + 0,03	4,0	17,7	$5/8$	$5/32$
Ad	19,02 + 0,03	3,2	20,7	$3/4$	$1/8$
A	19,05 + 0,03	4,78	21,3	$3/4$	$3/16$
Gs	22,22 + 0,03	4,78	24,4	$7/8$	$3/16$
G	22,22 + 0,03	4,75	24,7	$7/8$	$3/16$
F	22,22 + 0,03	6,35	25,2	$7/8$	$1/4$
B	25,37 + 0,03	4,78	27,8	1	$3/16$
Bs	25,38 + 0,03	6,37	28,3	1	$1/4$
HS	25,4 + 0,03	6,35	28,7	1	$1/4$
SB	28,58 + 0,03	6,35	31,5	$1 1/8$	$1/4$
Sd	28,58 + 0,03	7,93	32,1	$1 1/8$	$5/16$
Js	31,75 + 0,03	6,35	34,6	$1 1/4$	$1/4$
J	31,75 + 0,03	7,93	34,4	$1 1/4$	$5/16$
K	31,75 M7	7,93	35,5	$1 1/4$	$5/16$
KS	31,75 + 0,03	7,93	36,6	$1 1/4$	$3/16$
M	34,92 + 0,03	7,93	38,6	$1 3/8$	$5/16$
CB	36,5 + 0,03	9,55	38,6	$1 7/16$	$3/8$
C	38,07 + 0,03	9,55	42,5	$1 1/2$	$3/8$
N	41,25 + 0,03	9,55	45,6	$1 5/8$	$3/8$
L	44,45 K7	11,11	49,4	$1 3/4$	$7/16$
NM	47,625 + 0,03	12,73	53,5	$1 7/8$	$1/2$
DS	50,77 + 0,03	12,73	56,4	2	$1/2$
P	53,95 + 0,03	12,73	59,6	$2 1/8$	$1/2$
U	57,1 + 0,03	12,73	62,9	$2 1/4$	$1/2$
UB	60,3 + 0,03	15,87	67,6	$2 3/8$	$5/8$
W	69,85 M7	15,875	77,3	$2 3/4$	$5/8$
WA	73,0 + 0,03	19,05	81,7	$2 7/8$	$3/4$
WD	85,725 M7	22,225	95,8	$3 3/8$	$7/8$
WE	88,9 + 0,03	22,225	98,6	$3 5/8$	$7/8$
WF	92,075 M7	22,225	101,9	$3 5/8$	$7/8$



**BASISSORTIMENT ZYLINDRISCHE UND KONISCHE BOHRUNGEN**

**BASIC PROGRAMME METRIC AND CONICAL (TAPER) BORES**

SOFTEX® TYP / SIZE MATERIAL		KEGEL/TAPER 1:5				KEGEL/TAPER 1:8					ZOLLBOHRUNGEN / INCH BORES																		
		A 10	B17	C20	D25	N/1	N1d	N/2	N/2a	N/3	A	Bs	C	Ed	Es	F	G	K	L	M	N	NM	P	Sb	Sd	Ta	WA	WD	
19/24	Alu-D	•				•	•				•					•											•		
	S	•				•	•				•					•													
24/30	Alu-D	•	•	•	•	•	•	•	•	•	•	•		•	•	•	•							•					
	S	•	•	•	•						•					•													
28/38	Alu-D		•	•	•					•	•	•	•	•	•	•	•	•						•		•			
	S		•	•	•					•	•	•	•	•	•	•	•	•		•									
38/45	Alu-D		•		•					•	•	•	•	•	•	•	•	•											
	GG		•		•					•	•	•	•	•	•	•	•	•		•	•								
42/55	GG		•		•					•	•	•	•	•	•	•	•	•			•	•							
48/60	GG										•	•	•	•	•	•	•	•	•	•	•	•	•						
55/70	GG										•	•	•	•	•	•	•	•	•	•	•	•	•						
65/75	GG										•	•	•	•	•	•	•	•	•	•	•	•	•				•		
75/90	GG																									•	•	•	

SOFTEX® TYP / SIZE MATERIAL		NABE/HUB	FERTIGBOHRUNGEN ISO-PASSUNG H7, NUT NACH DIN 6885, BLATT 1 FINISH BORES ACC. ISO-STANDARD H7, KEYWAY ACC. DIN 6885, SHEET 1																																						
			6	8	9	10	11	12	14	15	16	18	19	20	22	24	25	28	30	32	35	38	40	42	45	48	50	55	60	65	70	75	80	85	90	95	100				
19/24	AWD	A	•	•	•	•	•	•	•	•	•	•	•	•	•	•																									
		B														•	•	•																							
	S	B				•	•	•	•	•	•	•	•	•	•	•	•	•	•	•	•	•	•	•	•	•	•	•	•	•	•	•	•	•	•	•	•	•	•		
24/30	AWD	A				•	•	•	•	•	•	•	•	•	•	•	•	•	•	•	•	•	•	•	•	•	•	•	•	•	•	•	•	•	•	•	•	•	•		
		B														•	•	•	•	•	•	•	•	•	•	•	•	•	•	•	•	•	•	•	•	•	•	•	•		
	S	B				•	•	•	•	•	•	•	•	•	•	•	•	•	•	•	•	•	•	•	•	•	•	•	•	•	•	•	•	•	•	•	•	•	•		
28/38	AWD	A																																							
		B																																							
	S	B																																							
38/45	AWD	A																																							
		B																																							
	GG	A																																							
42/55	GG	A																																							
		B																																							
	GG	A																																							
48/60	GG	A																																							
		B																																							
	GG	A																																							
55/70	GG	A																																							
		B																																							
	GG	A																																							
65/75	GG	A																																							
		B																																							
	GG	A																																							
75/90	GG	A																																							
		B																																							
	GG	A																																							

• Standard-Länge / Standard length      ■ B-Nabe verlängert / B-hub extended

**SOFTEX®-ES SPIELFREIE KUPPLUNGEN**

**SOFTEX®-ES ZERO BACKLASH COUPLINGS**

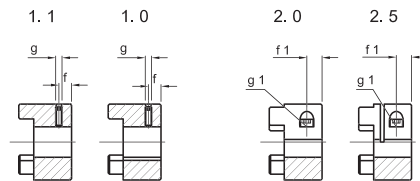
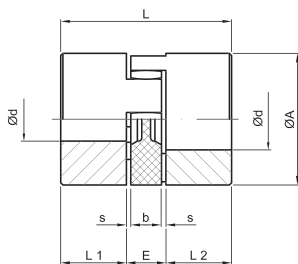

**PRODUKTBESCHREIBUNG**

- Unter Vorspannung spielfreie Wellenverbindung
- Werkstoff: Naben Aluminium
- 3-teilige einfachkardanische Kupplung
- Axial steckbar – einfache Blindmontage, keine zeitaufwändigen Verschraubungen
- Kleine Baumaße – geringe Schwungmomente
- Wartungsfrei
- Einfache optische Prüfung
- Verschiedene Elastomerhärten der Zahnkränze
- Lieferbar für alle üblichen Wellenabmessungen
- Fertigbohrungen nach ISO-Passung H7, (Klemmnabe F7), Passfedernute ab  $\varnothing 6$  nach DIN 6885 Bl. 1-JS9

**PRODUCT DESCRIPTION**

- Under initial tension no backlash shaft connection
- Material: Hubs made of aluminium
- Triple simple cardanic coupling
- Axially pluggable – simple blind mounting, no time-consuming screwings
- Small structural dimensions – low flyweehl effects
- Torsionally flexible, maintenance-free
- Simple optical test
- Different elastomer hardness of the gear rings
- Available for all usual shaft dimensions
- Finish bores acc. to ISO limit and fit H7 (clamp hub F7) keyway from  $\varnothing 6$  acc. to DIN 6885 P.1-JS9

SOFTEX® ES TYP SIZE	UNGEBOHRT UNBORED	FERTIGBOHRUNGEN* FINISH BORES*				ABMESSUNGEN DIMENSIONS mm							KLEMMSCHRAUBE CLAMPING SCREW			
		NABENAUSFÜHRUNG HUB TYPE				A	L	L <sub>1</sub> L <sub>2</sub>	E	b	s	(1,0) (1,1) g	f	(2,0) (2,5) g <sub>1</sub>	f <sub>1</sub>	T <sub>A</sub> [Nm]
		d <sub>min</sub>	1,0 d <sub>max</sub>	1,1 d <sub>max</sub>	2,0/2,5 d <sub>max</sub>											
<b>MAT. - ALUMINIUM</b>																
9	x	4	9	11	11	20	30	10	10	8	1,0	M4	5	M2,5	5,0	0,76
14	x	4	15	16	16	30	35	11	13	10	1,5	M4	5	M3	5,0	1,34
19/24	x	6	24	24	20	40	66	25	16	12	2,0	M5	10	M6	12,0	10,5
24/30	x	10	30	30	28	55	78	30	18	14	2,0	M5	10	M6	10,5	10,5
28/38	x	10	38	38	38	65	90	35	20	15	2,5	M8	15	M8	11,5	25,0
38/45	x	15	45	45	45	80	114	45	24	18	3,0	M8	15	M8	15,5	49,0

\* Sonderbohrungen auf Anfrage

\* Special bores on request

**BOHRUNGSBEREICH Ød UND ZUGEHÖRIGE ÜBERTRAGBARE DREHMOMENTE (NM) DER KLEMMNABE (2.0/2.5)**

**BORE RANGE Ød CORRESPONDING TRANSFERABLE TORQUES (NM) OF THE CLAMPING HUB (2.0/2.5)**

SOFTEX® ES	8	9	10	11	14	15	16	19	20	24	25	28	30	32	35	38	40	42	45
9	2,5	2,6	2,7	2,8															
14	5,1	5,3	5,5	5,6	8,1	6,3	6,5												
19/24	25	26	27	27	29	30	31	32	34										
24/30			34	35	36	38	39	19	41	43	45	46							
28/38					80	81	81	85	87	91	92	97	99	102	105	109			

Fertigbohrungen Nabenausführung 1.0 und 1.1 Passung H7, Ausführung 2.0 und 2.5 Passung F7 Nut nach DIN 6885. Blatt 1 Tol. JS 9

Finish bores hub types 1.0 and 1.1 limit and fit H7, types 2.0 and 2.5 limit and fit F7 Keyway acc. to DIN 6885, Page 1, Tol. JS 9

SOFTEX® ES TYP SIZE	ZAHNKRANZ SPIDER SHORE®	DREHMOMENT/TORQUE Nm			MAX. 1) DREHZAHL MAX. SPEED 1/MIN V=30 m/s	STATISCHE DREHFEDER- STEIFE STATIC E LONGATION PER UNIT FORCE Nm/rad	ZUL. VERLAGERUNG BEI ADMISSIBLE MISALIGNMENT n=1500 1/min			RADIALFEDERSTEIFE RADIAL ELONGATION PER UNIT FORCE Cr, N/mm	GEWICHT WEIGHT kg	MASSENTRÄGHEITS- MOMENT J ANGULAR MOMENTUM kg/cm²
		TK <sub>SP</sub>	TK <sub>N</sub>	TK <sub>MAX</sub>			axial Δka mm	radial Δkr mm	winkelig angular Δkw, Grad			
9	64D	0,45	6	12	28000	74	0,8	0,05	0,9	739	0,015	0,01
	92A		3	6		32		0,15	1,0	260	0,015	0,01
	98A (Standard)		5	10		51		0,09	0,9	520	0,015	0,01
14	64D	1	16	32	13000	234	1,0	0,06	0,8	856	0,06	0,06
	92A		7,5	15		114		0,15	1,0	335	0,06	0,06
	98A (Standard)		12,5	25		172		0,09	0,9	605	0,06	0,06
19/24	64D	2,5	21	42	10000	1240	1,2	0,04	0,8	2830	0,13	0,37
	92A		10	20		570		0,10	1,0	1120	0,13	0,37
	98A (Standard)		17	34		855		0,07	0,9	2010	0,13	0,37
24/30	64D	-	75	150	7000	2980	1,4	0,07	0,8	3696	0,28	1,35
	92A		35	70		1430		0,14	1,0	1780	0,28	1,35
	98A (Standard)		60	120		2060		0,10	0,9	2565	0,28	1,35
28/38	64D	-	200	400	6000	4350	1,5	0,09	0,8	4348	0,46	3,10
	92A		95	190		2292		0,15	1,0	1785	0,46	3,10
	98A (Standard)		160	320		3440		0,11	0,9	3200	0,46	3,10
38/45	64D	-	405	810	5000	10540	1,8	0,09	0,8	6474	0,90	9,62
	92A		190	650		4584		0,17	1,0	2350	0,90	9,62
	98A (Standard)		325	380		7160		0,12	0,9	4400	0,90	9,62







- Bei höheren Drehzahlen ist dynamisches Auswuchten der Naben erforderlich.
- Das Längenmaß L vergrößert sich um die angegebene Δka-Werte.
- Die aufgeführten Verlagerungswerte sind allgemeine Richtwerte.
- Bei gleichzeitigem Winkel- und Radialversatz können die angegebenen Werte nur anteilmäßig ausgenutzt werden.
- Die Tabellenwerte sind gültig für eine Betriebstemperatur T=+30°C. Bei einer Temperaturerhöhung müssen die zulässigen Drehmomente und die max. zulässigen Radial- und Winkelverlagerungswerte mit dem Temperaturfaktor St multipliziert werden.

- In case of higher speeds a dynamic balancing of the hubs is required.
- The length dimension L is increased by the indicated Δka values.
- The specified misalignment values are general approximate values.
- In case of current angular and radial misalignment the indicated values can only be utilized proportionately.
- The table values are valid for an operating temperature T=+30°C. In case of a temperature increase the admissible torques and the max. admissible radial and angular misalignment values must be multiplied by the temperature factor St.

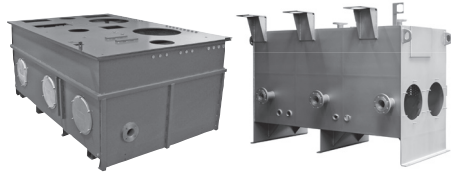
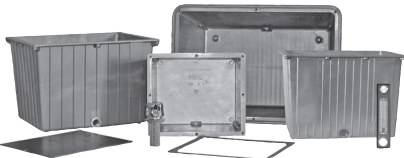
TEMPERATUR TEMPERATURE	- 25 <+ 30°C	+ 30 <+ 40°C	+ 40 <+ 60°C	+ 60 <+ 80°C
FAKTOR ST FACTOR ST	1,0	0,8	0,7	0,6

## GESAMTLIEFERPROGRAMM

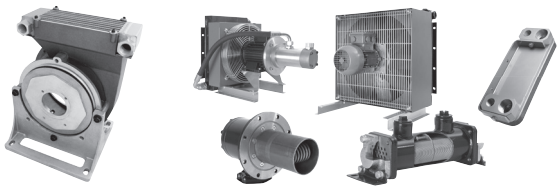
## DELIVERY PROGRAMME

<p><b>Ölbehälter aus Stahl / Edelstahl</b> Oil tanks made of steel / stainless steel</p>	
<p><b>Ölbehälter aus Aluminium</b> Oil tanks made of aluminium</p>	
<p><b>Reinigungsdeckel und sonstiges Behälterzubehör</b> <b>Niveau- und Temperaturüberwachung</b> Cleaning covers and further accessories Level- and temperature indicators</p>	
<p><b>Tankheizungen</b> Tank heaters</p>	
<p><b>Pumpenträger und Zubehör</b> Bellhousings and accessories</p>	
<p><b>Pumpenträger mit Öl-Kühler</b> <b>Wärmetauscher</b> <b>Gelötete Platten-Wärmetauscher</b> Bellhousing with oil-cooler Heat exchangers Brazed plate heat exchanger</p>	
<p><b>SOFTEX® elastische und drehspielfreie Wellenkupplungen</b> SOFTEX® elastic and no backlash shaft couplings</p>	
<p><b>STAREX® flexible Kupplungen</b> STAREX® flexible couplings</p>	
<p><b>Kupplungen für Verbrennungsmotoren</b> Diesel engine couplings</p>	