

Gas spring G04-12

Extension force F1	10 - 180 Newton
Progression	25 %
Piston rod	Ø 4 mm, 8mm, steel, hard chrome plated
Cylinder	Ø 12 mm, steel, black spray coated
Threads	Steel zinc plated

GZ 05

GZ 05

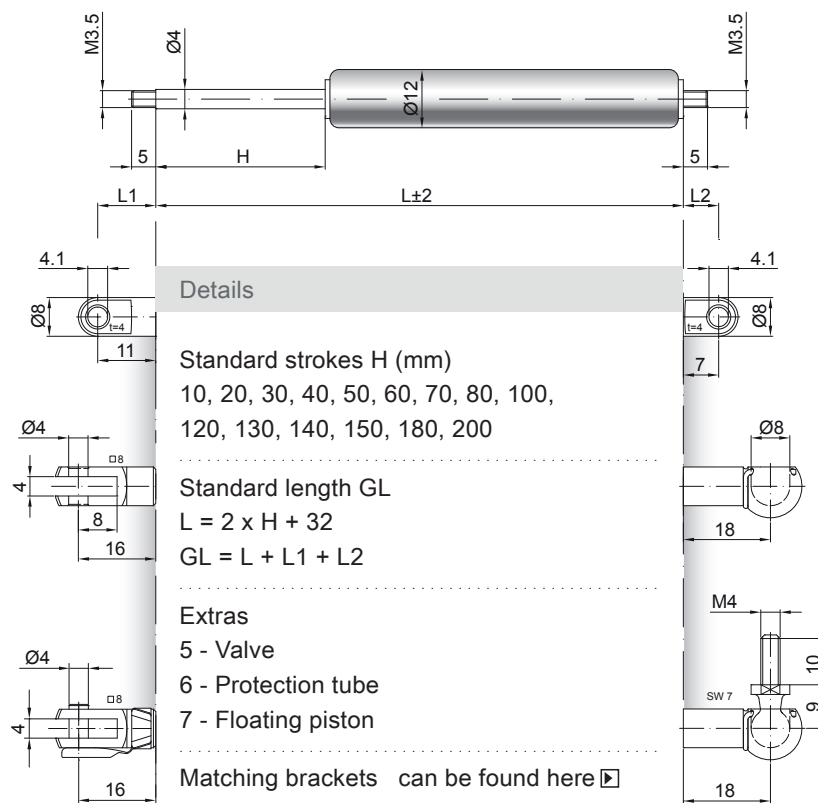

AU 11

AB 07

only possible on cylinder end

GA 16

PX 18

GG 16

WX 18