

- 1** Proportional valve
- 2** Outlet flange with thread connection
- 3** Inlet flange with thread connection
- 4** M8 Power supply
- 5** M12 Connector signal interface
- 6** Micro USB port
- 7** 3 LEDs operating mode

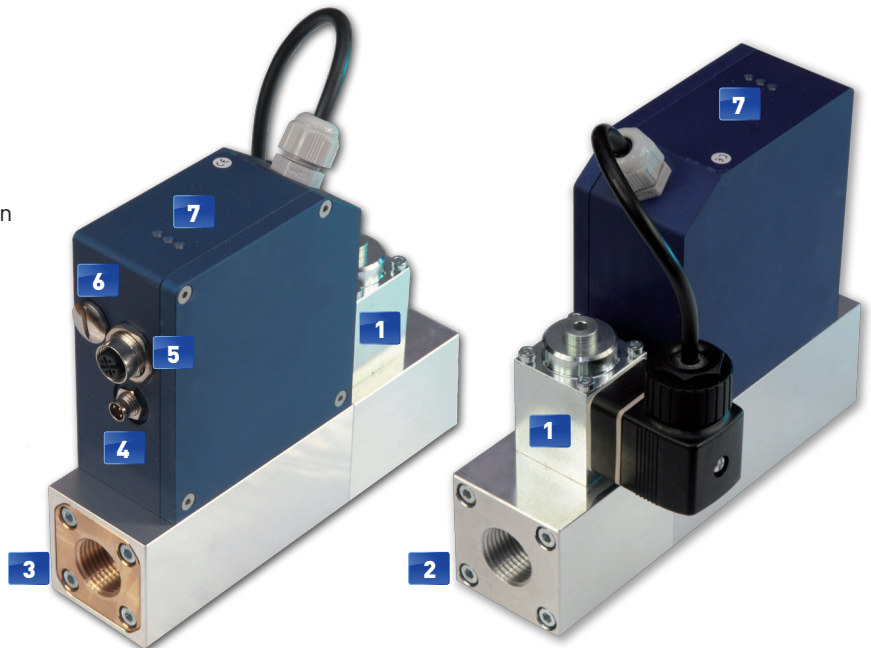

backsight of flox[on] B economy and extended

frontsight of flox[on] B stainless steel

### DIMENSIONS

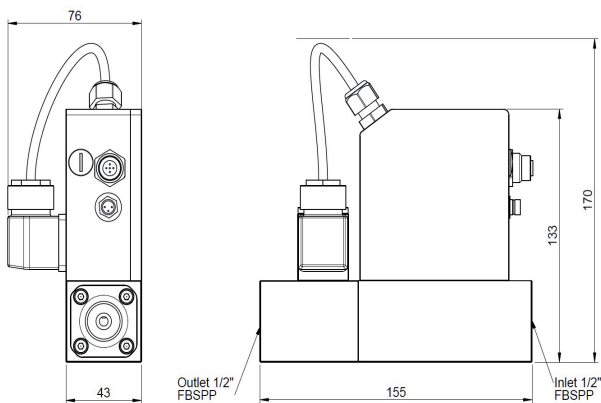

### LED AND OPERATING MODUS

	Power
LED 2	In operation/run
LED 3	Error

### CONNECTION ASSIGNMENT



#### M8 POWER SUPPLY

Pin 1	24 VDC
Pin 3	0 V
Pin 4	PE, Ground
20 to 28 VDC at max. 300 mA	

#### USB PORT

The USB Port connects the flox[on] B with a PC.

### M12 ANALOG CONNECTOR

Pin 1	Set Value	4-20 mA → AOP
Pin 2	Set Value	0 V
Pin 3	Real value	4-20 mA → AIP
Pin 4	Real value	0 V
Pin 5	Dig. Input	24 VDC, Bypass Function

## AVAILABLE MODIFICATIONS OF FLOX[ON] B

The measurement of all flox[on] B mass flow controller is based on the principle of thermal anemometry. The measuring cell is located in a bypass.  
The measurement of the gas flow is temperature and pressure compensated. The regulation of the flow will be made by a pressure compensated proportional valve which is insensitive to incoming pressure (0-16 bar) as well as outflow pressure. The valve is controlled by a solenoid and can be opened fully under any pressure conditions.  
All flox[on] B mass flow controller are equipped with a high performance micro controller.

Three standard modifications of the flox[on] B are available:

The **economy version** is useful for standard applications with gases like compressed air, nitrogen or argon.

The **extended version** is ready to handle gases like hydrogen, methane and oxygen.

The **stainless steel version**, free of brass components, can be used in applications like food industry.

PRODUCT FEATURES		ECONOMY	EXTENDED	STAINLESS STEEL
Maximum flow	Nlmin <sup>-1</sup>	200	250	250
Minimum flow	Nlmin <sup>-1</sup>	0.5	0.5	0.5
Maximum operating pressure	bar	16	16	16
Regulation ratio		1 : 30	1 : 50	1 : 50
Device Accuracy		1% Full Scale	1% Full Scale	1% Full Scale
Step response time (10% - 90%)	s	1.5 or less	1.5 or less	1.5 or less
Operating temperature	°C	from -10 to +60	from -10 to +60	from -10 to +60

GASES	ECONOMY	EXTENDED	STAINLESS STEEL
Calibration media (see also chapter calibration)	standard: comp. air, *	standard: comp. air, *	standard: comp. air, *
Process media (gas)	comp. air, N <sub>2</sub> , Ar, CO <sub>2</sub>	comp. air, N <sub>2</sub> , Ar, CO <sub>2</sub> , H <sub>2</sub> , CH <sub>4</sub> , O <sub>2</sub> , **	comp. air, N <sub>2</sub> , Ar, CO <sub>2</sub> , H <sub>2</sub> , CH <sub>4</sub> , O <sub>2</sub> , **

\* In individual cases, if desired by the customer, the calibration can be made directly with the specific gas intended for use.

\*\* In other cases a compatibility check is required.

MATERIALS	ECONOMY	EXTENDED	STAINLESS STEEL
Housing	Aluminium and Brass	Aluminium and Brass	steel X2CrNi18-9, 1.4307 and steel X2CrNiMo17-12-2, 1.4404
Valveparts	Brass	Brass	steel X2CrNi18-9, 14307
Inlet / Outlet Port	FBSPP 1/2"	FBSPP 1/2"	FBSPP 1/2", 3/8", 1/4"
Sealing	NBR, FPM	NBR, FPM	NBR, FPM, other
Protection	IP54	IP65	IP65

## USP PORT AND DATA EXCHANGE

You can get the software by asking for it (info@fc-technik.ch). It requires Windows. The software enables to operate the flox[on] B without any other process control.

The software allows to:

- to get all information about the device,
- to see and to manipulate the calibration data,
- to have a look at the actual operation and to overwrite the set point.

Though the measuring cell does not require a recalibration for the rest of its lifetime it might be possible in very special processes to manipulate the calibration (here done in changing three calibration points, that are green marked).

Before using this menu, it is recommended to discuss it with FC Technik.

## DEVICE

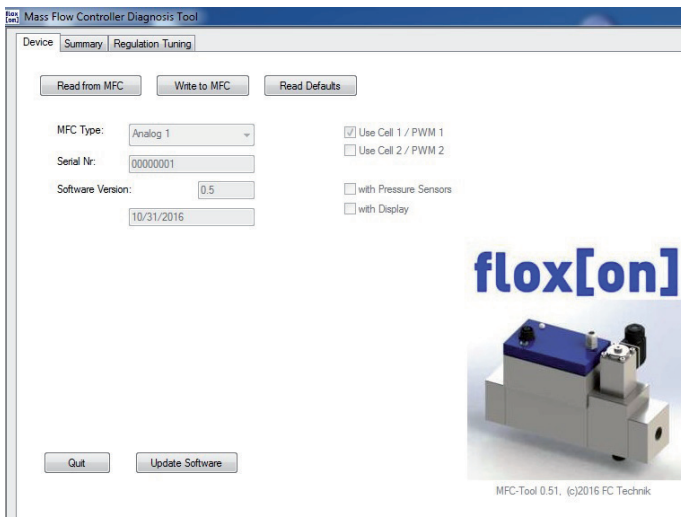

The menu device shows all relevant information about the flox[on] that is in use.

## REGULATION TUNING

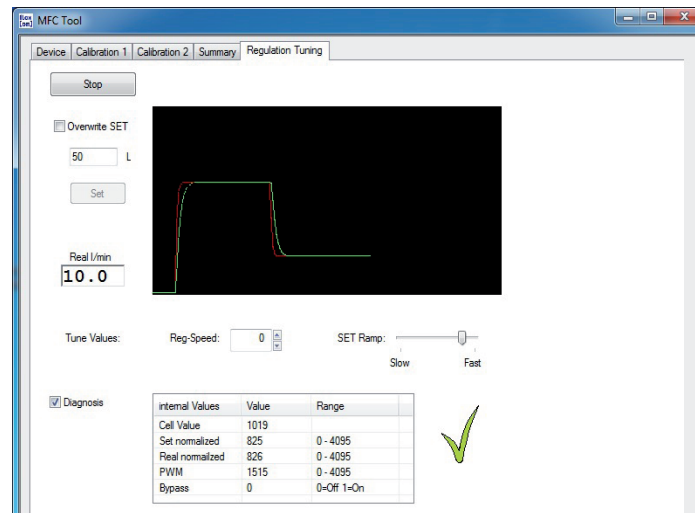

The green line shows the set point, the red line the running point in real time. It is possible to overwrite the set point at every time. In this case it had been done, changing from 50 to 10 lmin<sup>-1</sup> (e.g.). SET Ramp. can be positioned to fast. or slow.

## CALIBRATION

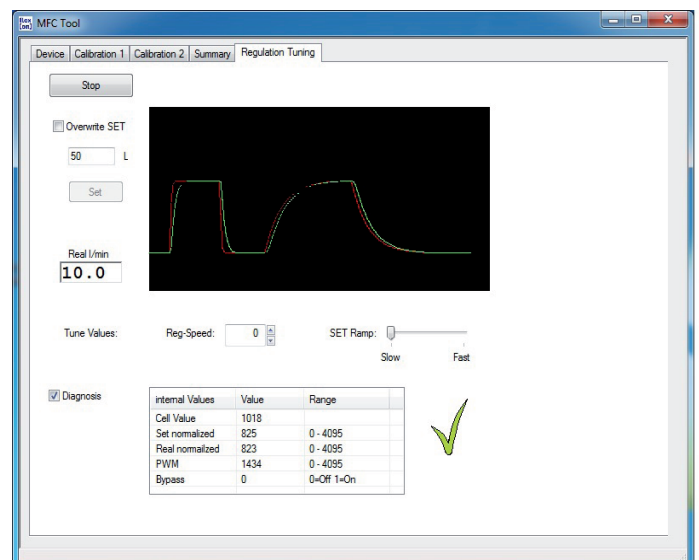
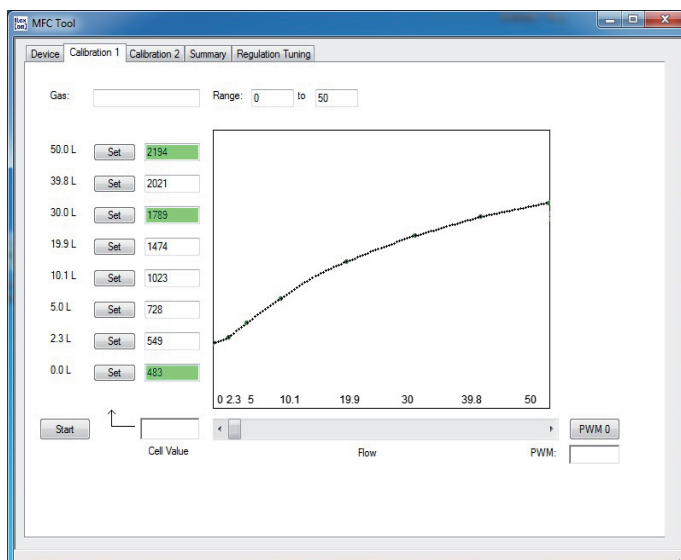

### IMPORTANT NOTICES

To ensure trouble-free operation, the **flox[on] B** should be installed in a horizontal position. If installed vertically, the device could produce faulty measurements under certain conditions.

The **flox[on] B** is maintenance-free even under harsh conditions. In case of a fault or failure of the measuring cell, please contact the service center.

When delivered, the **flox[on] B** comes in secure transport packaging. It can be stored under dry conditions for up to two years before installation.

The **flox[on] B** is intended solely for use with gases.

Liquids will ruin the measuring cell. This includes gas condensation, for example, if temperatures during operation drop below the condensation point.

Particulate matter in the form of gas impurities may clog the filter discs and decrease the performance of the **flox[on] B**.

Incorrect wiring can destroy the electronics.

### CALIBRATION

Before delivery, the measuring cell in every **flox[on] B** is calibrated with atmospheric air. There are correction factors for applications using other gases.

In individual cases, if desired by the client, the calibration can be made directly with the specific gas intended for use.

The measuring cell does not require a recalibration for the rest of its operating life.

If a mixed gas such as air or natural gas is used, it should be noted that a change in the composition of the gas can occur during operation.

In such cases, and for all other questions about calibration, please contact our service center (see back page of this manual).

### CORRECTION FACTORS

GAS		CORRECTION FACTOR
Hydrogen*	H <sub>2</sub>	0,7
Argon	Ar	0,95
Nitrogen	N <sub>2</sub>	1,0
Oxygen	O <sub>2</sub>	1,0
Methane	CH <sub>4</sub>	1,1
Carbon dioxide	CO <sub>2</sub>	1,35

\* For applications using hydrogen gas, we recommend that the **flox[on] B** be calibrated directly with hydrogen by FC Technik

### CONTACT

#### FC Technik AG

St. Gallerstrasse 340  
CH-8409 Winterthur

Tel. +41 (0) 52 238 01 75  
Fax +41 (0) 52 238 01 77

www.fc-technik.com  
info@fc-technik.ch

### GUARANTEE

The **flox[on] B** is guaranteed for 2 years.