

Rotac® Hyd-ro-ac® Products – Rotary Actuator: LP-11 THRU LP-24

(Dimensional Data) (Performance Data) (Test Parameters) (Product Catalog) (LP Order Form)

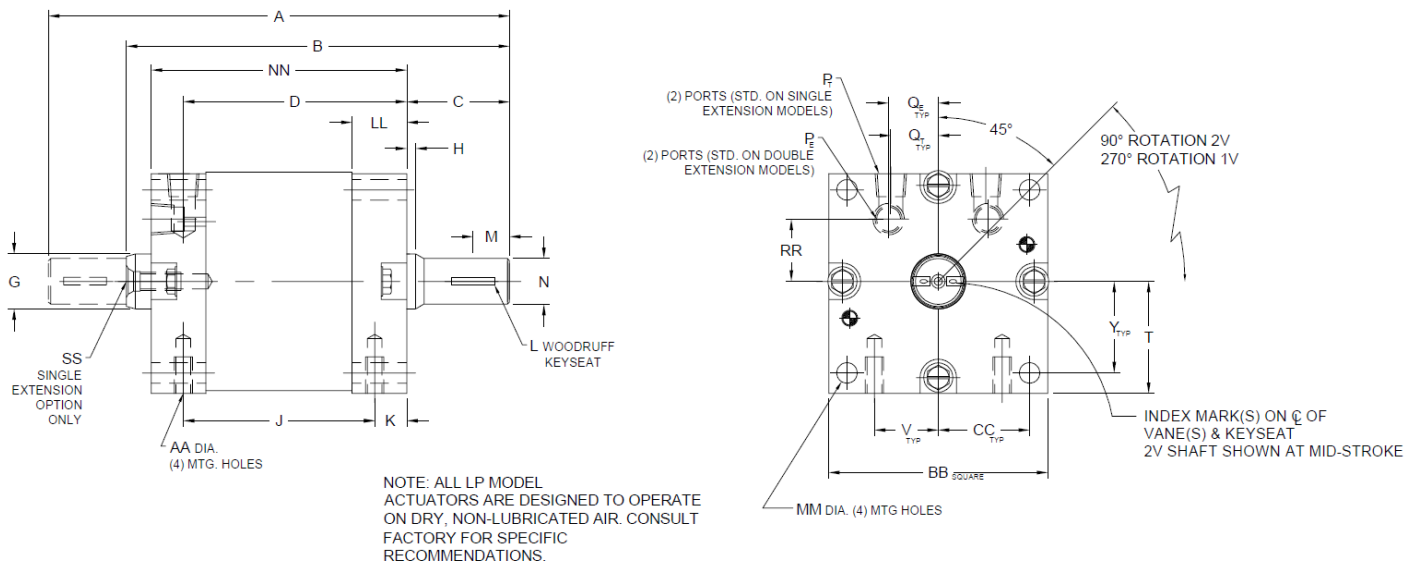

IMPORTANT NOTES TO AVOID ACTUATOR DAMAGE AND VOIDED WARRANTY:

1. Design considerations should be made to limit the axial and radial loading applied to the actuator. Contact factory if axial and/or radial loading must be applied to the actuator. Unapproved axial and/or radial loading will void the actuator's warranty.
2. External stops must be used to limit shaft rotation for most applications. Using the actuators internal components as rotational stops will cause damage and void the actuators warranty.
3. All LP models are designed to operate on dry, non-lubricated air. Consult factory for specific recommendations.

DIMENSION IN INCHES (MILLIMETERS)				
	LP-11	LP-12	LP-22	LP-24
A	4.00 (101.60)	5.00 (127.00)	6.32 (160.53)	8.32 (211.33)
B	3.18 (80.77)	4.18 (106.17)	5.25 (133.35)	7.25 (184.15)
C	1.00 (25.40)	1.00 (25.40)	1.41 (35.81)	1.41 (35.81)
D	1.75 (44.45)	2.75 (69.85)	3.06 (77.72)	5.06 (128.52)
G	Ø0.44 (Ø11.18)	Ø0.44 (Ø11.18)	Ø0.75 (Ø19.05)	Ø0.75 (Ø19.05)
H	0.09 (2.29)	0.09 (2.29)	0.12 (3.05)	0.12 (3.05)
J	1.63 (41.10)	2.63 (66.80)	2.63 (66.80)	4.63 (117.60)
K	0.19 (4.80)	0.19 (4.80)	0.44 (11.18)	0.44 (11.18)
L	1/16 X 1/2 #204 (1.59 X 12.70)	1/16 X 1/2 #204 (1.59 X 12.70)	1/8 X 5/8 #405 (3.18 X 15.88)	1/8 X 5/8 #405 (3.18 X 15.88)
M	0.38 (9.65)	0.38 (9.65)	0.50 (12.70)	0.50 (12.70)

N₄	Ø0.3735 (Ø9.487)	Ø0.3735 (Ø9.487)	Ø0.6235 (Ø15.837)	Ø0.6235 (Ø15.837)
P_E	1/8-27 NPTF	1/8-27 NPTF	1/8-27 NPTF	1/8-27 NPTF
P_T	#10-32	#10-32	1/8-27 NPTF	1/8-27 NPTF
Q_E	0.48 (12.19)	0.48 (12.19)	0.65 (16.51)	0.65 (16.51)
Q_T	0.44 (11.17)	0.44 (11.17)	0.65 (16.51)	0.65 (16.51)
T₃	1.030 (26.16)	1.030 (26.16)	1.530 (38.86)	1.530 (38.86)
V	0.60 (15.24)	0.60 (15.24)	0.88 (22.35)	0.88 (22.35)
Y	0.84 (21.34)	0.84 (21.34)	1.25 (31.75)	1.25 (31.75)
AA	#10-24 0.38 DP	#10-24 0.38 DP	1/4-20 0.50 DP	1/4-20 0.50 DP
BB	2.06 (52.32)	2.06 (52.32)	3.06 (77.72)	3.06 (77.72)
CC	0.84 (21.34)	0.84 (21.34)	1.25 (31.75)	1.25 (31.75)
LL	0.50 (12.70)	0.50 (12.70)	0.75 (19.05)	0.75 (19.05)
MM	0.21	0.21	0.27	0.27
NN	2.00 (50.80)	3.00 (76.20)	3.50 (88.90)	5.50 (139.70)
RR	0.60 (15.24)	0.60 (15.24)	0.85 (21.59)	0.85 (21.59)
SS	#10-24UNC-2B TAP 0.50 DEEP (12.70)	#10-24UNC-2B TAP 0.50 DEEP (12.70)	1/4-20UNC-2B TAP 0.62 DEEP (15.75)	1/4-20UNC-2B TAP 0.62 DEEP (15.75)

³ TOLERANCE ±0.005 (0.13)

⁴ TOLERANCE ±0.0005 (0.01)

SINGLE VANE 270° ROTATION (±1°)									
MODEL	TORQUE in-lbs (N-m)					VOLUMETRIC DISPLACEMENT in ³ (cm ³)		APPROX. WEIGHT lb (kg)	THRUST LOAD lb (kg)
	50 psi (3.4 bar)	75 psi (5.2 bar)	100 psi (6.9 bar)	125 psi (8.6 bar)	150 psi (10.3 bar)	PER 270°	PER Radian		
LP-11	4 (0.45)	7 (0.79)	11 (1.24)	14 (1.58)	17 (1.92)	0.839 (13.75)	0.178 (2.92)	0.58 (0.26)	8 (3.63)
LP-12	10 (1.13)	16 (1.81)	23 (2.60)	29 (3.28)	36 (4.07)	1.68 (27.54)	0.356 (5.83)	0.75 (0.34)	8 (3.63)
LP-22	25 (2.83)	41 (4.63)	57 (6.44)	73 (8.25)	89 (10.06)	3.86 (63.27)	0.819 (13.42)	2.1 (0.96)	12 (5.44)
LP-24	51 (5.76)	84 (9.49)	116 (13.11)	148 (16.72)	180 (20.34)	7.68 (125.9)	1.63 (26.72)	3.1 (1.41)	12 (5.44)

*NOTES: 1. External stops should be used to limit angular travel as the actuator shoes are not designed as mechanical stops.

2. Consult factory for applications requiring low breakaway and maximum torque output.

DOUBLE VANE 90° ROTATION (±1°)									
MODEL	TORQUE in-lbs (N-m)					VOLUMETRIC DISPLACEMENT IN ³ (cm ³)		APPROX. WEIGHT lb (kg)	THRUST LOAD lb (kg)
	50 psi (3.4 bar)	75 psi (5.2 bar)	100 psi (6.9 bar)	125 psi (8.6 bar)	150 psi (10.3 bar)	PER 270°	PER Radian		
LP-11	11 (1.24)	19 (2.15)	26 (2.94)	34 (3.84)	42 (4.75)	0.559 (9.16)	0.356 (5.83)	0.62 (0.28)	8 (3.63)
LP-12	26 (2.94)	43 (4.86)	59 (6.67)	75 (8.48)	92 (10.40)	1.12 (18.36)	0.713 (11.69)	0.81 (0.37)	8 (3.63)
LP-22	58 (6.55)	94 (10.62)	130 (14.69)	166 (18.76)	202 (22.83)	2.56 (41.96)	1.63 (26.72)	2.2 (1.00)	12 (5.44)
LP-24	129 (14.58)	209 (23.62)	289 (32.66)	370 (41.81)	450 (50.85)	5.14 (84.24)	3.27 (53.60)	3.3 (1.51)	12 (5.44)

*NOTES: 1. External stops should be used to limit angular travel as the actuator shoes are not designed as mechanical stops.

2. Consult factory for applications requiring low breakaway and maximum torque output.

TEST PARAMETERS - AIR			
MODEL	MAX BREAK IN psi (bar)	BY-PASS LEAKAGE-MAX ALLOWABLE	
		ft ³ /min AT 100 psi (6.9 bar)	cm ³ /min AT 100 psi (6.9 bar)
LP-11-1V	15 (1.03)	0.20	5665
LP-11-2V	12 (0.83)	0.25	7080
LP-12-1V	12 (0.83)	0.20	5665
LP-12-2V	10 (0.69)	0.25	7080
LP-22-1V	10 (0.69)	0.20	5665
LP-22-2V	10 (0.69)	0.25	7080
LP-24-1V	10 (0.69)	0.20	5665
LP-24-2V	10 (0.69)	0.25	7080

HOW TO ORDER LP-11 THRU LP-24

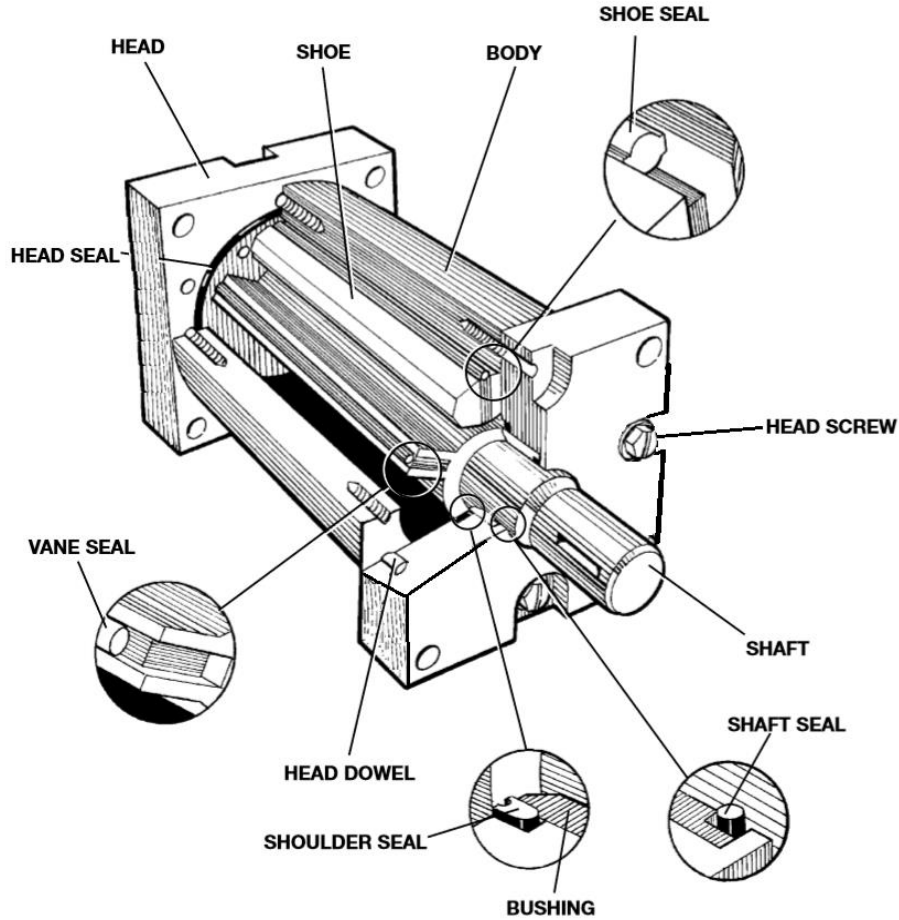

HOW TO ORDER

Please fill in ALL blocks in accordance with the KEY numbers and letters shown below.

EXAMPLE: LP - 22 - 1V - DE - WK - FLG - TP

- - - - - -

BLOCK # 1 2 3 4 6 7 8

Block 1 (MODEL)

LP

Block 2 (SIZE)

11

12

22

24

Block 3 (VANES)

1V Single Vane

2V Double Vane

Block 4 (SHAFT EXTENSION)

SE Single Extension

DE Double Extension

Block 6 (SHAFT TYPE)

K Keyed

WK Woodruff Key

Z Special

Block 7 (MOUNTING)

FLG Flange

Z Special

Block 8 (PORTING)

TP Top Ports

EP End Ports

Z Special

NOTES: 1. Blocks "5" is not used for LP models

2. All "Z" (non-standard feature request) requires a "Request a Quote" to be filled out for Micromatic to review requirements