

Integrated Measuring System IMS  
for Ball and Roller Rail Systems

**R320103262 (2020.07)**  
Replaces: 2017.06  
EN

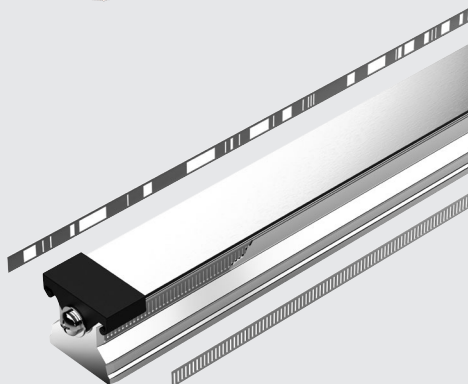

Instructions mechanic

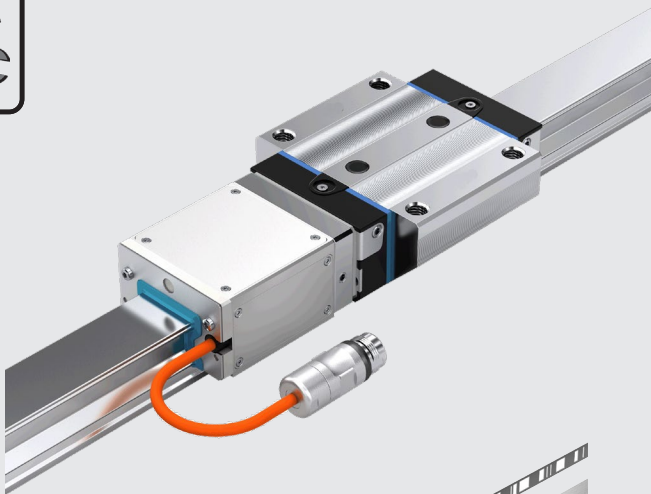

EN

The information in this document is for product description purposes only. No statement regarding any particular quality or suitability for any particular use can be derived from this information. The information given does not release the user from the obligation of own judgment and verification. It must be remembered that our products are subject to a natural process of wear and aging.

© Bosch Rexroth AG reserves all rights, including the right to apply for patent protection. It may not be reproduced or given to third parties without our consent. The title page contains an illustration of a sample configuration. The product as delivered can differ from the illustration. The original instructions are in the German language. Any dissemination of the product must include these instructions.

Die vorliegende Anleitung ist in folgenden Sprachen verfügbar.  
These instructions are available in the following languages.  
Les présentes instructions sont disponibles dans les langues suivantes.  
Le presenti istruzioni sono disponibili nelle lingue seguenti.  
Las presentes instrucciones están disponibles en los siguientes idiomas.  
As presentes instruções estão disponíveis nas seguintes línguas.  
本说明书有下列语言版本。

DE German (Original document)  
EN English  
FR Français  
IT Italiano  
ES Español  
PT Português  
ZH 德文

## Contents

1	About these instructions .....	4
2	Safety instructions .....	6
3	General notes on damage to product and property.....	11
4	Scope of supply.....	12
5	Product description .....	12
6	Transport and storage .....	16
7	Installation .....	16
8	Start-up .....	20
9	Operation .....	21
10	Maintenance and repair .....	22
11	Removal and replacement.....	24
12	Disposal.....	32
13	Technical data .....	32
14	Operating conditions .....	33
15	Ordering replacement parts.....	34
16	Troubleshooting and fault clearance.....	39
17	Service and support.....	41

# 1 About these instructions

## 1.1 Scope and purpose of the documentation

This documentation applies to the following products:

- Integrated Measuring System IMS according to the “Integrated Measuring System IMS” catalog.

This documentation is intended for assembly/installation personnel, line operators and machinery/plant users.







This documentation contains important information for proper and safe installation, operation, maintenance and disassembly of the product and for troubleshooting simple errors oneself.

► Before starting up the product into service read these instructions completely.

## 1.2 Required documentation

Documentation which is indicated by the book symbol  must be obtained before handling the product and must be adhered to:

**Table 1: Required documentation**

	<b>Title</b>	<b>Document number</b>	<b>Application</b>
	Integrated Measuring System IMS	R999000466	Catalog
	Integrated Measuring System IMS	R320103166	Instructions for electrical interfaces
	Ball Rail Systems	R999000464	Catalog
	Roller Rail Systems	R999000353	Catalog
	Instructions for Profiled Rail Systems	R320103885	Instructions
	Product data sheet for Dynalub 510	R310 2052	Catalog

The Rexroth documentation is available for download at [www.boschrexroth.com/mediadirectory](http://www.boschrexroth.com/mediadirectory).

## 1.3 Presentation of information

To enable users to work rapidly and safely with the product while following these instructions, this documentation uses standardized safety instructions, symbols, terms and definitions, and abbreviations. These are explained in the following sections.

### 1.3.1 Safety instructions in this manual

This manual contains safety instructions preceding any actions that involve a risk of personal injury or damage to property. The safety precautions described must be adhered to.

Safety instructions are structured as follows:



## SIGNAL WORD

### Type of hazard!

Consequences if ignored.

- ▶ Hazard avoidance precautions.

- Warning sign: draws attention to the hazard
- Signal word: indicates the severity of the hazard
- Type of hazard: indicates the type or source of the hazard
- Consequences: describes the consequences that may occur if the hazard avoidance precautions are ignored
- Hazard avoidance precautions: indicates how to avoid the hazard

The safety instructions cover the following hazard levels. The hazard level describes the risks involved if the safety instruction is not complied with.









Hazard levels as per ANSI Z535:

Warning sign, Signal word	Meaning
<b>DANGER</b>	Indicates an imminently hazardous situation which will result in death or serious injury if not avoided.
<b>WARNING</b>	Indicates a potentially hazardous situation which could result in death or serious injury if not avoided.
<b>CAUTION</b>	Indicates a potentially hazardous situation which may result in minor or moderate injury if not avoided.
<i>NOTE</i>	Damage to property: The product or surrounding environment could get damaged.

### 1.3.2 Symbols

The following symbols indicate notes that are not safety-critical but make the documentation easier to understand.

**Table 2: Meaning of the symbols**

Symbol	Meaning
	If this information is not observed, the product will not be optimally used or operated.
	Single, independent work step
1. 2. 3.	Numbered work steps The numbers indicate the sequence of the work steps.
	See section 7
	See Figure 7.1
	Screw with strength class...
	Tightening torque
	Clean
	Wear gloves

### 1.3.3 Abbreviations

The following abbreviations are used in this documentation:

**Table 3: Abbreviations and definitions**

Abbreviation	Meaning
IMS	Integrated Measuring System
IMS-I	Integrated Measuring System Incremental
IMS-A	Integrated Measuring System Absolute
BRS	Ball Rail System
RRS	Roller Rail System

## 2 Safety instructions

The product has been manufactured according to generally accepted standards of good engineering practice. Nevertheless, if these safety instructions and the

safety instructions given in the related documentation (instruction manuals, product catalogs) are not adhered to, there is a risk of personal injury and damage to property when using the product.

These safety instructions form part of the product instructions.

To avoid personal injury and damage to property:

- ▶ Before commencing any work with the product, be sure to read the product documentation carefully and completely.
- ▶ Make sure these safety instructions and the product documentation are always accessible to all users.
- ▶ When passing the product on to third parties, always include these safety instructions and all the required documentation.
- ▶ The product may only be mounted, started up and maintained in accordance with these safety instructions and the information given in the product documentation.

## 2.1 Intended use

The Integrated Measuring System (IMS for short) is an assembly. The IMS consists of components for precise linear movements and integrated position measuring. The product may be used in accordance with the technical documentation (➔ product catalog) for the following purposes:

- ▶ as a direct linear position sensing system in industrial environments (woodworking, laser welding, laser cutting, metal cutting and metal forming machine tools), automation technology.
- ▶ as linear encoder in applications with a linear motor.
- ▶ in interpolating axes in machine tools.
- ▶ in measuring machines within the scope of the achievable accuracy.
- ▶ for connection to display units, evaluation electronics for PCs and drive controllers.

The product is intended exclusively for professional use and not for private use.

Intended use also includes having read and understood the product documentation completely, in particular these “Safety instructions”.

The product is exclusively intended for incorporation into a final machine or a system or for assembly to other components for the purpose of building a final machine or a system.



The permitted operating conditions are determined by the individual components.

## 2.2 Misuse

Use of the product in any other way than as described under “Intended Use” is considered to be misuse and is therefore not permitted.

The product may only be used in applications or environments constituting a danger to the health and life of persons if this use – for example, in potentially explosive atmospheres covered by ATEX regulations – has been expressly specified and permitted in the product documentation.

Bosch Rexroth AG will not accept any liability for injury or damage caused by misuse of the product. The risks associated with any misuse of the product shall be borne by the user alone.

Misuse of the product includes:

- transporting people
- use in potentially explosive atmospheres
- use in direct contact with unpacked foodstuffs
- use in liquids
- use as a safety component, either mechanical or electrical
- use in environments with increased radioactivity
- use with clamping and braking units

## 2.3 Personnel training and qualifications

The activities described in these safety instructions and the product documentation require fundamental knowledge of mechanical and electrical engineering principles and familiarity with the associated technical terminology. For transporting and handling the product, additional skills are required in regard to the correct use of hoisting equipment and the associated fastening means.

In order to ensure safe use, these activities may therefore only be performed by appropriately trained specialists or instructed persons working under the supervision of a trained specialist.

A trained specialist is a person whose professional training, knowledge, experience and familiarity with the relevant regulations enable him/her to assess the tasks assigned to him/her, identify potential hazards and take appropriate safety precautions. A trained specialist must adhere to the relevant technical rules and standards and possess the necessary technical knowledge to do so.



Bosch Rexroth offers you support for training in specialist areas. You will find an overview of the training topics offered on the Internet at: <http://www.boschrexroth.com/didactic>



## 2.4 General safety instructions

The Integrated Measuring System uses state-of-the-art technology and complies with the relevant safety regulations. However, dangers can still arise.

Improper handling of these components, failure to comply with the safety instructions given here, and improper interventions can result in damage to property, injuries and, in extreme cases, death.

Persons who mount/install, operate, disassemble or maintain Rexroth products shall not be under the influence of alcohol, other drugs or medications which might affect their judgment or slow down their reactions.

- ▶ The safety rules and regulations of the country in which the product is used must be complied with.
- ▶ All current and applicable accident prevention and environmental regulations must be adhered to.
- ▶ The product may only be used when it is in technically perfect condition.
- ▶ Only manufacturer-approved accessories and replacement parts may be used in order to exclude danger to personnel caused by unsuitable replacement parts.
- ▶ The technical data and environmental conditions stated in the documentation for the product and accessories must be complied with.
- ▶ The product may only be used in safety-critical applications if this use has been expressly specified and permitted in the product documentation.
- ▶ The product must not be put into service until it has been verified that the final product (for example a machine or system) into which the product has been installed complies with the country-specific requirements, safety regulations and standards for the application.
- ▶ The product must never be altered or modified.
- ▶ The product must never be disassembled. The only exceptions are activities described in the section “Removal and replacement”.
- ▶ The components of the product have been designed to last for the product's service life. In exceptional cases, however, a defect can occur. In vertical or hanging installations, the product can fall down.

Appropriate measures must be taken in such installation configurations to protect against such an event (see also the Division Information Sheet on “Gravity-Loaded Axes” (No. 005 Edition 08/2012) of the Woodworking and Metalworking Division of the German statutory accident assurance association DGUV).

- ▶ The product must not under any circumstances be subjected to impermissible mechanical loads (for data, see product catalog).
- ▶ The product must never be used as a hand-support or step.
- ▶ Do not place any objects on the product without fixing them.

- ▶ Take note of the transport instructions on the packaging.
- ▶ Cables and wires must be routed safely and tidily so that they will not be damaged and no one can become entangled in them.
- ▶ Checks must be performed to ensure that all electrical connections are either used or covered.
- ▶ The product may only be put into service when it has been completely installed.
- ▶ It must be ensured that only persons authorized by the equipment user are granted access to the immediate operating zone of the product. This also applies when the product is at a standstill.
- ▶ It must be ensured that no cable connections, other connections or parts are disconnected while the system is energized and under pressure.
- ▶ After any work on the machine, reinstall the product in compliance with the instructions and regulations and check its function.
- ▶ The following standard is to be observed: DIN 637, Safety regulations for dimensioning and operation of Profiled Rail Systems with recirculating rolling elements.

## 2.5 Personal protective equipment

- ▶ When handling the product, personnel must wear appropriate protective equipment or clothing (e.g. safety shoes, gloves, etc.). All components of the personal protective equipment must be intact.

## 2.6 Duties and obligations of the user

The user of the product is responsible for complying with the appropriate safety precautions when using the product for the particular purpose envisaged by the user.

- ▶ It must be ensured that the product is operated only within the scope of the intended use as stated under ➡ “2.1 Intended use”.
- ▶ It must be ensured that the operating personnel is appropriately instructed at regular intervals.
- ▶ Any potential hazard zones must be indicated by signs.

The user is responsible for ensuring that safety devices and guards are in proper working order.

## 2.7 Safety devices and guards

- ▶ It must be ensured that all safety devices and guards are in perfect condition and are inspected regularly according to the manufacturer's instructions and in compliance with occupational safety regulations.
- ▶ Before starting up the product, it must be ensured that all safety devices and guards required for the product have been properly installed and are in full working order.

## 3 General notes on damage to product and property

The warranty applies exclusively to the as-delivered configuration.

- The warranty is rendered void in the case of faulty mounting, start-up and operation, as well as misuse and/or improper handling.
- The following notes apply to the use of single-axis and multiple-axis Linear Motion Systems.
  - ▶ All installation work must be performed with a high regard for cleanliness to avoid contamination that could lead to premature wear and malfunctioning of the product.
  - ▶ Before starting up the product, all seals and plug-and-socket connections must be checked for correct installation and intactness in order to prevent liquids and foreign matter from working their way into the product.
  - ▶ At critical ambient temperatures,  14 "Operating conditions" in the product instruction manual, the product must be allowed to acclimatize for several hours before start-up.
  - ▶ Do not disconnect plug-and-socket connectors or cover them with protective caps to ensure that no cleaning agent or detergent can work its way into the system.
  - ▶ Perform the specified maintenance work at the intervals stated in the product instruction manual (see table 1).

## 4 Scope of supply

**Table 4: Scope of supply**

<b>Runner Block</b>	<b>Guide Rail</b>
Runner Block with mounted Scanner	Guide Rail with scale
Lube nipples	Accuracy protocol for the scale
Instructions for IMS (R320103696)	Mounting hole plugs or cover strip
	Instructions for IMS (R320103696)
	Guide Rail leaflet (R320103695)

### 4.1 Accessories

See “IMS” catalog for accessories

## 5 Product description

### 5.1 Features

Please refer to the notes, technical data and descriptions in the “IMS” catalog.

## 5.2 Equipment description

The product consists of the following parts:

- |   |  |
|---|--|
| <b>1</b> Guide Rail   | <b>8</b> Scale incremental                                   |
| <b>2</b> Front seal   | <b>9</b> Scale protection: laser-welded stainless-steel band |
| <b>3</b> Support plate  | <b>10</b> Reference or absolute code sensor                  |
| <b>4</b> Scanner  | <b>11</b> Measuring sensor                                   |
| <b>5</b> Adapter plate (fixed to the Runner Block)                        | <b>12</b> Evaluation electronics                             |
| <b>6</b> Runner Block   | <b>13</b> Cable and connector                                |
| <b>7</b> Reference marks (IMS-I) or scale with absolute code band (IMS-A) | <b>14</b> Nameplate  |

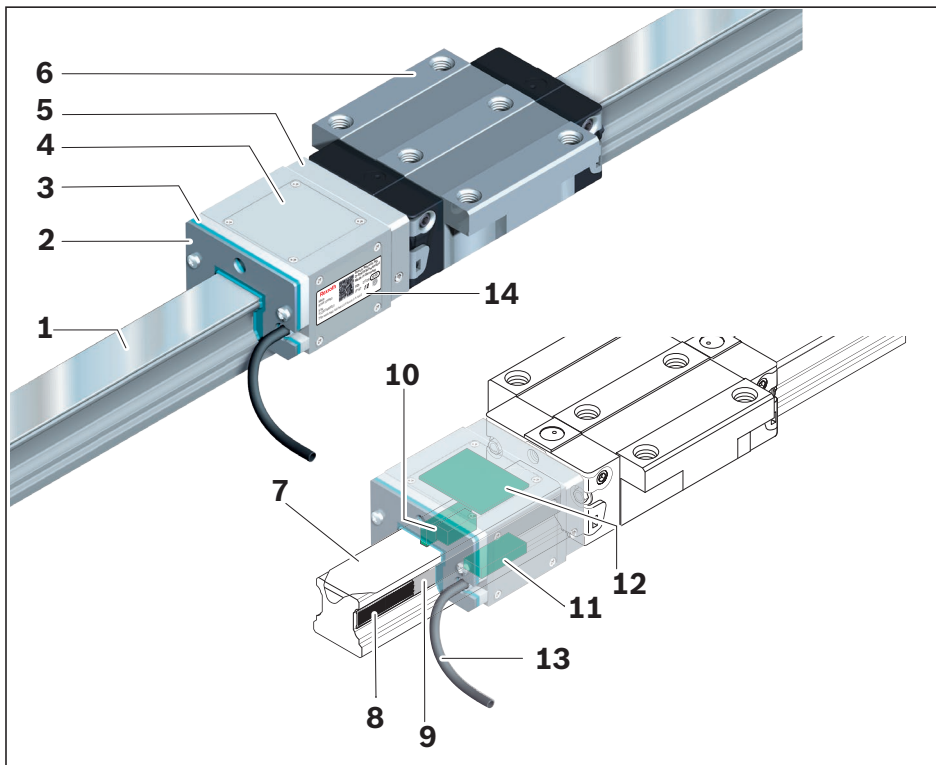

Fig. 1: Structural design of the product

## 5.3 Identification of the product

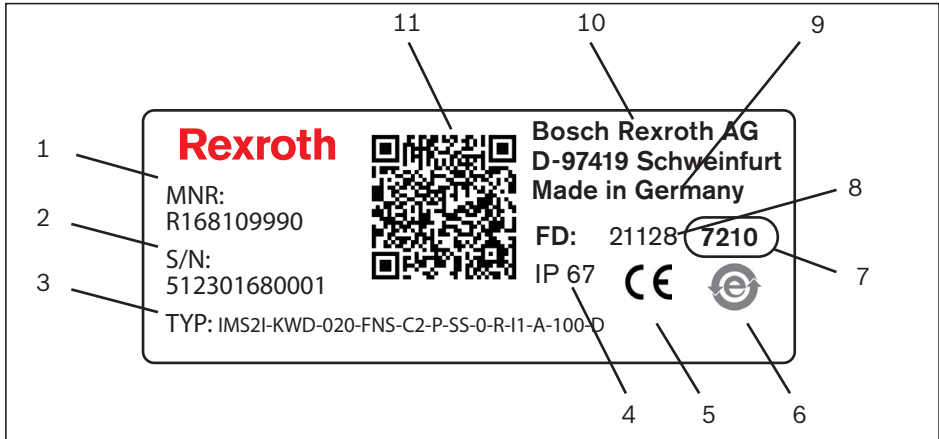

Fig. 2: Nameplate IMS-I (example)

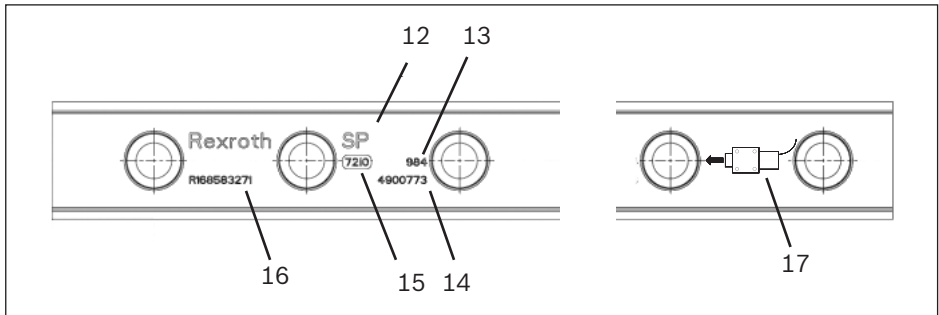

Fig. 3: Identification Guide Rail (example)

- |   |   |
|---|---|
| <b>1</b> Material number                  | <b>10</b> Company address                   |
| <b>2</b> Serial number                    | <b>11</b> QR code                           |
| <b>3</b> Type designation (40 characters) | <b>12</b> Accuracy class of the Guide Rail* |
| <b>4</b> Protection class                 | <b>13</b> Date of manufacture               |
| <b>5</b> CE marking                       | <b>14</b> Serial number                     |
| <b>6</b> China RoHS marking               | <b>15</b> Department/factory number         |
| <b>7</b> Department/factory number        | <b>16</b> Part number                       |
| <b>8</b> Date of manufacture              | <b>17</b> Rail end identification           |
| <b>9</b> Designation of origin            |   |

\* The accuracy class of the scale is shown on the accuracy protocol provided (scope of delivery)

### 5.3.1 Type designation

#### Example type designation

I	M	S	2	I	-	K	W	D	-
---	---	---	---	---	---	---	---	---	---

I	M	S	2	I	-	R	W	D	-
---	---	---	---	---	---	---	---	---	---

I	M	S	2	A	-	K	W	D	-
---	---	---	---	---	---	---	---	---	---

I	M	S	2	A	-	R	W	D	-
---	---	---	---	---	---	---	---	---	---

<b>IMS2</b>	<b>Integrated Measuring System Gen. 2</b>
-------------	---

<b>I</b>	<b>Incremental</b>
----------	--------------------

<b>A</b>	<b>Absolute</b>
----------	-----------------

<b>KWD</b>	<b>Ball Runner Block with Scanner</b>
------------	---------------------------------------

<b>RWD</b>	<b>Roller Runner Block with Scanner</b>
------------	---

0	2	0	-	F	N	S	-	C	2	-	P	-	S	S	-	R	-	R	-	I	1	-	A	-	1	0	0	-	D
1				2				3			4		5		6		7		8		9		10						11

1	Size
2	Format
3	Preload class
4	Accuracy class
5	Seal
6	Ball Chain
7	Scanner mounting side
8	Interface
9	Connector type
10	Cable length
11	Documentation

## 6 Transport and storage

Observe the operating conditions ➡ 14 and catalog.

### 6.1 Transporting the product

Take note of the Instructions for Profiled Rail Systems

### 6.2 Storage

#### NOTE

##### **Risk of damage due to incorrect storage!**

Potential corrosion of product parts.

- ▶ Store the product only in dry, roofed areas.
- ▶ Protect the product from humidity and corrosive agents.

## 7 Installation



IMS installation videos are available on YouTube. For more information, see the section “Service and support”.

### 7.1 Installation conditions

Observe the operating conditions ➡ 14 and catalog.

Dimensions and part numbers of the individual components ➡ Catalog

### 7.2 Installation position



#### WARNING

##### **Risk of product crashing down in vertical or slanting installations due to lack of arrestor devices!**

Severe personal injury or even death.

- ▶ In vertical or slanting installations, secure the product so that it cannot drop down.
- ▶ Do not stand within the hazard zone.
- ▶ Observe the Instructions for Profiled Rail Systems.

#### NOTE

##### **Risk of damage due to non-permissible loads!**

Damage to the product.

- ▶ Observe the Instructions for Profiled Rail Systems.



## 7.3 Mounting the IMS Guide Rails

### 7.3.1 Preparatory steps

 The rail end at which the Runner Block (with Scanner) is to be pushed on is identified with a durable marking (1) on the Guide Rail. If it is mounted in the wrong direction, the measuring system will not work.

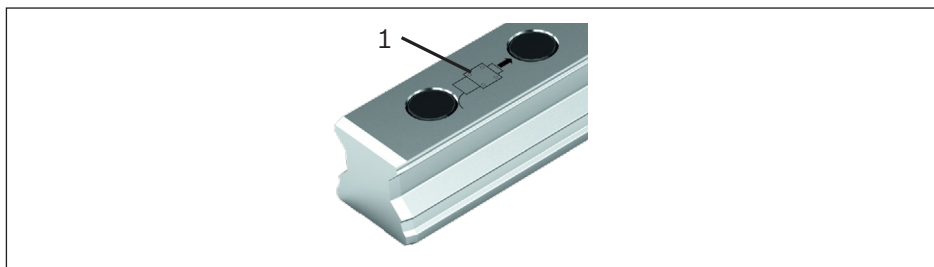



Fig. 4: **Preparatory steps**

- ▶ Before mounting the Guide Rail, the proper mounting orientation of the rail within the overall system must be verified. This can be done by checking against the design documents. This will ensure the “right” orientation of the reference edge on the Runner Block, ensuring that the Scanner on the Runner Block is in the right orientation in its final installed state!
- ▶ The Runner Block must be pushed on after the installation of the Guide Rail as shown in Fig. 4.
- ▶ Warning: when a cover strip is used, the mark (1) is covered and the push-on direction is no longer visible.

 Mark the push-on direction of the block in another suitable way.

### 7.3.2 Mounting the IMS Guide Rails

#### NOTE

#### Damage due to improper mounting!

Damage to the product.

- ▶ Always handle the Integrated Measuring System with great care!
- ▶ Observe the Instructions for Profiled Rail Systems.

Effects on the system accuracy of the measuring system.

- ▶ Mount the IMS Guide Rails as shown in Fig. 5.
- ▶ Do not exceed the maximum permitted tightening torques ➡ see relevant catalog.

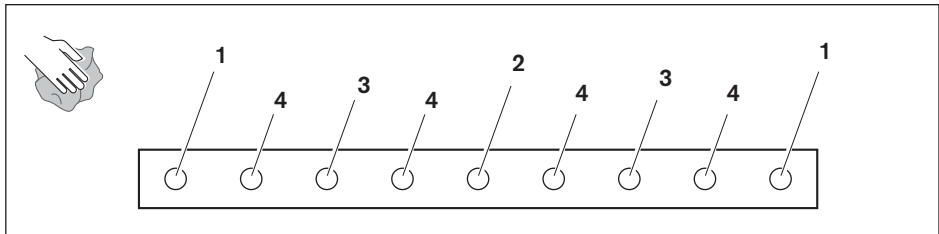

Fig. 5: Mounting the IMS Guide Rails

- ▶ For parallelism, vertical offset, strength ➡ see the relevant catalog
- ▶ Screw down the Guide Rails starting with the ends (1).
- ▶ Then screw down each successive screw at mid-point (2, 3, 4) between two already installed screws.
- ▶ Mount the Guide Rail cover strip or mounting hole plugs ➡ see relevant instructions. If necessary, “mark” the direction in which the Runner Block has to be pushed on (reuse the label).

## 7.4 Mounting the Runner Blocks

### **WARNING**

#### **Risk of injury due to shear points!**

Crushing and slicing of finger tips when moving over the mounting holes of the Guide Rail.

- ▶ Plug the mounting holes in the Guide Rail before pushing on the Runner Block.
- ▶ Observe the Instructions for Profiled Rail Systems.

### *NOTE*

#### **Damage due to improper mounting!**

Damage to the product.

- ▶ Always handle the Integrated Measuring System with great care!
- ▶ Observe the Instructions for Profiled Rail Systems.
- ▶ The transport lock must remain in the Runner Block until the block is pushed onto the Guide Rail! Otherwise, the rolling elements may fall out!
- ▶ Do not push on the Runner Blocks until the mounting holes in the Guide Rails have been plugged. If the holes are not plugged, the seals on the Runner Block will be damaged.
- ▶ Do not push a Runner Block with measuring system onto the Guide Rail with the Scanner first!
- ▶ Never push a Runner Block with measuring system onto standard rails, only onto IMS rails.

EN

### 7.4.1 Preconditions for proper mounting

- ▶ For composite Guide Rails with “sharp” transitions, only the Runner Block may be traversed over the joint.  
The Scanner must be completely on the IMS rail at all times. The joint area is not included in the measuring range.
- ▶ Do not apply any tension and pressure forces on the Scanner via the cable.
- ▶ Smallest cable bending radius (20 mm stationary); cable is not suitable for use as a drag chain.

## 7.4.2 Mounting the Runner Block

- ▶ Position the Runner Block with transport lock (1) on the Guide Rail.
- ▶ Push the Runner Block onto the rail ➡ Fig. 6
- ▶ Keep the transport lock (1) for later disassembly.

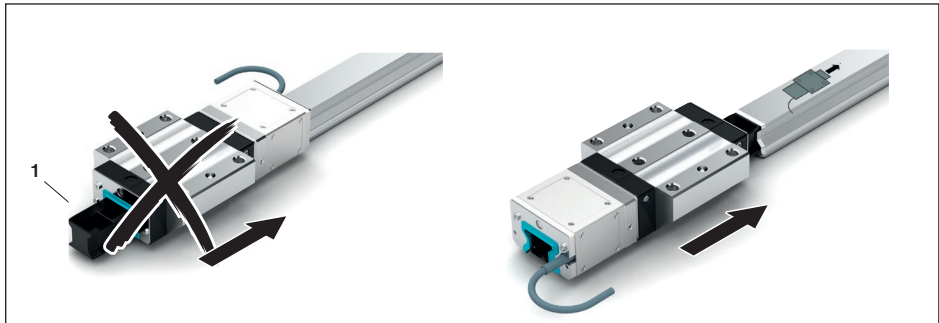

Fig. 6: Pushing the Runner Block onto the rail

## 8 Start-up

- ▶ See “IMS instructions for electrical interfaces R320103166”. These instructions are only available as a PDF document and can be found in the Bosch Rexroth media directory under [www.boschrexroth.com/mediadirectory](http://www.boschrexroth.com/mediadirectory)  
Search term: R320103166

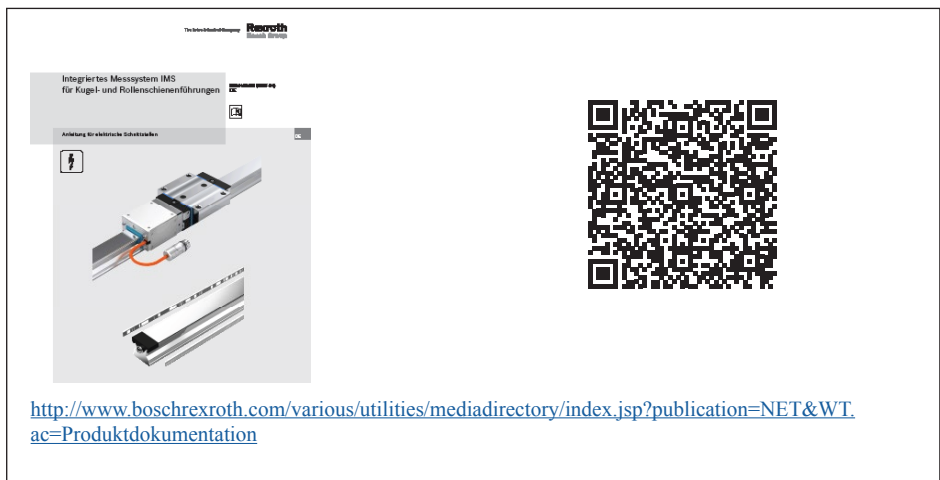

Fig. 7: Start-up

## 9 Operation

### **WARNING**

#### **Risk of injury due to moving parts.**

Limbs or extremities may be crushed.

- ▶ Do not attempt to grasp any moving parts while the system is in operation.
- ▶ Do not stand within the hazard zone.

### **CAUTION**

#### **Hot surfaces**

Risk of burns

- ▶ The Scanner and Runner Block may possibly heat up.
- ▶ Wear appropriate protective clothing or
- ▶ allow the system to cool down before beginning any maintenance work.

#### **Noise generation while in operation**

Risk of damage to hearing, deafness

- ▶ In case of excessive noise development, wear suitable ear protection.

### *NOTE*

#### **Insufficient lubrication!**

Damage to the product.

- ▶ While the equipment is in service, comply with the lubrication and maintenance intervals for ball and roller rail systems.
- ▶ Be sure to comply also with the operating conditions for the products.

- ▶ The accuracy of the IMS is only assured when the operating conditions are complied with and the unit has been properly installed.

# 10 Maintenance and repair

## 10.1 Cleaning and care

### NOTE

**Risk of damage due to the use of solvents and aggressive detergents!**

Degradation of seals and malfunction of the product.

- ▶ Use only a lint-free cloth to clean the product.
  
- ▶ Dirt can settle and encrust on Guide Rails, especially when these are not enclosed.
  
- ▶ To ensure that seals and cover strips retain their functionality, dirt must be removed at regular intervals.
  
- ▶ It is advisable to perform at least one full cleaning cycle over the entire travel path at least twice a day or every 8 hours at the latest.
  
- ▶ Before shutting down the machine, always perform a cleaning cycle.
  
- ▶ Check that the seals and plug-and-socket connections fit tightly to ensure that no moisture can penetrate the system during cleaning.

## 10.2 Lubrication/maintenance

The only maintenance required is regular lubrication of the Runner Block, and possibly the exchange of sealing elements.

The Scanner of the IMS is non-contacting and thus maintenance-free.

### WARNING

**Risk of injury due to moving parts.**

Limbs or extremities may be crushed.

- ▶ Do not attempt to grasp any moving parts while the system is in operation.
- ▶ Do not stand within the hazard zone.

- ▶ Always switch off the machine and apply all safety interlocks before commencing any maintenance work!
- ▶ Lubricate the ball and Roller Runner Blocks via the free lube fittings.  
    ▮ see relevant catalog
- ▶ All accessories used for scraping or wiping the Guide Rails must be checked at regular intervals and replaced if necessary.
- ▶ In environments with heavy contamination, it is advisable to replace all the parts directly exposed to such contamination.
- ▶ We recommend annual maintenance.
- ▶ Before using lubricants, read and take note of the corresponding material safety data sheets.

## NOTE

### **Risk of damage due to insufficient lubrication!**

Loss of performance and corrosion.

- ▶ Lubricate the product as specified in the relevant catalog.

### **Risk of insufficient lubrication due to use of wrong lubricants!**

Damage to the product.

- ▶ Use only recommended lubricants ▮ see relevant catalog.

### **Change in performance due to special operating conditions!**

Damage to the product.

- ▶ Before starting up the product under special operating conditions, please consult Bosch Rexroth AG. This applies especially to environments with glass fiber or wood dust, solvents, extreme temperatures, and for short-stroke applications.

## **10.2.1 Runner Block lubrication, lubrication intervals and lubricant quantities**

- ▶ See relevant catalog

# 11 Removal and replacement

## WARNING

### **Danger of uncontrolled movements due to lack of arrestor devices in vertical or slanting installations**

Severe personal injury or even death

- ▶ In vertical or slanting installations, secure the product so that it cannot drop down.
- ▶ Do not stand within the hazard zone.

## CAUTION

### **Risk of lubricant escape**

Contamination of soil and water

- ▶ Always use a collecting container

Risk of skin irritation

- ▶ Wear protective gloves

### **Hot surfaces**

Risk of burns

- ▶ The Scanner and Runner Block may possibly heat up.
- ▶ Wear appropriate protective clothing or
- ▶ allow the system to cool down before beginning any maintenance work.

### **Sharp edges**

Risk of injury

- ▶ Wear protective gloves

- ▶ Make sure the machine is secured and in a safe state before beginning to remove individual components.
- ▶ Safety interlocks must be provided to prevent inadvertent switching on of the machine or system part.
- ▶ The rail with scale and the Runner Block-Scanner assembly can be replaced separately (interchangeability).
- ▶ When a Runner Block is replaced, check the wear on the Guide Rail running tracks and replace the rail, if necessary.





## 11.1 Changing the front seal on the Scanner (sensor unit)

The front seal should be replaced directly on the Guide Rail. To do this, proceed as follows:



IMS installation videos are available on YouTube. For more information, see the section “Service and support”.

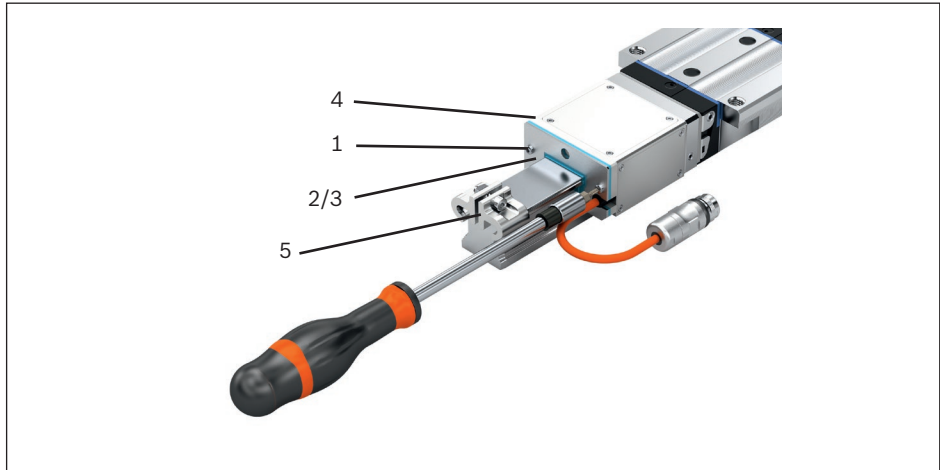

Fig. 8: Removing the front seal

1. Remove any cover strip protection (5)
2. Remove the two fixing screws (1) on the Scanner.
3. Remove the reinforcing plate (2) and the defective seal (3).
4. Replace the reinforcing plate (4) and center it on the Guide Rail.

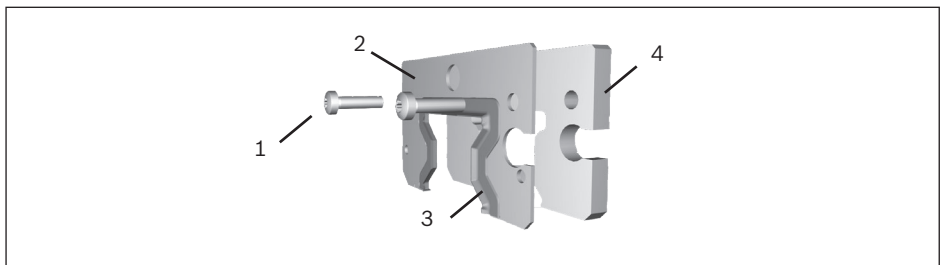

Fig. 9: Mounting the new front seal

5. Push the reinforcing plate (2) of the seal (3) onto the Guide Rail.
6. Align the front seal so that the sealing lips (6) fit snugly all around the Guide Rail.
7. Apply a medium strength threadlocker adhesive (e.g. Loctite 243) to the threads of the fixing screws, taking care to wet them thoroughly all round (7).
8. Tighten the screws with the specified tightening torque (table 5).  
The threadlocking adhesive acts as a sealant.  
If it is not properly applied, the sealing function may be lost.

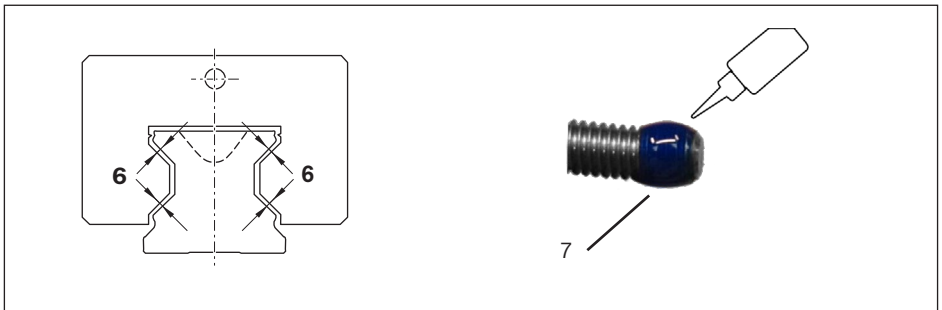



Fig. 10: Completing the mounting procedure

**Table 5: Tightening torques front seals**

Runner Block	Size	Bolt 	Tightening torque $M_A$ (Nm) 
Ball Runner Block	20 / 25 / 30 / 35	M3 x 12 Torx TX10	0.95 ... 1.05
	45	M4 x 14 Torx TX20	1.90 ... 2.10
Roller Runner Block	35	M3 x 10	0.95 ... 1.05
	45	M4 x 12	1.90 ... 2.10
	55	M5 x 12	2.80 ... 3.20
	65	M4 x 12	1.90 ... 2.10

## 11.2 Replacing the Scanner



IMS installation videos are available on YouTube. For more information, see the section “Service and support”.

### NOTE

#### Damage due to improper mounting/removal!

Damage to the product.

- ▶ Where possible, a Scanner should not be pushed onto the Guide Rail or removed from it without being attached to a Runner Block.

#### Disassembling the IMS in limited installation space

In a limited installation space, it is possible to loosen the Scanner and Runner Block on the rail and remove both carefully - be extremely careful in this case to prevent damage to the rail and sensors

- ▶ Disassembling/assembling the Scanner ➔ 11.2.1

The IMS allows the user to replace the Scanner if necessary during servicing. The procedure for replacing the Scanner will depend on its mounting location.

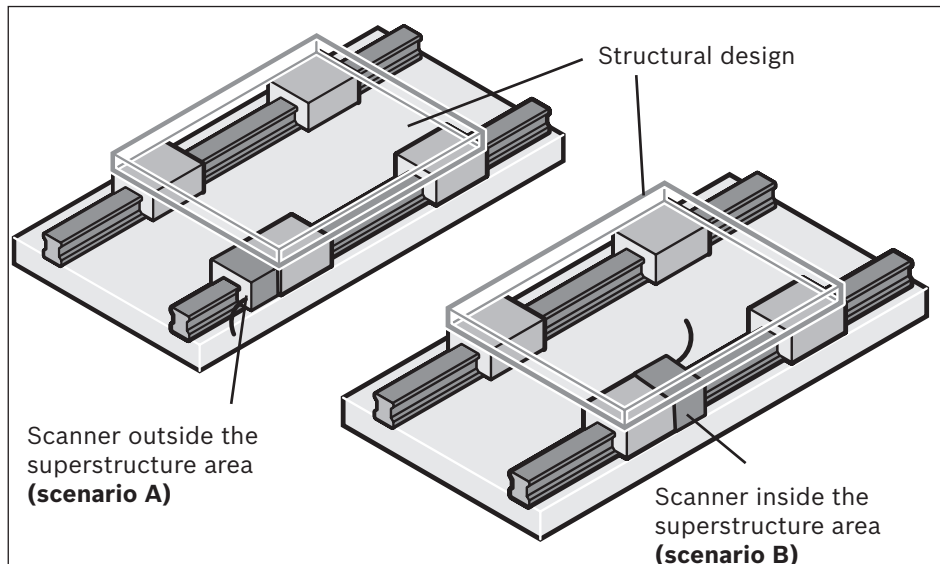

Fig. 11: Mounting location of Scanner

**Scenario A:**

- ▶ Move the IMS (with the superstructure) to the end of the Guide Rail until the Scanner is completely clear of the rail. The Runner Block itself must remain completely on the Guide Rail.

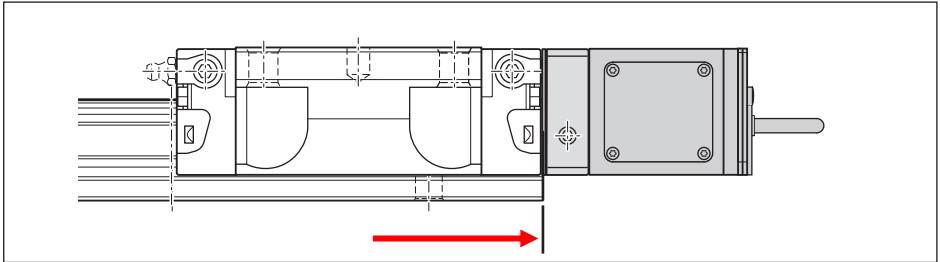

Fig. 12: Replacing the Scanner, scenario A

- ▶ Disassembling/assembling the Scanner ➔ 11.2.1

EN

**Scenario B:**

Remove the Runner Block and Scanner.

- ▶ Disconnect the Runner Block from the Scanner before removing it from the Guide Rail. ➔ 11.2.1.
- ▶ Carefully slide the Runner Block (without the Scanner) from the Guide Rail onto the transport lock (1).
- ▶ When removing the Scanner, make sure that no forces are exerted on the it.

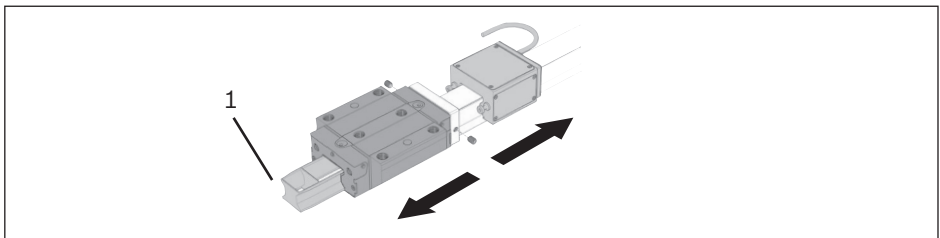

Fig. 13: Disconnecting the Runner Block and Scanner on the Guide Rail

Pushing on the Scanner and Runner Block

- ▶ The same level of caution must be used when pushing the Scanner on the Guide Rail as was used when removing it
- ▶ Slide the Runner Block onto the Guide Rail front the transport lock (1).
- ▶ Connect the Scanner with the measuring block ➔ 11.2.1.

### 11.2.1 Disassembling/assembling the Scanner

- ▶ The following disassembly or assembly steps can also be carried out if Runner Blocks and a Scanner are on the Guide Rail.
- ▶ Completely remove the set screws (1) on the right and left hand side of the adapter plate.
- ▶ Discard used set screws; do not reuse them.

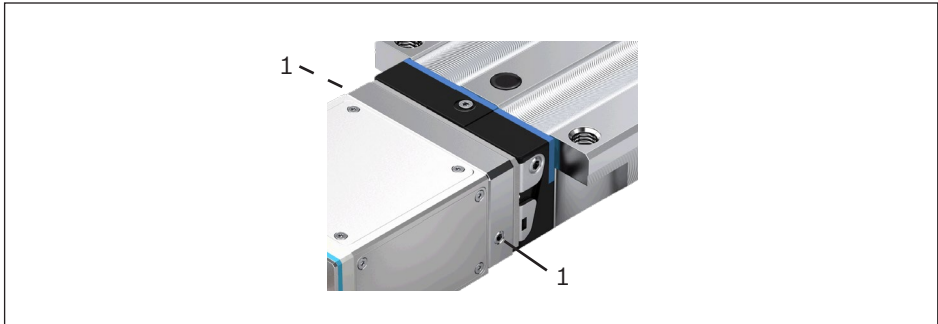

Fig. 14: Remove the set screws

- ▶ Carefully pull off the Scanner in a straight line, taking care not to tilt it. Do not use any levering tools or hammers, otherwise the precision fits or the locating screws could get damaged.
- ▶ Clean the adapter plate.
- ▶ Carefully push on the new Scanner until it is lying completely flush with the adapter plate.

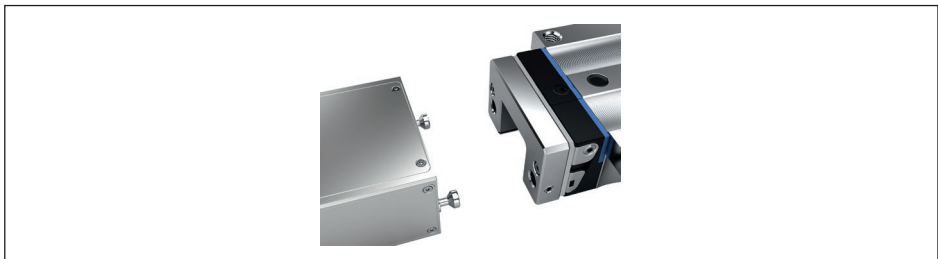

Fig. 15: Removing the Scanner

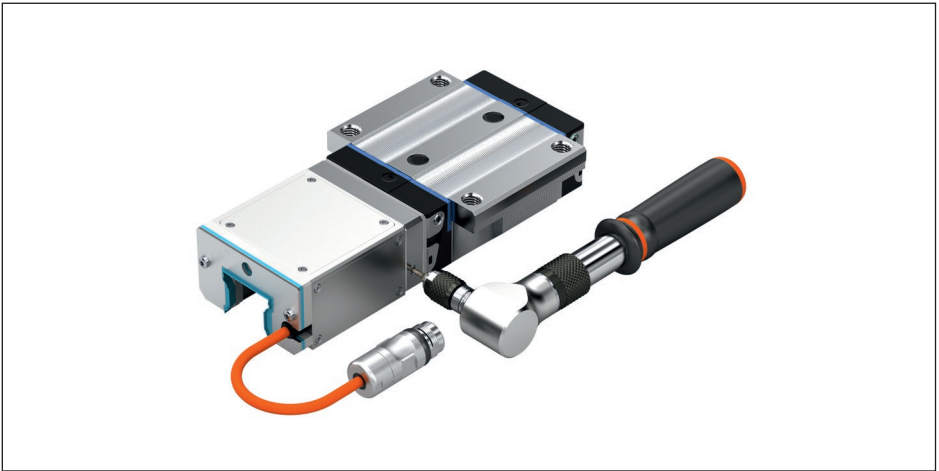



Fig. 16: **Screw the new Scanner to the Runner Block**

- ▶ Use new set screws to fasten the Scanner (do not exceed the specified tightening torques)

EN

**Table 6: Tightening torques set screws**

Runner Block	Size	Bolt 	Tightening torque (Nm) 
Ball Runner Block	20 / 25	M3x4 / Torx TX6	0.80 ... 0.90
	30 / 35	M5x5	2.80 ... 3.20
	45	M5x6	2.80 ... 3.20
Roller Runner Block	35 / 45	M5x5	2.80 ... 3.20
	55	M5x6	2.80 ... 3.20
	65	M5x6	2.80 ... 3.20

- ▶ Check that the Scanner is correctly seated
- ▶ Push the IMS back into the work zone.
- ▶ Re-reference the IMS and redefine the zero point if necessary, adjust the drive parameters (e.g. reset the “Absolute offset value”).

### 11.3 Putting into service again after disassembly

- ▶ When starting up the unit again, proceed as described in the section “Putting into service for the first time” ➡ 8.2

## 12 Disposal

The IMS contains a number of different materials: aluminum, steel, plastics, grease and electronic components.

The Scanner and the Runner Block have to be disposed of separately.

The Scanner must be disposed of as electronic waste, while the Runner Block is disposed of as scrap metal.

### *NOTE*

#### **Environmentally hazardous materials can pollute the environment if not disposed of properly!**

Environmental pollution.

- ▶ Collect any escaping lubricant and dispose of it correctly.
- ▶ The product and its components must be disposed of correctly and in compliance with all applicable national and international guidelines and regulations.

## 13 Technical data

Technical data ➡ “IMS” catalog.



## 14 Operating conditions

**Table 7: Operating conditions**

Symbol	Parameter	Unit	Min.	Nom.	Max.	Remark
<b>General</b>						
IP	Ingress protection level		IP67	-	-	Test acc. to standard: a.) with water b.) with Curtis S90 (10%)
$P_{abs}$	Ambient air pressure	hPa	800	1013	1200	
da/dt	Shock	m/s <sup>2</sup> / ms	-	-	500 / 11	½ sinus, 500 shocks, all axes
$a_{VIB}$	Vibration load	m/s <sup>2</sup>	-	-	100	55-2000 Hz, all axes, 10 cycles
	Operating hours	1000 h	80	-	-	
MTTF	Mean time to failure	a	100	-	-	
<b>Bearings</b>						
TT	Transport and storage temperature range	°C	-10	-	+70	
$\rho_T$	relative humidity when in storage	%	-	-	95	at 20 °C
<b>Operation</b>						
$V_{max}$	Travel speed	m/s	-	-	5 4	BRS RRS
$T_0$	Operating temperature range	°C	0	-	50	
$P_0$	Relative humidity when in operation	%	-	-	80	at 20 °C

- ▶ Interference immunity tested to EN 61326-1:2006
- ▶ Emitted interference, class B acc. to CISPR 11 (DIN EN 55011:2010-05 and FGN EN 61000-6-3)

## 15 Ordering replacement parts

### 15.1 Replacement Scanner

Replacement Scanners can be ordered separately. Select the replacement part you need according to the type designation.



Fig. 17: Scanner

**Rexroth** Bosch Rexroth AG  
 MNR: R168109990 D-97419 Schweinfurt  
 S/N: 512301680001 FD: 21128 (7210)  
 IP 67   
 TYP: IMS2-KWD-020-FNS-C2-P-SS-0-R-I1-A-100-D

To be stated when ordering

I	M	S	2	I	-	K	W	D	-	0	2	0	-	...	-	1	-	...
				1								8						

<b>I</b>	<b>Incremental</b>
<b>A</b>	<b>Absolute</b>
<hr/>	
<b>K</b>	<b>Ball Runner Block with Scanner</b>
<b>R</b>	<b>Roller Runner Block with Scanner</b>
<hr/>	
<b>1</b>	<b>Size</b>
<hr/>	
<b>8</b>	<b>Interface</b>

Fig. 18: Identification Scanner

IMS Scanners are delivered as standard with a cable length of 1 m and connector type A or connector type C (DRIVE-CLiQ) or connector type D (FANUC).

### 15.1.1 Scanner IMS-I

**Table 8: Scanner (IMS-I) for Ball Runner Blocks (material numbers)**

Interface Size	1Vpp (I1)	TTL 1 $\mu\text{m}$ (I2)	TTL 5 $\mu\text{m}$ (I3)	TTL 10 $\mu\text{m}$ (I4)
20	R051702171	R051702235	R051702240	R051702245
25	R051702172	R051702236	R051702241	R051702246
30	R051702173	R051702237	R051702242	R051702247
35	R051702174	R051702238	R051702243	R051702248
45	R051702175	R051702239	R051702244	R051702249

**Table 9: Scanner (IMS-I) for Roller Runner Blocks (material numbers)**

Interface Size	1Vpp (I1)	TTL 1 $\mu\text{m}$ (I2)	TTL 5 $\mu\text{m}$ (I3)	TTL 10 $\mu\text{m}$ (I4)
35	R052700628	R052700641	R052700644	R052700647
45	R052700629	R052700642	R052700645	R052700648
55	R052700630	R052700643	R052700646	R052700649

EN

### 15.1.2 Scanner IMS-A

**Table 10: Scanner (IMS-A) for Ball Runner Blocks (material numbers)**

Interface Size	SSI (variant S1)	HIPERFACE	DRIVE-CLiQ	FANUC
20	R051702925	R051702929	R051702934	R051703335
25	R051702926	R051702930	R051702935	R051703342
30	R051702927	R051702931	R051702936	R051703343
35	R051702908	R051702932	R051702937	R051703336
45	R051702928	R051702933	R051702938	R051703345

**Table 11: Scanner (IMS-A) for Roller Runner Blocks (material numbers)**

Interface Size	SSI (variant S1)	HIPERFACE	DRIVE-CLiQ	FANUC
35	R052700859	R052700867	R052700871	R052701057
45	R052700858	R052700868	R052700872	R052701058
55	R052700865	R052700869	R052700873	R052701059
65	R052700866	R052700870	R052700874	R052701060

## 15.2 Replacement Runner Block

Replacement Runner Blocks (with adapter plates) can be ordered separately. Select the replacement part you need according to the type designation.



Fig. 19: Runner Block

**Rexroth** Bosch Rexroth AG  
 MNR: R168109990 D-97419 Schweinfurt  
 S/N: 512301680001 Made in Germany  
 IP 67 FD: 21128 (7210)  
 TYP: IMS2-KWD-020-FNS-C2-P-SS-0-R-I1-A-100-D

To be stated when ordering

I	M	S	2	I	<b>K</b>	W	D	-	0	2	0	-	F	N	S	-	...	-	<b>R</b>	-	...
									1				2						7		

<b>K</b>	<b>Ball Runner Block</b>
<b>R</b>	<b>Roller Runner Block</b>

<b>1</b>	<b>Size</b>
<b>2</b>	<b>Format</b>
<b>7</b>	<b>Scanner mounting side</b>

Fig. 20: Identification Runner Block

## 15.2.1 Replacement Ball Runner Block

Replacement Runner Blocks are supplied in the version  
IMS2x – KWD – .. – C2 – \* – SS – 0 – ..

\* P for slimline Runner Blocks (SXX), SP for flanged Runner Blocks (FXX)

**Table 12: KWD with adapter plate, Scanner mounting side right (R) (material numbers)**

Format Size	FNS	FLS	SNS	SLS	SNH	SLH
20	R051702251	R051702256	R051702261	R051702266	-	-
25	R051702252	R051702257	R051702262	R051702267	R051702272	R051702277
30	R051702253	R051702258	R051702263	R051702268	R051702273	R051702278
35	R051702254	R051702259	R051702264	R051702269	R051702274	R051702279
45	R051702255	R051702260	R051702265	R051702270	R051702275	R051702280

**Table 13: KWD with adapter plate, Scanner mounting side left (L) (material numbers)**

Format Size	FNS	FLS	SNS	SLS	SNH	SLH
20	R051702281	R051702286	R051702291	R051702296	-	-
25	R051702282	R051702287	R051702292	R051702297	R051702302	R051702307
30	R051702283	R051702288	R051702293	R051702298	R051702303	R051702308
35	R051702284	R051702289	R051702294	R051702299	R051702304	R051702309
45	R051702285	R051702290	R051702295	R051702300	R051702305	R051702310

EN

## 15.2.2 Replacement Roller Runner Blocks

Replacement Runner Blocks are supplied in the version  
IMS2x – RWD – .. – C2 – S – SS – 0 – ..

**Table 14: RWD with adapter plate, Scanner mounting side right (R) (material numbers)**

Format Size	FNS	FLS	SNS	SLS	SNH	SLH
35	R052700663	R052700666	R052700669	R052700672	R052700675	R052700678
45	R052700664	R052700667	R052700670	R052700673	R052700676	R052700679
55	R052700665	R052700668	R052700671	R052700674	R052700677	R052700680
65	R052700875	R052700876	R052700877	R052700878	R052700879	R052700880

**Table 15: RWD with adapter plate, Scanner mounting side left (L) (material numbers)**

Format Size	FNS	FLS	SNS	SLS	SNH	SLH
35	R052700681	R052700684	R052700687	R052700690	R052700693	R052700696
45	R052700682	R052700685	R052700688	R052700691	R052700694	R052700697
55	R052700683	R052700686	R052700689	R052700692	R052700695	R052700698
65	R052700881	R052700882	R052700883	R052700884	R052700885	R052700886

### 15.2.3 Scanner front seal

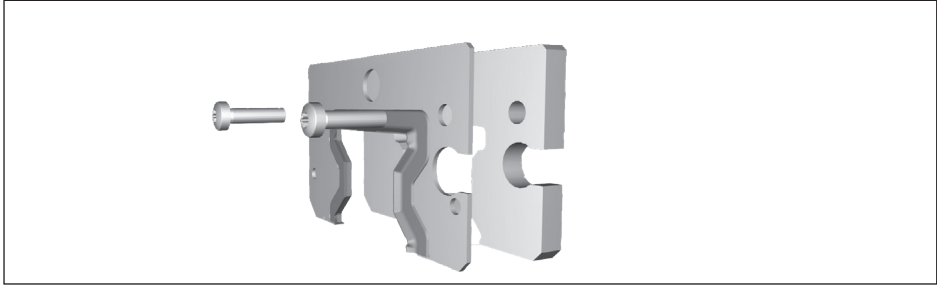

Fig. 21: Front seal<sup>1)</sup>

**Rexroth** **Bosch Rexroth AG**  
 D-97419 Schweinfurt  
 Made in Germany

MNR: R168109990  
 S/N: 512301680001  
 TYP: IMS2-KWD-020-FNS-C2-P-55-0-R11-A-100-D

FD: 21128 (7210)  
 IP 67

To be stated when ordering

I	M	S	2	I	-	K	W	D	-	0	2	0	-	...
										1				

**K**      **Ball Runner Block**

**R**      **Roller Runner Block**

---

<b>1</b>	<b>Size</b>
----------	-------------

Fig. 22: Identification front seal

**Table 16: Scanner front seal for Ball Runner Blocks (material numbers)**

Size	
<b>20</b>	R1684 800 20
<b>25</b>	R1684 200 20
<b>30</b>	R1684 700 20
<b>35</b>	R1684 300 20
<b>45</b>	R1684 400 20

**Table 17: Scanner front seal for Roller Runner Blocks (material numbers)**

Size	
<b>35</b>	R1884 300 20
<b>45</b>	R1884 400 20
<b>55</b>	R1884 500 20
<b>65</b>	R1884 600 20

1) Scope of delivery: Front seal, support plate and fixing screws.

## 16 Troubleshooting and fault clearance

### 16.1 General procedure for identifying faults

Fault	Possible cause	Remedy
<b>The IMS is not transmitting signals</b>	Scanner was slid onto the Guide Rail the wrong way around.	Check Runner Block orientation relative to rail ➡ 7.3.
		Remove Runner Block.
		Turn Runner Block around and slide it back onto the rail ➡ 7.4.
	Plug-and-socket connections no properly tightened/seated.	Check plug-and-socket connections <sup>1)</sup> .
	Supply voltage at Scanner is too low.	Check power supply and adjust if necessary <sup>1)</sup> .
	Extension cable is too long.	Adapt the power supply <sup>1)</sup> .
Increase the cable cross-section <sup>1)</sup> .		
Shorten the cable length <sup>1)</sup> .		
<b>Reference signals are not recognized by the controller/control unit</b>	Plug-and-socket connections no properly tightened/seated.	Check plug-and-socket connections <sup>1)</sup> .
	Incorrect parameter set for evaluating the reference marks.	Check control parameters <sup>1)</sup> .
<b>Absolute dimension is incorrectly calculated</b>	Incorrect parameters set, e.g. incorrect absolute offset value or incorrect pitch periods.	Check control parameters. Correct absolute offset value. Enter correct pitch period <sup>1)</sup> .
<b>Control is unstable</b>	Positive feedback in control loop. Encoder inversion activated. Motor phases interchanged.	Check control parameters. Check wiring <sup>1)</sup> .

<b>Fault</b>	<b>Possible cause</b>	<b>Remedy</b>
<b>Absolute accuracy of the system not achieved</b>	Incorrect bolting of the guide unit, mounting not according to instructions.	Mount the rail according to the instructions. Observe the bolting sequence ►► 7.3.
	Specifications for parallelism, flatness, bolting, strength of the linear guide not complied with.	Install components according to mounting instructions. Follow the notes ►► 7.3.
<b>Sensor is touching the rail</b>	Excessive load on the Runner Block or the Scanner.	Take note of the catalog information regarding max. load and reduced load capacity.
		Rule out any load on the Scanner due to cable bend!
	Check load on the Scanner due to other mechanical components!	
<b>Resistance to environmental influences not assured</b>	Specifications for parallelism, flatness, bolting, strength of the linear guide not complied with.	Install components according to mounting instructions. Follow the notes.
		Contamination too high at the operating location.
	Mechanical load on the Runner Block too great.	Take note of the catalog information regarding max. load and reduced load capacity.
<b>Function not assured at maximum cable length</b>	Failure to comply with defined maximum length and type of extension cable.	Use only original extension cable <sup>1)</sup> .
	Supply voltage is outside tolerance range.	Check power supply and adjust if necessary <sup>1)</sup> .

1) For more information, see "Instructions for electrical interfaces" R320103166.



## 17 Service and support

### 17.1 Installation videos



IMS installation videos are available on YouTube:

[www.boschrexroth.com/how-to-LT](http://www.boschrexroth.com/how-to-LT)



EN

### 17.2 Service hotline

Our service hotline will be happy to assist you in any way they can.

You can reach us by phone at:

+49 (0) 9352 40 50 60

Bosch Rexroth AG  
Linear Motion and  
Assembly Technologies  
Ernst-Sachs-Straße 100  
97424 Schweinfurt, Germany  
Tel. +49 9721 937-0  
Fax +49 9721 937-275  
[www.boschrexroth.com](http://www.boschrexroth.com)

Subject to amendments  
Printed in Germany  
R320103262 (2020.07)