



Instructions manual

Series 6000
Variable area flowmeter



The art of measuring

PREFACE

Thank you for choosing a product from Tecfluid S.A.

This instruction manual allows the installation, configuration, programming and maintenance. It is recommended to read it before using the equipment.

WARNINGS

- This document shall not be copied or disclosed in whole or in any part by any means, without the written permission of Tecfluid S.A.
- Tecfluid S.A. reserve the right to make changes as deemed necessary at any time and without notice, in order to improve the quality and safety, with no obligation to update this manual.
- Make sure this manual goes to the end user.
- Keep this manual in a place where you can find it when you need it.
- In case of loss, ask for a new manual or download it directly from our website www.tecfluid.com Downloads section.
- Any deviation from the procedures described in this instruction manual, may cause user safety risks, damage of the unit or cause errors in the equipment performance.
- Do not modify the equipment without permission. Tecfluid S.A. are not responsible for any problems caused by a change not allowed. If you need to modify the equipment for any reason, please contact us in advance.

TABLE OF CONTENTS

SERIES 6000

1	INTRODUCTION	5
2	WORKING PRINCIPLE	5
3	MODELS	6
4	RECEPTION	6
5	INSTALLATION	6
5.1	Valves	7
5.2	Filters	7
6	OPERATION	7
6.1	Gas flow measurement	7
6.2	Liquid flow measurement	8
7	FLOW READING	9
8	AMD LIMIT SWITCH	10
8.1	Introduction	10
8.2	Operation	10
8.3	Switching point adjustment	10
8.4	Electrical connection	11
8.5	Mounting	11
9	AMM LIMIT SWITCH	12
9.1	Introduction	12
9.2	Operation	12
9.3	Switching point adjustment	12
9.4	Electrical connection	13
9.5	Mounting	13
10	AMR LIMIT SWITCH	14
10.1	Introduction	14
10.2	Operation	14
10.3	Switching point adjustment	14
10.4	Electrical connection	15

11	TMUR RESISTIVE SENSOR	16
	11.1 Introduction	16
	11.2 Operation	16
	11.3 Models	16
	11.4 Electrical connection	16
12	MAINTENANCE	17
	12.1 Series 6000	17
	12.1.1 Non-guided float model	17
	12.1.2 Guided float model	18
	12.2 Potential problems with the measuring tube	19
	12.2.1 Jammed float	19
	12.2.2 Damaged float	19
	12.3 AMD limit switch maintenance	19
	12.3.1 Electrical verification	19
	12.4 AMM limit switch maintenance	20
	12.5 AMR limit switch maintenance	21
13	TECHNICAL CHARACTERISTICS	21
	13.1 Series 6000	21
	13.2 AMD limit switch	22
	13.3 AMM limit switch	22
	13.4 AMR limit switch	22
14	SAFETY INSTRUCTIONS	23
	14.1 Pressure equipment directive	23
	14.2 Certificate of conformity TR CU (EAC marking)	23
15	ADDITIONAL INSTRUCTIONS FOR THE ATEX VERSION	24
	15.1 Non-metallic parts	24
16	FLOW RANGES	25
17	DIMENSIONS	26
18	EQUIVALENCE CURVES	30

SERIES 6000

1 INTRODUCTION

The series 6000 are flowmeters for liquids and gases.

They are very compact instruments.

They have local flow rate indication with scales calibrated in l/h, l/min, %, etc.

They can fit switches that allow to detect a specific flow rate and provide an alarm signal to a remote device. They can also fit a resistive sensor with a 4-20 mA transmitter proportional to flow rate.

2 WORKING PRINCIPLE

Based on variable area principle.

The flowmeter consists of a borosilicate glass tapered tube and a float inside it. The force of the fluid pushes the float to an equilibrium point. The area obtained between the float and the tube is proportional to the flow rate.

The equilibrium point depends on:

- E = Force of the fluid flow
- F_f = Weight of the float
- A_l = Free area of flow

where:

($A_l = A_c$, tube area - A_f , float area)

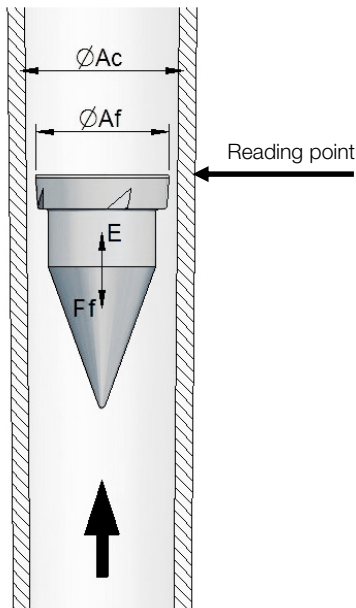

3 MODELS

Depending on the connection:

- 6001 BSP or NPT thread, PVC solvent socket or EN 1.4404 connections for welding
- 6002 EN 1092-1 or ASME B16.5 flanges. Other flange standards on request
- 6011 DIN 11851 sanitary coupling
- 6013 Clamp ISO 2852, TRI-CLAMP ® sanitary coupling
- 6015 SMS 1145 sanitary coupling

Depending on the construction materials:

- 6000-Fe All components in galvanized and coated steel
- 6000-SS Wetted parts in EN 1.4404 (AISI 316L). Other components in galvanized and coated Steel
- 6000-FULLY SS All components in EN 1.4404 (AISI 316L), except frame in EN 1.4301 (AISI 304)
- 6000-PVC Wetted parts in PVC. Other components in galvanized and coated steel
- 6000-PP Wetted parts in PP. Other components in galvanized and coated steel
- 6000-PTFE Wetted parts in PTFE. Other components in galvanized and coated steel
- 6000-PVDF Wetted parts in PVDF. Other components in galvanized and coated steel

4 RECEPTION

The series 6000 flowmeters are supplied conveniently packaged for their protection during transportation and storage, together with their instructions manual for installation and operation.

The instruments are supplied tested in our flow rigs, ready for installation and service.

Before installing the flowmeter, remove all the blocking elements.

The flowmeter has transparent plastic protections in the front and back, that allow to see the float position and the scale and protect the operator in case of accidental breakage of the glass tube.

Turning the instrument carefully upside down, check that the float moves freely.

5 INSTALLATION

Flowmeters must be installed in a completely vertical position and with upwards flow direction.



It is important that the position is completely vertical given that deviations of about 5° can produce errors of about 10% of the readings.

The fluid inlet must always be at the bottom of the flowmeter (minimum scale value).

The fluid outlet must always be at the top of the flowmeter (maximum scale value).

Do not forget to fit the gaskets between the union pieces and the pipe.

5.1 Valves

In cases where the operating fluid is a liquid, the valve should be mounted at the inlet (bottom) of the meter (see point 6.2).

If the fluid to be measured is a gas, the valve position will depend on the calibrating pressure of the instrument (see point 6.1).



Valves should always be opened slowly to avoid water hammers.

5.2 Filters

The installation of a filter before the instrument is recommendable, this will avoid possible obstructions and breakdowns in the measuring system.

The mesh of the filter should be of maximum 200 microns.

6 OPERATION

Once the meter is installed, the regulating valve should be opened slowly. The fluid flow will move the float.



Any variations of working conditions with respect to those when calibrated can induce reading errors.

6.1 Gas flow measurement

The working pressure and temperature are of maximum importance for correct gas measurement as they directly affect the scale readings.

For example, if a meter is calibrated at 2 bar gauge and the working pressure is 1 bar gauge there will be an error of about 22%.

In the same way, if working temperature does not match calibrating temperature, errors will be induced in the flow rate readings.

In applications of gas flow measurement where the calibrating pressure of the instrument corresponds to the inlet pressure, being higher than the atmospheric pressure, the regulating valve must be installed downstream of the flowmeter. Thus, it is ensured that the instrument works at calibrating pressure and a back pressure that keeps the float in equilibrium is obtained.

The flow should be adjusted by means of the regulating valve, while keeping the shut off valve fully open.

If the regulation is done using the shut off valve, in open circuits or at low gas flow in the meter, the gas will expand which will sharply diminish its density, providing very serious reading errors.

If the flow is regulated by the shut off valve, the float usually experiences an oscillating movement which produces a shut off action until sufficient pressure is gained to overcome its weight. The sudden fall of pressure, when the gas escapes, will make it fall. This cycle is repeated generating an oscillating measurement (resonance).

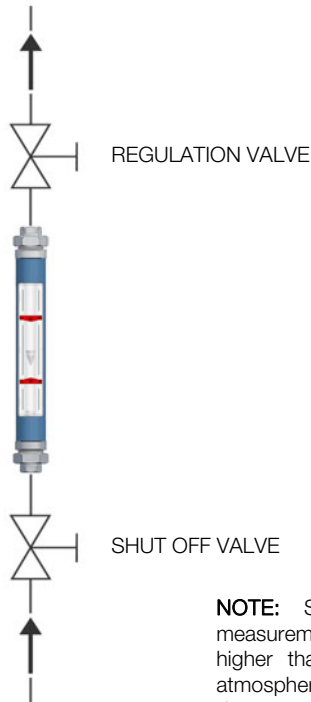

NOTE: Scheme valid for gas flow measurement applications with a pressure higher than atmospheric. For gases at atmospheric pressure, turn valves upside down.

In applications where the gas outlet is at atmospheric pressure, install the regulating valve upstream of the flowmeter if the flowmeter was calibrated at atmospheric pressure. The shut off valve is then installed downstream of the flowmeter and it should be fully open.

The valve opening procedure should be as following:

- With the regulating valve closed, fully open the shut off valve.
- Gradually open the regulating valve until the desired flow rate.

And for closing:

- Close the regulating valve gradually until zero flow rate.
- Fully close the shut off valve to isolate the flowmeter.

Operating in a different way may involve water hammers that can damage the flowmeter reading or generate flow reading instabilities.

6.2 Liquid flow measurement

When measuring liquids the regulating valve should be installed as shown in the following figure.

Being the shut off valve partially open, open the regulating valve slowly until the float shows a low flow rate on the scale. Then also open the shut off valve slowly in order to get rid of the air and then progressively fully opened.

The required flow rate is then regulated by using the regulating valve.

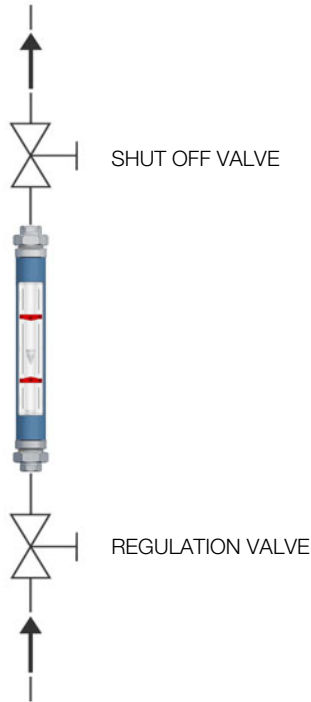

Close the valves during work stops at the end of the working day in order to avoid sudden surges when started up. If the float hits the stops sharply this could cause damage to the meter.

7 FLOW READING

The float position determines the flow rate on the scale.

Depending on the type of float, the reading should be taken at the height given in the following figure.

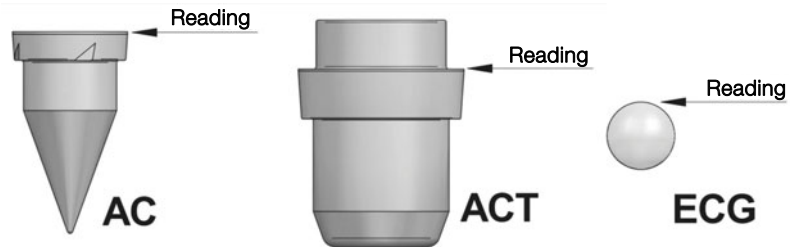

8 AMD LIMIT SWITCH

8.1 Introduction

The AMD limit switch can be used to generate an alarm or an operation when the flow rate that the instrument is measuring reaches a preset value. It is a bi-stable limit switch.

It consists of a NAMUR slot type inductive sensor, that is actuated by the float, by means of a vane that changes its position from one detection position to the other.

8.2 Operation

When the float passes through the point where the limit switch is positioned, it changes the state of the inductive sensor, and therefore the output state. This is maintained until the float passes in the opposite direction by the point where the switch is, returning again to the previous state.

As an optional element, a NAMUR amplifier with a switching relay as an output element can be supplied.

8.3 Switching point adjustment

Loosen the nuts (D).

Move the limit switch to the desired height on the scale.

Tighten the nuts (D) again.

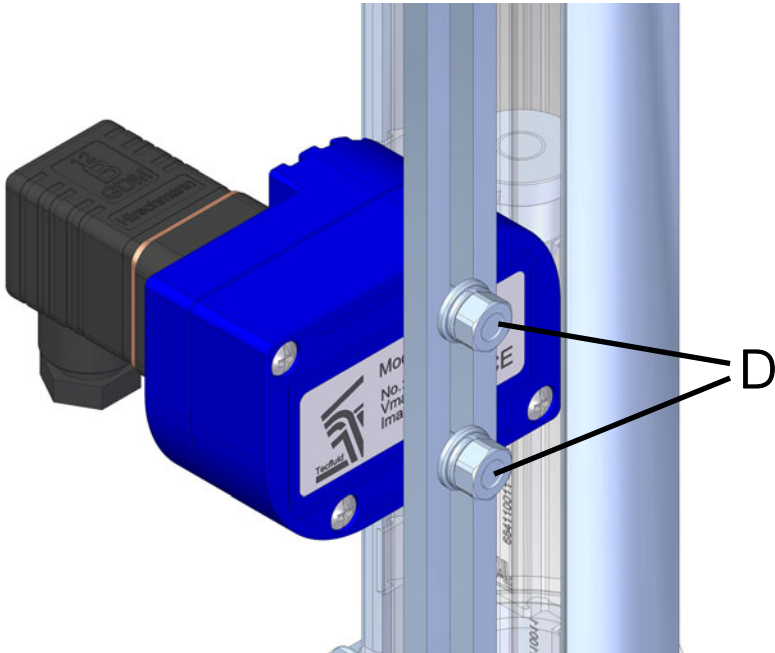

The position of the reading point of the float with reference to the switching point can vary from one type of float to another. If it is the first time that the switching point is adjusted, with the float in a stable position, slide the limit switch along the guide until the inductive sensor changes its state.

8.4 Electrical connection

For the electrical installation it is recommended to use multiple conductor cables, and not single cables, in order to guarantee the cable gland will stay watertight. The connector has a PG9 cable gland for cables with outer diameters between 4.5 mm and 7 mm. The numbering of the terminals is the following:

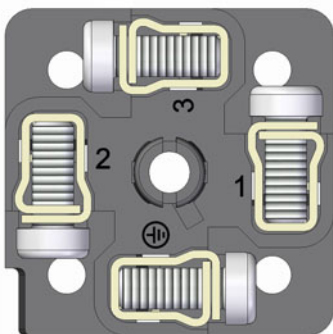

In the female connector (A):

- Terminal 1: Negative (Blue sensor cable)
- Terminal 2: Positive (Brown sensor cable)
- Terminal 3: Not connected
- Earth terminal: Earth

8.5 Mounting

Once the electrical connection has been made and the cable gland has been tightened, mount the female connector (A) on the male base (C), placing the seal (B) between the two pieces.

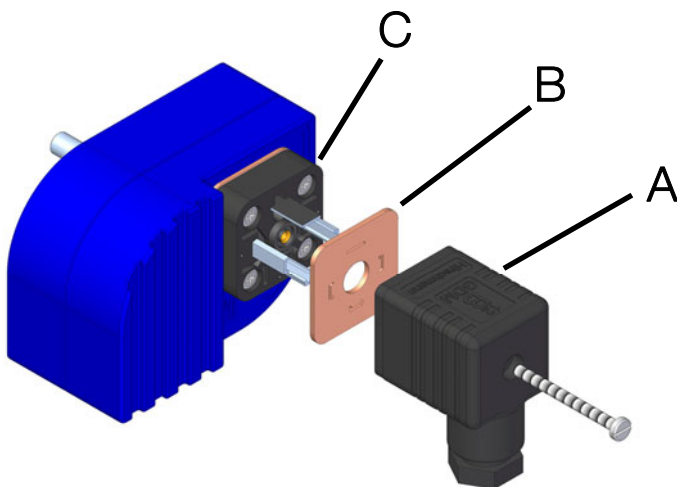

9 AMM LIMIT SWITCH

9.1 Introduction

The AMM limit switch can be used to generate an alarm or an operation when the flow rate that the instrument is measuring reaches a preset value. It is a bi-stable SPDT limit switch.

It consists of a micro-switch that is actuated by the magnetic field of the float, by means of a cam that pushes the micro-switch lever.

9.2 Operation

When the float passes through the point where the limit switch is positioned, it changes the state of the micro-switch, and therefore the output state. This is maintained until the float passes in the opposite direction by the point where the switch is, returning again to the previous state.

9.3 Switching point adjustment

Loosen the nuts (D).

Move the limit switch to the desired height on the scale.

Tighten the nuts (D) again.

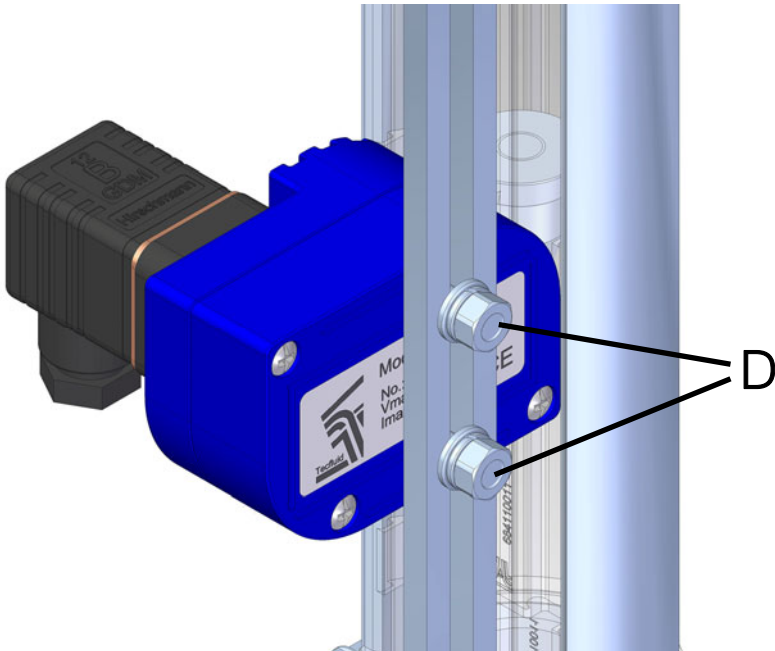

The position of the reading point of the float with reference to the switching point can vary from one type of float to another. If it is the first time that the switching point is adjusted, with the float in a stable position, slide the limit switch along the guide until the micro-switch changes its state.

9.4 Electrical connection

For the electrical installation it is recommended to use multiple conductor cables, and not single cables, in order to guarantee the cable gland will stay watertight. The connector has a PG9 cable gland for cables with outer diameters between 4.5 mm and 7 mm. The numbering of the terminals is the following:

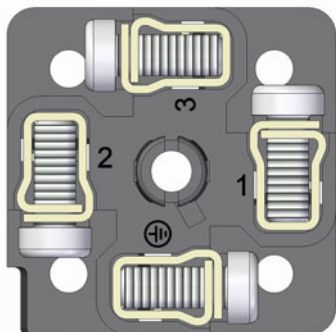

In the female connector (A):

- Terminal 1: Common
- Terminal 2: NO (Normally open)
- Terminal 3: NC (Normally closed)
- Earth terminal: Earth

9.5 Mounting

Once the electrical connection has been made and the cable gland has been tightened, mount the female connector (A) on the male base (C), placing the seal (B) between the two pieces.

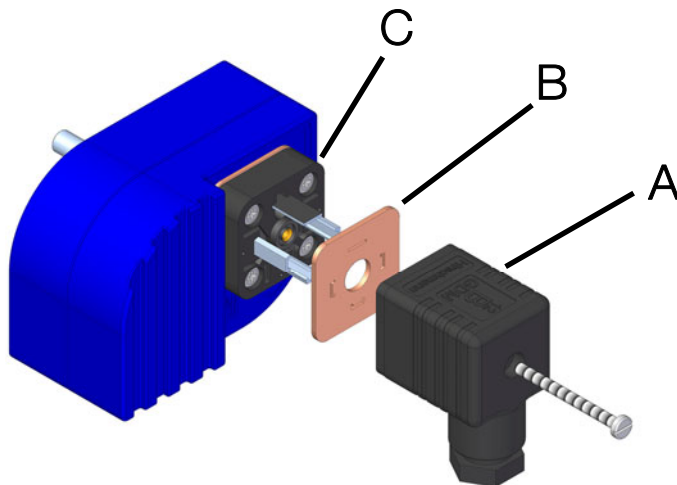

10 AMR LIMIT SWITCH

10.1 Introduction

The AMR limit switch can be used to generate an alarm or an operation when the flow rate that the instrument is measuring reaches a preset value. It is a bi-stable SPST limit switch.

It consists of a reed sensor that is actuated by the magnetic field of the float.

The limit switch can be supplied as a normally open switch when the float is below the switching point (PT-AMR NA), or as a normally closed switch in the same conditions (PT-AMR NC).

10.2 Operation

When the float passes through the point where the limit switch is positioned, it changes the state of the reed sensor, and therefore the output state. This is maintained until the float passes in the opposite direction by the point where the switch is, returning again to the previous state.

10.3 Switching point adjustment

To hold the limit switch to the frame protection, the AMR limit switch has a DIN 315 type screw.

Loosen the screw and clamp the limit switch on the guide of the rear plastic protection.

The position of the reading point of the float with reference to the switching point can vary from one type of float to another. If it is the first time that the switching point is adjusted, with the float in a stable position, slide the limit switch along the protection until the reed switch changes its state.

Mark the position of the reading point of the float on the limit switch and then situate this mark at the required switching height on the scale.

Tighten the clamping screw.

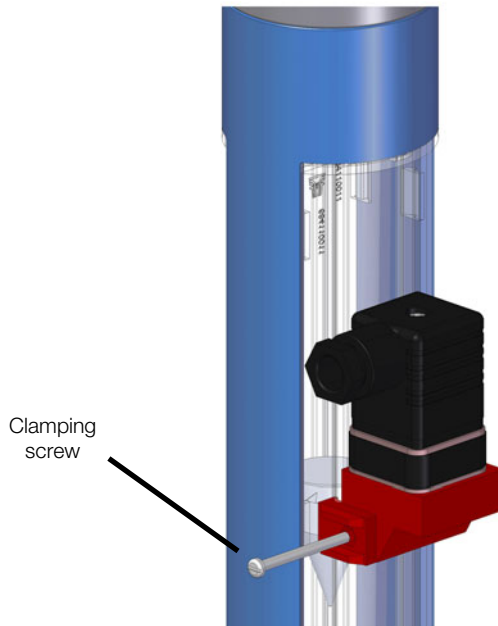

10.4 Electrical connection

For the electrical installation it is recommended to use multiple conductor cables, and not single cables, in order to guarantee the cable gland will stay watertight. The connector has a PG9 cable gland for cables with outer diameters between 4.5 mm and 7 mm. The numbering of the terminals is the following:

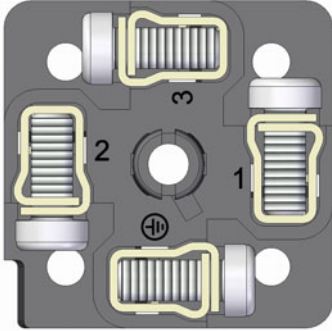

In the female connector:

Terminal 1:	Reed contact
Terminal 2:	Reed contact
Terminal 3:	Not connected
Earth terminal:	Not connected

Make sure that the contact rating is not exceeded. If high loads are to be switched, use an auxiliary relay.

When using inductive loads, such as relays or solenoid valve coils, surge arresters should be installed to protect the reed contacts.

With a DC supply, a diode should be connected as shown.

For an AC supply, a RC circuit can be used as shown, although a varistor (VDR) is better and is easier to select the right value. The VDR should have a breakdown voltage greater than 1.5 times the rms voltage. The standard varistor ratings specify the rms working voltage for the varistor, for example a S05K25 varistor will be for 25 V_{rms} working and will have a breakdown voltage of 39 V at 1 mA.

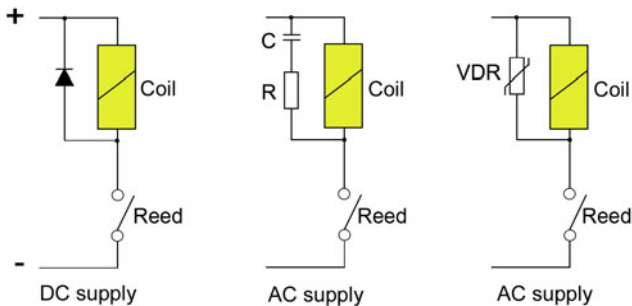

The electrical installation should provide a fuse or circuit breaker to protect the reed switch from overloads.

When installing the connector, make sure that the cable gland (A) closes over the cable and that the connector (B) with the rubber seal (C) is well screwed down to maintain the IP65 rating.

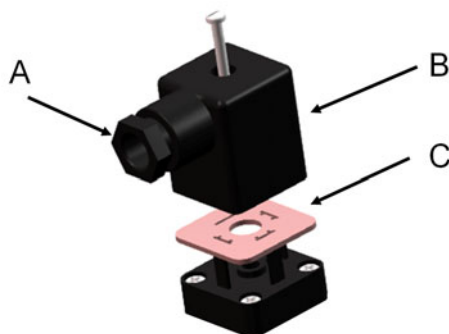

11 TMUR RESISTIVE SENSOR

11.1 Introduction

The TMUR resistive sensor is based on the variation of resistance as a function of the height of the float. This signal, once processed by a microcontroller, is converted into a two-wire current signal of 4-20 mA proportional to the flow rate.

11.2 Operation

For each flow, the float height activates a certain reed sensor incorporated in a set of resistances, giving a resistive value that becomes a current proportional to the flow rate.

11.3 Models

Depending on the need of each application, the following transmitters can be supplied:

- TR3420. 4-20 mA transmitter
- TR2420H. 4-20 mA transmitter + HART. Ex zone 2
- TR2420P. 4-20 mA transmitter + Profibus PA / Foundation Fieldbus. Ex zone 2
- TR2420Ex. 4-20 mA transmitter. Ex ia IIC T6
- TR2420HEx. 4-20 mA transmitter + HART. Ex ia IIC T6
- TR2420FPEX. 4-20 mA transmitter + Profibus PA / Foundation Fieldbus. Ex ia IIC T6

Information related to these transmitters can be found in the transmitter specific instructions manual.

11.4 Electrical connection

For the electrical installation it is recommended to use multiple conductor cables, and not single cables, in order to guarantee the cable gland will stay watertight. The connector has a PG9 cable gland for cables with outer diameters between 4.5 mm and 7 mm. The numbering of the terminals is the following:

Terminal 1:	Resistive sensor
Terminal 2:	Resistive sensor
Terminal 3:	Not connected
Earth terminal:	Not connected

12 MAINTENANCE

12.1 Series 6000

To perform the maintenance, it is necessary to disassemble some parts of the flowmeter.
Check the drawings below for reference.

12.1.1 Non-guided float model

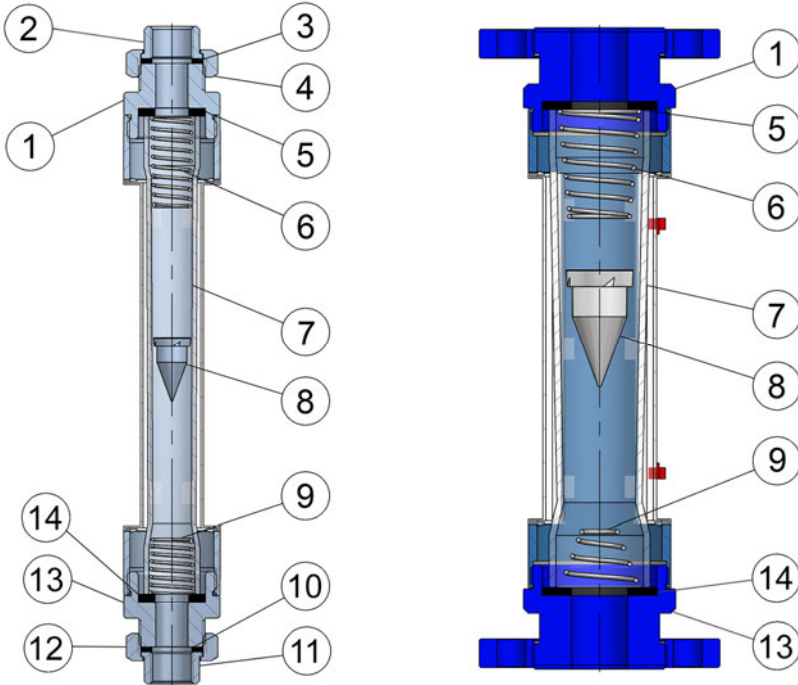

If the connection is threaded, unscrew the union nut (4) and remove the end connector (2) and the gasket (3).

Unscrew the end piece (1) and remove the gasket (5).

Remove the upper spring or stop (6).

Carefully slide the float (8) until it is removed from the measuring tube (7).

Remove the glass tube (7) and then the lower spring or stop (9).

If the connection is threaded, unscrew the lower union nut (12) and remove the end connector (11) and the gasket (10).

Unscrew the lower end piece (13) and remove the gasket (14).



To remove adhered chemical dirt to the float (8) or metering tube (7), clean the parts with suitable products or solvents and soft brushes, never use metallic tools.

To reassemble the instrument, check if the gaskets (3), (5), (10) and (14) are in good condition. If not, replace them.

Fit the gasket (14) and screw the lower end piece (13).

If the connection is threaded, fit the gasket (14) and screw the union nut (12).

Place the lower spring or stop (9).



NOTE: The upper spring or stop (6) is different from the lower one (9) and should not be exchanged.

Place the measuring tube in its position (7).

Carefully introduce the float (8), and then place the upper spring or stop (6).

Fit the gasket (5) in the upper end piece (1) and screw it.

If the connection is threaded, fit the gasket (3) and the end connector (2), and screw the union nut (4).

12.1.2 Guided float model

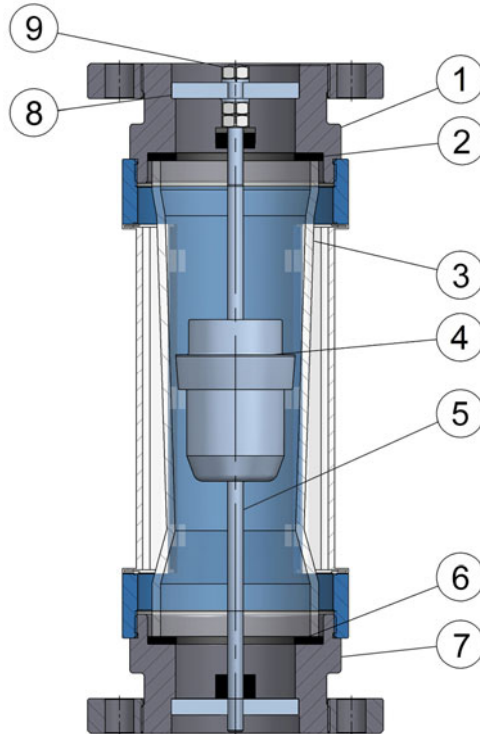

Loosen the nut (9) and remove the centering ring (8), taking care that the guide (5) does not tilt and preventing the float (4) from hitting the measuring tube (3).

Unscrew the upper end piece (1) and remove the gasket (2).

Carefully slide the float (4) together with the guide (5) until they are removed from the measuring tube (3).

Remove the measuring tube (3).

Unscrew the lower end piece (7) and remove the gasket (6).



To remove adhered chemical dirt to the float (4) or metering tube (3), clean the parts with suitable products or solvents and soft brushes, never use metallic tools.

To reassemble the instrument, check if the gaskets (2) and (6) are in good condition. If not, replace them.

Fit the gasket (6) and screw the lower end piece (7).

Place the measuring tube (3) in its position.

Carefully introduce the guide (5) with the float (4) into the measuring tube (3).

Fit the gasket (2) on the upper end piece (1) and screw it.

Place the centering ring (8) and check that the float (4) is centered and its movement is smooth. If the float (4) was not centered, it could break the measuring tube (3) when rubbing against it.

Finally, tighten the nut (9).

12.2 Potential problems with the measuring tube

12.2.1 Jammed float

To remove the float, follow the steps in section 12.1.

To remove adhered chemical dirt to the float, the measuring tube, clean the parts with suitable products or solvents and soft brushes, never use metallic tools.

The float may also become clogged by accumulation of metallic particles around it in case the float is magnetic (for operating with switches or resistive sensor). In this case install a magnetic filter at the inlet of the meter, or just a normal filter depending on the size and nature of the particles.

Follow the steps in section 12.1 to reassemble the flowmeter.

12.2.2 Damaged float

Check that it does not show any impacts or scratches. Also check for any chemical attack. If the float is in bad condition it must be replaced. In this case it is recommendable to recalibrate the flowmeter at Tecfluid S.A. facilities.

12.3 AMD limit switch maintenance

12.3.1 Electrical verification

Check that the voltage at the terminals + and - is over 7.5 V when the vane is in the slot. Connect a multimeter with the scale in DC mA, in series with the terminal +.

Verify that the current is less than 1 mA when the vane is inside the slot and more than 3 mA when the vane is outside the slot.

If a NAMUR amplifier is not available, the verification can be done with the following circuit diagram:

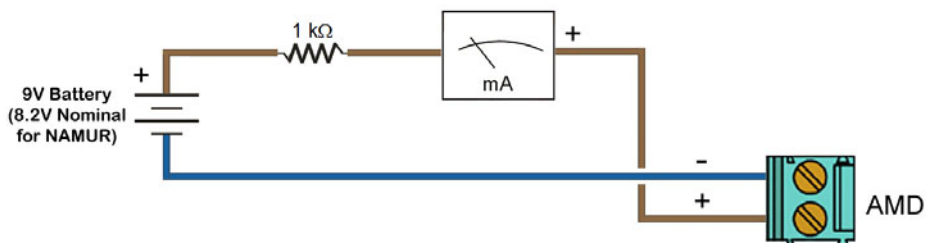

Without the sensor, the operation of the amplifier can be checked by using the following circuit diagram:

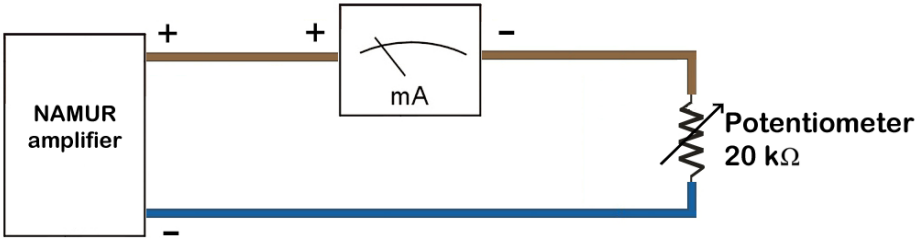

With the potentiometer the current through the NAMUR amplifier can be modified. The switching point must be between 1.2 mA and 2.1 mA. That is, with the current below 1.2 mA the output relay must have a state and above 2.1 mA the output relay must have the other state.

12.4 AMM limit switch maintenance

The micro-switch (1) has a roller that runs on the cam (2).

To check the operation and correct possible misalignments, do the following steps:

Open the limit switch housing by removing the four M4 x 25 DIN 7985 screws.

Check that the magnet assembly (5) is firmly fixed to the shaft by the screw (4).

Position the screw (4) as in the drawing (against the stop in a clockwise direction). Position the cam (2) as in the drawing and tighten the screw (3).

If a multimeter with resistance measurement is available, connect it to terminals 1 & 2 of the connector. Move the cam (2) slowly in both directions over the whole of its travel. The multimeter must change from open circuit to short circuit in one direction and vice versa in the other, when the roller is half way up the eccentric zone of the cam.



When a multimeter is not available, the above can be done by hearing the “click” when the micro-switch (1) changes over.

Note: If due to bad handling of the micro-switch lever, the operation is not correct, the micro-switch lever (1) should be bent slightly until correct operation is obtained.

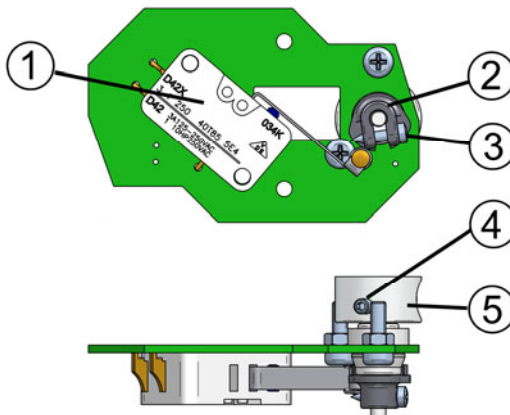

12.5 AMR limit switch maintenance

If the limit switch must be changed from a PT-AMR NC to a PT-AMR NA or vice versa, the procedure is the following:

Remove the female connector (B) by unscrewing the central screw and then the rubber seal (C).

Unscrew the 4 screws that hold the male connector (D).

Withdraw the connector, rotate it 180° and reassemble it carefully.

Fit the gasket (C) and then the female connector (B). Screw the central screw.

Take care that the seals are properly fitted to maintain the ingress protection.

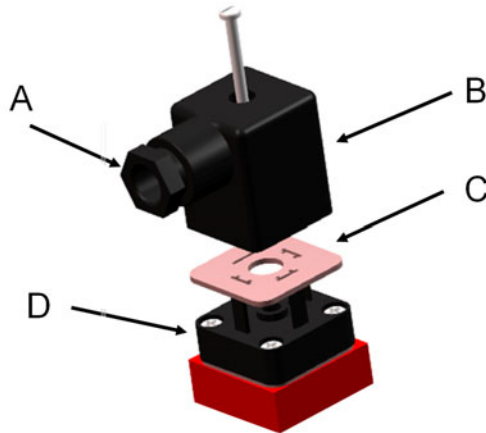

13 TECHNICAL CHARACTERISTICS

13.1 Series 6000

Accuracy: 1.6% ($q_G=50\%$) according to VDI/VDE 3513 sheet 2.

Scales: In l/h, m³/h, kg/h, l/min, %, etc.

Mounting: Vertical (Upwards flow)

Scale range: 10:1

Working temperature: -20°C ... +80°C

The glass tube can withstand a thermal shock of 150°C if there is no internal pressure.

The temperature difference between the interior and exterior of the glass tube must not exceed 80°C.

Ambient temperature: -20°C ... +60°C

Working pressure: Glass tubes between 25 and 1000 l/h: 15 bar max.
Glass tubes between 1600 and 2500 l/h: 10 bar max.
Glass tubes between 4000 and 6300 l/h: 8 bar max.
Glass tubes between 10 and 14 m³/h: 6 bar max.
Glass tubes between 16 and 50 m³/h: 5 bar max.

Connections: Threaded: ½" ... 3" BSP / NPT, PVC solvent socket or SS connections for welding
 EN 1092-1 or ASME B16.5 flanges: DN15 ... DN80 or ½" ... 3". Other flange standards on request
 Sanitary couplings according to ISO 2852, SMS 1145, DIN 11851, TRI-CLAMP®

13.2 AMD limit switch

Nominal voltage	8 V
Working voltage	5 ... 25 V
Power supply internal resistance	1 kΩ
Current with the vane inside the slot	< 1 mA
Current with the vane outside the slot	≥ 3 mA
Standard:	DIN EN 60947-5-6 (NAMUR)
Ambient temperature	-25°C ... +100°C

13.3 AMM limit switch

DIN 43650 A connector

Technical characteristics of the micro-switch:

Maximum switching voltage:	250 VAC
Maximum switching current:	3 A
Hysteresis:	±10% of full scale value
Ingress protection:	IP65
Ambient temperature:	-25°C ... +80°C

13.4 AMR limit switch

DIN 43650 A connector

Technical characteristics of the reed sensor:

Maximum switching power:	12 VA
Maximum switching voltage:	250 VAC
Maximum switching current:	0.5 A
Hysteresis:	±5% of full scale value
Ingress protection:	IP65
Ambient temperature:	-25°C ... +80°C

14 SAFETY INSTRUCTIONS

The series 6000 flowmeters are in conformity with all essential requirements of all EC directives applicable to them:

2014/68/EU Pressure equipment directive (PED)

Limit switches and transmitters:

2014/30/EU Electromagnetic compatibility directive (EMC)

2012/19/EU Waste electric and electronic equipment (WEEE).

2011/65/EU Restriction of the use of certain hazardous substances in electrical and electronic equipment (ROHS).

Equipment for hazardous areas:

2014/34/EU Equipment and protective systems intended for use in potentially explosive atmospheres (ATEX).

The declarations UE of conformity can be downloaded from the section “Download” of the Tecfluid S.A. website.



14.1 Pressure equipment directive

Tecfluid S.A. have subjected the series 6000 of flowmeters to a conformity assessment method for the pressure equipment directive, specifically according to module H (full quality assurance).

Conformity with the directive is reflected by the CE marking in each pressure equipment and by the written declaration of conformity. The CE marking is accompanied by the identification number of the notified body involved at the production control phase.

The marking of the equipment takes into account the fluid type, the group of fluid and the category, for example: G1 CATI

G Gases and vapours

1 Group of liquids 1

CATI Category I

Devices that, due to their size, are not subject to conformity assessment, are considered outside the scope of the directive and therefore they have not the CE mark according to pressure directive. These devices are subject to applicable sound engineering practice (SEP).



This equipment is considered as being a pressure accessory and **NOT** a safety accessory as defined in the 2014/68/EU directive, Article 2, paragraph 4.

14.2 Certificate of conformity TR CU (EAC marking)

Tecfluid S.A. have subjected the series 6000 of flowmeters to a certification procedure according to the technical regulations of the Customs Union of the Eurasian Economic Union (EEU).

This Certificate is an official document confirming the quality of production with the standards on the territory of the Customs Union, particularly regarding safety requirements and electromagnetic compatibility.



15 ADDITIONAL INSTRUCTIONS FOR THE ATEX VERSION

Instruments with AMM or AMR limit switches can be considered as a simple apparatus according to the IEC 60079-11 standard and therefore they are not marked as ATEX.

Instruments with AMD limit switch can be installed in potentially explosive atmospheres. These equipment conform with the directive 2014/34/EU (Equipment and protective systems intended for use in potentially explosive atmospheres) as indicated in the EC-type examination certificate and in its marking.

Given that this instrument is group II, it is intended for use in places likely to become endangered by explosive atmospheres, but not in mines.

The category is 2G, that is, it is intended for use in areas in which explosive atmospheres caused by mixtures of air and gases, vapours, mists are likely to occur in normal operation.

15.1 Non-metallic parts



WARNING: POTENTIAL RISK OF ELECTROSTATIC CHARGE



Since the danger of ignition by electrostatic discharge when rubbing the front and rear plastic protections can not be avoided, **the instrument must always be cleaned with a damp cloth.**

The AMD limit switch is certified as intrinsic safety with the following parameters:

Specific parameters	U _i : 16 V
	I _i : 25 mA
	P _i : 64 mW
	C _i : 30 nF
	L _i : 100 µH

16 FLOW RANGES

Model N°	Flow scales EN 1.4404 float 7.95 g/cm³			Flow scales Aluminium float 2.85 g/cm³			Max. Pressure bar	Frame	R" (DN)
	l/h water	Nm³/h air 1.013 bar abs 20°C		ΔP (mbar)	Nm³/h air 1.013 bar abs 20°C				
C31-00251	2.5-25	0.07-0.7		0.04-0.4					
C31-00401	4-40	0.11-1.1		0.07-0.7		2			
C31-00601	6-60	0.18-1.8		0.1-1					
C32-01001	10-100	0.3-3		0.17-1.7			M1	½" (DN15) ¾" (DN20)	
C32-00601	16-160	0.45-4.5		0.25-2.5		4		15	
C32-02501	25-250	0.7-7		0.4-4					
C33-04001	40-400	1.1-11		0.7-7					
C33-06301	60-630	1.8-18		1.1-11		5			
C33-10001	100-1000	3-30		1.8-18			M2	¾" (DN20) 1" (DN25)	
C34-16001	160-1600	4.5-45		2.5-25					
C34-25001	250-2500	7-70		5-45		8	10	M3.1	
C35-40001	400-4000	11-110		7-70				1 ½" (DN40)	
C35-63001	500-6300	18-180		10-110		10	8	M3.2	
C36-M0101	1000-10000	30-300		20-180					
C36-M0141	2000-14000	120-420		40-250		12	6	M4	2" (DN50)
C37-M0161	1600-16000	45-450		30-290					
C37-M0201	2000-14000	60-600		40-360					
C37-M0251	2500-25000	70-700		50-460					
C37-M0301	3000-30000	90-900		60-550		17	5	M5	2 ½" (DN65) 3" (DN80)
C37-M0401	6000-40000	180-1200		110-730					
C37-M0501	8000-50000	250-1500		170-920					

Model N°	AC float EN 1.4404 float 7,95 g/cm³			ECG float				Max. Pressure bar	R" (DN)	
	l/h water	Nm/h air 1,013 bar abs 20°C		Glass float 2,60 g/cm³		Plastic float 1,30 g/cm³				
				ΔP (mbar)	l/h water	Nl/h air 1,013 bar abs 20°C	Nl/h air 1,013 bar abs 20°C			ΔP (mbar)
C30-00251	2,5-25	70-700		3	1-10	40-400	15-150	2	15	½"
C30-00401	4-40	120-1200			1,6-16	70-700	25-250			(DN15)

17 DIMENSIONS

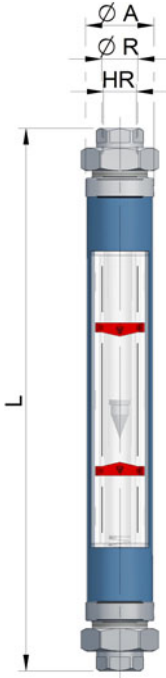

Model 6001 (BSP / NPT), PVC solvent socket or EN 1.4404 connections for welding

Frame	R" NPT	DN	A	HR	L	Weight kg
M1	½"	15	50	17	405	22
M1	¾"	20	50	19	410	2
M2	¾"	20	60	19	418	22
M2	1"	25	60	20	423	3
M3	1 ½"	40	90	20	445	66
M4	2"	50	103	22	455	10
M5	2 ½"	65	140	24	502	133
M5	3"	80	140	26	512	17

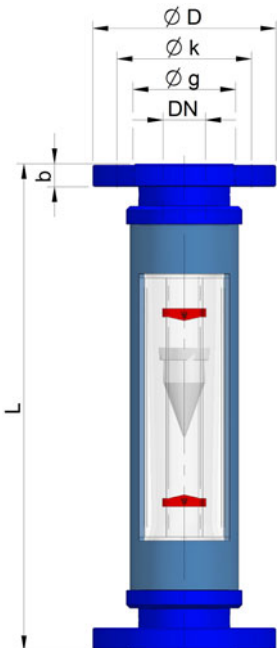

Model 6002 (EN 1092-1) PN16

Frame	DN	D	k	g	b	l x n°	L	Weight kg
M1	15	95	65	45	16	14x4	380	2,5
M1	20	105	75	58	18	14x4	380	3,3
M2	20	105	75	58	18	14x4	390	3,3
M2	25	115	85	68	18	14x4	390	4,8
M3	40	150	110	88	18	18x4	400	8
M4	50	165	125	102	18	18x4	410	11
M5	65	185	145	122	18	18x4	420	15,3
M5	80	200	160	138	20	18x4	420	19,3

All dimensions in mm (L±1,5 mm)

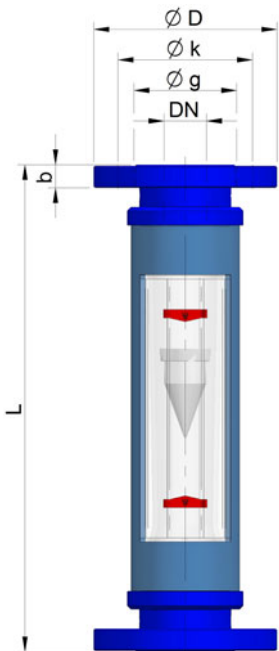

Model 6002 (ASME B16.5 150#)

Frame	NPS	D	k	g	B	l x n°	L	Weight kg
M1	½"	88,9	60,3	34,9	11,1	15,9x4	380	2,5
M1	¾"	98,4	69,8	42,9	12,7	15,9x4	390	3,3
M2	¾"	98,4	69,8	42,9	12,7	15,9x4	390	3,3
M2	1"	107,9	79,4	50,8	14,3	15,9x4	390	4,8
M3	1" ½"	127	98,4	73	17,5	15,9x4	400	8
M4	2"	152,4	120,6	92,1	19,1	19x4	410	11
M5	2 ½"	177,8	139,7	104,8	22,2	19x4	420	15,3
M5	3"	190,5	152,4	127	23,8	19x4	420	19,3

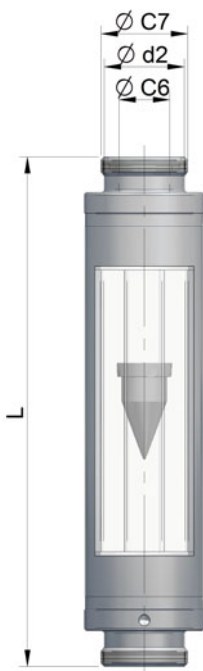

Model 6011 (DIN 11851)

NW	15(M1)	25(M2)	40(M3)	50(M4)	65(M5)	80(M6)	100(M5)
Ø C7	Rd 34 x 1/8"	Rd 52 x 1,6"	Rd 65 x 1/6"	Rd 78 x 1/6"	Rd 95 x 1/6"	Rd 110 x 1/4"	Rd 130 x 1/4"
Ø C6	16	26	38	50	66	81	100
Ø d2	21,3	30	42	51	73	88,9	108
L*	395	400	405	425	425	425	425

All dimensions in mm (L±1,5 mm)



Model 6013 (CLAMP ISO 2852:1993)

NW	15(M1)	25(M2)	40(M3)	50(M4)	65(M5)	80(M6)	100(M5)
Ø C7	34	50,5	50,5	64	77,5	91	119
Ø C6	14	22,6	35,6	50	60,3	72,9	97,6
Ø d2	25,3	42,4	42,4	55,8	68	81	106
L	395	400	405	425	425	425	425

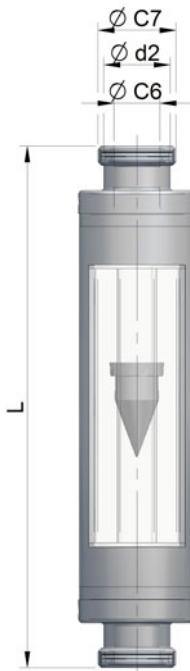

Model 6015 (SMS 1145)

NW	15(M1)	25(M2)	40(M3)	50(M4)	65(M5)	80(M6)	100(M5)
Ø C7	Rd 40-6	Rd 48-6	Rd 60-6	Rd 70-6	Rd 85-6	Rd 120-4	Rd 140-4
Ø C6	22,5	29,4	35,5	48,5	60,5	86	104
Ø d2	25	42	51	63,5	73	86	108
L	395	400	405	425	425	425	425

All dimensions in mm (L±1,5 mm)

AMR limit switch

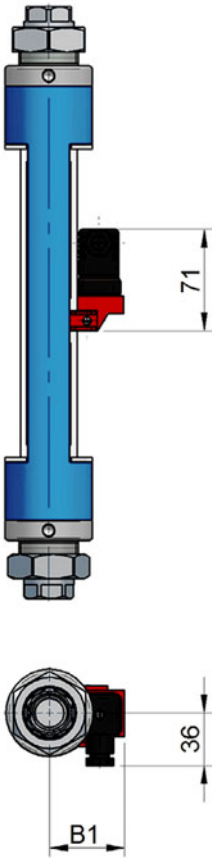

AMD or AMM limit switch

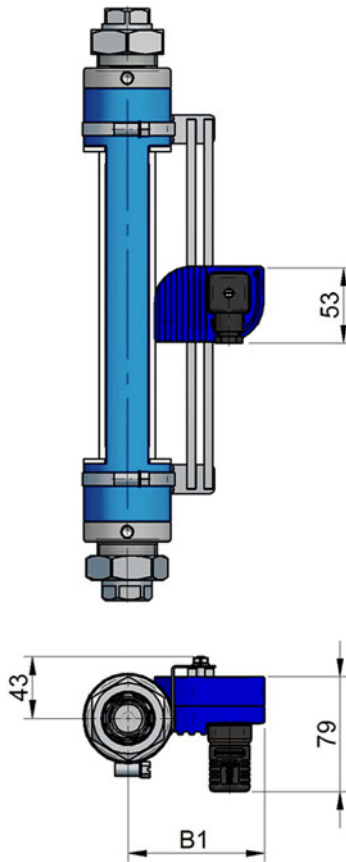

TMUR resistive sensor

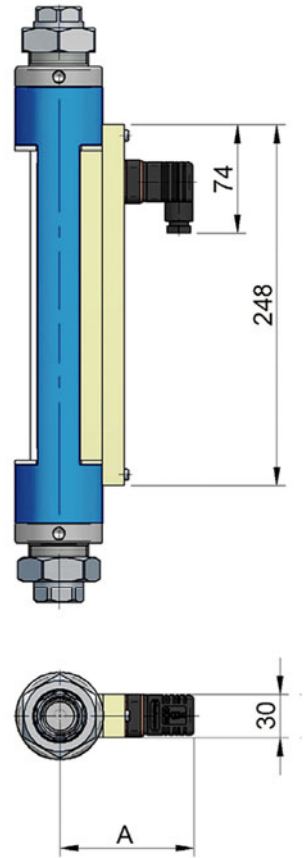

Frame	DN	B1
1	15 ... 20	48
2	20 ... 25	51,5
3.1	40	61
3.2	40	67,5
4	50	80
5	65 ... 80	94

Frame	DN	B1
1	15 ... 20	90
2	20 ... 25	96
3.1	40	111
3.2	40	111
4	50	117
5	65 ... 80	130

Frame	DN	A
1	15 ... 20	80
2	20 ... 25	85
3.1	40	101
3.2	40	101
4	50	107
5	65 ... 80	120

(All dimensions in mm)

18 EQUIVALENCE CURVES

Flow rate water-liquids with different density and viscosity

Flow rate

Flow rate

Change in viscosity (graph 1)

Change in density (graph 2)

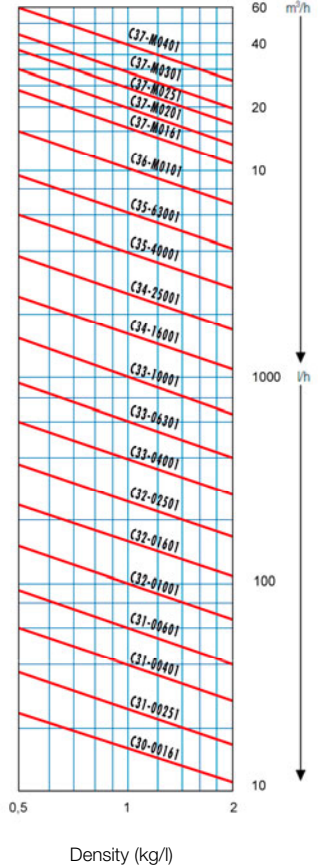
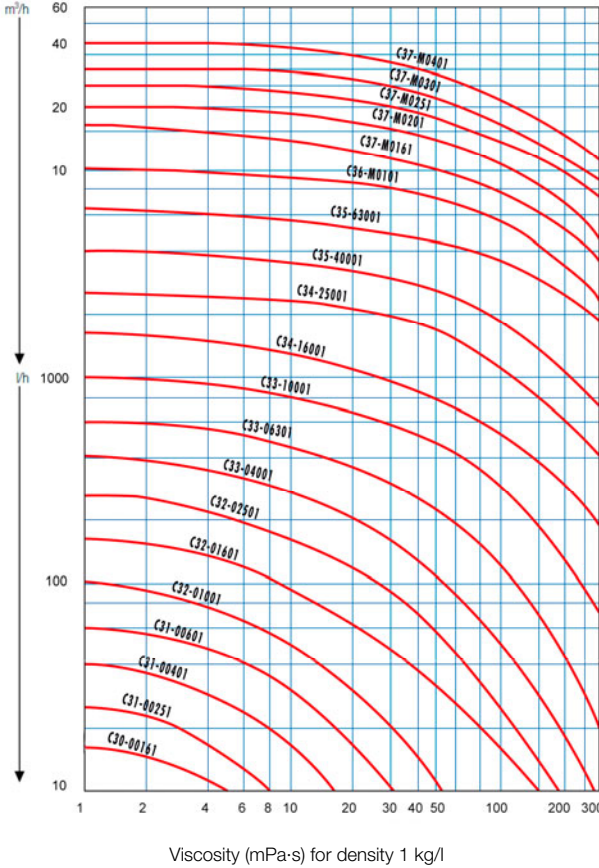

Example 1. Changes in density (graph 2)

Flow rate to be measured: 1000 l/h Liquid density: 1.4 kg/l

Enter the graph at the 1000 l/h point and move horizontally to the left until the thick line that determines the proper flow tube (C33-10001). Follow the inclined line until crossing the 1.4 kg/l vertical line. From this point, move horizontally to the right until reaching the flow scale axis, where we can determine that the maximum flow rate we can measure with this tube is 800 l/h.

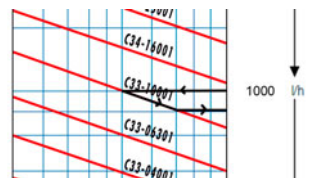

Example 2. Changes in viscosity (graph 1)

Flow rate to be measured: 1000 l/h Liquid viscosity: 50 mPa·s

Enter the graph 1 by the 50 mPa·s value on the lower scale, and move vertically until crossing with the horizontal 1000 l/h flow rate line.

Since this point is between two curves, we can:

- Choose the lower curve:

Move downwards along the 50 mPa·s line until the lower curve (tube C34-16001) and then move horizontally to the left until reaching the flow scale axis. We can determine that the maximum flow rate we can measure with this tube is 800 l/h.

- Choose the upper curve:

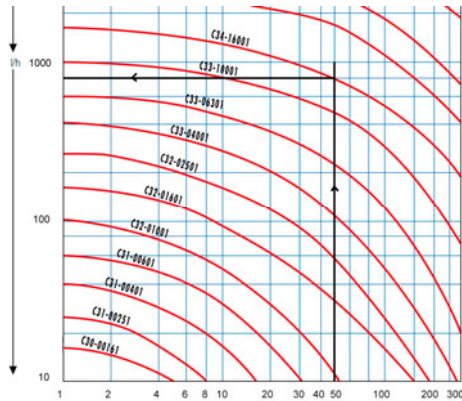

Move upwards along the 50 mPa·s line until the upper curve (tube C34-25001) and then move horizontally to the left until reaching the flow scale axis. We can determine that the maximum flow rate we can measure with this tube is 1800 l/h. In case that the viscosity and the flow tube lines meet, that would directly be the maximum flow rate value we can measure.

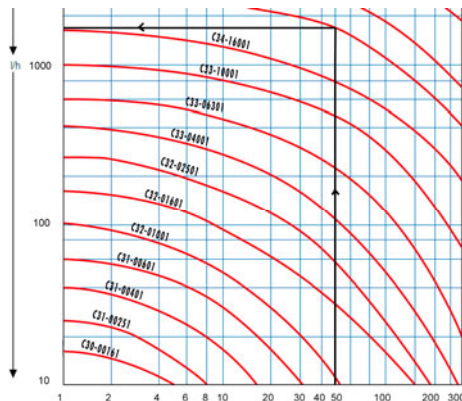

Nº 3. Changes in viscosity and density (graphs 1 and 2)

Follow example nº 2 first and then nº 1.

WARRANTY

Tecfluid S.A. guarantee all the products for a period of 24 months from their sale, against all faulty materials, manufacturing or performance. This warranty does not cover failures which might be imputed to misuse, use in an application different to that specified in the order, the result of service or modification carried out by personnel not authorized by Tecfluid S.A., wrong handling or accident.

This warranty is limited to cover the replacement or repair of the defective parts which have not damaged due to misuse, being excluded all responsibility due to any other damage or the effects of wear caused by the normal use of the devices.

Any consignment of devices for repair must observe a procedure which can be consulted in the website www.tecfluid.com, "After-Sales" section.

All materials sent to our factory must be correctly packaged, clean and completely exempt of any liquid, grease or toxic substances.

The devices sent for repair must enclose the corresponding form, which can be filled in via website from the same "After-Sales" section.

Warranty for repaired or replaced components applies 6 months from repair or replacement date. Anyway, the warranty period will last at least until the initial supply warranty period is over.

TRANSPORTATION

All consignments from the Buyer to the Seller's installations for their credit, repair or replacement must always be done at freight cost paid unless previous agreement.

The Seller will not accept any responsibility for possible damages caused on the devices during transportation.



Tecfluid S.A.

Narcís Monturiol 33
08960 Sant Just Desvern
Barcelona

Tel: +34 93 372 45 11

Fax: +34 93 473 44 49

tecfluid@tecfluid.com

www.tecfluid.com

Quality Management System ISO 9001 certified by



Pressure Equipment Directive 2014/68/UE certified by



ATEX European Directive 2014/34/EU certified by



HART is a registered trademark of Fieldcomm Group™

The technical data described in this manual is subject to modification without notification if the technical innovations in the manufacturing processes so require.