



---

# K Series Gear Units

Edition OIKCE 0203 / 1014

# Operating Instructions

---



<b>Contents.....</b>	<b>02</b>
<b>1 -How To Use This Manual .....</b>	<b>04</b>
<b>2 -Unit Designation.....</b>	<b>05</b>
2.1- Detailed unit designation .....	05
2.2- Nameplate, unit designation.....	06
<b>3.Standard type Gearbox Part List.....</b>	<b>07</b>
3.1- Size: K00...K20 Type: 00.....	07
3.2- Size: K00...K20 Type: 01L.....	08
3.3- Size: K00...K20 Type: 01R .....	09
3.4- Size: K00...K20 Type: 02L.....	10
3.5- Size: K00...K20 Type: 02R .....	11
3.6- Size: K00...K20 Type: 03L.....	12
3.7- Size: K00...K20 Type: 03R .....	13
3.8- Size: K00...K20 Type: 04 .....	14
3.9- Size: K00...K20 Type: 05.....	15
3.10- Size: K00...K20 Type: 08.....	16
3.11- Size: K27...K87 Type: 00 .....	17
3.12- Size: K27...K87 Type: 01.....	18
3.13- Size: K27...K87 Type: 02.....	19
3.14- Size: K27...K87 Type: 03.....	20
3.15- Size: K27...K87 Type: 04.....	21
3.16- Size: K27...K87 Type: 05.....	22
3.17- Size: K27...K87 Type: 08.....	23
3.18- Size: K27...K87 Type: 0S .....	24
3.19- Size: K27...K87 Type: 0E .....	25
<b>4- Safety .....</b>	<b>26</b>
4.1- Intended Use .....	26
4.2- Improper Use.....	26
4.3- Safety Instructions.....	27
4.3.1- General Safety Instructions .....	27
4.3.1.1- Working on the gear reducer .....	27
4.3.1.2- Operation .....	27
4.4- Tightening Torques.....	28
4.5- Case of Fire.....	28
<b>5 -Things to Check Before the Gear Unit or Geared Motor is Installed.....</b>	<b>29</b>
5.1- Transportation .....	29
5.2- Storage.....	30
<b>6- Installing The Gear Unit.....</b>	<b>30</b>
6.1- Before you start.....	30
6.2- Check the shaft dimensions to fit .....	31
6.3- Check the ambient temperature .....	31



6.4- Check the voltage supply.....	31
6.5- Check the mounting position.....	34
6.6- Use of breather plug.....	34
6.7- Check the oil level.....	34
6.8- Check shaft ends and mounting faces.....	34
6.9- Cover abrasive ambient.....	34
6.10- Check accessibility to filling, breather and drain plugs.....	35
<b>7- Mechanical Installation .....</b>	<b>35</b>
7.1- Installing customer shaft with shoulder .....	36
7.2- Installing customer shaft without shoulder .....	37
7.3- Disassembling customer shaft with shoulder .....	38
7.4- Disassembling customer shaft without shoulder .....	39
7.5- Shaft tightening torques .....	40
7.6- Recommended shaft dimensions for KT...00 types .....	41
7.7- Assembling customer shaft with shrink disk.....	42
7.8- Disassembling customer shaft with shrink disk.....	44
7.9- Assembling gear unit with torque arm.....	45
7.10- Fixing bold position.....	47
7.11- K.00.. - K.20.. Torque arm assembly details.....	48
7.12- Fitting output shaft elements.....	49
7.12- Correct position of output shaft elements.....	49
7.13- Fitting couplings .....	50
<b>8- Maintenance and Inspections .....</b>	<b>51</b>
<b>9- Lubrication .....</b>	<b>53</b>
9-1 Oil Types .....	53
9.2- Changing the oil .....	54
9.3- Oil Quantities. (lt) and oil plugs .....	54
9.4- Mounting Positions .....	58
<b>10- Troubleshooting Guide.....</b>	<b>59</b>
<b>11- Disposal.....</b>	<b>62</b>
11.1- Disposal of Oil .....	62
11.2- Disposal of Sealings.....	62
11.3- Disposal of Metal.....	62
<b>12- Appendix.....</b>	<b>63</b>
Warranty Conditions.....	64
Warranty Declarations.....	65
Service Contact Points.....	66



## 1 -How To Use This Manual

Take attention to the following safety and warning signs for proper understanding and quick reference.



Electric Hazard; Can cause severe or fatal injuries.



Mechanical Hazard; Can cause severe or fatal injuries.



Likely to be Hazardous; Can cause minor or fatal injuries



Damage Risk; Can damage the drive or environment



Important Information



### **EC Machinery Directive:**

Within terms of the EC machinery directive 2006/42/EC, the gear reducer is not considered an autonomous machine, but as a component to install in machines.

Operation is prohibited within the area of validity of the 2006/42/EC directive, until it has been determined that the machine, in which this product is installed, corresponds to the regulations within this directive.

The operating instructions contain important information to ensure;

- Trouble-free operation
- Fulfilment of any rights to claim under guarantee

The operating instruction must be kept close to the gearbox and must be available in case it is needed.

This operating instruction is written for K Series gear units and is applicable only for K Series. If any different type of gearbox is used please ask YILMAZ REDUKTOR for the operating instructions of that type.

This instruction can be used only for standard type geared units of YILMAZ REDUKTOR. For special application and modified gear units ask YILMAZ REDUKTOR for validity.

This manual does not cover 94/9/EC compatible gearboxes. For 94/9/EC contact YILMAZ REDUKTOR.

# Operating Instructions

## K Series

### Unit Designation



## 2 -Unit Designation

### 2.1- Detailed unit designation



Detailed K Series gear units designation for ordering

(This Designation is different from the short nameplate designation)

**K R 3 7 3 . 02 R - M2 T1 - 90S/4 - L05**

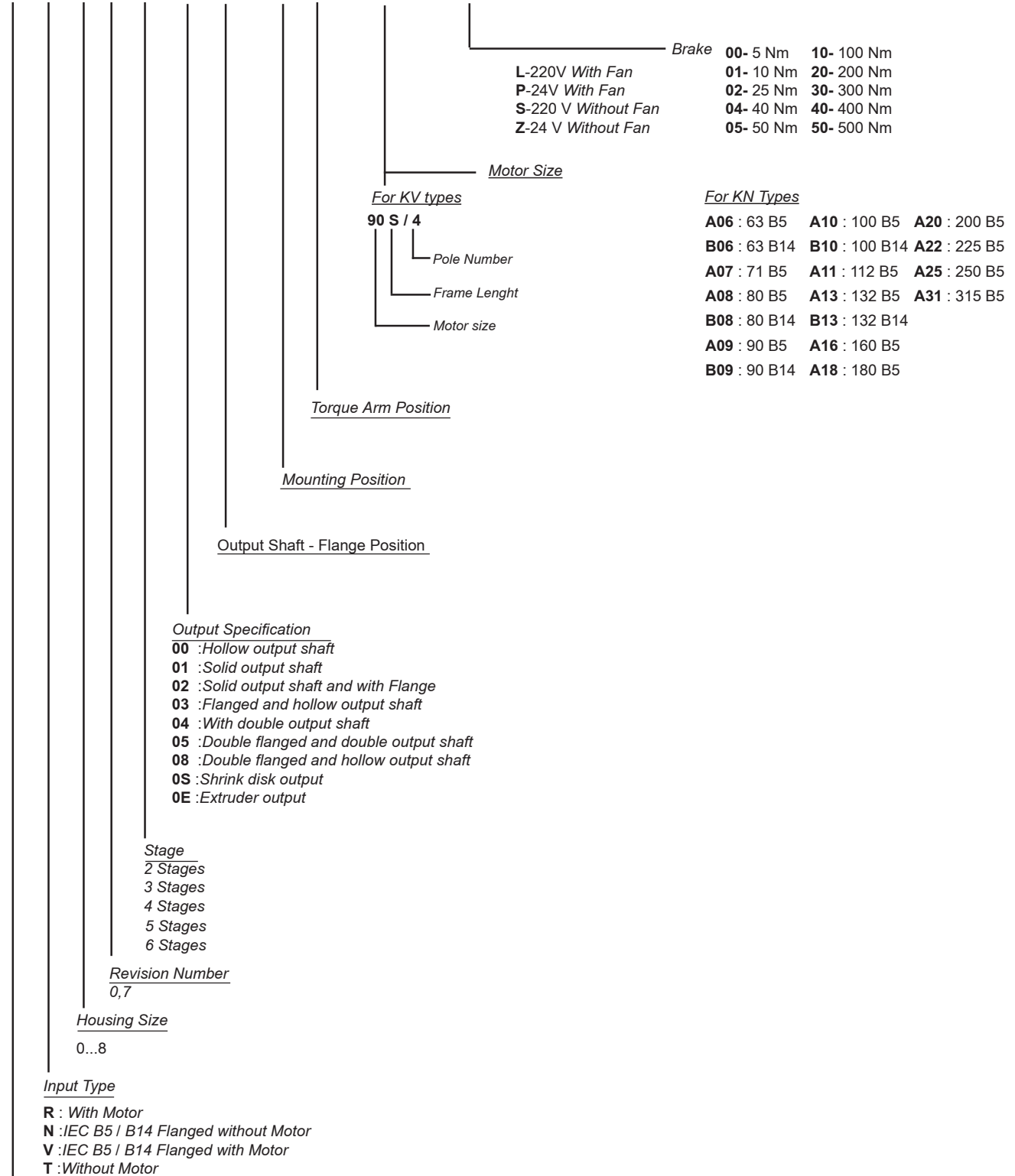

Gearbox Type

K Serie





## 2.2- Nameplate, unit designation



*Nameplate unit designation is a short abbreviation from the detailed designation*

A sample name plate for K Series

	<b>YILMAZ REDÜKTÖR</b> www.yr.com.tr MADE IN TURKEY	
Type: <b>KR373.00.100L / 4a</b>		
Serial N.: <b>10005289</b>		
Power : <b>3</b> kW	Ratio: <b>51.05</b>	
Speed : <b>27</b> rpm.	M. Pos.: <b>M1</b>	
Oil: <b>ISO VG 220</b> (Mineral Oil)	Oil Qty : <b>2.1</b> lt.	

### Abbreviations:

Serial N. : Serial Number

M.Pos. : Mounting Position

### Type Designation;

KR373.00  
Type

R

Shaft Arrangement

**Viewed from input side**

L - Right Input, Left Output

R - Left Input, Right Output

# Operating Instructions

## K Series

### Part Designations



### 3. Standard Type Gearbox Parts Lists

3.1- Size: K00...K20...

Type: 00

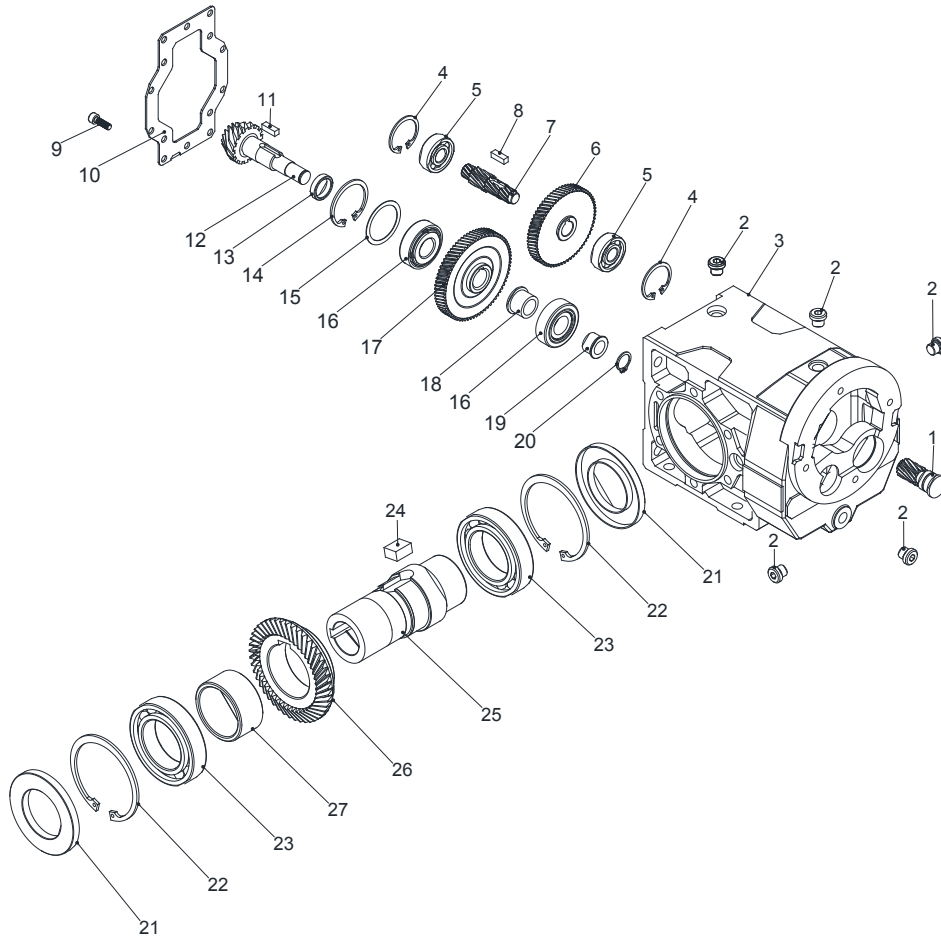

Standard types basic part diagram.  
Parts may differ for special applications.

#### Standard Part List

1- Pinion	9- Bolt	17- Gear	25- Output Shaft
2- Plug	10- Cover Plate	18- Spacer	26- Gear
3- Housing	11- Key	19- Spacer	27- Spacer
4- Circlip	12- Pinion Shaft	20- Circlip	
5- Bearing	13- Shim Ring	21- Oil Seal	
6- Gear	14- Circlip	22- Circlip	
7- Pinion Shaft	15- Shim Ring	23- Bearing	
8- Key	16- Bearing	24- Key	



3.2- Size: K00...K20...  
Type: 01L

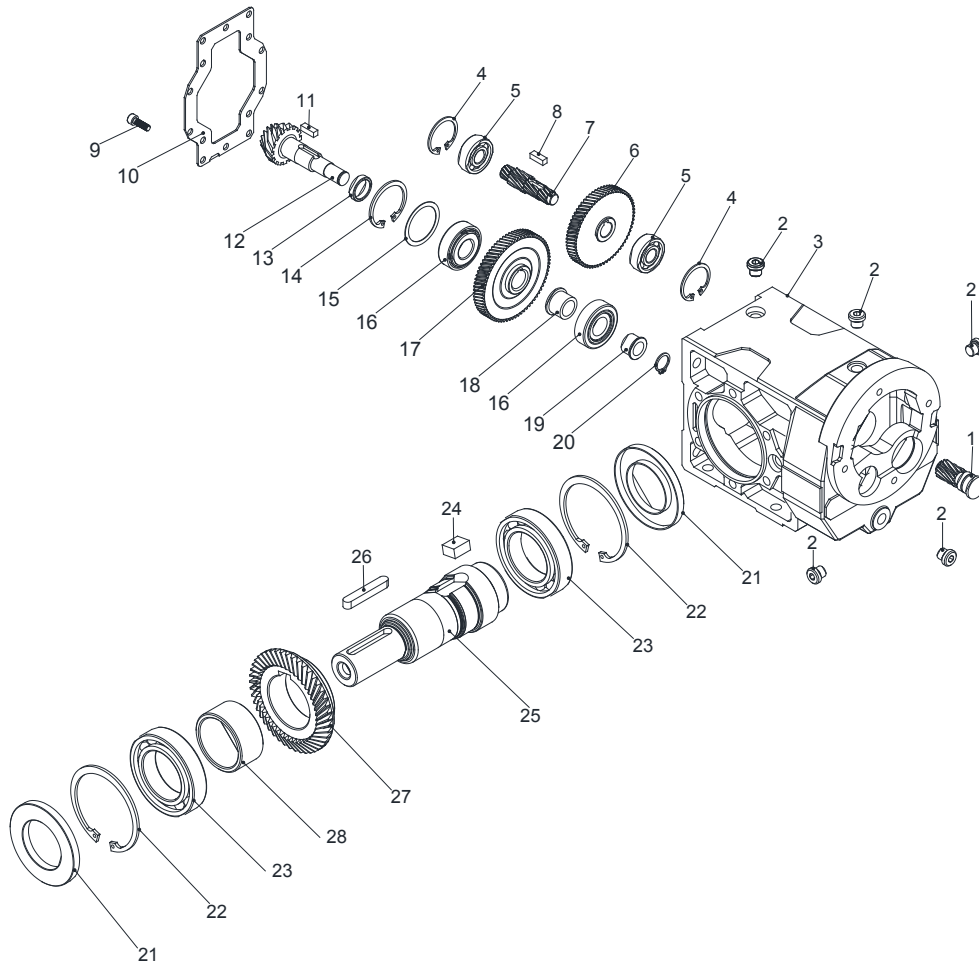

Standard types basic part diagram.  
Parts may differ for special applications.

Standard Part List

1- Pinion	9- Bolt	17- Gear	25- Output Shaft
2- Plug	10- Cover Plate	18- Spacer	26- Key
3- Housing	11- Key	19- Spacer	27- Gear
4- Circlip	12- Pinion Shaft	20- Circlip	28- Spacer
5- Bearing	13- Shim Ring	21- Oil Seal	
6- Gear	14- Circlip	22- Circlip	
7- Pinion Shaft	15- Shim Ring	23- Bearing	
8- Key	16- Bearing	24- Key	





3.3- Size: K00...K20...  
Type: 01R

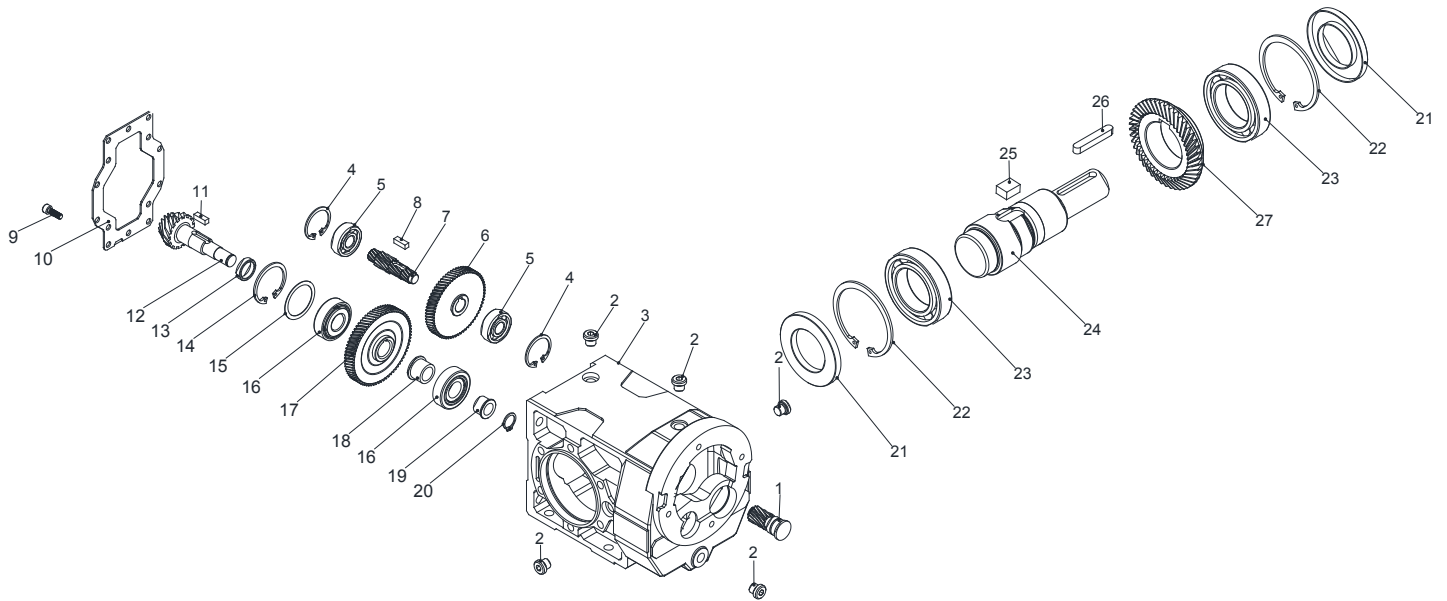

Standard types basic part diagram.  
Parts may differ for special applications.

Standard Part List

1- Pinion	9- Bolt	17- Gear	25- Key
2- Plug	10- Cover Plate	18- Spacer	26- Key
3- Housing	11- Key	19- Spacer	27- Gear
4- Circlip	12- Pinion Shaft	20- Circlip	
5- Bearing	13- Shim Ring	21- Oil Seal	
6- Gear	14- Circlip	22- Circlip	
7- Pinion Shaft	15- Shim Ring	23- Bearing	
8- Key	16- Bearing	24- Output Shaft	



3.4- Size: K00...K20...  
Type: 02L

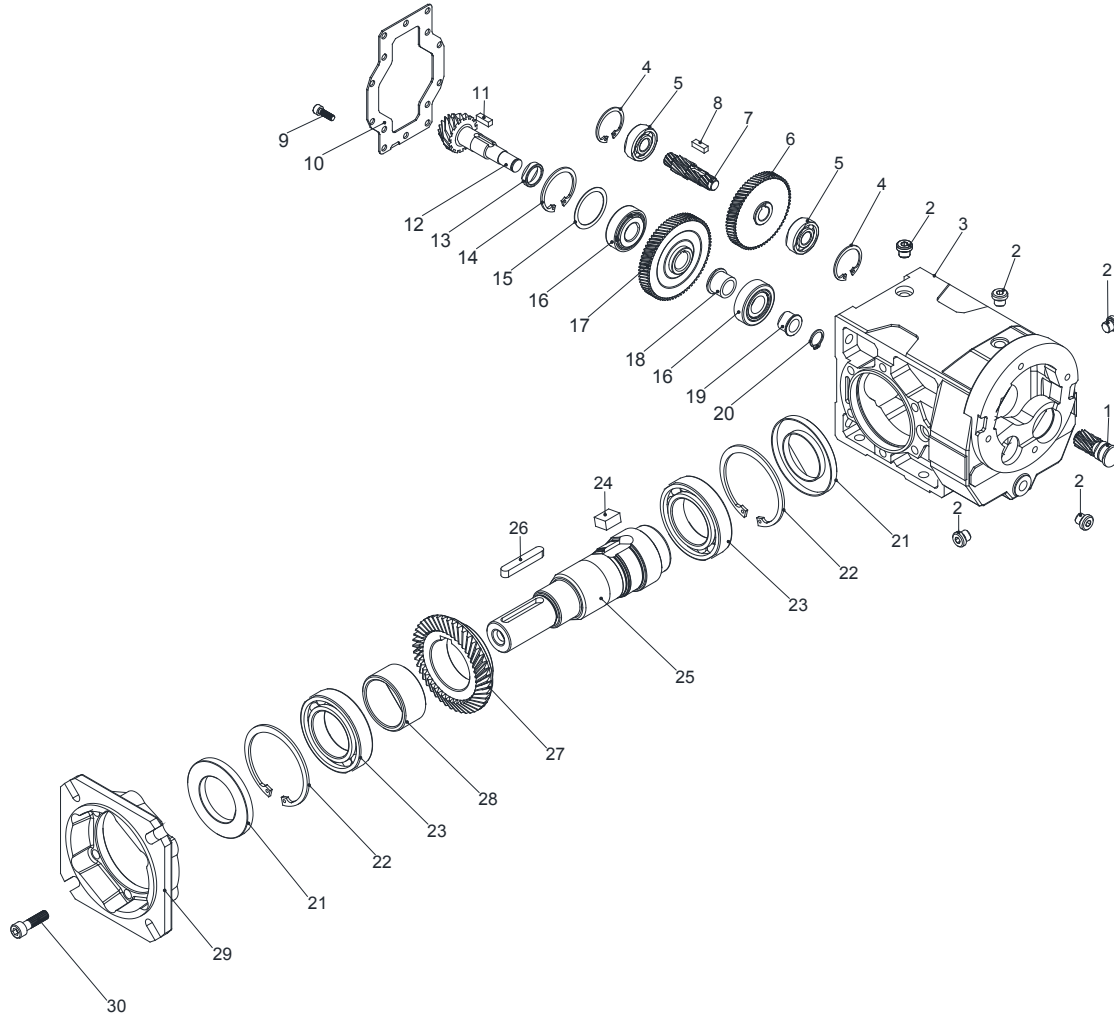

Standard types basic part diagram.  
Parts may differ for special applications.

Standard Part List

1- Pinion	9- Bolt	17- Gear	25- Output Shaft
2- Plug	10- Cover Plate	18- Spacer	26- Key
3- Housing	11- Key	19- Spacer	27- Gear
4- Circlip	12- Pinion Shaft	20- Circlip	28- Spacer
5- Bearing	13- Shim Ring	21- Oil Seal	29- Flange
6- Gear	14- Circlip	22- Circlip	30- Bolt
7- Pinion Shaft	15- Shim Ring	23- Bearing	
8- Key	16- Bearing	24- Key	

# Operating Instructions

## K Series

### Part Designations



3.5- Size: K00...K20...  
Type: 02R

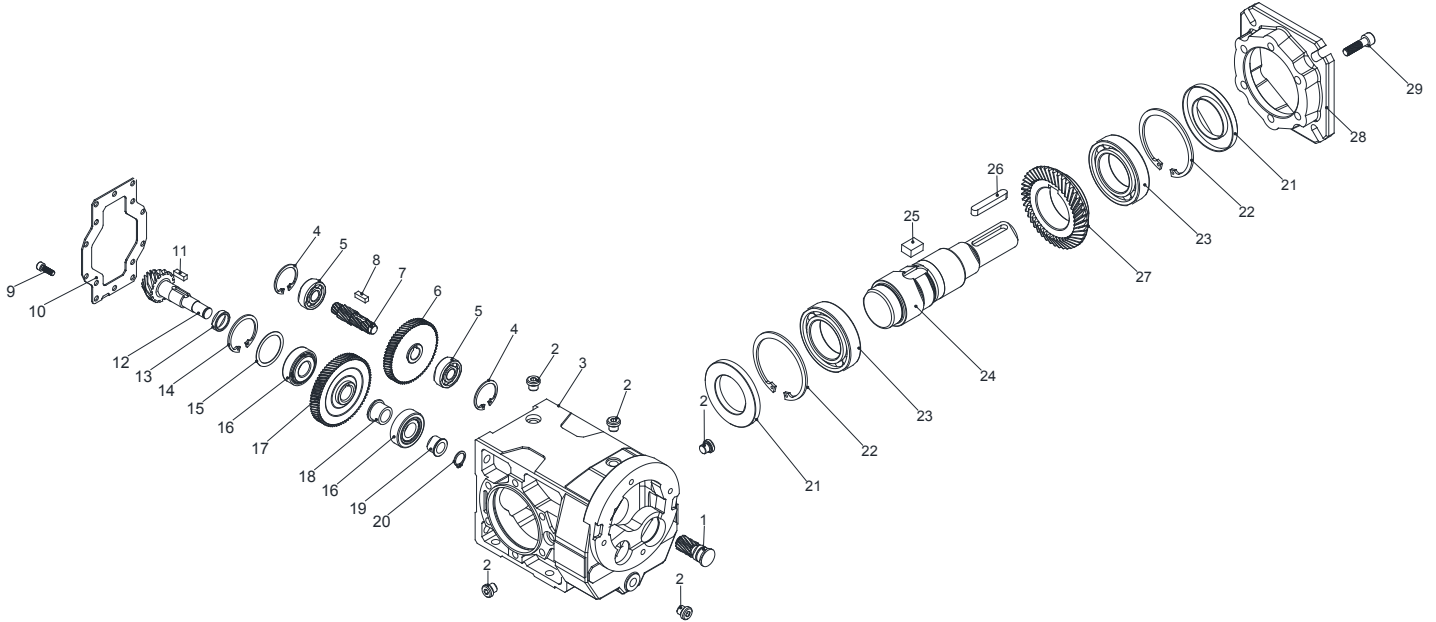

Standard types basic part diagram.  
Parts may differ for special applications.

#### Standard Part List

1- Pinion	9- Bolt	17- Gear	25- Key
2- Plug	10- Cover Plate	18- Spacer	26- Key
3- Housing	11- Key	19- Spacer	27- Gear
4- Circlip	12- Pinion Shaft	20- Circlip	28- Flange
5- Bearing	13- Shim Ring	21- Oil Seal	29- Bolt
6- Gear	14- Circlip	22- Circlip	
7- Pinion Shaft	15- Shim Ring	23- Bearing	
8- Key	16- Bearing	24- Output Shaft	



3.6- Size: K00...K20...  
Type: 03L

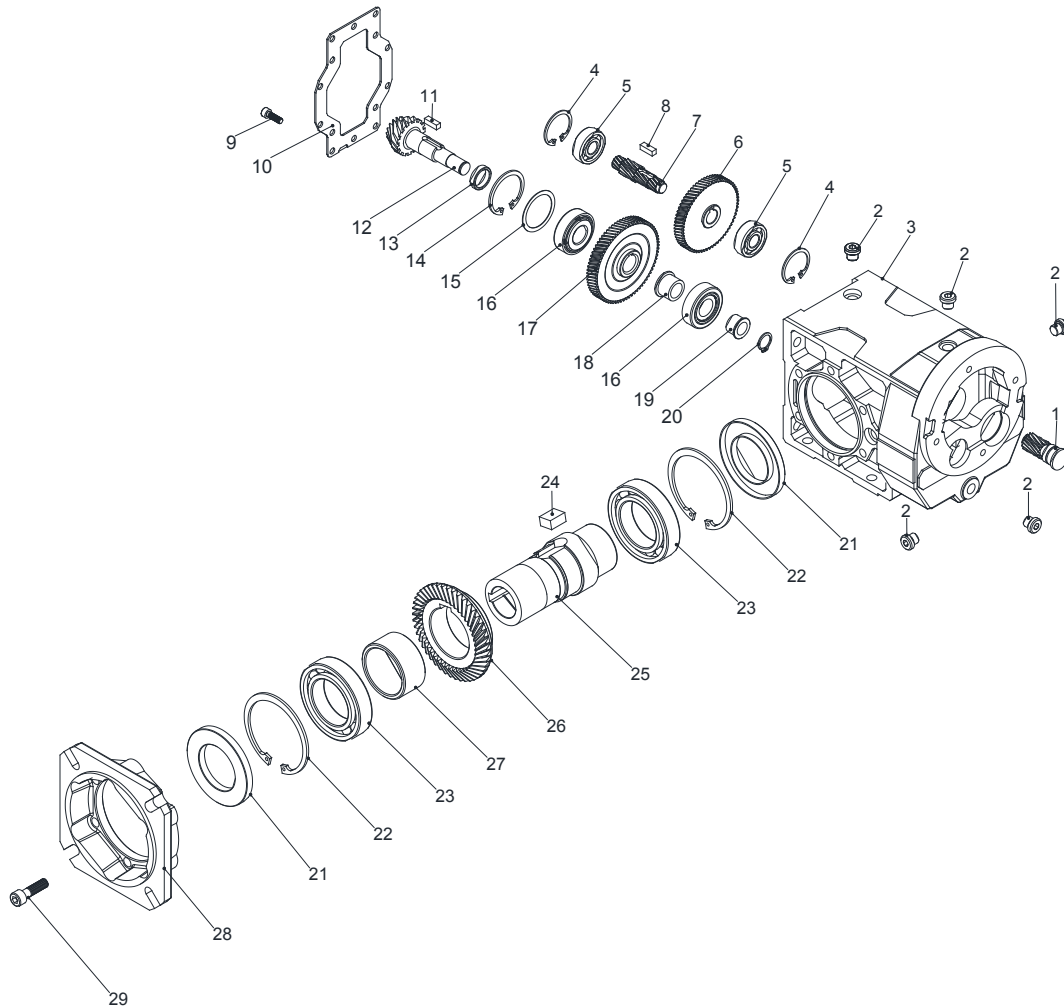

*Standard types basic part diagram.  
Parts may differ for special applications.*

Standard Part List

1- Pinion	9- Bolt	17- Gear	25- Output Shaft
2- Plug	10- Cover Plate	18- Spacer	26- Gear
3- Housing	11- Key	19- Spacer	27- Spacer
4- Circlip	12- Pinion Shaft	20- Circlip	28- Flange
5- Bearing	13- Shim Ring	21- Oil Seal	29- Bolt
6- Gear	14- Circlip	22- Circlip	
7- Pinion Shaft	15- Shim Ring	23- Bearing	
8- Key	16- Bearing	24- Key	



3.7- Size: K00...K20...  
Type: 03R

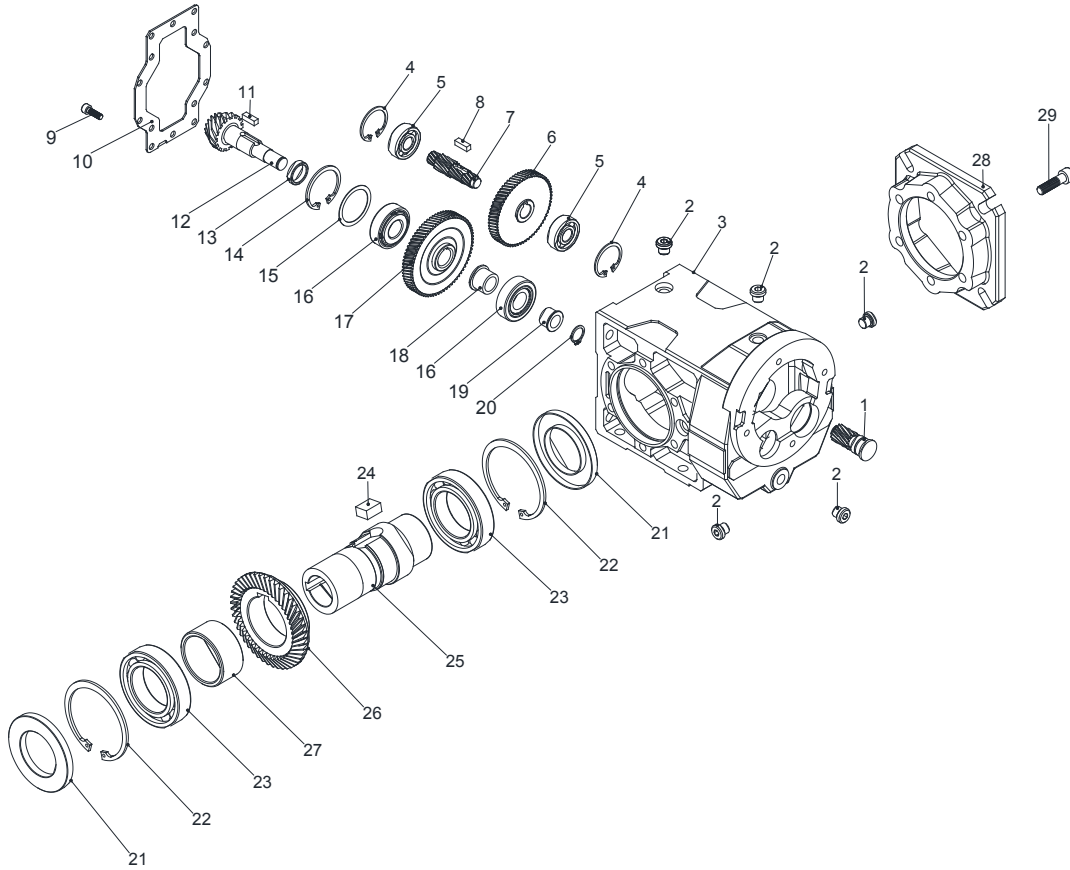

Standard types basic part diagram.  
Parts may differ for special applications.

Standard Part List

1- Pinion	9- Bolt	17- Gear	25- Output Shaft
2- Plug	10- Cover Plate	18- Spacer	26- Gear
3- Housing	11- Key	19- Spacer	27- Spacer
4- Circlip	12- Pinion Shaft	20- Circlip	28- Flange
5- Bearing	13- Shim Ring	21- Oil Seal	29- Bolt
6- Gear	14- Circlip	22- Circlip	
7- Pinion Shaft	15- Shim Ring	23- Bearing	
8- Key	16- Bearing	24- Key	



3.8- Size: K00...K20...  
Type: 04

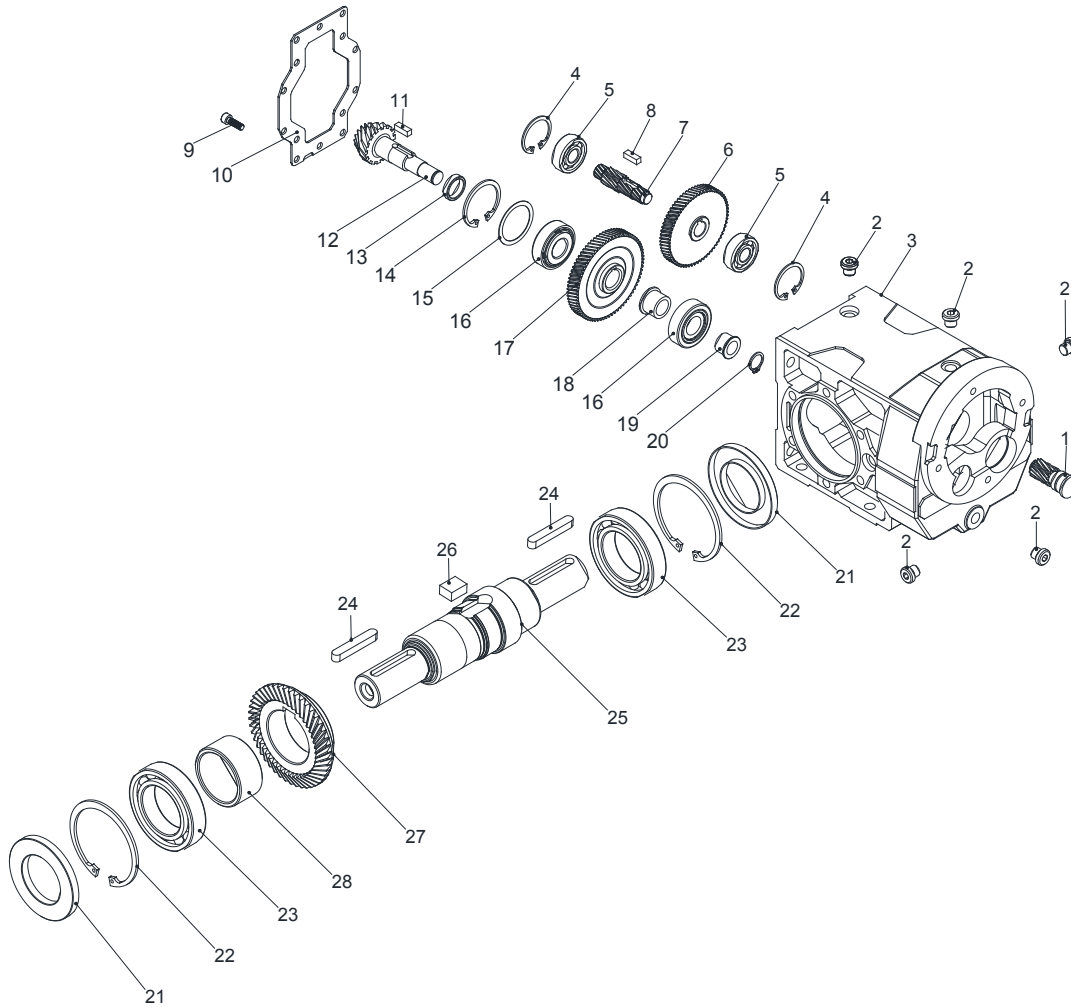

Standard types basic part diagram.  
Parts may differ for special applications.

Standard Part List

1- Pinion	9- Bolt	17- Gear	25- Output Shaft
2- Plug	10- Cover Plate	18- Spacer	26- Key
3- Housing	11- Key	19- Spacer	27- Gear
4- Circlip	12- Pinion Shaft	20- Circlip	28- Spacer
5- Bearing	13- Shim Ring	21- Oil Seal	
6- Gear	14- Circlip	22- Circlip	
7- Pinion Shaft	15- Shim Ring	23- Bearing	
8- Key	16- Bearing	24- Key	



3.9- Size: K00...K20...  
Type: 05

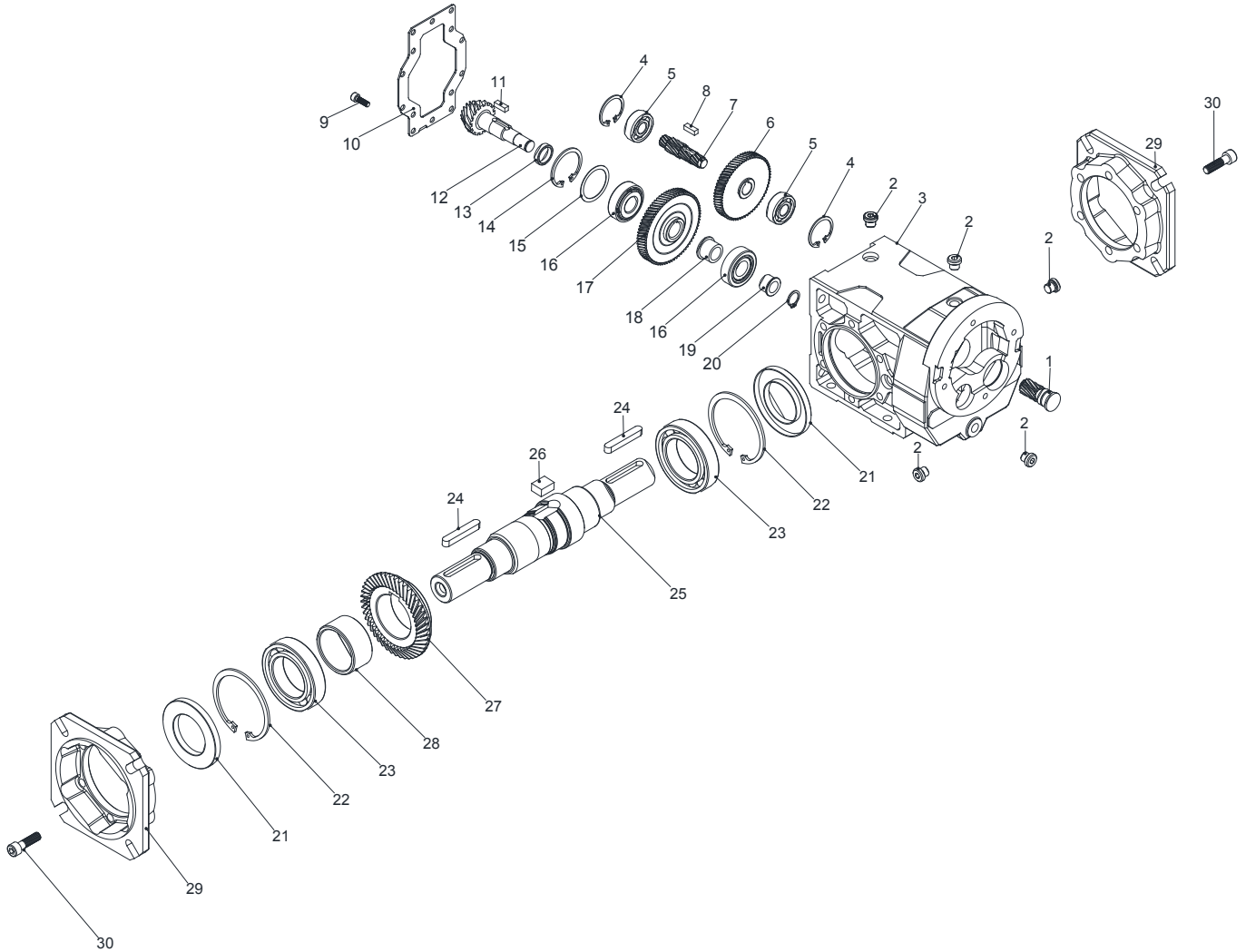

Standard types basic part diagram.  
Parts may differ for special applications.

Standard Part List

1- Pinion	9- Bolt	17- Gear	25- Output Shaft
2- Plug	10- Cover Plate	18- Spacer	26- Key
3- Housing	11- Key	19- Spacer	27- Gear
4- Circlip	12- Pinion Shaft	20- Circlip	28- Spacer
5- Bearing	13- Shim Ring	21- Oil Seal	29- Flange
6- Gear	14- Circlip	22- Circlip	30- Bolt
7- Pinion Shaft	15- Shim Ring	23- Bearing	
8- Key	16- Bearing	24- Key	



3.10- Size: K00...K20...  
Type: 08

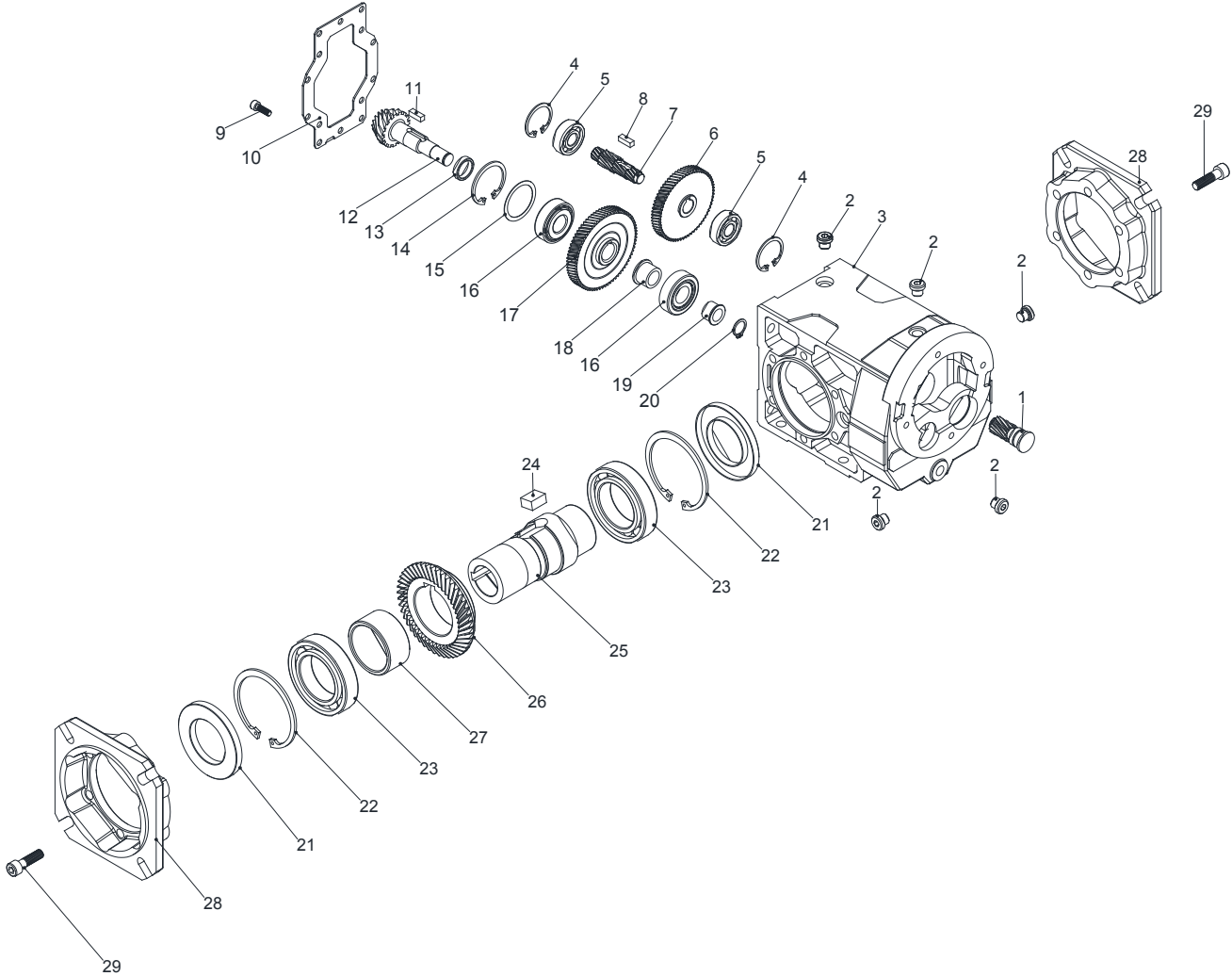

Standard types basic part diagram.  
Parts may differ for special applications.

Standard Part List

1- Pinion	9- Bolt	17- Gear	25- Output Shaft
2- Plug	10- Cover Plate	18- Spacer	26- Gear
3- Housing	11- Key	19- Spacer	27- Spacer
4- Circlip	12- Pinion Shaft	20- Circlip	28- Flange
5- Bearing	13- Shim Ring	21- Oil Seal	29- Bolt
6- Gear	14- Circlip	22- Circlip	
7- Pinion Shaft	15- Shim Ring	23- Bearing	
8- Key	16- Bearing	24- Key	





3.11- Size: K27...K87...  
Type: 00

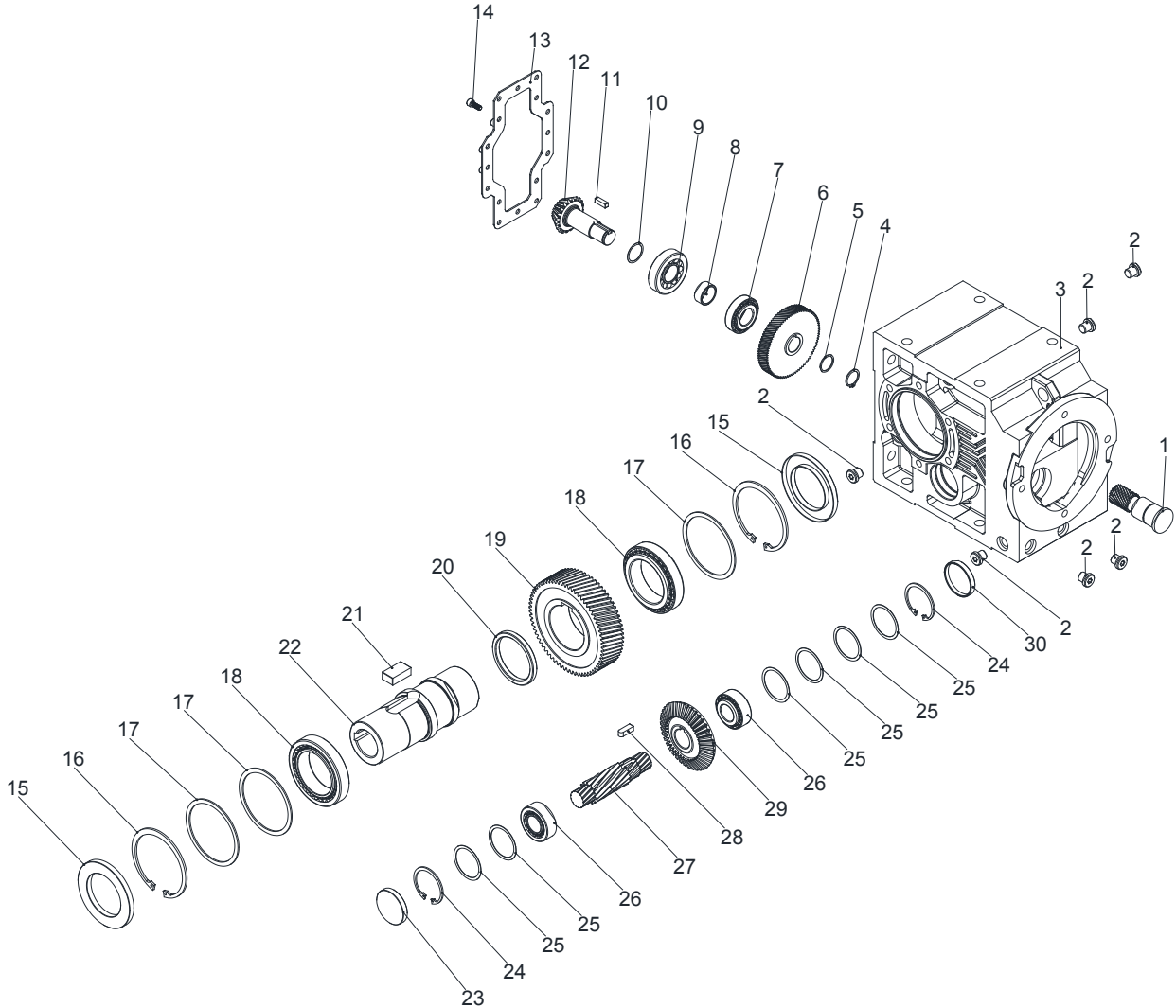

Standard types basic part diagram.  
Parts may differ for special applications.

Standard Part List

1- Pinion	9- Bearing	17- Shim Ring	25- Shim Ring
2- Plug	10- Shim Ring	18- Bearing	26- Bearing
3- Housing	11- Key	19- Gear	27- Pinion Shaft
4- Circlip	12- Pinion Shaft	20- Shim Ring	28- Key
5- Shim Ring	13- Cover Plate	21- Key	29- Gear
6- Gear	14- Bolt	22- Output Shaft	30- Shim Ring
7- Bearing	15- Oil Seal	23- Closing Cap	
8- Spacer	16- Circlip	24- Circlip	



3.12- Size: K27...K87...  
Type: 01

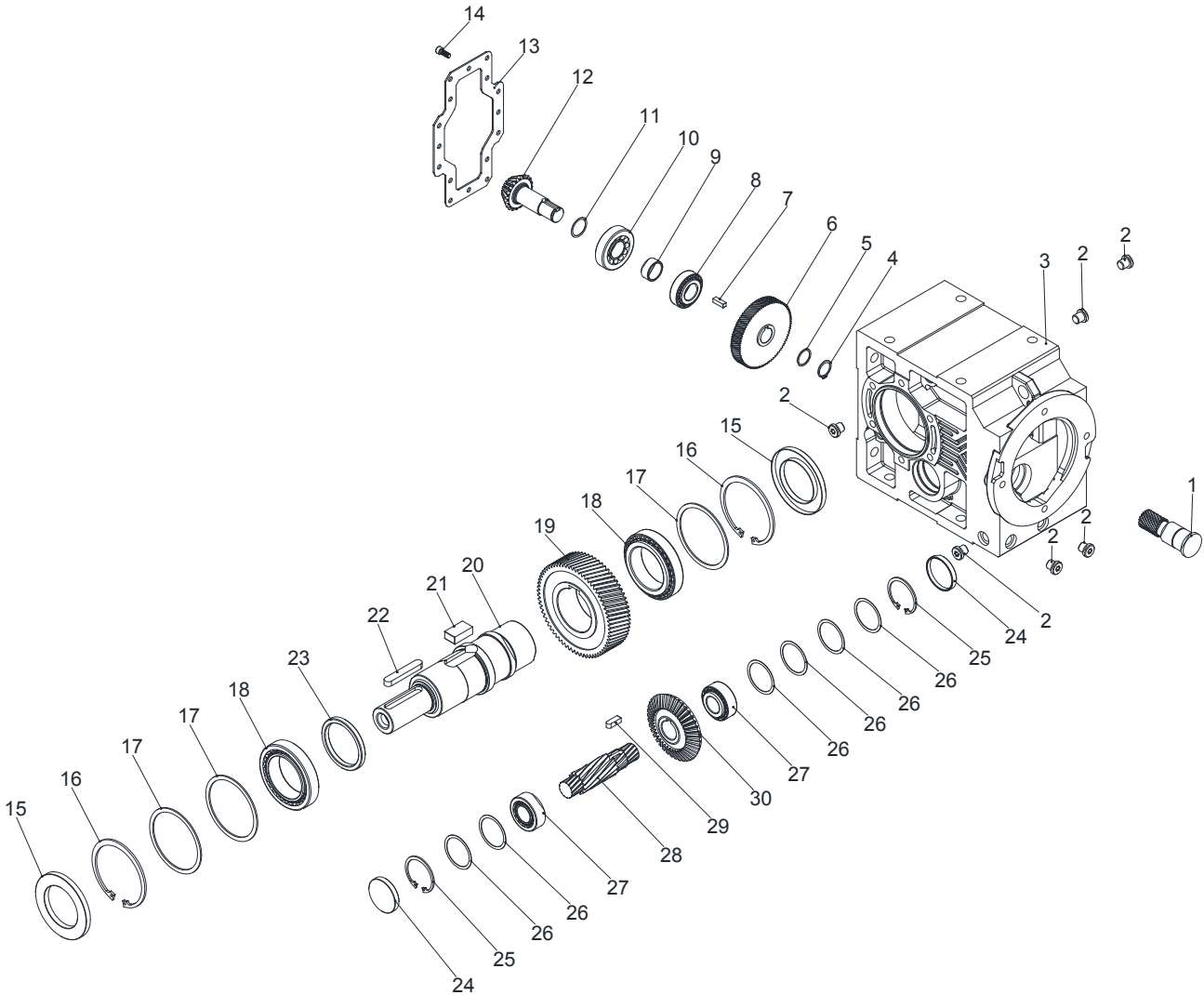

Standard types basic part diagram.  
Parts may differ for special applications.

Standard Part List

1- Pinion	9- Spacer	17- Shim Ring	25- Circlip
2- Plug	10- Bearing	18- Bearing	26- Shim Ring
3- Housing	11- Shim Ring	19- Gear	27- Bearing
4- Circlip	12- Pinion Shaft	20- Output Shaft	28- Pinion Shaft
5- Shim Ring	13- Cover Plate	21- Key	29- Key
6- Gear	14- Bolt	22- Key	30- Gear
7- Key	15- Oil Seal	23- Shim Ring	
8- Bearing	16- Circlip	24- Closing Cap	

# Operating Instructions

## K Series

### Part Designations



3.13- Size: K27...K87...  
Type: 02

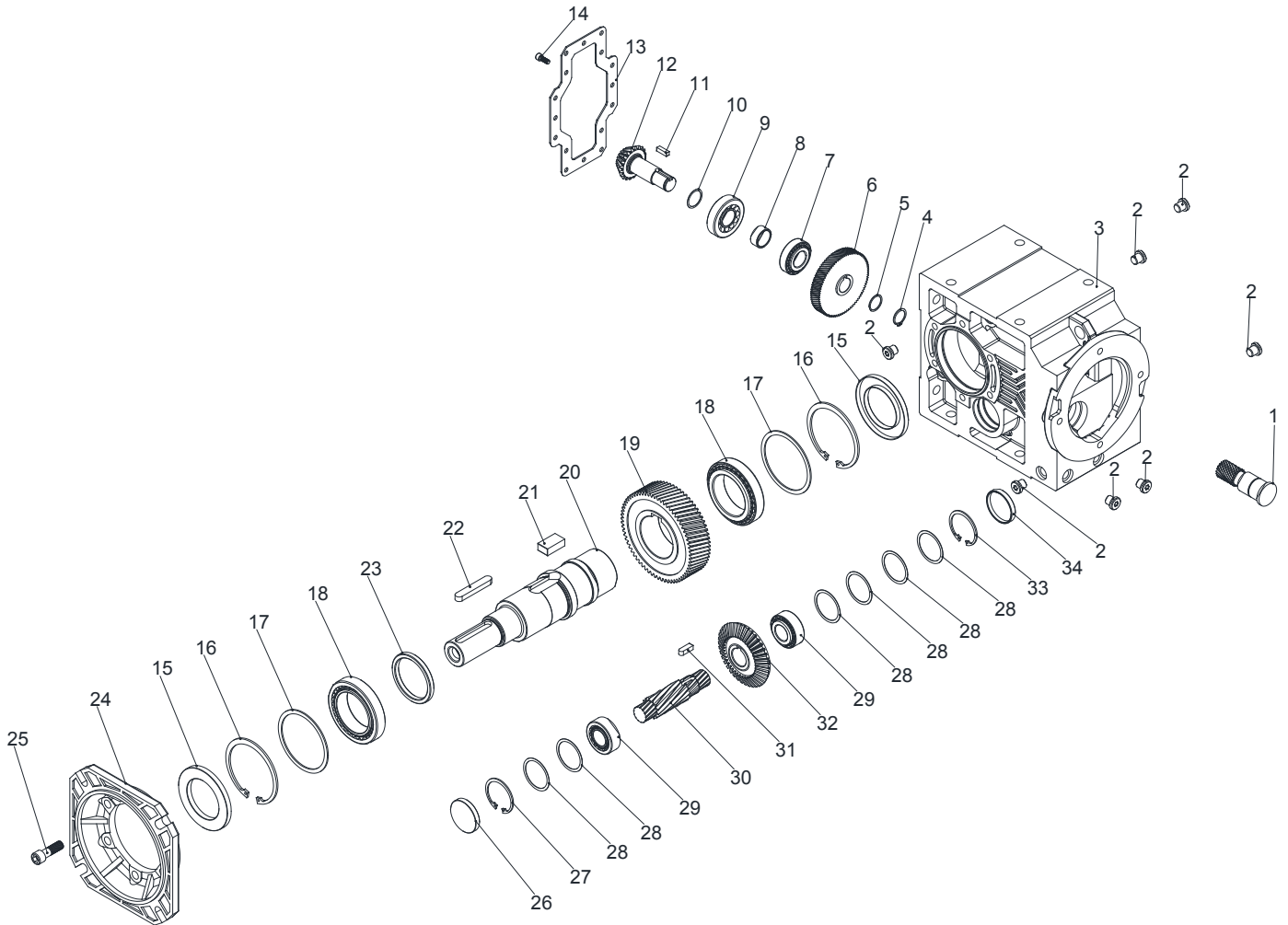

Standard types basic part diagram.  
Parts may differ for special applications.

#### Standard Part List

1- Pinion	9- Bearing	17- Shim Ring	25- Bolt	33- Circlip
2- Plug	10- Shim Ring	18- Bearing	26- Closing Cap	34- Shim Ring
3- Housing	11- Key	19- Gear	27- Circlip	
4- Circlip	12- Pinion Shaft	20- Output Shaft	28- Shim Ring	
5- Shim Ring	13- Cover Plate	21- Key	29- Bearing	
6- Gear	14- Bolt	22- Key	30- Pinion Shaft	
7- Bearing	15- Oil Seal	23- Shim Ring	31- Key	
8- Spacer	16- Circlip	24- Flange	32- Gear	



3.14- Size: K27...K87...  
Type: 03

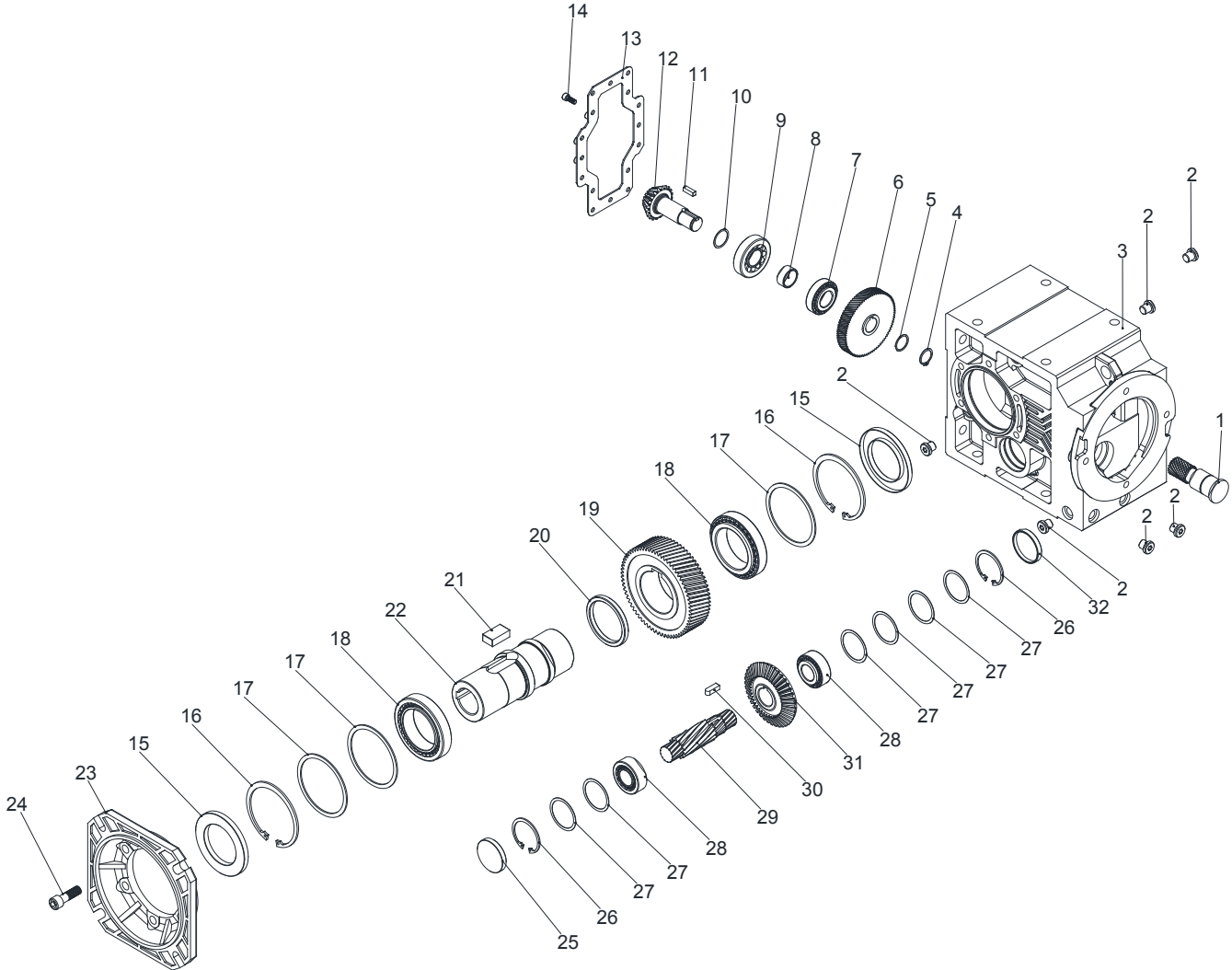

Standard types basic part diagram.  
Parts may differ for special applications.

Standard Part List

1- Pinion	9- Bearing	17- Shim Ring	25- Closing Cap
2- Plug	10- Shim Ring	18- Bearing	26- Circlip
3- Housing	11- Key	19- Gear	27- Shim Ring
4- Circlip	12- Pinion Shaft	20- Shim Ring	28- Bearing
5- Shim Ring	13- Cover Plate	21- Key	29- Pinion Shaft
6- Gear	14- Bolt	22- Output Shaft	30- Key
7- Bearing	15- Oil Seal	23- Flange	31- Gear
8- Spacer	16- Circlip	24- Bolt	32- Shim Ring

# Operating Instructions

## K Series

### Part Designations



**3.15- Size: K27...K87...**  
**Type: 04**

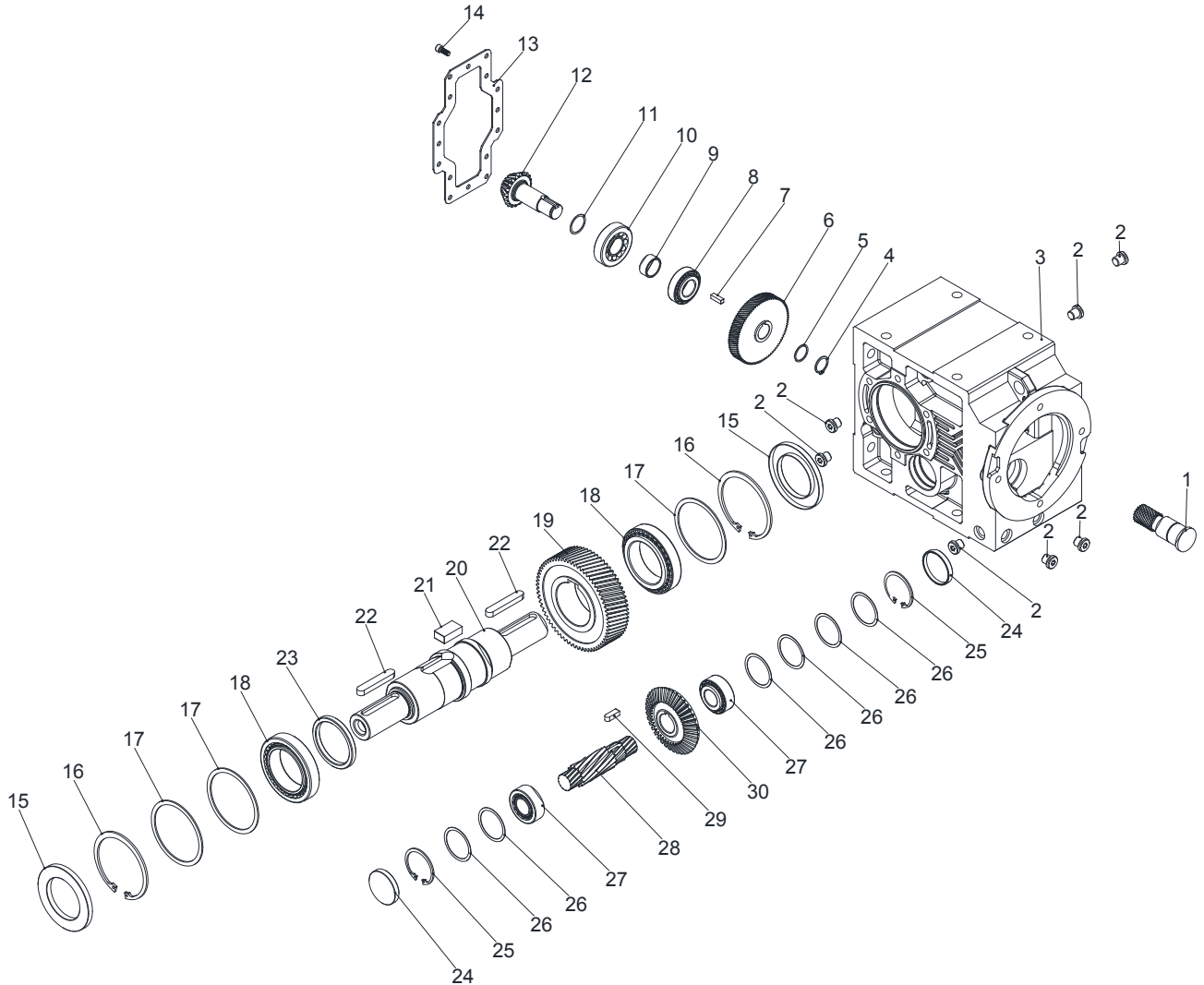

Standard types basic part diagram.  
Parts may differ for special applications.

#### Standard Part List

1- Pinion	9- Spacer	17- Shim Ring	25- Circlip
2- Plug	10- Bearing	18- Bearing	26- Shim Ring
3- Housing	11- Shim Ring	19- Gear	27- Bearing
4- Circlip	12- Pinion Shaft	20- Output Shaft	28- Pinion Shaft
5- Shim Ring	13- Cover Plate	21- Key	29- Key
6- Gear	14- Bolt	22- Key	30- Gear
7- Key	15- Oil Seal	23- Shim Ring	
8- Bearing	16- Circlip	24- Closing Cap	



3.16- Size: K27...K87...  
Type: 05

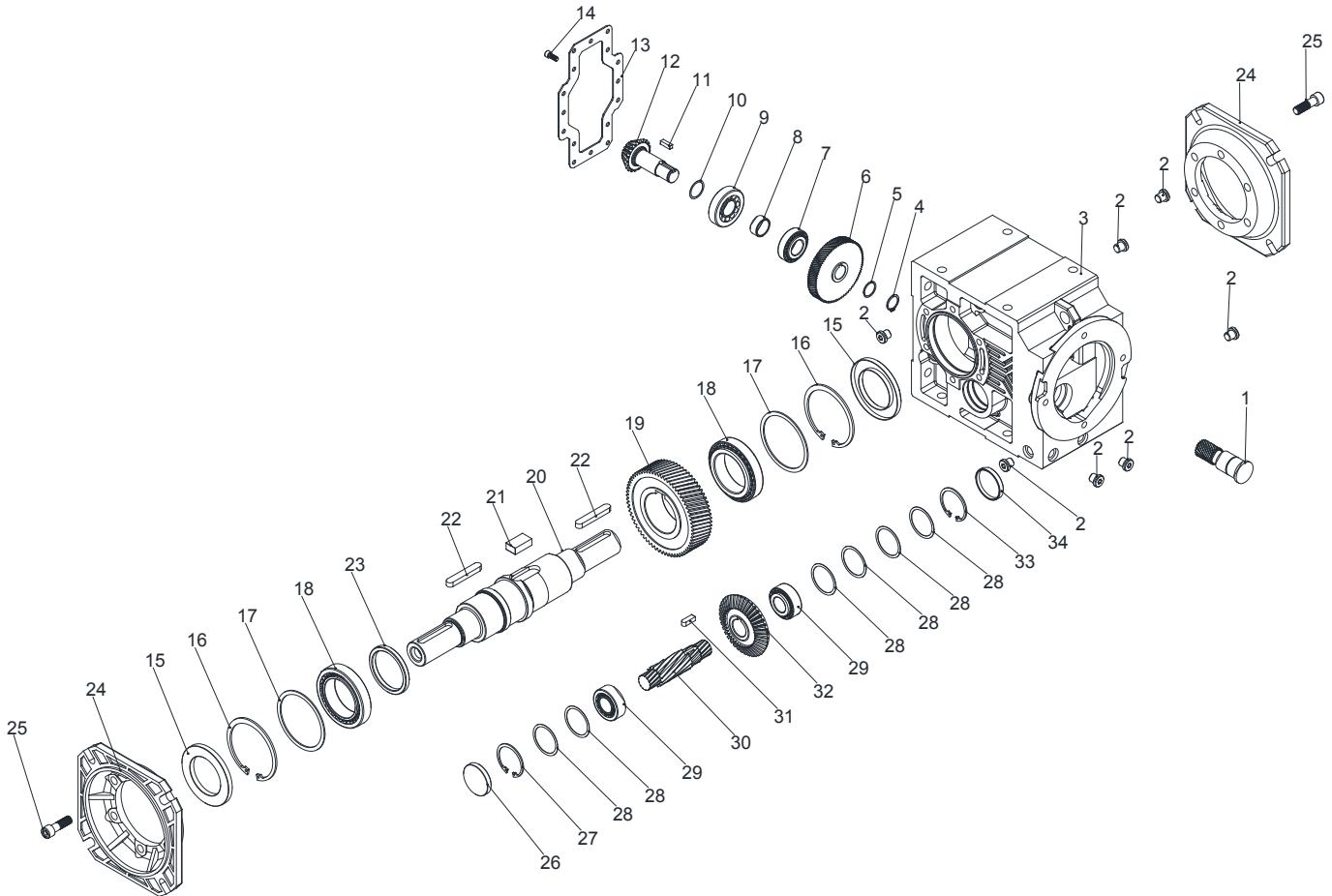

Standard types basic part diagram.  
Parts may differ for special applications.

Standard Part List

1- Pinion	9- Bearing	17- Shim Ring	25- Bolt	33- Circlip
2- Plug	10- Shim Ring	18- Bearing	26- Closing Cap	34- Shim Ring
3- Housing	11- Key	19- Gear	27- Circlip	
4- Circlip	12- Pinion Shaft	20- Output Shaft	28- Shim Ring	
5- Shim Ring	13- Cover Plate	21- Key	29- Bearing	
6- Gear	14- Bolt	22- Key	30- Pinion Shaft	
7- Bearing	15- Oil Seal	23- Shim Ring	31- Key	
8- Spacer	16- Circlip	24- Flange	32- Gear	



3.17- Size: K27...K87...  
Type: 08

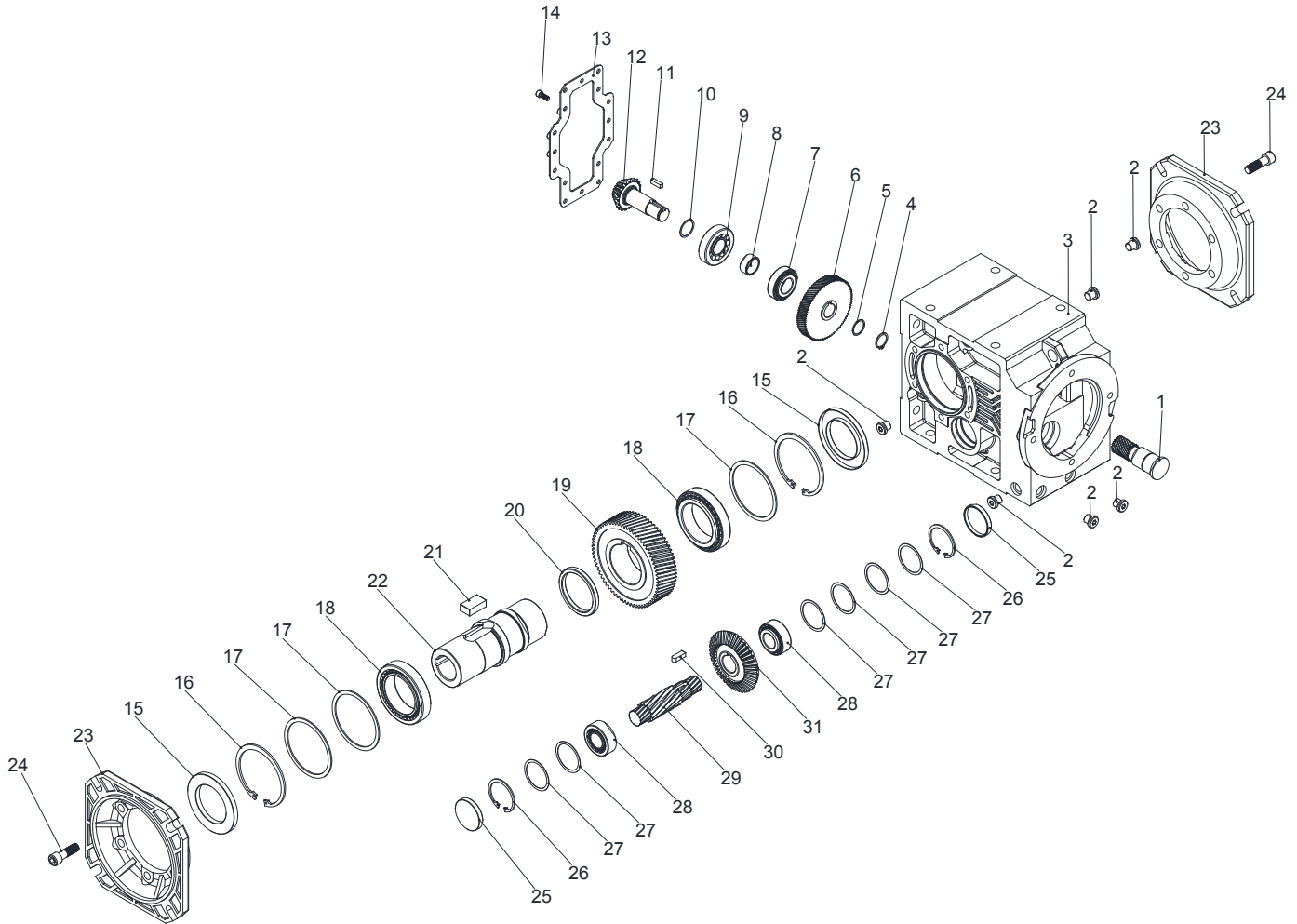

Standard types basic part diagram.  
Parts may differ for special applications.

Standard Part List

1- Pinion	9- Bearing	17- Shim Ring	25- Closing Cap
2- Plug	10- Shim Ring	18- Bearing	26- Circlip
3- Housing	11- Key	19- Gear	27- Shim Ring
4- Circlip	12- Pinion Shaft	20- Shim Ring	28- Bearing
5- Shim Ring	13- Cover Plate	21- Key	29- Pinion Shaft
6- Gear	14- Bolt	22- Output Shaft	30- Key
7- Bearing	15- Oil Seal	23- Flange	31- Gear
8- Spacer	16- Circlip	24- Bolt	



3.18- Size: K27...K87...  
Type: 0S

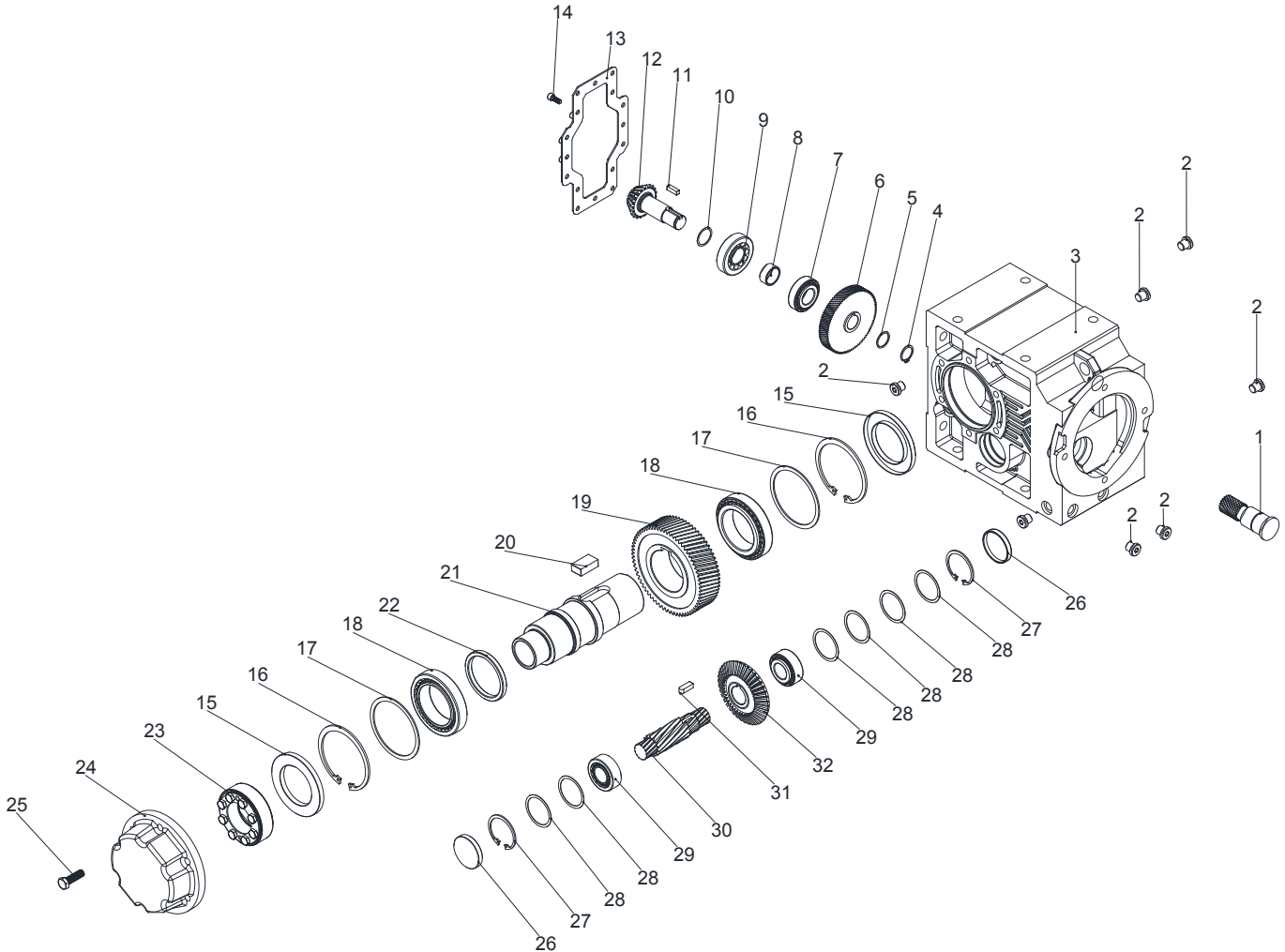

Standard types basic part diagram.  
Parts may differ for special applications.

Standard Part List

1- Pinion	9- Bearing	17- Shim Ring	25- Bolt
2- Plug	10- Shim Ring	18- Bearing	26- Closing Cap
3- Housing	11- Key	19- Gear	27- Circlip
4- Circlip	12- Pinion Shaft	20- Key	28- Shim Ring
5- Shim Ring	13- Cover Plate	21- Output Shaft	29- Bearing
6- Gear	14- Bolt	22- Shim Ring	30- Pinion Shaft
7- Bearing	15- Oil Seal	23- Shrink Disk	31- Key
8- Spacer	16- Circlip	24- Cap	32- Gear



# Operating Instructions

## K Series

### Part Designations



**3.19- Size: K27...K87...**  
**Type: 0E**

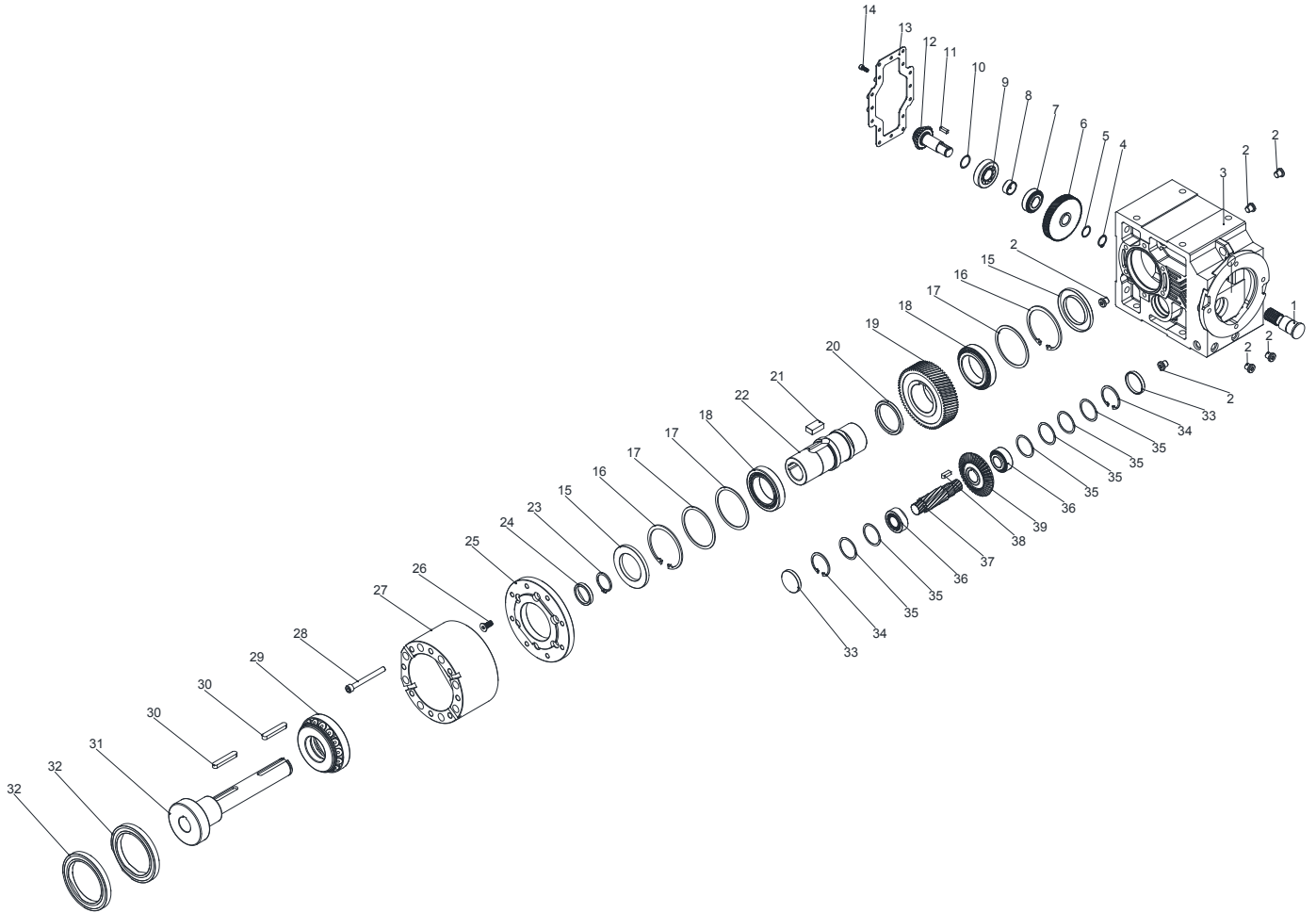

Standard types basic part diagram.  
Parts may differ for special applications.

#### Standard Part List

1- Pinion	9- Bearing	17- Shim Ring	25- Flange	33- Closing Cap
2- Plug	10- Shim Ring	18- Bearing	26- Bolt	34- Circlip
3- Housing	11- Key	19- Gear	27- Ekstruder Housing	35- Shim Ring
4- Circlip	12- Pinion Shaft	20- Shim Ring	28- Bolt	36- Bearing
5- Shim Ring	13- Cover Plate	21- Key	29- Bearing	37- Pinion Shaft
6- Gear	14- Bolt	22- Hollow shaft	30- Key	38- Key
7- Bearing	15- Oil Seal	23- Circlip	31- Shaft	39- Gear
8- Spacer	16- Circlip	24- Shim Ring	32- Oil Seal	



## 4- Safety

### 4.1- Intended Use

The gear reducer is designed for use in industrial machines. Please refer to our catalogue or our web page for the maximum permitted torques and speeds. The most important maximum permitted values are indicated on the nameplate of the product. But the all data can be found on our product catalogues. Using the product out of the product catalogue/ nameplate's permitted ranges will cancel the warranty/manufacturer declaration and YILMAZ REDÜKTÖR will not take any responsibility.

The gear units are intended for industrial machines and may only be used in accordance with the information provided in this manual the product catalogue and the nameplate of the gearbox. They comply with the applicable standards and regulations and meet the requirements of the directive 2006/42/EC. The gearbox must be started up, maintained and operated according this manual. The gearbox must be incorporated with 2006/42/EC confirming parts/machines.



A motor connected to the gear unit is only allowed to be operated in the frequency entries so that the data provided on nameplate/catalogue of the gear unit is not exceeded and is accordance with the nameplate/catalogue. The speed range will be provided on the name plate if YILMAZ REDUKTOR is informed that the gear unit will be used with frequency inverter. If not informed the nameplate will have a single fixed speed and only this speed is allowed. The electric motor and frequency inverter must be in accordance with 2006/42/EC



If the gear units input is used with variable speed gear unit, this must be informed to YILMAZ REDUKTOR before ordering and on the nameplate the allowed maximum and minimum speeds (speed range) will be provided. If not mentioned by ordering the gear units speed will be a fixed single input speed and only this speed is allowed.



If the gear unit will be driven by belt / coupling / chain drive etc. the gear unit is only allowed to be used according the nameplate/catalogue entries. Different speed, higher motor power, higher radial/axial loads etc. than nameplate/catalogue is not allowed.



The ambient temperature must be between +5 , +40 celsius and no abrasive media must attack the paint and seals. If different working conditions this must be informed to YILMAZ REDÜKTÖR before ordering.



The gearbox maintenance (oil change / check ) must be done according this manual

### 4.2-Improper Use

Every usage which exceeds the limits stated above, the nameplate and catalogue of the product (especially highest torques and speeds) is not compliant with the regulations, and thus prohibited.

The operation of the gear reducer is prohibited if;

- It was not mounted/installed according to regulations and this manual
- The gear reducer is very soiled
- It is operated without lubricant
- It is operated out of the permitted values provided on catalogues and/or nameplate



### 4.3- Safety Instructions

#### 4.3.1- General Safety Instructions

##### 4.3.1.1- Working on the gear reducer



- Inappropriately executed work can lead to injury or damage.

Make sure that the gear reducer is only installed, maintained and dismantled by trained technicians.



- Foreign bodies spinning through the air can cause grave injury.

Before putting the gear reducer into operation, check that there are no foreign bodies or tools near the gear reducer

##### 4.3.1.2- Operation



- Touching hot surfaces can lead to burns.

Do not touch the gear reducer if their operation temperatures are too high, or use suitable safety equipment like gloves.



-Rotating machinery can lead to injuries. There is danger of being trapped or pulled in!

Keep a sufficient distance and make safeguarding to rotating machinery. See relevant norms EN349+A1, EN13857.

##### 4.3.1.3- Maintenance



-An unintentional start of the machine during maintenance work can lead to serious accidents.

Make sure no one can start the machine while you are working on it.



- Even a brief running of the machine during maintenance work can lead to accidents if the safety devices are not operating.

Make sure that all safety devices are mounted and active.



##### 4.3.1.4- Lubricant

- Extended, intensive contact with oils can lead to skin irritations.

Avoid extended contact with oil, and clean oil off skin thoroughly.



- Hot oil can cause scalding.

When changing oil, protect yourself against contacting hot oil.



##### 4.3.1.5- Ambient Conditions

- Standard gearboxes are allowed to work in ambient temperatures between +5 to +40 celsius unless differently specified on the nameplate. Using the gear unit out of this range can cause damage to the gear unit or environment. Over +40 celsius ambient conditions the gear unit surface temp could be so high causing burns when touched.



-If the gear unit will be used in outdoor applications the gear unit must be prevented from rain snow and dust. Entering substances inside the gear unit from seals can damage the gear unit. Observe the safety instructions for outdoor use EN12100:2010.

#### **4.4- Tightening Torques**

All screwed connections for which a tightening torque is specified, must on principle be tightened with a calibrated torque wrench and checked. Use the following torques for the threaded bores over the gear unit housing. For connecting elements refer to the mechanical installation part.

Bolt Size	Class	Tightening Torque [Nm]
M5	8.8	5.4
M6	8.8	9
M8	8.8	23
M10	8.8	43
M12	8.8	77
M16	8.8	190
M20	8.8	370
M24	8.8	640

#### **4.5- Case of Fire**

The gear reducer itself is not combustible. However, it usually contains a synthetic or mineral gear oil.

Please observe the following if the gear reducer is situated in a burning environment

##### **4.5.1- Suitable extinguishing agents, Protective equipment**

Always keep suitable extinguishing, protective equipment like carbon dioxide, powder, foam, fog easily accessible around the gear unit.



-High temperature produce irritating steam.  
Use a protective breathing apparatus.

##### **4.5.2- Unsuitable extinguishing agents**



Do not spray with water!



## 5 -Things to Check Before the Gear Unit or Geared Motor is Installed



If gear motors are used, please also refer to the manual of the motor manufacturer.

Before you install the gearbox you have to be sure that the gearbox is arrived with the all necessary equipment and without damage. Thinks to take into consideration before you start to install the unit;

- You have received the correct operation manual of the your product.
- The gearbox and all its parts are transported without damage.
- The gearbox is stored correctly according the instructions in this manual
- You have the latest product catalogue or you have access to our web page

### 5.1- Transportation

When the goods arrive, first check for any damage. If some damage observed, immediately contact the transport company and inform about the damage. Contact YILMAZ REDÜKTÖR for the damage and do not start to install the unit until it is agreed that the damage has no affect of operation.



Use the upper foot connection holes for lifting up the gear unit by using eyebolts. The eyebolts should be capable to carry the weight of gearboxes. Do not hang additional loads on the gear box by lifting. Use suitable hoisting equipment which is capable to hold the gear units weight. Refer to the catalogue for various types weights. If the gearbox is delivered with steel carrying construction use the construction holes for lifting the gear unit. See drawing bellow for hoisting point.



Do not stay beneath / under the lifting/hoisting equipment which may cause serious injuries by falling down objects, accidental movements, unexpected accidents.



Falling or hard placement can damage the gear unit.

Only use hoisting and securing equipment which is permitted for the size / weight of your gear unit. Ensure that the load is slowly and carefully handled and placed.

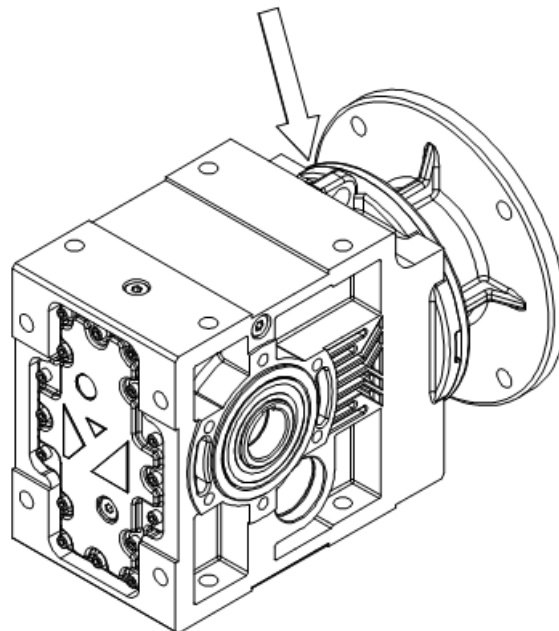



#### 5.2- Storage

If the geared unit or geared motor will be stored up to 3 years refer to the following instructions;

##### With Packing;

-Use corrosion protection oil for the output shaft and connection surfaces like flange surface or foot assembling surface. Seal the unit in a plastic wrap and pack it in container. A moisture indicator should be placed around the container to observe the moisture. Relative atmospheric humidity should not exceed 50%. The container should be kept under roof which protects from snow and rain. Under this condition the gear unit can be stored up to 3 year with regular check. The ambient temperature should be between -5 to 60 Celsius degrees

##### Without Packing;

-Use protection oil for the output shaft and connection surfaces like flange surface or foot assembling surface. If no packing is used and the gearbox is stored without packing, the ambient temperature should be between 5 to 60 Celsius degrees. The gearbox must be kept under enclosed roof with constant temperature and constant humidity not exceeding 50%. The storage should be free of dust and dirt and ventilated with filter. If the gearbox is stored without packing it is recommended not to store more than 2 years and regular check during this time is recommended.

If stored in open protect against insect damage.

## 6- Installing The Gear Unit

### 6.1- Before you start;

- Observe the gear unit for damages of storage or transportation. If any damage please contact YILMAZ REDUKTOR.
- Be sure that you have all the equipment necessary for installing like; Spanners, torque wrench, shims and distance rings, fixing devices for input and output elements, lubricant, bolt adhesive etc.



- This manual is not for 94/9/EC (ATEX) conforming gear units. For 94/9/EC conforming gear units refer to the ATEX range manual. ATEX conforming gear units have name plates indicating the zone and the temperature class and are different from standard type geared units. Therefore Standard units can not be installed on Potentially explosive atmospheres.



**6.2- Check the shaft dimensions to fit**

Type	Hollow Shaft Diameter	Hollow Shaft Tolerance (H7)	Output Shaft Diameter	Output Shaft Tolerance (DIN748) Up to 50mm k6 Over 50mm m6	Flange Centering Shoulder Diameter	Centering Shoulder Tolerance (g6)
K.00...	Ø20	+0.02 0	Ø20	+0.02 0	Ø95	-0.01 -0.03
K.10...	Ø30	+0.02 0	Ø30	+0.02 0	Ø110	-0.01 -0.03
K.20...	Ø35	+0.03 0	Ø35	+0.02 0	Ø130	-0.01 -0.04
K.27...	Ø35	+0.03 0	Ø35	+0.02 0	Ø130	-0.01 -0.04
K.37...	Ø40	+0.03 0	Ø40	+0.02 0	Ø180	-0.01 -0.04
K.47...	Ø50	+0.03 0	Ø50	+0.02 0	Ø230	-0.02 -0.05
K.57...	Ø60	+0.03 0	Ø60	+0.03 +0.01	Ø250	-0.02 -0.05
K.67...	Ø70	+0.03 0	Ø70	+0.03 +0.01	Ø300	-0.02 -0.05
K.77...	Ø90	+0.04 0	Ø90	+0.04 +0.02	Ø350	-0.02 -0.05
K.87...	Ø110	+0.04 0	Ø110	+0.04 +0.02	Ø450	-0.02 -0.06

**6.3- Check the ambient temperature;**

The ambient temperature must be between +5 celsius to +40 celsius for standart type gear units. If different contact YILMAZ REDUKTOR for special solutions.

**6.4- Check the voltage supply;**

The standard geared motors are supplied with 230/400 V 50/60Hz. up to 3kW including 3kW and 400/690 V 50/60 Hz. over 3kW and is indicated on the motors name plate unless it is differently ordered. In case of only gear unit is supplied from YILMAZ REDÜKTÖR please observe the name plate of the electric motor and the instructions of the supplier. Check the basic electric connection diagrams below. Use experienced electric technician.



Using wrong connection or voltage can damage the electric motor or environment.

# Operating Instructions

## K Series

### Checking



The following wiring diagram is for standard 230/400 V 50Hz AC electric motors. For different voltages please contact YILMAZ REDUKTOR. For gear units supplied without motor, refer to the motor manufacturers user manuel.



The electric connection must be done by experienced electric technician.

The gearbox, the motor and the brake must be grounded to prevent potential differences of earth and gearbox/motor.

Pole Number	Nominal Powers at 400V, 50Hz	
	230V ( Δ ) / 400 V ( Y )	400V ( Δ )
2 or 4	≅ 3 kW	≧ 4 kW
6	≅ 2,2 kW	≧ 3 kW
8	≅ 1,5 kW	≧ 2,2 kW
Starting Principle	Direct	Direct or Y/Δ

**Basic motor connection wiring diagram**

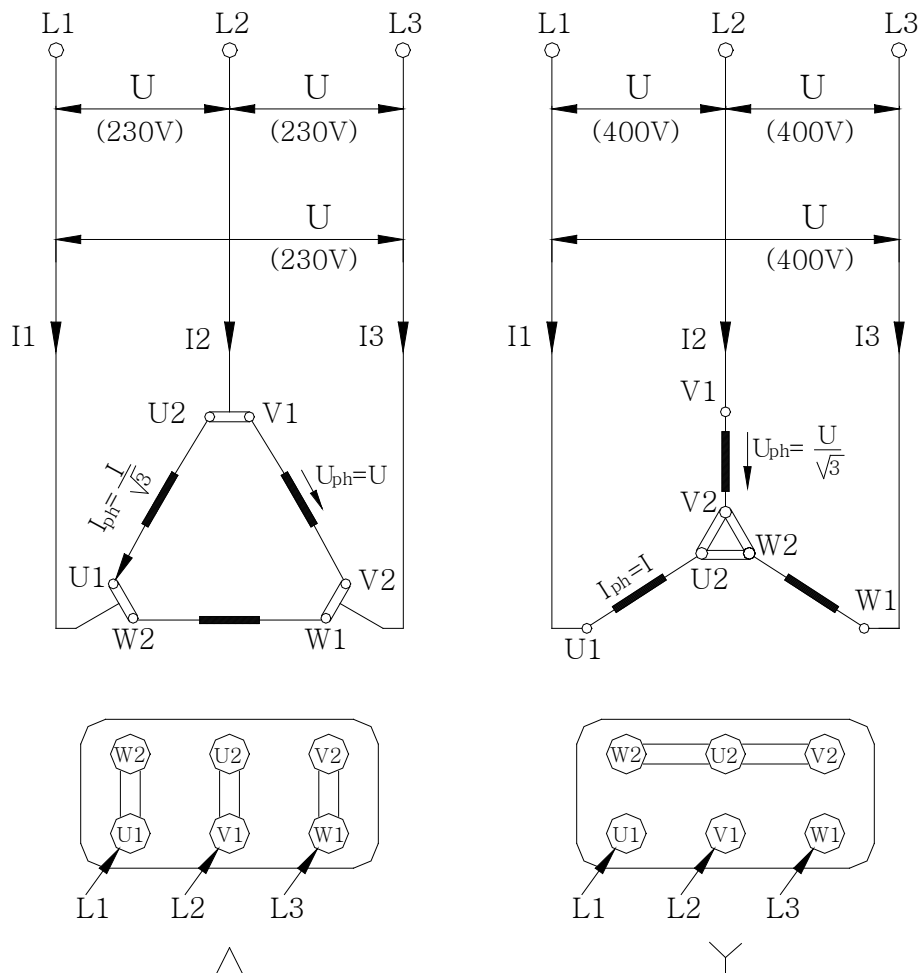





### Standard type brakes basic wiring diagram



The electric connection must be done by experienced electric technician.  
The gearbox and the motor must be grounded to prevent potential differences of earth and gearbox/motor.

Delayed Running Brake ( 220V )

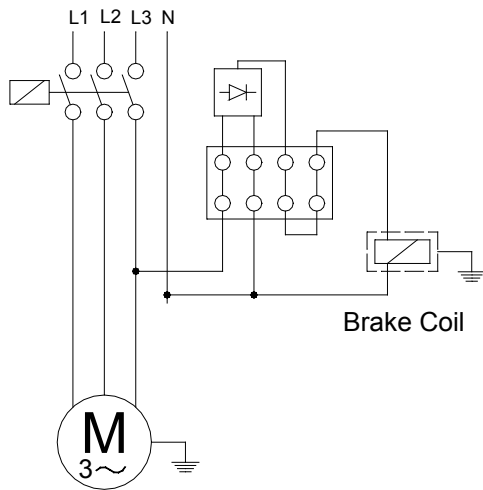

Sudden Brake ( 220 V )

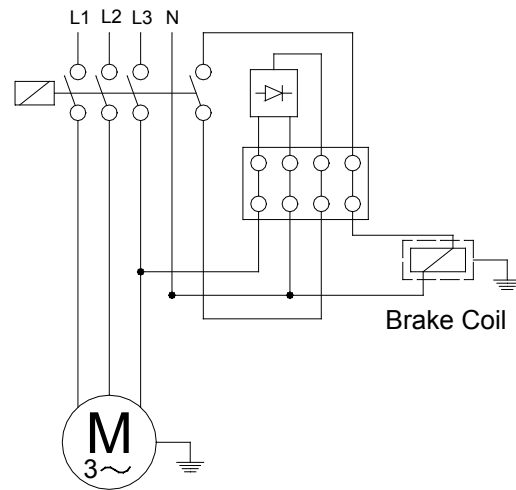

Delayed Running Brake ( 24 V )

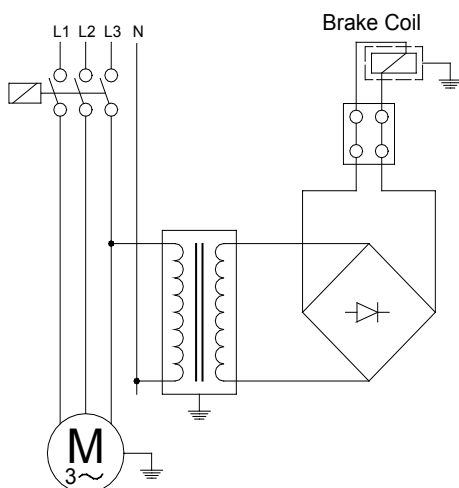

Sudden Brake ( 24 V )

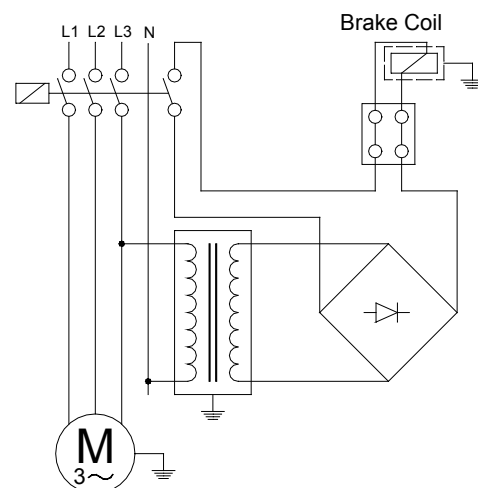



### **6.5- Check the mounting position;**



The mounting position must be in accordance with the mounting position mentioned on the name plate. If different please contact YILMAZ REDUKTOR for possibilities of using in a different mounting position. Refer to the mounting positions and oil quantities on this manual and adjust the oil level accordingly with the recommended oil types given on this manual.



Do not mix synthetic oils with mineral oils which can cause serious damage on the gear unit.

### **6.6- Use of breather plug;**

Breather plugs are not needed for K Series under normal ambient and working conditions (Up to 30 degree Celsius ambient temperature and up to 8 hours per day) . If heavy ambient conditions and long time working hours then breather plug are recommended by YILMAZ REDUKTOR and delivered with the gearbox together. Replace the breather plug with the most top plug according to your mounting position.



Some plug positions are not machined according mounting position. If no mounting position is mentioned by ordering the standard M1 position plugs are machined.

### **6.7- Check the oil level ;**

On the mounting position tables the oil level plug is shown. Please refer to those tables and be sure that the oil level is correct according the mounting position by screwing half way out the level plug and see if oil comes out from that plug. If oil comes out tighten the plug again. If no oil comes out take out the filling plug and add oil until oil comes out from the level plug and tighten both plugs after finish. Be sure you are using the correct oil mentioned on the oil tables on this manual.



Do not mix synthetic oils with mineral which can cause serious damage on the gear unit.

### **6.8- Check shaft ends and mounting faces;**

Before you start to installing be sure that all the connection elements are free of oil and dust. The output shaft may be protected by anti-corrosion oil. Please remove this using available solvents on your market. By using this do not touch sealing lips or painting of the housing.

### **6.9- Cover abrasive ambient;**

If the gear unit will be placed on a abrasive ambient be sure that the output seals are covered so that no abrasive material, chemicals or water touches the seals. Any pressure coming from outside over the seals can cause that the out staying substances to enter the gearbox and cause serious damage to the gear unit. If pressure or abrasive material can not be prevented from coming over the sealing, contact YILMAZ REDUKTÖR for solutions.



Abrasive material, chemicals, water, positive or negative pressure exceeding 0,2 bar can affect or damage the sealing lip or output shaft. Inside entering substances from the seals can cause serious damage to the gear unit.



**6.10- Check accessibility to filling, breather and drain plugs;**

The filling, breather and drain plugs must be freely accessible for further checking and service.

**7- Mechanical Installation**

The gear unit can only be installed using the supplied connection points like foot and flange assembling points.



*To install the gear unit without the supplied connection points can cause serious injuries by loosening or braking the gear unit. Even the gear unit is installed totally correctly according this manual, be sure that no one will be harmed by accidentally brake downs or loosening.*



The mounting plate must be rigid enough not allowing torsions, flat enough to prevent strains by tightening the bolts and stable enough not allowing vibrations. By using chain drives this becomes much more important because of the polygon effect on chain drives. According to your connection elements the maximal permitted radial and axial load of the gear unit must be in accordance with your application. Check the product catalogue for permitted radial loads and calculation.



*If the output or input shaft is overloaded by radial or axial loads it can cause serious damage to the gear unit.*

Secure the gear unit using 8.8 or higher quality bolts.



***Cover all the turning parts from human entering or touching. Turning parts can cause severe or fatal injuries.***

For different kind of basic installations refer to the following illustrations.



### 7.1- Installing customer shaft with shoulder

7.1.1- Use anti-seize assembling paste available in your market. Use a brush to apply the paste.

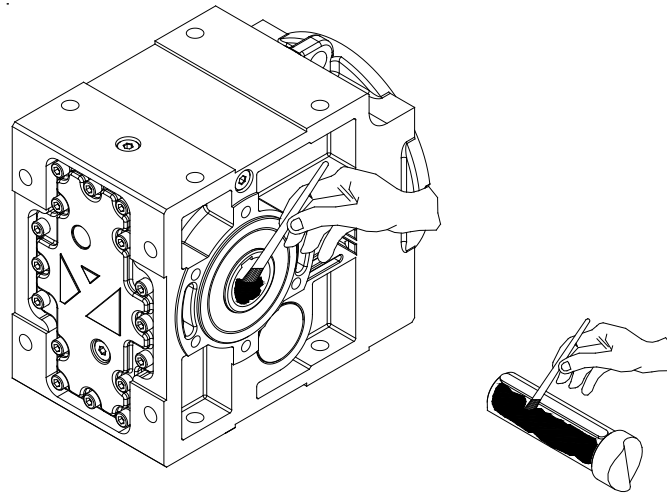

7.1.2 -Fasten the bolt as shown below.

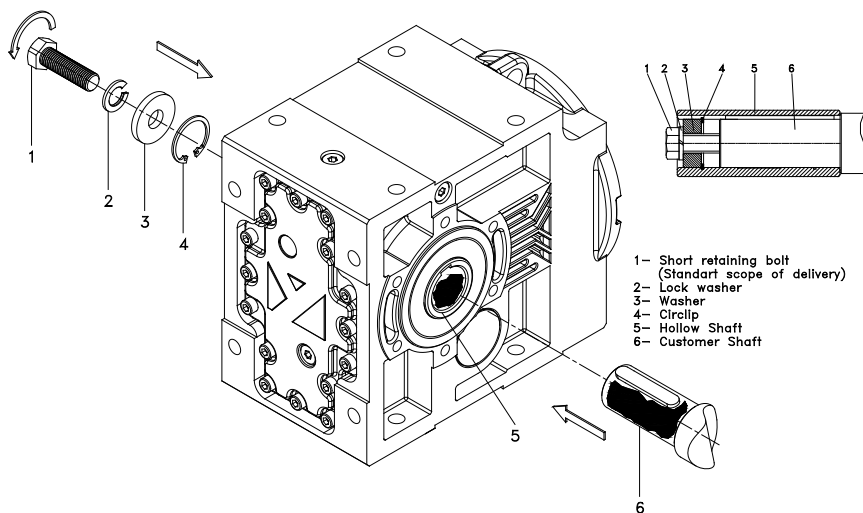



#### 7.2- Installing customer shaft without shoulder

7.2.1- Use anti-seize assembling paste available on your market. Use a brush to apply the paste.

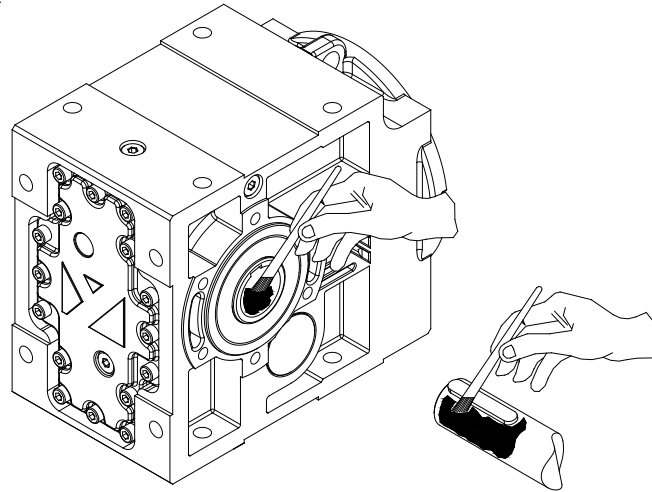

#### 7.2.2 -Fasten the bolt as shown indicated

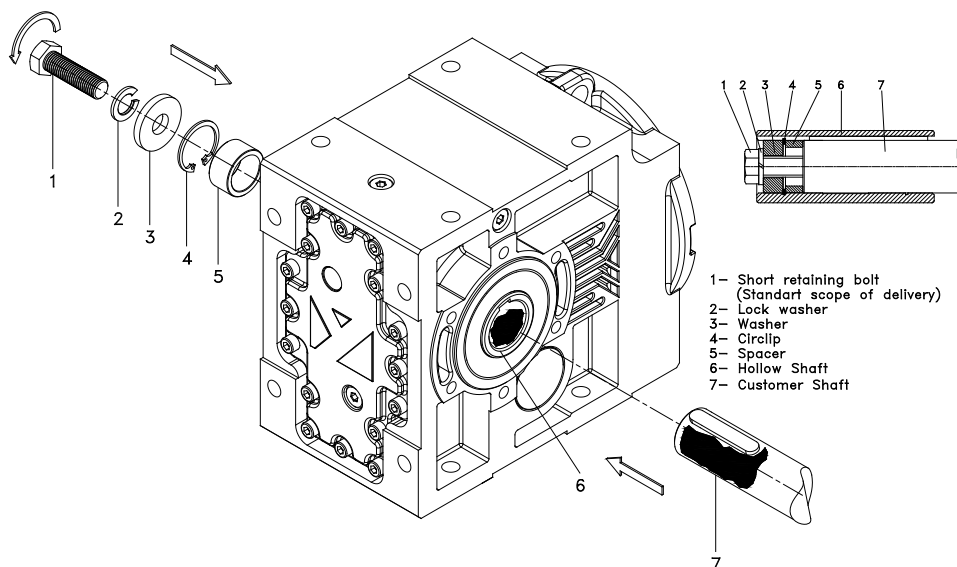



### 7.3- Disassembling customer shaft with shoulder

7.3.1- Disassemble the bolt and take out the parts as shown

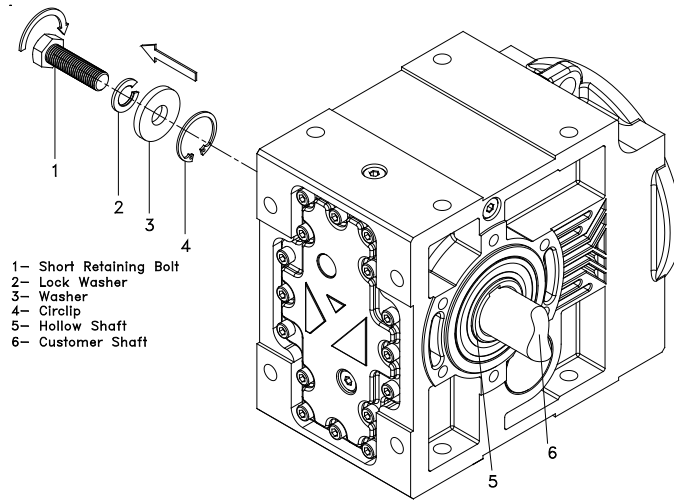

7.3.2- -Use the disassemble set from YILMAZ REDÜKTÖR and fasten the bold as shown bellow to take out the output shaft. For disassemble sets look the following pages.

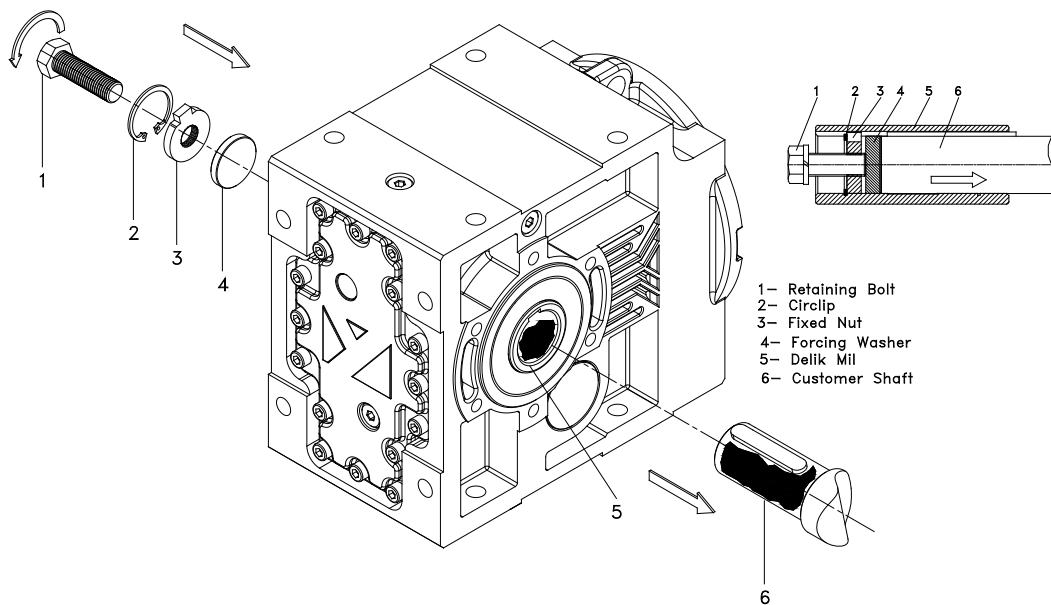



#### 7.4- Disassembling customer shaft without shoulder

##### 7.4.1- Disassembly the bolt and take out the parts as shown

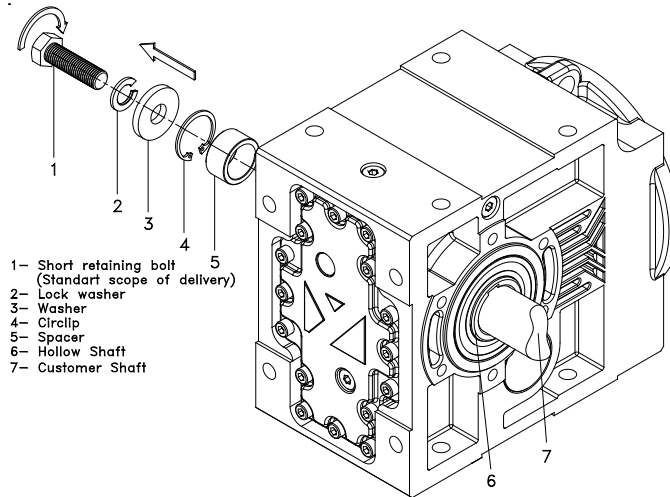

7.4.2- Use the disassembly set from YILMAZ REDÜKTÖR and fasten the bolt as shown below to take out the output shaft. For disassembly sets look the following pages.

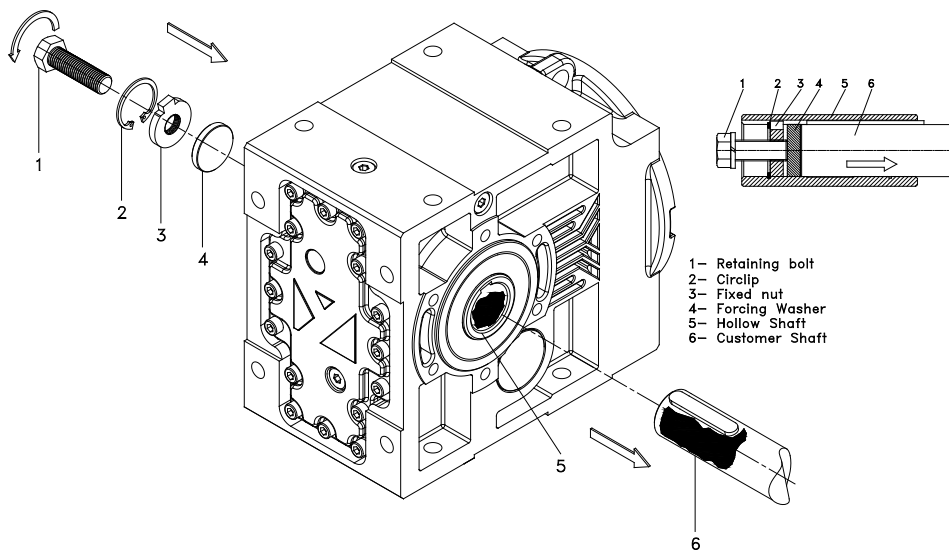



**7.5 Shaft Tightening Torques values are as shown**

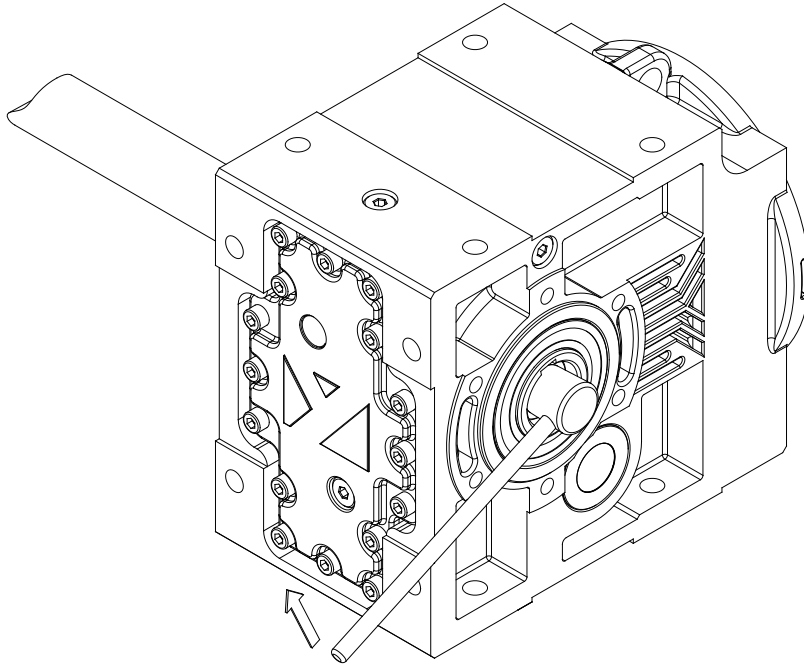

Type	Bolt	Tightening Torques [Nm]
K.00	M6	8
K.10	M10	20
K.20	M12	20
K.27	M12	20
K.37	M16	40
K.47	M16	40
K.57	M20	80
K.67	M20	80
K.77	M24	200
K.87	M24	200





7.6- Recommended shaft dimensions for KT...00 types

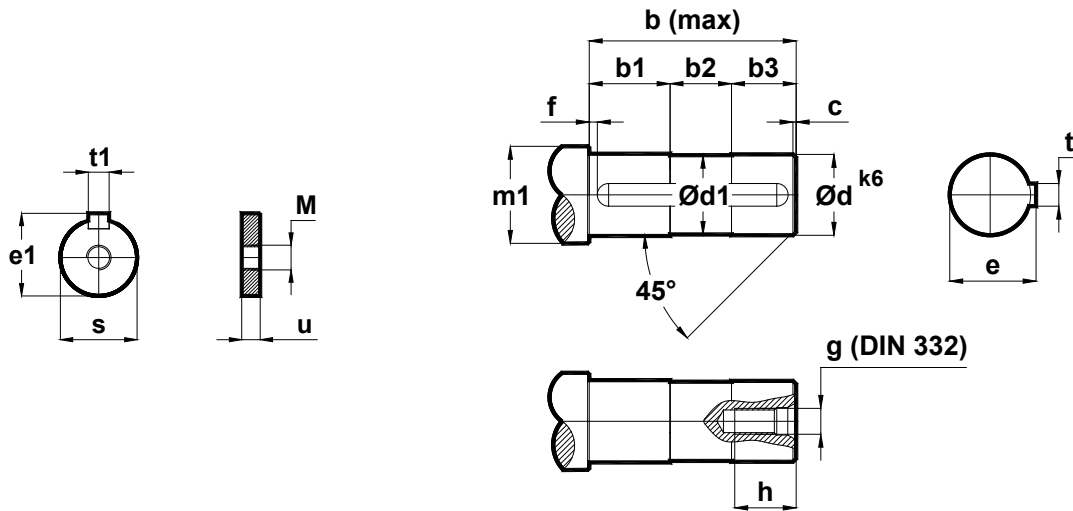

Type	s	u	e1	t1	M	d	d1	m1	f	b	b1	b2	b3	c	g	h	e	t
K.00..	19.7	10	22	5.5	M10	20	19	24	5	86	45	25	16	0.5	M6	18	22.5	6
K.10..	29.7	10	33	7.5	M12	30	29	36		90	50	20	20	1	M10	24	33	8
K.20..	34.7	12	38	9.5	M16	35	34	43		102	60	20	22	1	M12	30	38	10
K.27..	34.7	12	38	9.5	M16	35	34	43		114	65	27	22	1	M12	30	38	10
K.37..	39.7	12	43	11.5	M20	40	39	50		138	75	35	28	2	M16	38	43	12
K.47..	49.7	12	53.5	13.5	M20	50	49	60		165	87	41	37	3	M16	38	53.5	14
K.57..	59.7	16	64	17.5	M24	60	59	75		188	101	44	43	3	M20	44	64	18
K.67..	69.7	16	74.5	19.5	M24	70	69	85		248	115	78	55	4	M20	44	74.5	20
K.77..	89.7	20	95	24.5	M30	90	89	110		287	140	83	64	4	M24	52	95	25
K.87..	109.7	20	116	27.5	M30	110	109	130		347	165	98	84	4	M24	52	116	28



#### 7.7- Assembling customer shaft with shrink disk

##### 7.7.1- Loosen the bolts of the shrink disk

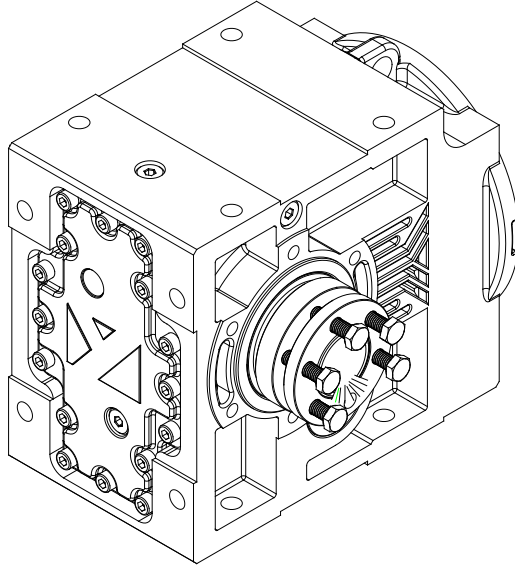

7.7.2- Use a solvent available in your market to clean all the dirt and oil from the shaft and shrink disk hollow. The surfaces must be free from oil or any dirt. The solvent must be removed from the surfaces as well.

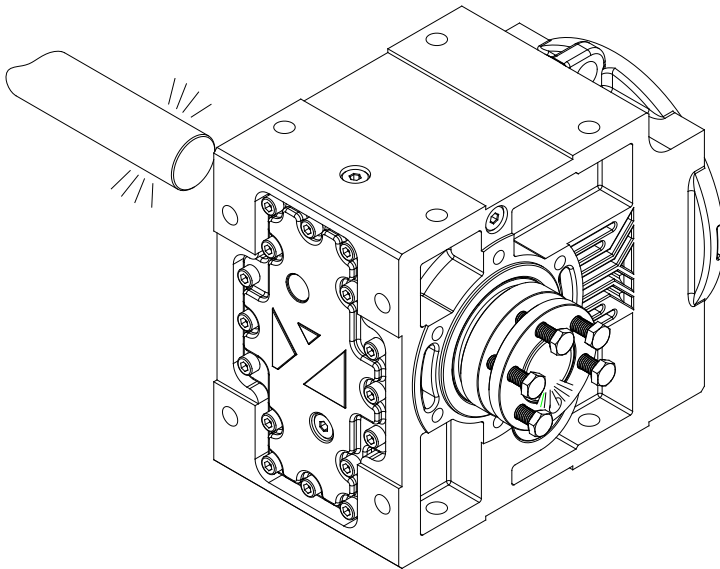



**7.7.3-** Insert the shaft and tighten the bolts as shown. Be sure that there is a clearance between the shrink disk shoulder and the hollow shaft shoulder of the gearbox.

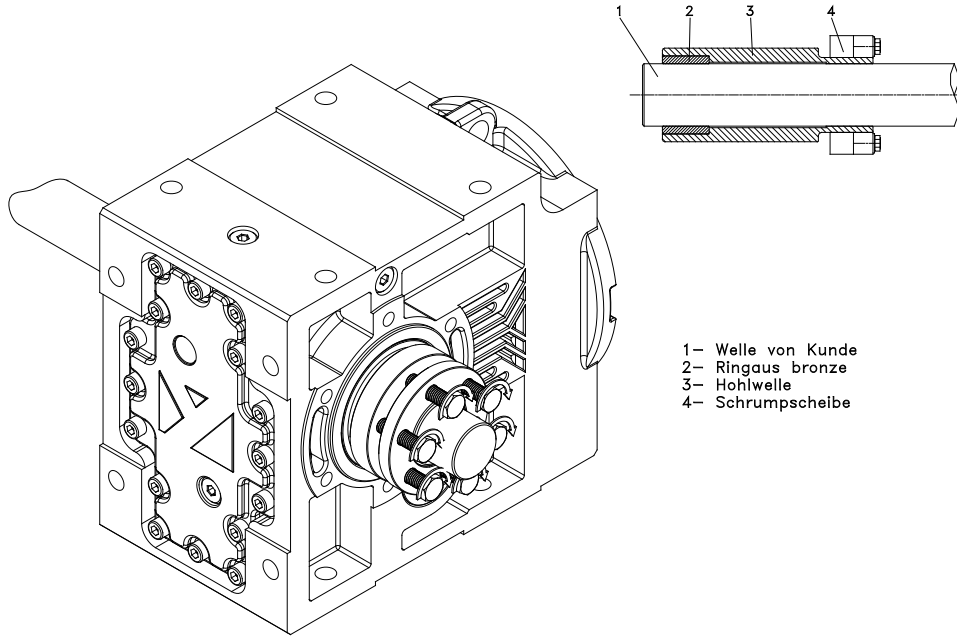

Type	Bolt	Tightening Torque [Nm]
K.00	M6	12
K.10	M8	30
K.20	M8	30
K.27	M8	30
K.37	M8	30
K.47	M8	30
K.57	M10	59
K.67	M10	59
K.77	M12	100
K.87	M14	160



**7.8- Disassembling customer shaft with shrink disk**

**7.8.1- Loosen the bolts of the shrink disk and take out the shaft.**

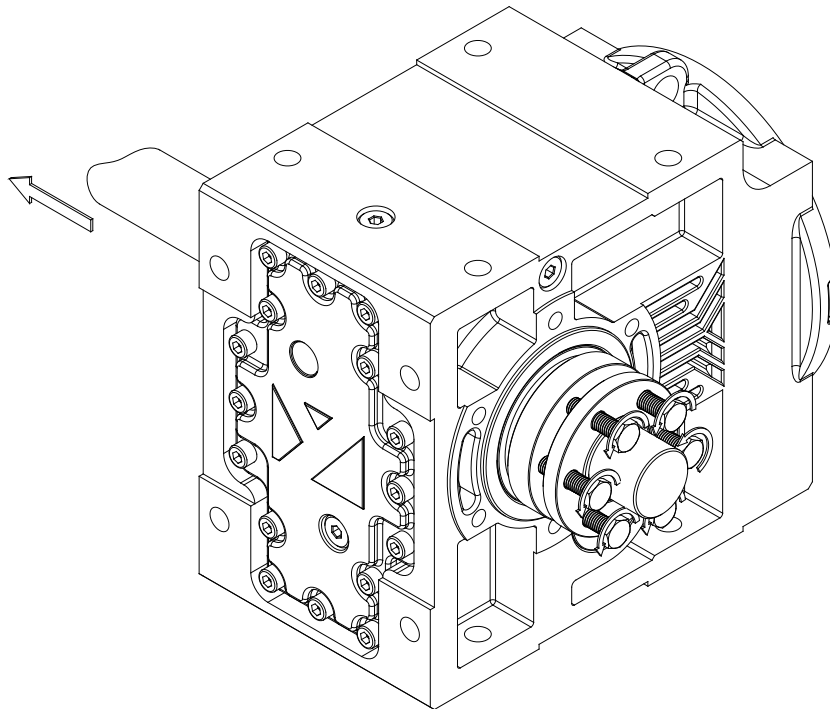



### 7.9 Assembling Gear Unit with Torque Arm

7.9.1- The following connecting possibilities are available. Use one position which is the most suitable.

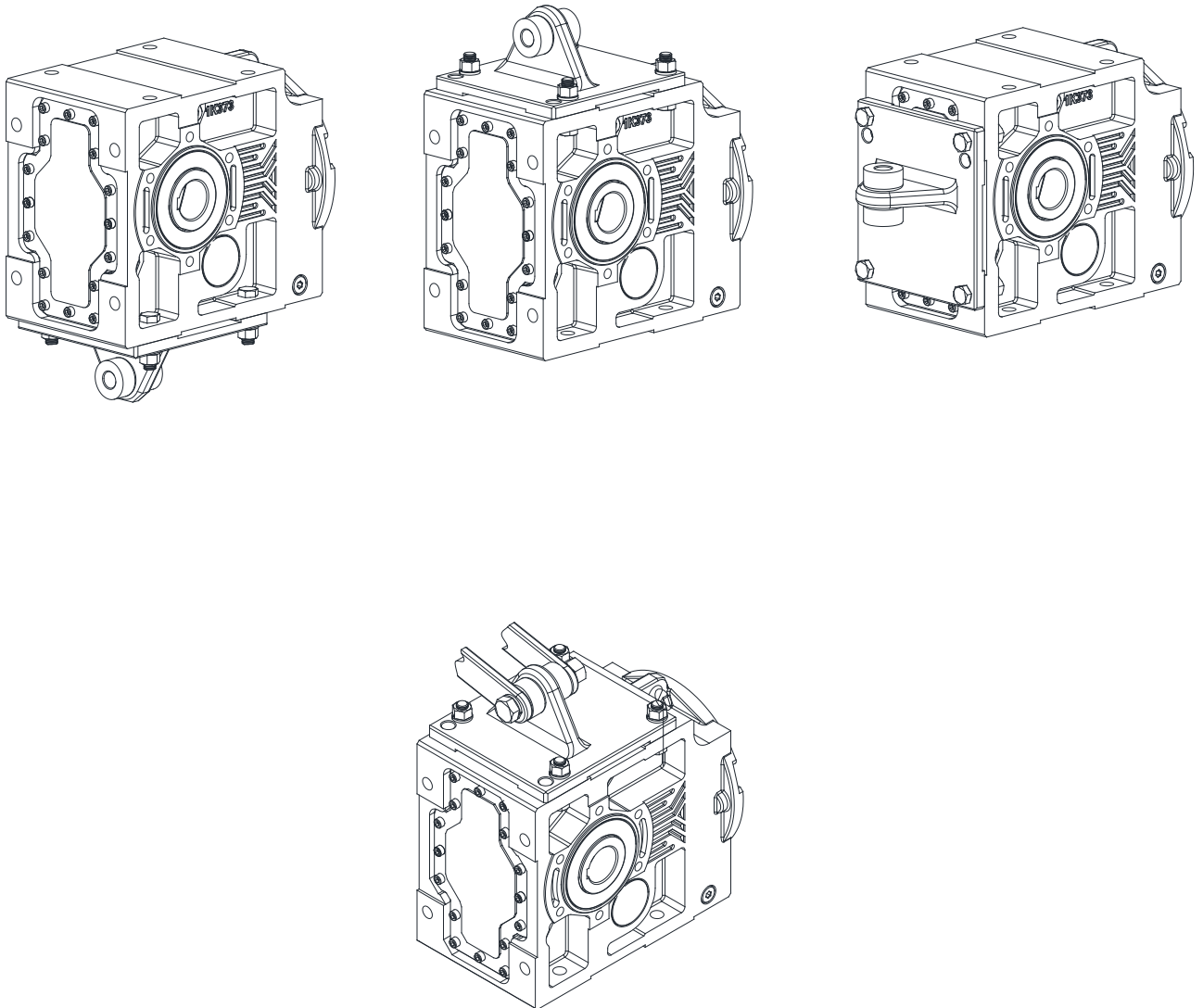



7.9.2- Assemble the parts as shown bellow

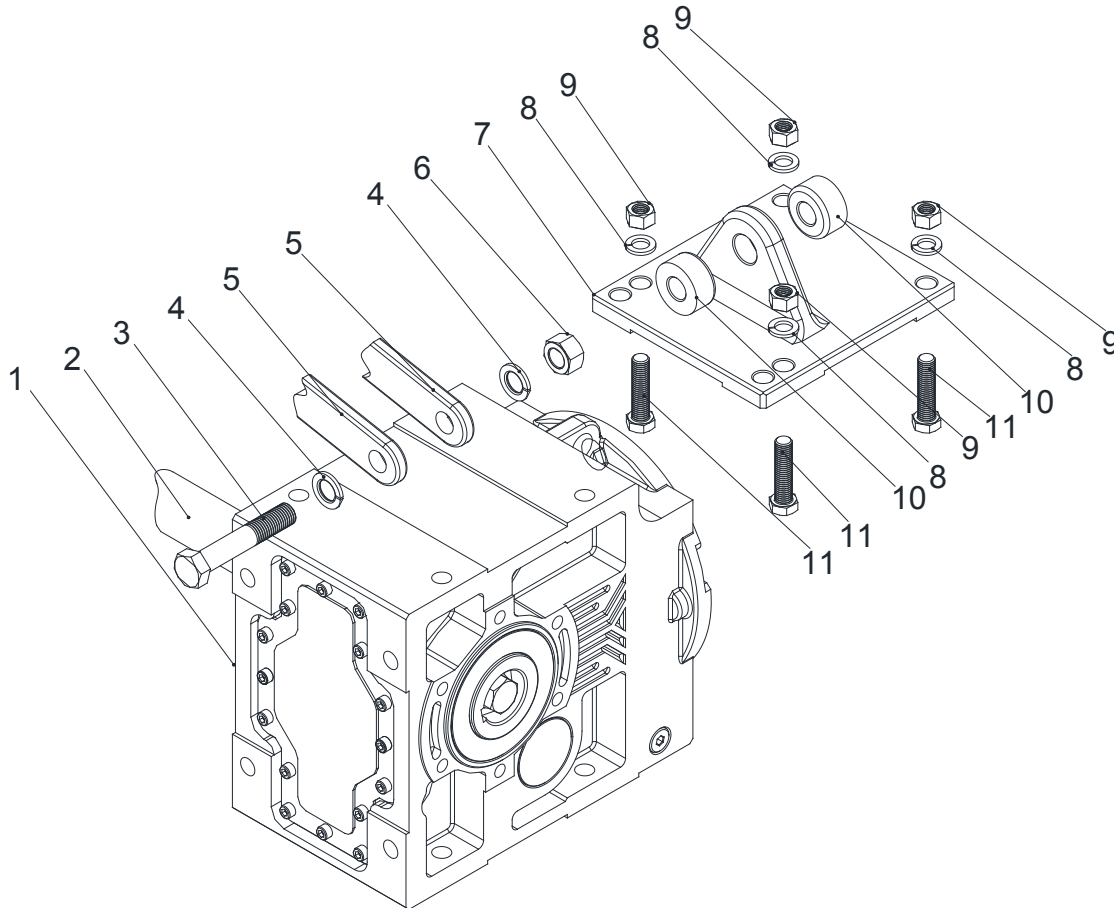

1- Gear Unit	4- Spacer Ring	7- Torque Arm	10- Rubber Buffer
2- Assembled Shaft	5- Machine Extension	8- Spacer Ring	11- Bolt
3- Bolt	6- Nut	9- Nut	



7.10- For the fixing bold position refer to the following dimensions

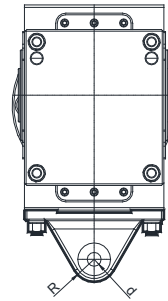
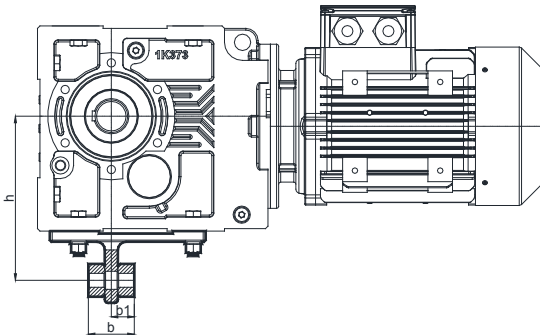

Std

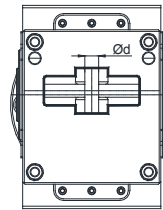
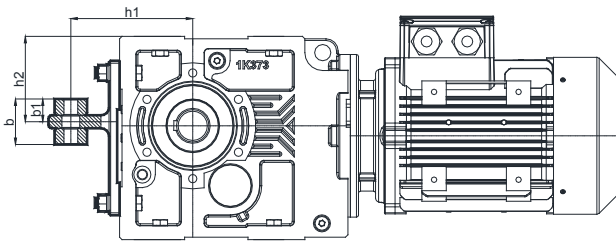

T1

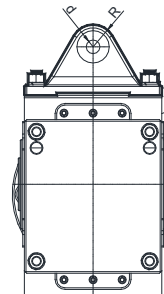
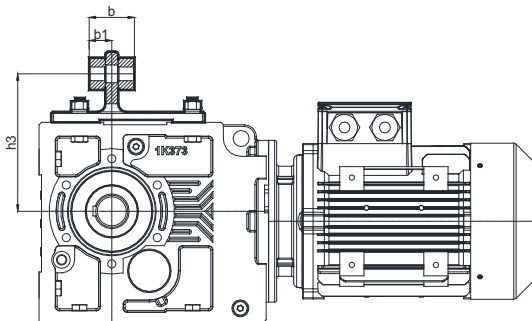

T2

Type	b	b1	d	R	Std	T1		T2
					h	h1	h2	h3
KR273.10	56	28	17	22,5	160	119	73	141
KR373.10	74	37	22	27,5	200	150	105	170
KR473.10	78	39	22	27,5	250	182	155	210
KR573.10	105	52,5	26	42,5	300	220	180	251
KR673.10	110	55	26	42,5	350	245	200	260
KR773.10	155	77,5	32	50	450	335	260	360
KR873.10	160	80	32	55	550	400	263	410



### 7.11 K.00.. - K.20.. TORQUE ARM ASSEMBLY DETAILS

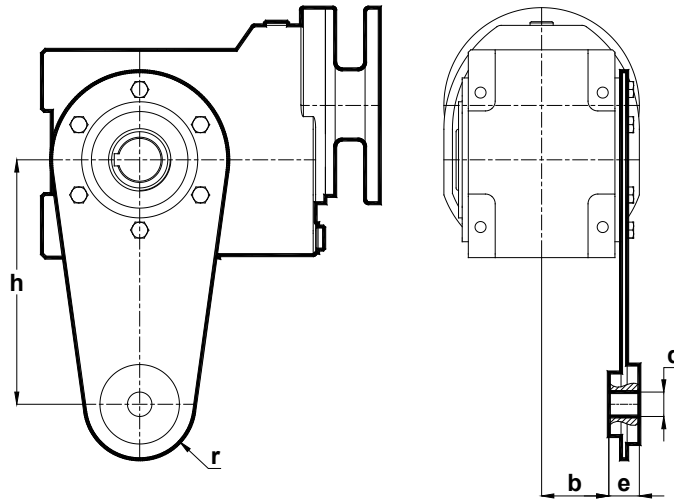

Type	b	e	d	r	h
K.00..	47	16	10	32	100
K.10..	49.5	16	10	36	150
K.20..	54.5	25	20	45	200

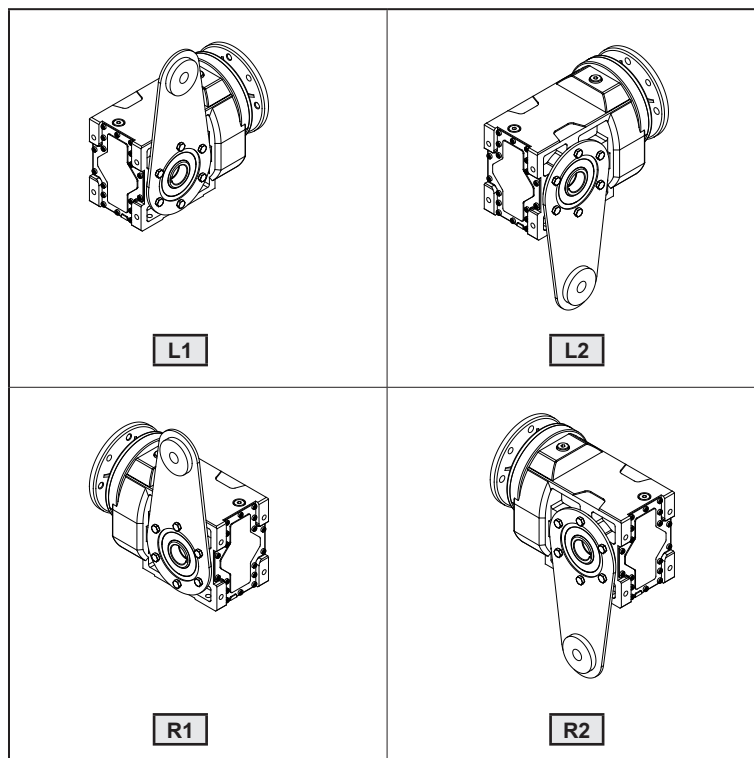





### 7.12- Fitting output shaft elements

Use the following illustration to assemble output shaft units

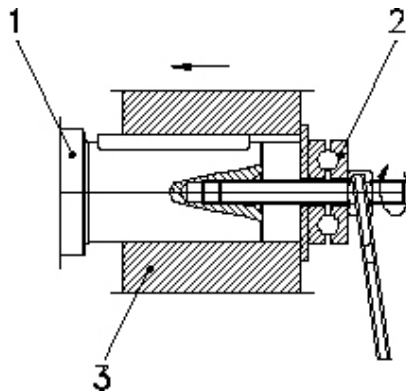

- 1) Gear shaft end
- 2) Thrust bearing
- 3) Coupling hub

### 7.13- Correct position of output shaft elements

Output Shaft unit (transmission elements) must be placed as close as possible to the gear unit so that the radial load is as close as possible to the gear unit.

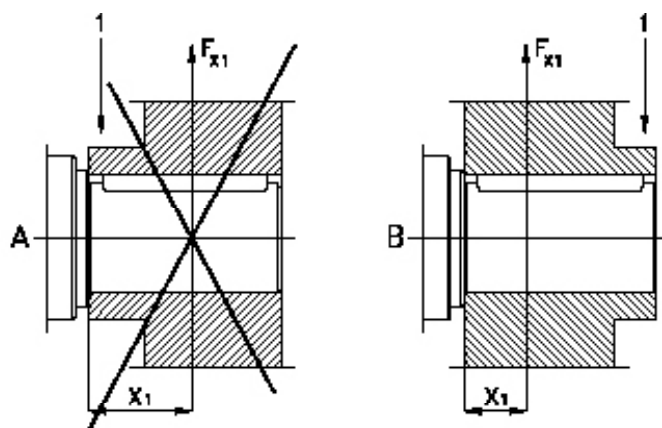

- 1) Hub



#### 7.14- Fitting Couplings

7.14.1- By fitting couplings be sure that there is some clearance between the two elements

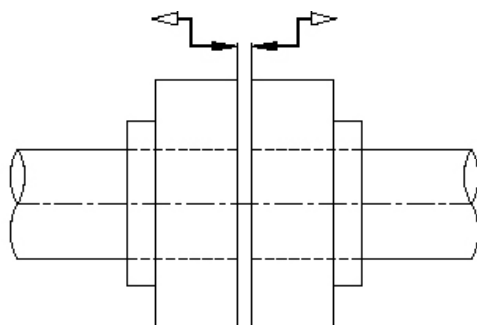

7.14.2- By fitting couplings be sure that there is no eccentricity between the two shafts.

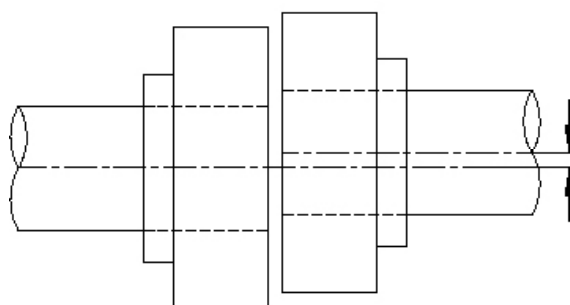

7.14.3- By fitting couplings be sure that the two shafts are not angular miss-aligned.

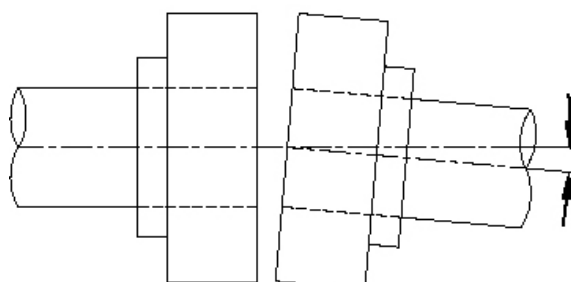



**8- Maintenance and Inspections**

Under normal ambient and working conditions the gear unit should be checked according the following intervals. (For definition of normal working conditions refer to the product catalogue: “Selecting Gearbox” section);

Item to check / replace	Every 3.000 working hours or every 6 months	Every 4.000 working hours	Every 10.000 working hours or every 3 years	Every 25.000 working hours
Check for oil leakage	x			
Check for oil level	x			
Check oil leakage from seal	x			
Check Rubber buffer	x (Change if necessary)			
Check Bearings Noise		x (Change if necessary)		
Change Mineral Oil			x (See Below for details)	
Change Synthetic-PAO Oil				x (See Below for details)
Change Sealing				x
Change Bearing Grease				x
Change Bearings				x
Check for noise Changes				x

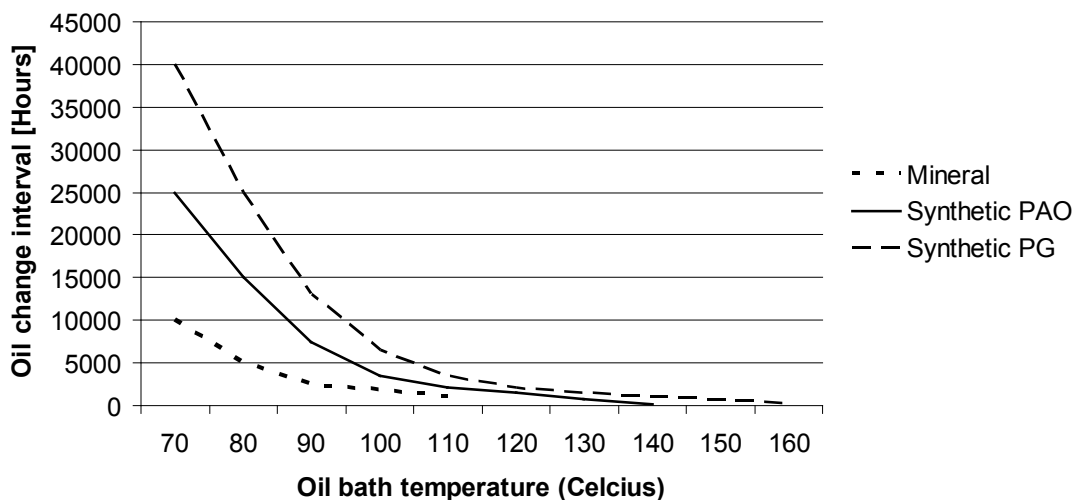

*For normal ambient conditions 70 degrees Celsius oil bath temp. should be taken as reference*

\* For K series Mineral oil is used unless it is differently ordered. For oil type and quantities refer to the following tables.



# Operating Instructions





## K Series

### Lubrication



## 9- Lubrication

### 9-1 Oil Types

Lubricant	DIN 51517-3	Ambient Temperature [°C]		ISO VG	Beyond Petroleum	Castrol	Klüber Lubrication	Mobil	Shell
		Dip Lubrication	Forced Lubrication						
Mineral Oil	CLP	0 ... +50	–	680	Energol GR-XP 680	Alpha SP 680	Klüberoil GEM 1-680 N	Mobilgear 600 XP 680	Omala 680
		-5 ... +45	–	460	Energol GR-XP 460	Alpha SP 460	Klüberoil GEM 1-460 N	Mobilgear 600 XP 460	Omala F460
		-10 ... +40	+15 ... +40	320	Energol GR-XP 320	Alpha SP 320	Klüberoil GEM 1-320 N	Mobilgear 600 XP 320	Omala F320
		<b>-15 ... +30</b>	<b>+10 ... +30</b>	<b>220</b>	<b>Energol GR-XP 220</b>	<b>Alpha SP 220</b>	<b>Klüberoil GEM 1-220 N</b>	Mobilgear 600 XP 220	<b>Omala F220</b>
		-20 ... +20	+5 ... +20	150	Energol GR-XP-150	Alpha SP 150	Klüberoil GEM1-150 N	Mobilgear 600 XP 150	Omala 150
		-25... +10	+3 ... +10	100	Energol GR-XP 100	Alpha SP 100	Klüberoil GEM 1-100 N	Mobilgear 600 XP 100	Omala 100
Synthetic Oil	CLP PG	-10 ... +60	–	680	Energyn SG-XP 680	–	Klübersynth GH 6 -680	Mobil Glygoyle 680	Tivela S 680
		-20 ... +50	–	460	Energyn SG-XP460	Aphasyn PG460	Klübersynth GH 6-460	Mobil Glygoyle 460	Tivela S 460
		-25 ... +40	+5 ... +40	320	Energyn SG-XP320	Aphasyn PG320	Klübersynth GH 6-320	Mobil Glygoyle 320	Tivela S 320
		-30 ... +30	0 ... +30	220	Energyn SG-XP 220	Aphasyn PG 220	Klübersynth GH 6-220	Mobil Glygoyle 30	Tivela S 220
		-35 ... +20	-5 ... +20	150	Energyn SG-XP 150	Aphasyn PG 150	Klübersynth GH 6 -150	Mobil Glygoyle 22	Tivela S 150
		-40 ... +10	-8 ... +10	100	–	–	Klübersynth GH 6 -100	Mobil Glygoyle 100	–
	CLP HC	-10 ... +60	–	680	–	–	Klübersynth GEM4-680 N	Mobil SHC Gear 680	–
		-20 ... +50	–	460	Energyn EP-XF 460	Alphasyn T 460	Klübersynth GEM4-460 N	Mobil SHC Gear 460	Omala HD 460
		-25 ... +40	+5 ... +40	320	Energyn EP-XF 320	Alphasyn T 320	Klübersynth GEM4-320 N	Mobil SHC Gear 320	Omala HD 320
		-30 ... +30	0 ... +30	220	Energyn EP-XF 220	Alphasyn T 220	Klübersynth GEM4-220 N	Mobil SHC Gear 220	Omala HD 220
		-35 ... +20	-5 ... +20	150	Energyn EP-XF 150	Alphasyn T 150	Klübersynth GEM4-150 N	Mobil SHC Gear 150	Omala HD 150
		-40 ... +10	-8 ... +10	100	–	–	Klübersynth GEM4-100 N	Mobil SHC 627	–
Food Grade Oil	CLP NSF H1	-15 ... +25	+5 ... +25	320	–	Optileb GT 320	Klüberoil 4 UH1-320 N	Mobil SHC Cibus 320	Cassida Fluid GL-320
Biodegradable Oil	CLP E	-25 ... +40	+5 ... +40	320	–	Tribol BioTop 1418-320	Klübersynth GEM 2-320	–	–
Mineral Grease [ -20 .... +120 Working Temperature °C ]					Energrease LS 3	Spheerol AP3	Centoplex 2 EP	Mobilux EP 3	Alvania RL3
Synthetic Grease [ -30 .... +100 Working Temperature °C ]					Energrease SY 2202	–	Petamo GHY 133 N	Mobiltemp SHC100	Cassida RLS 2



### 9.2- Changing the oil



Refer to the nameplate to find out the correct oil filled inside the gearbox.

-Do not mix synthetic oils with mineral oils which will cause serious damage to the gear unit.  
The oil change must be done by using the filling, draining and level plugs according the mounting position illustrated in section 9.4.



- Extended, intensive contact with oils can lead to skin irritations.

Avoid extended contact with oil, and clean oil off skin thoroughly.

- Hot oil can cause scalding. When changing oil, protect yourself against contacting hot oil.

#### 9.3.1-K.00. - K.20. Two - Three Stage Helical-Bevel Geared Gearboxes Oil Level Plugs

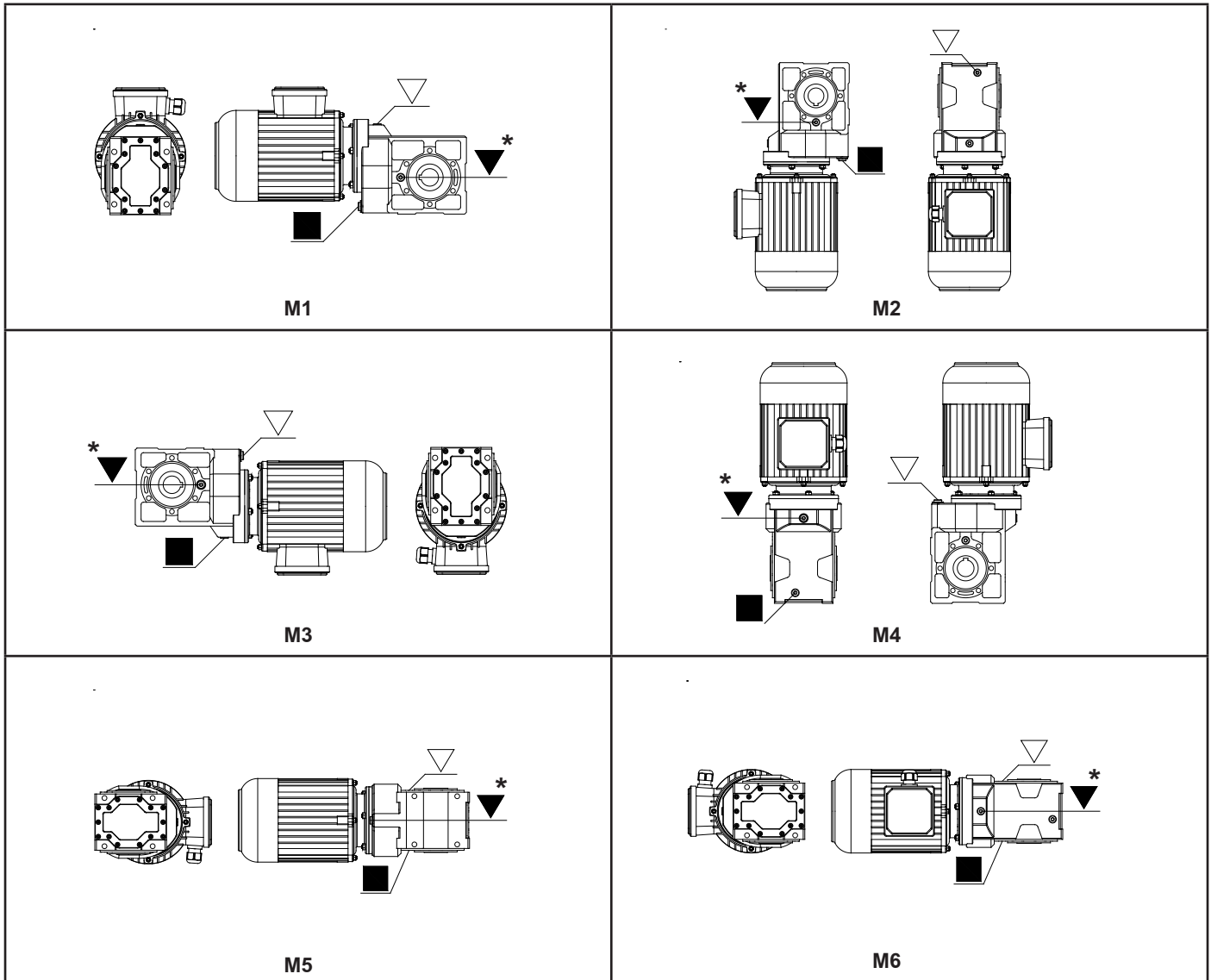

\*: For K002 and K003 this plug doesn't exist. Please refer to oil quantities.

#### Oil Quantities (lt)

Type	M1	M2	M3	M4	M5	M6
K.00.	0.3	0,6	0,5	0.8	0.65	0.65
K.10.	0.55	0.8	0.85	1.1	0.8	0.8
K.20.	1.0	1.35	1.5	1.7	1.4	1.4

Symbols : ■ : Drain plug

▽ : Oil Filling and Vent plug

▼ : Oil level

# Operating Instructions

## K Series

### Lubrication



#### 9.3.2 Three Stage K Series Oil Level Plugs

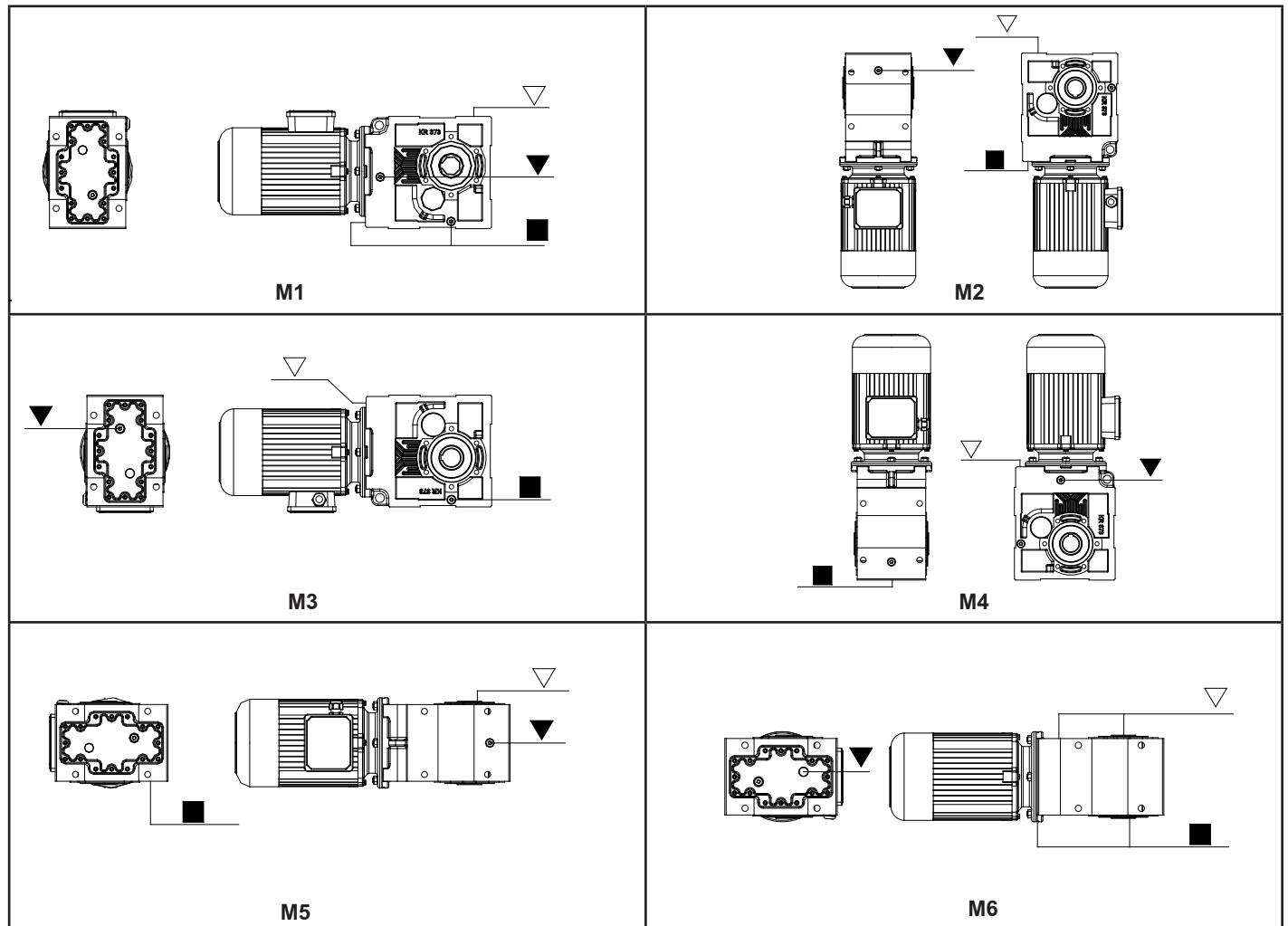

Oil Quantities (lt)

Type	M1	M2	M3	M4	M5	M6
K.273	1,3	2,0	2,0	2,1	1,5	1,3
K.373	2,1	3,3	3,2	3,7	2,4	2,8
K.473	5,0	6,5	6,0	7,0	4,8	5,5
K.573	6,5	9,5	9,5	10	7,5	8,0
K.673	15	19	19	22,5	18	17
K.773	21	31	29	34	25	21
K.873	37	50	50	60	45	39

Symbols : ■ : Drain plug

▽ : Oil Filling and Vent plug

▼ : Oil level



### 9.3.3 Four Stage K Series Oil Level Plugs

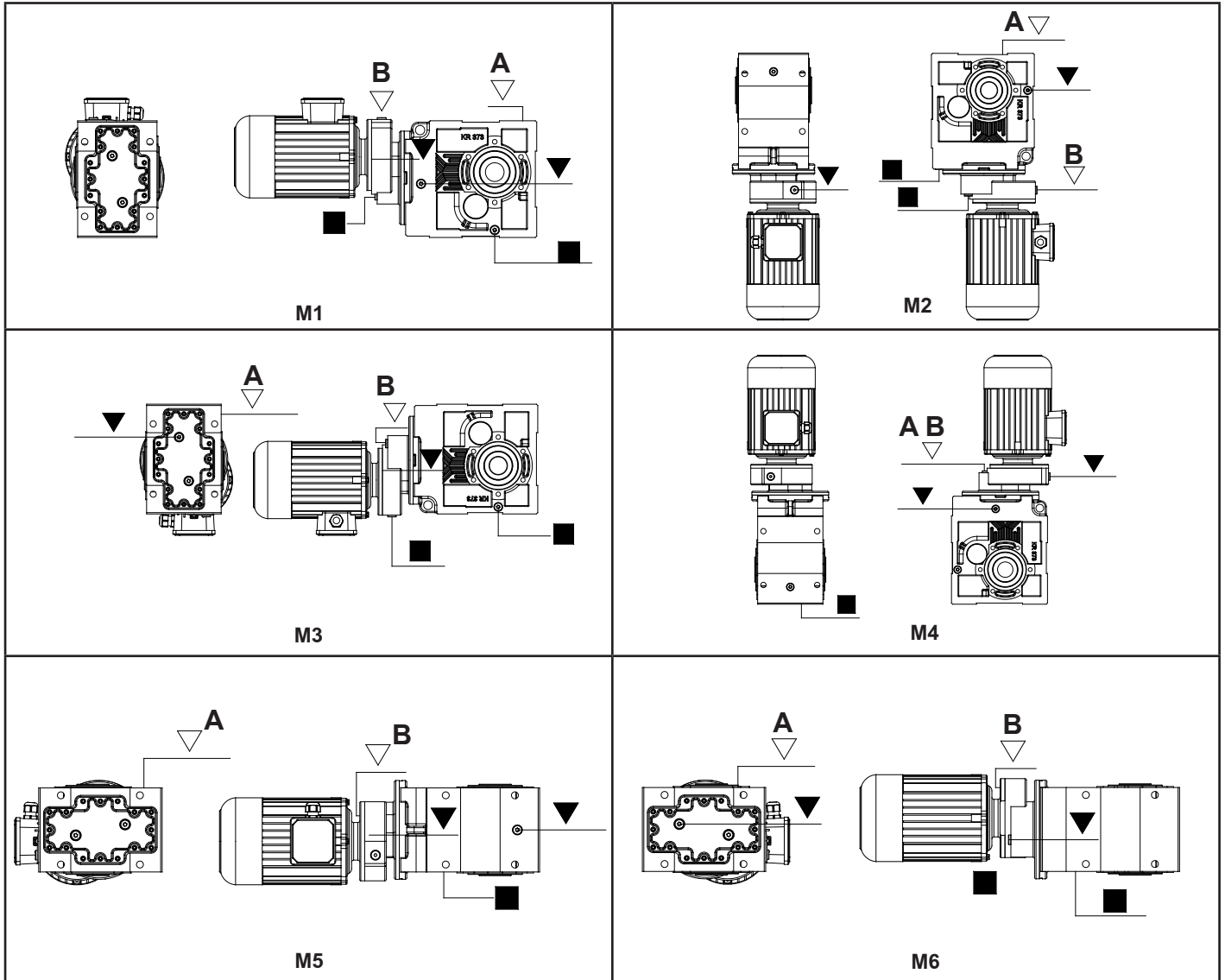

Oil Quantities (lt)

Type	M1 A / B	M2 A / B	M3 A / B	M4 A / B	M5 A / B	M6 A / B
K.374	2,1 / 0,25	3,3 / 0,25	3,2 / 0,25	3,7 / 0,25	2,4 / 0,25	2,8 / 0,25
K.474	5,0 / 0,4	6,5 / 0,4	6,0 / 0,4	7,0 / 0,4	4,8 / 0,4	5,5 / 0,4
KR574	6,5 / 0,5	9,5 / 0,5	9,5 / 0,5	10,0 / 0,5	7,5 / 0,5	8,0 / 0,5
K.674	15,0 / 0,9	19,0 / 0,9	19,0 / 0,9	20,5 / 0,9	18,0 / 0,9	17,0 / 0,9
K.774	21,0 / 1,0	29,0 / 1,0	29,0 / 1,0	34,0 / 1,0	25,0 / 1,0	21,0 / 1,0
K.874	37,0 / 2,15	50,0 / 2,15	50,0 / 2,15	60,0 / 2,15	45,0 / 2,15	39,0 / 2,15

Symbols : : Drain plug

: Oil Filling and Vent plug

: Oil level





### 9.3.4 Five-Six Stage K Series Oil Level Plugs

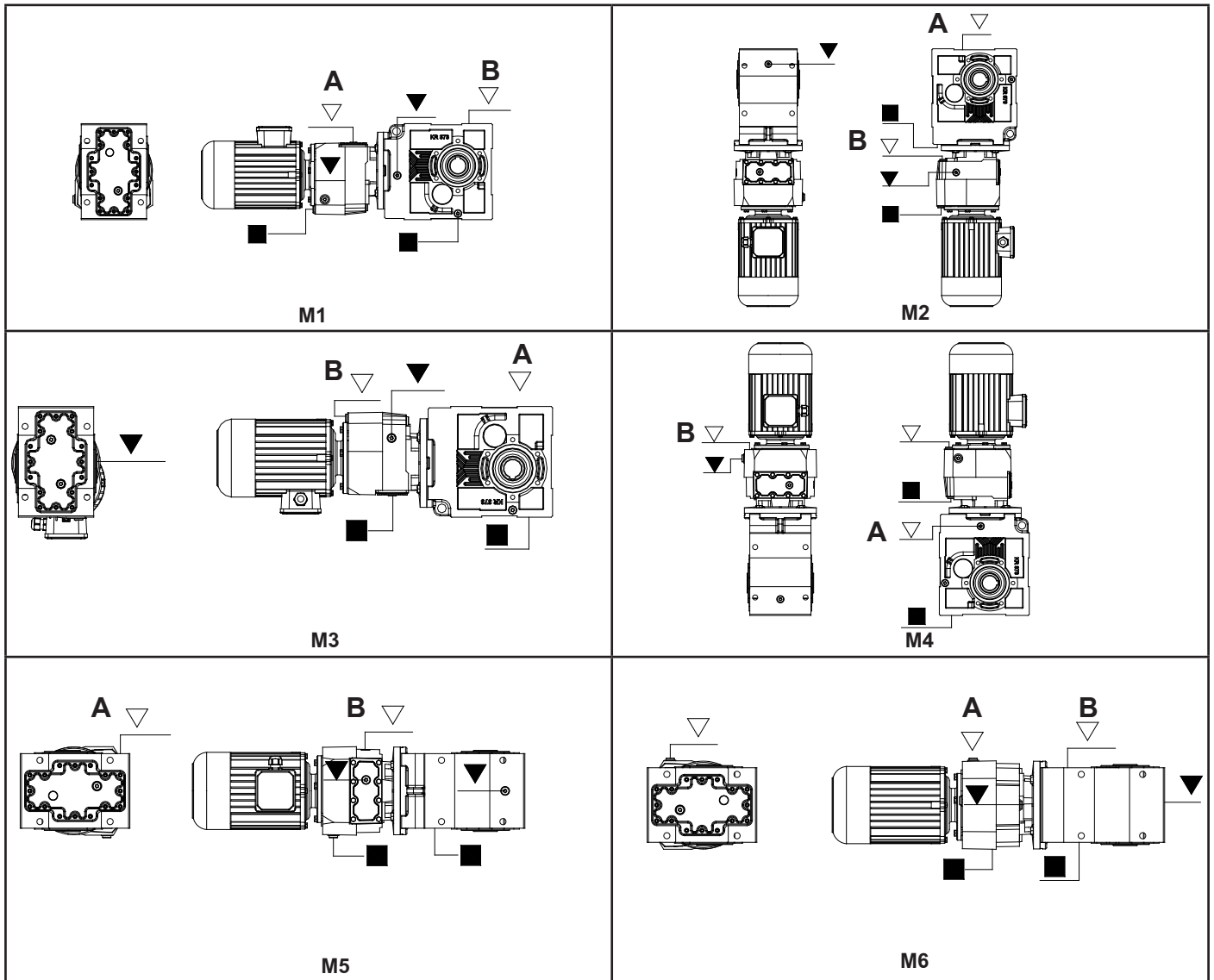

Oil Quantities. (liter)

Type	M1 A / B	M2 A / B	M3 A / B	M4 A / B	M5 A / B	M6 A / B
K.275-276	1,3 / 0,4	2,0 / 0,6	2,0 / 0,5	2,1 / 0,6	1,5 / 0,5	1,3 / 0,4
KR375-376	2,10 / 0,65	3,3 / 0,9	3,2 / 0,7	3,7 / 0,9	2,4 / 0,7	2,8 / 0,7
K.475-476	5,0 / 1,2	6,5 / 2,0	6,0 / 2,0	7,0 / 2,0	4,8 / 1,4	5,5 / 1,4
K.575-576	6,5 / 1,9	9,5 / 3,3	9,5 / 3,0	10,0 / 3,3	7,5 / 2,6	8,0 / 2,6
K.675-676	15,0 / 2,0	19,0 / 3,3	19,0 / 3,1	20,5 / 3,4	18,0 / 2,8	17,0 / 2,6
K.775-776	21,0 / 2,0	31,0 / 3,4	29,0 / 3,1	34,0 / 3,4	25,0 / 2,8	21,0 / 2,6
K.875-876	37,0 / 2,0	50,0 / 3,4	50,0 / 3,1	60,0 / 3,4	45,0 / 2,8	39,0 / 2,6

Symbols : ■ : Drain plug

▽ : Oil Filling and Vent plug

▼ : Oil level



## 9.4- Mounting Positions

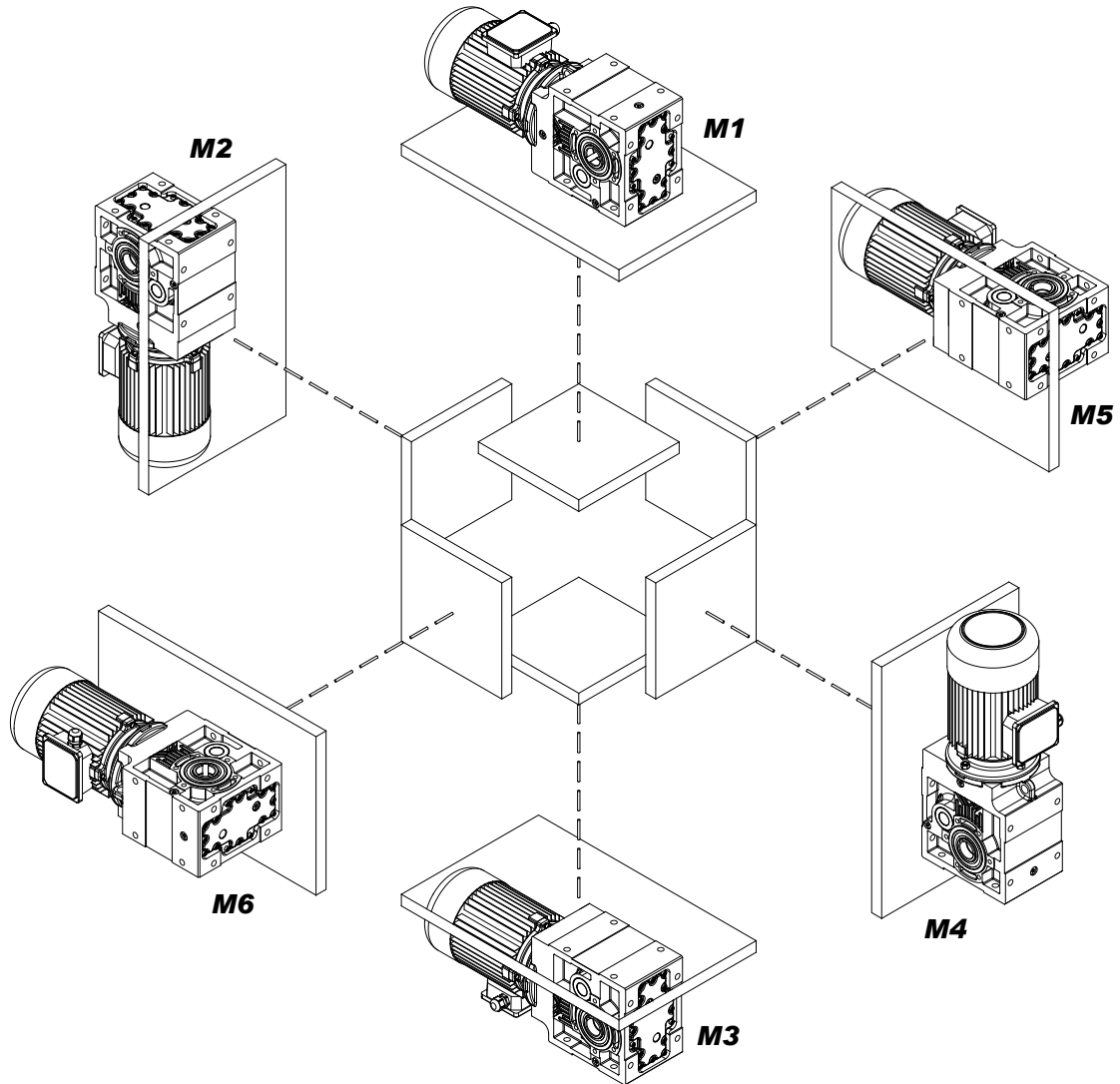

Figured mounting positions of M1 to M6 are determined as reference of directional position of the gearbox. Mounting surfaces are not binding.



## 10- Troubleshooting Guide



All the operations bellow must be done by authorized and skilled mechanician / electrician. Inform YILMAZ REDUKTOR before making any change to the gearbox. Only oil change is allowed to change without information. Do not make anything if you are not sure what you are doing and contact YILMAZ REDÜKTÖR. Any change or operation done without the information of YILMAZ REDUKTOR is in your own risk and responsibility and YILMAZ REDUKTOR does not take any responsibility.

ID	Problem	Observation	Remedy
001	Gearbox Does Not Start Up	You hear no noise and shaft is not turning. You are not using any driver or frequency inverter.	Please Check the voltage supply and frequency of your electric connection. They must be in accordance with the nameplate of the motor. Observe motor manufacturers start up manual. Still does not work go to ID 100
002	Gearbox Does Not Start Up	You hear no noise and shaft is not turning. You are using frequency inverter or driver.	Please observe the frequency inverter/driver manual. Check the motor by supplying direct voltage to see if the problem is on your driver/frequency inverter. Still does not work go to ID 001.
003	Gearbox Does Not Start Up	You hear some noise but both motor shaft and gearbox shaft is not turning. You are not using any driver /frequency inverter or braked motor.	Please Check the voltage supply and frequency of your electric connection. They must be in accordance with the nameplate of the motor. Observe motor manufacturers start up manual. Still same problem, the load may be too high for the chosen motor. Loosen the gearbox from the load/torque. If it works than the starting torque is insufficient and higher motor power is needed. For monophaze motors, check the starting up condensator and running condensator as well. If nothing helps go to ID 100
004	Gearbox Does Not Start Up	You hear some noise but both motor shaft and gearbox shaft is not turning. You are using driver or frequency inverter.	Please observe the frequency inverters or drivers manual. To see if the problem is on your driver or frequency inverter take out the driver/frequency inverter and make direct voltage supply to the motor according the motors nameplate. Still does not work go to ID 100
005	Gearbox Does Not Start Up	You hear some noise but both motor shaft and gearbox shaft is not turning. You are using braked motor	Please Check the voltage supply and frequency of your electric connection. They must be in accordance with the nameplate of the motor. Observe motor manufacturers start up manual. Be sure that the brake is working. Observe the brake manufacturers Manuel. If brake is supplied from YILMAZ REDÜKTÖR observe this Manuel for correct brake wiring diagram. If still not work supply the brake with voltage according its nameplate directly. For example 198V DC. You will hear a clicking noise explaining that the brake is opening. If you hear no noise the brake or rectifier is defect. If you hear the clicking noise the brake is working. You should this clicking noise by your normal electric connection as well. By supplying direct supply to the brake you hear the clicking noise and at same time you supply the motor with direct voltage according to its name plate and still same problem, the load may be too high for the chosen motor. Go to ID 003.

# Operating Instructions

## K Series

### Troubleshooting Guide



ID	Problem	Observation	Remedy
006	Gearbox Does Not Work in Low Speeds/ frequencies.	You are using frequency inverter.	For very low speeds the frequency inverters frequency is lowering down. For very low frequencies the inverter parameter and motor parameter must be optimise. Also for low speeds the efficiency of the gearbox may vary too much. Specially for worm-gearboxes. The recommended frequency range is 20-70 Hz for worm-gearboxes and 10-70 Hz for Helical Gear Boxes. Use Higher motor power and Frequency inverter or change ratio of gearbox to work inside the recommended range.
007	Gearbox Does Not Start Mornings or After Long Time Stop.	Ambient Temperature is below +5 Celsius	The oil is not in accordance with your working conditions. Change to lower viscosity oils. Observe this Manuel for using the correct oil. Working in higher ambient temperatures is an other solution if possible. If still same problem you need higher motor power.
008	Gearbox is Heating Up too Much	You are using Worm Gear Box and ambient temp is lower than +40 Celsius	Measure the surface temp. using a temperature measuring device under full load. If the temp is under +80 Celsius this will make no harm to the gearbox and is normal. All ATEX conforming gearboxes and standard worm gearboxes are designed to work under max. +120 Celsius. <u>If higher than +120 Celsius and using ATEX conforming gear box immediately stop the system and contact YILMAZ REDUKTOR.</u> Go to ID 100. If not ATEX confirming check the oil type and oil quantity/level according your mounting position and check the nameplate mounting position. If nameplate mounting position does not fit the actual position go to ID 100.
009	Gearbox is Heating Up too Much	You are using Helical Gear Box. Ambient temp is lower than +40 Celsius	Measure the surface temp. using a temperature measuring device under full load. If the temp is under +80 Celsius this will make no harm to the gearbox and is normal. All ATEX conforming gearboxes are designed to work under max. +120 Celsius. <u>If higher than +120 Celsius and using ATEX conforming gear box immediately stop the system and contact YILMAZ REDUKTOR.</u> If not ATEX gearbox the gearbox is designed to work under max. +80 Celsius. If higher than +80 Celsius check the oil type and oil quantity/level according your mounting position and check the nameplate mounting position. If nameplate mounting position does not fit the actual position go to ID 100
010	Gearbox is Heating Up too Much	Ambient Temp is over +40 Celsius	Standard Gearboxes are designed to work under +40 Celsius. ambient temperature. If ambient temp is higher than +40 Celsius special solutions/gearboxes are required. Please contact YILMAZ REDÜKTÖR
011	Gearbox is noisy	Nois is regular continuous	Check Your moving parts for noise. Disassemble the gearbox and run without load. If you still hear the noise motor bearings or gearbox bearings are defect. Change bearings. Go to ID 100
012	Gearbox is noisy	Nois is random	Check Your moving parts for noise. Disassemble the gearbox and run without load. If you hear still the noise the oil may has some particles inside. Change the oil and look for small particles. If metal particles are found the gearbox may have some damage. Go to ID 100

# Operating Instructions

## K Series

### Troubleshooting Guide



ID	Problem	Observation	Remedy
013	Gearbox is noisy	Regular knocking noise	Check Your moving parts for noise. Disassemble the gearbox and run without load. If you still hear the noise one of the gears inside is defect. Go to ID 100
014	Gearbox is noisy	Regular up and down noise	Check the output-shaft connection elements for run out. Take out the output shaft element and run without load. If you still hear the noise one of the gears has run out problem. Go to ID 100
015	Gearbox is noisy	Gearbox is with braked motor and noise is coming from the brake side randomly.	Low randomly clicking noise may come from the brake disk which is normal. If noise level is disturbing the brake may be defect or brake clearance is not adjusted. Go to ID 100
016	Gearbox is noisy	You are using frequency inverter and the noise level is changing according your speed.	The frequency inverter parameters are not optimised for the frequency range or motor you are using. Observe the frequency inverters manual. If still same problem change the ratio of gearbox. Go to ID 100
017	Oil is Leaking	Oil Leakage from Seal	If ambient Temp is over +40 Celsius or none stop work over 16 hours please change the top plug with a breather plug. Observe this manual for using breather plug. If this is not your case the seal could be damaged. Go to ID 100
018	Oil is Leaking	Oil Leakage from Plug	If you are using breather plug be sure it is in the correct place. This is the most top plug position according your mounting position. The plug may be not tight enough. There are some particles under the plug rubber surface. Clean and tighten the plug. If still same problem go to ID 100
019	Oil is Leaking	Oil Leakage from Housing	Observe exactly where the oil is coming out. It could be seal or plug point where it comes out and leaks over the housing. If this is your case go to ID 018/019. If you are sure oil comes out from housing than housing has some micro split / crack. Go to ID 100
020	Oil is Leaking	Oil Leakage from Cover	The sealing liquid under cover is split/defect. Disassemble the cover and put new sealing liquid. Assemble the cover and tighten the bolts. If still same problem go to ID 100
021	Gearbox is moving regularly on its mounting point	You are using Torque Arm	The movement of gear box is because of the run out of the shaft which you assemble the gearbox. This has no bad affect or harm to the gearbox and is normal unless you are using torque arm.
022	Gearbox is moving randomly on its mounting point	You are using Torque Arm	The movement of gear box is because of the run out and clearance of the shaft which you assemble the gearbox. Check the clearance of the assembling shaft and the clearances on your machine. This has no bad affect or harm to the gearbox unless you are using torque arm.
023	Motor is heating up	Motor is running over its nominal current	The motor power is not enough or some overload to the motor is possible. The motor may be defect. Go to ID 100
023	Motor is heating up	Ambient is dusty	Check the motor Fan Hub and ribs. They must be free of dust. If you are using forced external fan, check if it is working. If you are using frequency inverter in low speeds and you do not have forced external fan, you may need forced external fan. Go to ID 100



ID	Problem	Observation	Remedy
024	Motor is running but Gear-box shaft does not turn	Scratching noise comes out	Some part (key, gear) may be defect inside gearbox. Go to ID 10
025	Gearbox Housing is Defect	You are using chain drive or pinion gear	The radial load or polygon effect of the chain may have caused the damage. Check also if the assembly bolts are loosened or the plate you assemble the gearbox is rigid enough. Check if you are using the correct diameter of chain drive and you are not exceeding max. Allowed radial load. Check the position of your output element and re-calculate your radial load and check if this fit to the maximum allowed radial load. Go to ID 100
026	Output Shaft is Defect	You are using chain drive or pinion gear	The radial load or polygon effect of the chain may have caused the damage. Check also if the assembly bolts are loosened or the plate you assemble the gearbox is rigid enough. Check if you are using the correct diameter of chain drive and you are not exceeding max. allowed radial load. Check the position of your output element and re-calculate your radial load and check if this fit to the maximum allowed radial load. Go to ID 100
027	Gearbox is stopping too late	You are using braked motor	Please check the wiring diagram of the brake. There are two different kind of brake wiring diagram. The standard gearbox delivered from our factory is set to delayed braking. For sudden braking check the wiring diagram.
028	Gearbox is starting too late	You are using braked motor	For fast opening of big brakes (over 100 Nm), you may need shock transformers which is supplied by YILMAZ REDÜKTÖR. Go to ID 100
100	Service Required	No self solution found	Please contact YILMAZ REDUKTOR Service point. See on the back side of this manual. Changing mechanical parts of gearbox can only be done by YILMAZ REDUKTOR or with information of YILMAZ REDUKTOR. Any change without informing YILMAZ REDUKTOR will cancel the warranty, manufacturer declarations and YILMAZ REDUKTOR will take no responsibility.

## 11- Disposal

If your product is no longer of use and you wish to dispose of it, refer to the instructions here. If you have any questions regarding ecological disposal methods, please consult our service points given on the backside of this Manuel.

### 11.1- Disposal of Oil

Lubricants (oil and greases) are hazardous substances, which can contaminate soil and water. Collect drained lubricant into suitable receptacles and dispose of it according to the valid national guidelines.

### 11.2- Disposal of Sealings

Remove the sealing rings from the gear reducer, and clean them of oil and grease residues. Dispose of the sealings as composite material (metal/plastic)

### 11.3- Disposal of Metal

Divide up the remainder of the gear reducer into iron, aluminium, non-ferrous heavy metal if possible. Dispose of it according to the valid national guidelines.

# Appendix



## Warranty Conditions:

1. The geared motors and gear units are warranted for two year except the electric motor. For motor warranty please refer to the manual of the electric motor manufacturer or the warranty document of the motor manufacturer. This warranty is valid only if the gearbox is assembled and started up according our operating instructions and is used under the allowed conditions for the appropriate gearbox type in our catalogue. Special Gearbox parts made according customer request are not covered by this warranty.
2. The warranty time starts from the start up time written on the warranty document and last for two years. If the start-up time is more then three months after the billing time, the total warranty time is limited to 27 months starting from billing time. If the warranty document is not send to our company after start-up, the total warranty time will be limited to 24 months after the billing time.
3. Any time during the warranty for maintenance, repair or change will be added to the warranty time. This time starts from the date which the company or representative was made aware of the problem and ends on the date of the re-start-up.
4. If the product fails to operate because of a manufacturing or assembly failure during the warranty time, the product will be repaired free of charge.
5. If the product fails to operate because of a manufacturing or assembly failure during the warranty time and it is not possible to repair it, the product will be changed with a new one according to the report from our service department mentioning that the hazard can not be repaired.
6. Costumers must inform the manufacturer if there are some problems after the service and repair of the failed product.
7. The extra costs like stopped plant, physical or mental injuries etc. by the costumer side are not covered by this warranty except the product itself.

### **YILMAZ REDUKTOR San. ve Tic. A.S.**

**Head Office:** Maltepe Gumussuyu Cad. Bestekar Medeni Aziz Efendi Sok. No:54  
P.K.34020 Topkapi/Istanbul-TURKEY

Phone: +90 (0) 212 567 93 82/83 , Fax: +90 (0) 212 567 99 75

### **Factory : YILMAZ REDUKTOR Sanayi ve Ticaret A.S.**

ATATÜRK Mah. Lozan Cad. No:17 P.K.34522 Esenyurt-İstanbul- TURKİYE

Telefon: +90 (0) 212 886 90 01 (8 line) , Fax: +90 (0) 212 886 54 57





## **Warranty Declaration and Instruction Manual Receipt Form**

YILMAZ REDUKTOR products are **warranted for 2 (Two) years** covering all parts and materials used in products and their production errors unless they are started-up and used according our service manual and is not modified or disassembled without an acknowledgement from our company.

The warranty covers all costs like repair, service, spare parts etc. and no charge will be asked under any name. The time for repair, service will be added to the warranty time.

For detailed warranty conditions please refer the back side of this page.

**Serial No:**

**Type:**

**Manufacturer:**

Company : YILMAZ REDUKTOR Sanayi ve Ticaret A.S.

Address : ATATÜRK Mah. Lozan Cad. No:17 P.K.34522 Esenyurt-İstanbul- TÜRKİYE

Telefon : +90 (0) 212 886 90 01 (8 line)

Fax : +90 (0) 212 886 54 57

**Stamp and Signature**

**Supplier / End User:**

With signing this part and sending this back to our company your warranty period will be started and you are accepting that you have received the operating instruction of the product.

Name:

Billing Date/ Bill No.:

Start-Up Place / Date:

Address:

Phone - Fax:

**Supplier/ End User Stamp and Signature**

## Service Contact Points:

### **Main Service Point:**

#### **YILMAZ REDUKTOR A.S.**

ATATÜRK Mah. Lozan Cad. No:17 P.K.34522 Esenyurt-İstanbul- TURKİYE

Telefon: +90 (0) 212 886 90 01 - 6hat , Fax: +90 (0) 212 886 54 57

### **Head Office:**

Tel: +90 (0)212 567 93 82 (2 line),

+90(0) 212 567 06 03,

+90(0) 212 567 40 78

+90(0) 212 567 04 11

+90(0) 212 567 45 07

+90(0) 212 567 00 70

Fax: +90(0) 212 567 99 75

e-mail: [yilmaz@yr.com.tr](mailto:yilmaz@yr.com.tr)

web: [www.yr.com.tr](http://www.yr.com.tr)

### **Factory:**

Tel: +90(0) 212 886 90 01 (8 line)

+90(0) 212 886 50 43

+90(0) 212 886 50 44

+90(0) 212 886 52 82

Fax: +90 (0) 212 886 54 57

e-mail: [yilmaz@yr.com.tr](mailto:yilmaz@yr.com.tr)

web: [www.yr.com.tr](http://www.yr.com.tr)

### **Outside Turkey:**

Please contact the main service point mentioned above. You will be directed to our nearest service point to your location