

Instruction Manual

(Digital Differential Pressure Transmitter)

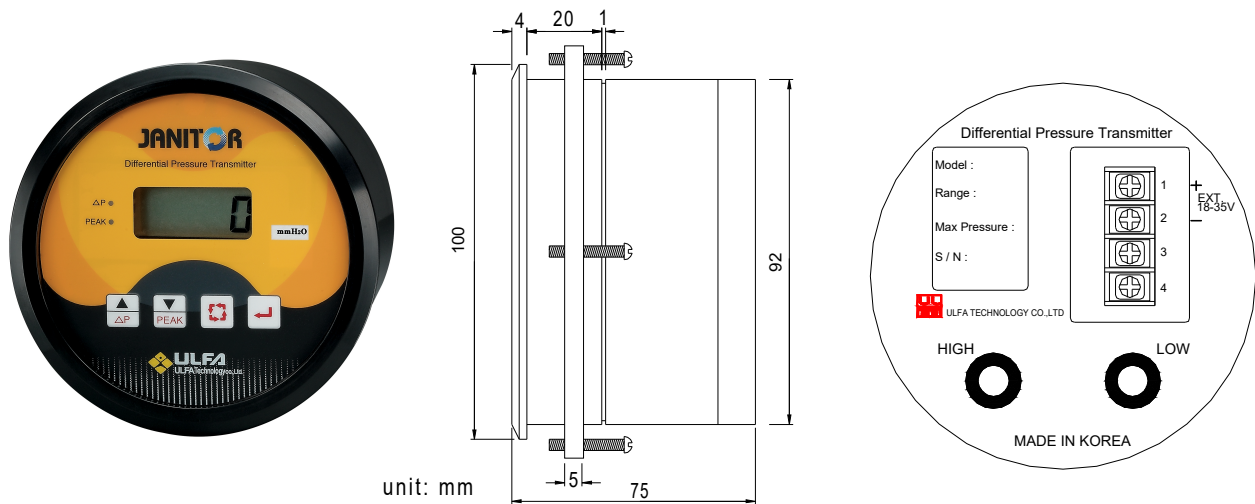

1. General Specification
2. Installation
3. Wiring
4. Function
5. Setting & Calibration



General

PDT Series pressure transmitter are measures and controls positive, negative(vacuum) and differential pressure of air or non corrosive gases, and for the variously choice of ranges available to suit your needs precisely.

The PDT Widely used to measure fan and blower pressures, filter resistance, pressure drop across orifice plates, liquid levels in storage tanks and many other applications. The PDT model has four functions of gauge, peak pressure detection, Offset(Δp) pressure and transmitter. It is very easy to set and use by front pad key.

Accuracy is $\pm 0.25\%$ of full scale.

Range Table

Model No	Range	Resolution
-B15M	± 15.0 mmH ₂ O	0.1 mmH ₂ O
-B150M	± 150.0 mmH ₂ O	0.1 mmH ₂ O
-B1500M	± 1500 mmH ₂ O	1 mmH ₂ O
-B760H	± 760 mmHg	1 mmHg
-D30M	0~30.0 mmH ₂ O	0.1 mmH ₂ O
-D300M	0~300.0 mmH ₂ O	0.1 mmH ₂ O
-D3000M	0~3000 mmH ₂ O	1 mmH ₂ O
-B01K	± 1.000 kg/cm ²	0.001 kg/cm ²
-B07K	± 7.00 kg/cm ²	0.01 kg/cm ²

We can apply to other user specification (Pressure units and range)

Specification

GENERAL

Maximum Pressure:
Media Compatibility:
Pressure Range:

Rated Range x 3
Air and non corrosive gas
Refer to range table

ELECTRICAL

Power Supply:

DC24V(100-220VAC
50~60Hz)

Connections:

2 screw terminal block

Display:

4 Digit LCD

Warm up Time:

15 minutes

TRANSMITTER

Connections:

2 Screw terminal block

Output Signal:

4-20mADC(limited at
30mADC)

Loop Resistance:

0 - 1100 Ω

Zero & Span Adj:

One touch Adjustable on
Panel

PERFORMANCE AT 23 °C

Zero Output:

4 mA

Full Span Output:

20 mA

Accuracy:

$\pm 0.25\%$ FSO(Includes
Linearity, Hysteresis &
Repeatability)

Operating Temperature:

-10 to 70°C

MECHANICAL

Pressure Connections:

1/8" PT female

Materials:

ABS Mold Resin

Weight

600g

STANDARD ACCESSORIES

Tow(2) 1/8" PT plugs for duplicate/ Snap ring
Mounting ring, four(4) mounting screws

Installation

LOCATION : Select your site location , Clean and dry, no shock and vibration, proper to the ambient temperature and humidity in use.

PANEL MOUNTING

The PDT Series Digital Pressure Transmitter is designed for panel mounting in a single 93mm diameter hole.

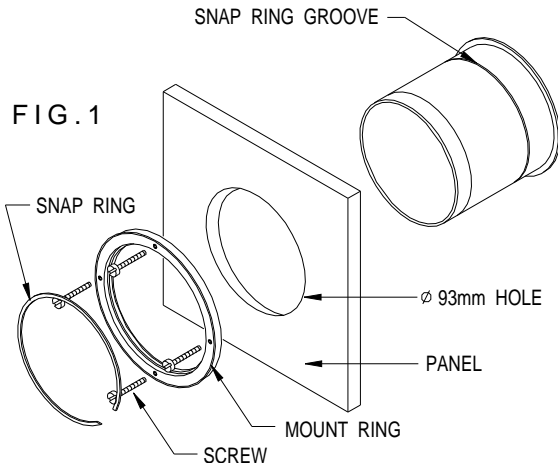

A panel mounting fastening kit is provided with all PDT Series Pressure Transmitter.

1. Select your site location, mark the appropriate panel cutout and complete the necessary panel cut.
2. Carefully insert the Pressure Transmitter through the hole from front of the panel.
3. Carefully insert the mount ring through the body of PDT from back side.
4. Insert the snap ring to the snap ring groove.
5. Tightening four mount screw through the mount ring from back side.

PRESSURE PORT CONNECTION

Tow(2) PT 1/8" barbed nipples are provided with all PDT Series Pressure Transmitter

1. Wind teflon seal tape 3 or 4 times on the screw of the nipple and tightening it in the pressure port high and low
2. If you use the PDT to measure differential pressure, high pressure is connect to "HIGH" port, and low pressure is connect to "LOW" port.
3. If you use PDT to measure single pressure, positive pressure is connect to "HIGH" port and negative pressure(vacuum) is connect to "LOW" port. (In this case, another port is open to air)
4. Standard pressure connections are barbed fittings for 3/16" I.D. tubing.

Wiring

POWER CONNECTION

The following procedures are to be used to install a standard 24V DC main power source.

1. Before connection, the user must first confirm that the power specification is DC24V or AC100-220V.
2. Verify that the facility's main power source is turned off or disconnected.
3. Connect lead cable to power terminal matching polarity as shown in FIG.2 below. Take care that wrong wiring will damage the Instrument and malfunction (AC220V is not concerned to polarity)

CURRENT OUT CONNECTION(4-20mA)

The PDT sends a standard 2wire 4-20mA current out

1. Connect lead cable to current out terminal matching polarity as shown in FIG.2 below.
2. Do not run the signal cable along with any high voltage or power cable or put them in the same race way. It may cause malfunction due to induction.

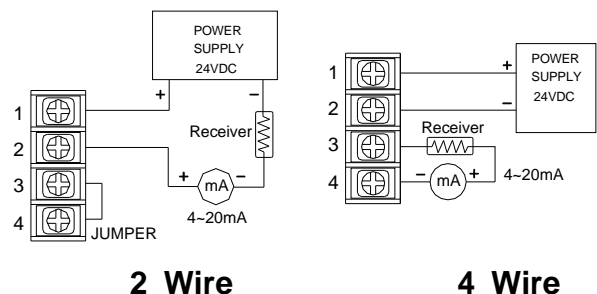
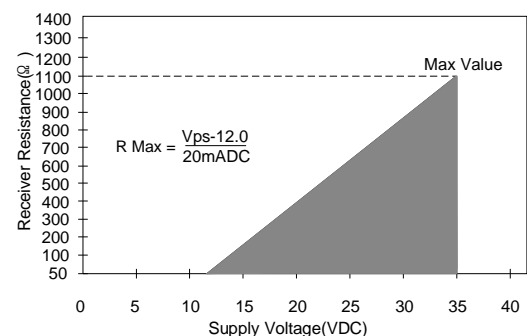

FIG. 2

The ranges of optimum receiver resistance is refer to below graph.



Function

Zero setting : Optimize display and current out to zero automatically by front key pressed.

Peak pressure Measurement : This mode is display for peak pressure by supplied pressure. And the display is cleared by press enter key in the peak mode.

Offset(p) pressure Measurement : This mode is display the changed pressure based on the current pressure. Current pressure is turned into "0" when offset mode selected. This mode does not concern to 4-20mA current out put.

Sampling time setting : Sample rate is 0.1sec of this product. Sampling time is measuring time by sample rate. For example, if setting time is 2 sec, PDT measures 20 times for 2 seconds and out to display and 4-20mA out put by average of 20 times measured value.

Transmitter : PDT has 4-20mA current out put. Span (20mA) range can be changed within original range.

Communication(option) : Measurement pressure can be sent by RS232 or RS485 for option specification.

ID setting : This mode set identification number for communication.

Over pressure warning : PDT displays warning on LCD for over pressure (positive and negative). Upper 4 elements of segment("— — — —") blink for warning when measurement pressure over 10% for high pressure(factory setting value), And under 4 elements of segment("_ _ _ _") blink for warning when measurement pressure under 10% for low pressure(factory setting value),

Factory setting recovery : The parameters are changed all to factory setting value and all user setting value is cleared.

Setting and Calibration

Hear by describe key function and setting methode. Please read this section carefully for the correct and optimum use of this product.

Key functions

	UP	- Increase setting value - Offset mode set/reset
	DOWN	- Decrease setting value - Peak pressure mode set/reset
	MODE	- Entering into the setting mode - Setting item circulation
	ENTER	- Save setting value - Clear peak value in the peak mode - Release setting mode

Peak mode

Press the PEAK(down) key once to set peak mode

Press the ENTER to reset peak value and newly start

Press the PEAK(down) key once more to release peak mode

Offset mode

Press the P(UP) key once to set offset mode

Press the P(UP) key once more to release offset mode

User setting mode

Entering User setting mode : Press MODE key for more than 3seconds till appear "I n t" on LCD into the user setting mode. Press the MODE key once in user setting mode to change setting item. The setting item circulate " I n t " " PoFS " " P 4 " " P20 " " Id " " FACT " " I n t " while mode key press repeated. Each item setting methode is refer to next pages.

Save : If you complete your setting in the each mode, Press ENTER once to save and exit to measure mode. Press ENTER for more than 3 seconds to save and exist in the setting mode.

Release User setting mode : Press ENTER once to save and exit to measure mode. If you are not operate this instrument for about 1 minute, It's released user setting mode automatically and return to measuring mode.

Sampling time setting

It can be set 0.1~5.0 seconds by 0.1 sec resolution. PDT reading pressure 0.1sec interval for a setting time and calculate average pressure to display and 4-20mA output.

(ex) setting time : 2 sec
 PDT reading pressure 20 times for 2 seconds and calculate average of measured 20 data to display and 4-20mA current output.
 This functions is useful to measure hunted pressure

Press MODE key for more than 3 seconds till appear "Int" on LCD display like left.

Release MODE key then appear current set time on LCD display (default set time is 0.5 sec)

Set your sampling time use up/down key

Press ENTER once to save and exit to measure mode.

Press ENTER key for more than 3 seconds till appear "SAvE" on display to save and exist in the sampling time setting mode

Zero setting

Optimize zero to display and current out automatically by front key pressed.

CAUTION : Release pressure port free before zero set

Press MODE for more than 3 seconds till appear "Int" on LCD display

Press MODE key once till appear "PoFS" on LCD display.

Press ENTER once to set zero and exit to measure mode. "PoFS" blink for about 5 seconds to calculate zero.

Press ENTER key for more than 5 seconds till appear "SAvE" on LCD display to save and exist in the setting mode.

4mA current setting

This function is set pressure level to 4mA current out. Generally pressure zero is setting to 4mA current out. By the way, negative pressure is setting in another case. PDT can be set any pressure level to 4mA current out between low and high pressure range. Low and high pressure ranges are setting in factory.

Press MODE key for more than 3 seconds till appear "Int" on LCD display.

Press MODE key once till appear "P4" on LCD display.

Set your pressure level to 4mA out use up/down key

Press ENTER once to save and exit to measure mode.

Press ENTER key for more than 3 seconds till appear "SAvE" on LCD display to save and exist in the setting mode

20mA current setting

This function is set pressure level to 20mA current out, That is set span. PDT can be set any pressure level to 20mA current out between low and high pressure ranges.

Low and high pressure ranges are setting in factory.

Press MODE key for more than 3 seconds till appear "Int" on LCD display.

Press MODE key once till appear "P20" on LCD display.

Set your pressure level to 20mA current out use up/down key

Press ENTER once to save and exit to measure mode.

Press ENTER key for more than 3 seconds till appear "SAvE" on LCD to save and exist in the setting mode

Recall to Factory setting value

This function is recall to initial states of factory out from unmatched user parameters that zero, span etc.

Press MODE key for more than 3 seconds till appear "Int" on LCD display.

Press MODE key once till appear "FAcT" on LCD display.

Press ENTER once to recall and exit to measure mode.

Press ENTER key for more than 3 seconds till appear "SAvE" on LCD to recall and exist in the setting mode

ID No setting

ID number is use for address for communication to master. It's concern to PDT communication function installed.(option)

Press MODE key for more than 3 seconds till appear "Int" on LCD display.

Press MODE key once till appear "ID" on segment.

Set your ID No use up/down key(0~255) default set is 0.

Press ENTER once to save and exit to measure mode.

Press ENTER key for more than 3 seconds till appear "SAvE" on LCD to save and exist in the setting mode.

ULFA TECHNOLOGY CO.,LTD
 344, industrial zone ,201 haan 3-dong
 kwang myung-city, kyung ki-do
 423-754 KOREA
 TEL:02-806-4403 FAX:02-806-4406
 ulfatech@ulfatech.com