

Ultraflex Cleanroom UCR All Types Clean Work Cabin

Technical Concept



Product Description

The UCR is a free standing fully functional cleanroom. The UCR can operate with laminar or turbulent air-flow and meets the requirements for cleanroom classes 3.0 to 8.0 according to DIN EN ISO 14644-1 or M 1.5 (1) to M 6.5 (100 000) according to US Federal Standard 209E.

The UCR system can be installed as an open or closed system, and available wall materials include simple PVC strip curtains or partition walls made of aluminum, steel, stainless steel, Macrolon or glass. Coated floors and raised floors made of aluminum or steel are also part of the system.

There are various possibilities to combine the different components.

Complete solutions with integrated make-up air, exhaust air, self-contained cooling and controls are also available.

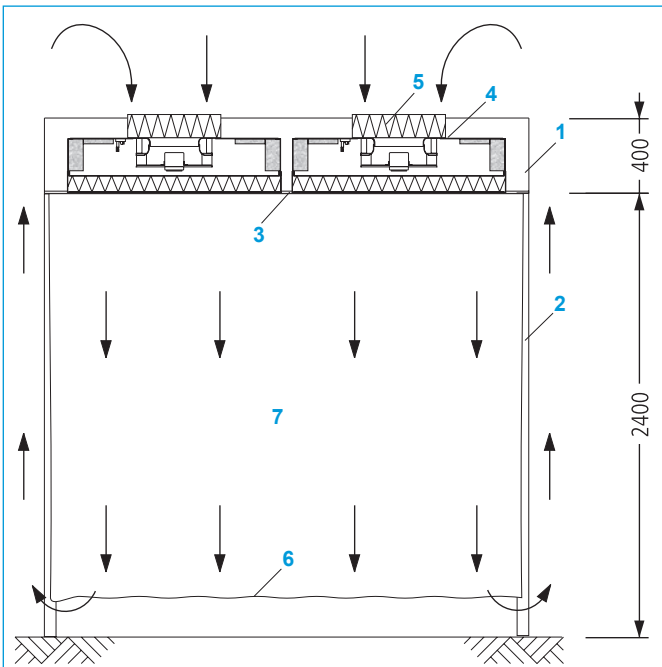

Fig. 1 Open system, example

System Construction and Function

Self-supporting module sheet metal **1** provides the basic UCR construction, combined with stainless steel members with a standard height of 400 mm, connected to aluminium, steel or stainless steel pedestals **2**. Either Ultraflex Ceiling Grid (types UFR-55/70-T/E and UFR-55/70-T/P) or Ultraflex Cassette Ceiling which is made according to EU-GMP or FDA can be used for the cleanroom ceiling **3**. Filter Fan Units **4** (FFUs), provided with AC motors or electronically commutated DC motors, supply the cleanroom with clean air (optional prefilter **5**). The UCR system comes standard with PVC curtains **6**.

The FFUs draw room air in and blow it through a HEPA filter into the working area **7**, which is cleaned with a vertical, low turbulent air-flow. The contamination in the working area is pushed out to the bottom. In open systems (Fig. 1) the air simply flows out into the surrounding room. In closed systems (Fig. 2) the air returns through the return air chases **8** and the plenum **9** to the FFUs. To achieve this flowpath the UCR is installed with walls **10** and plenum covers **11**. Prefilters can be integrated in the return air chases of the ceiling system if required.

The length and width of the UCR can be determined based on the space requirements. Depending on the load of ceiling components a span of up to 4800 mm can be built without any intermediate columns or hangers. The clear height of the UCR can be from 2000 mm to 3000 mm.

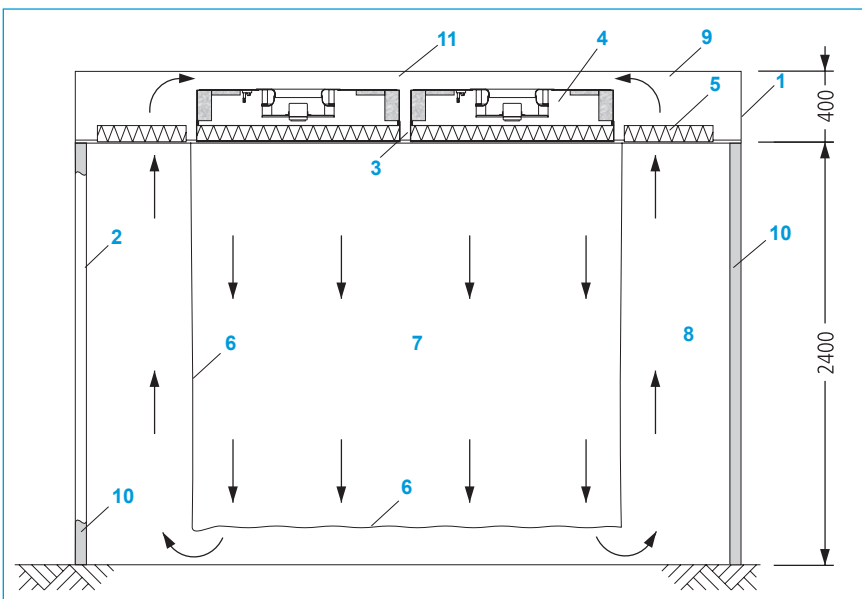

Fig. 2 Closed system, example

Legend

- | | |
|----------------------------------|-----------------------------|
| 1 Module sheet metal | 6 PVC curtain |
| 2 Pedestal | 7 Clean working area |
| 3 Cleanroom ceiling | 8 Return air chase |
| 4 Filter Fan Unit COMPACT | 9 Plenum |
| 5 Prefilter | 10 Wall system |
| | 11 Plenum cover |

Available Designs

- Partition wall systems made of steel, stainless steel or aluminum
- PVC panel curtains and PVC strip curtains
- Glass or Macrolon glazing
- Aluminum or stainless steel doors
- Adjustable height pedestals either floor-mounted or on casters
- Either surface mounted or recessed light fixtures
- Filter Fan Unit COMPACT with single phase AC motor or electronically commutated EC motor, both have external rotor motors with stepless adjustment
- Prefilter and/or cooling coil (standard sensible capacity 2 kW) for Filter Fan Units
- Air-flow adjustment via plug & play cabling with manual speed controller or programmable LON bus control
- HEPA filter classes H13 to U17

Key Features

- Stable, aesthetically pleasing, inexpensive system
- Short lead time and quick installation without customization
- Easy dismantling and relocation
- Low plenum height is advantageous for installation in existing buildings
- Very suitable for unique solutions
- Can be used as a laminar flow or turbulent air system
- Designed according to GMP- or FDA-guidelines, available for pharmaceutical industry, biotechnology or food industry

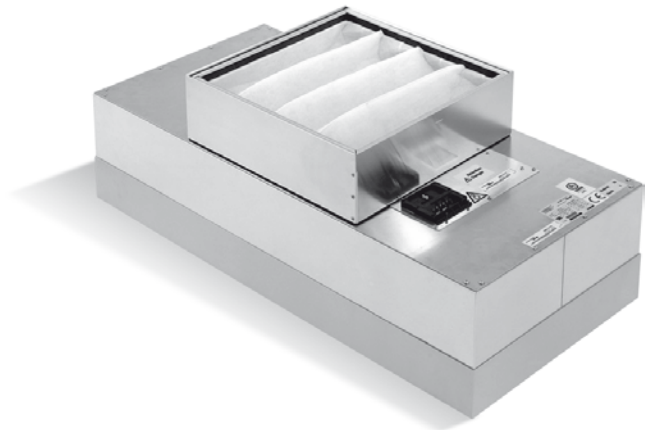

Fig. 3 Filter Fan Unit COMPACT with prefilter 5



Fig. 4 Filter Fan Unit COMPACT with cooling coil and refilter 5

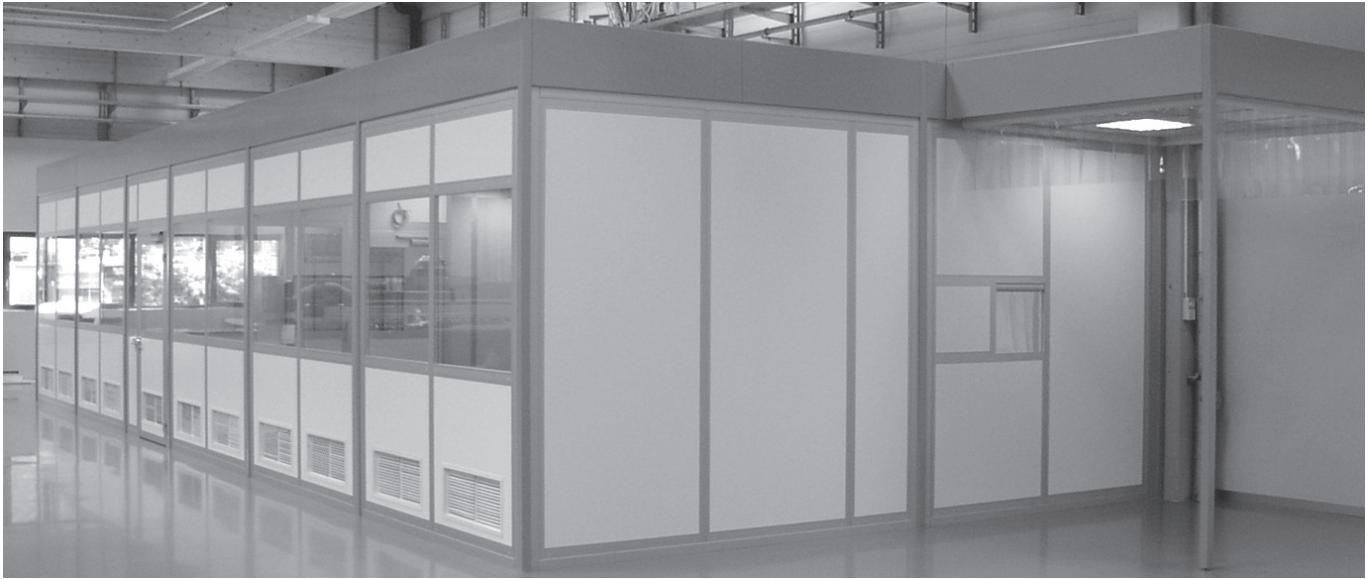
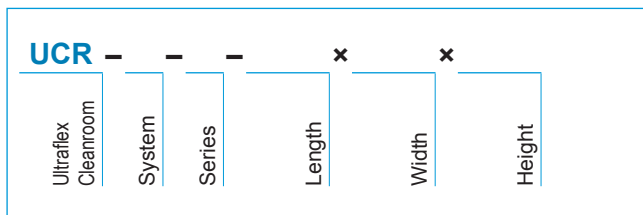

Fig. 5 Open system with double skin aluminum panel walls; special size: length 16740 mm x width 5580 mm, clear height 2800 mm; integrated entry with PVC strip curtains

Type Designation



System

- 0 open system mobile (on casters)
- 1 open system suspended
- 2 open system floor mounted
- 3 open system floor mounted with raised floor
- 4 closed system floor mounted with raised floor
- 5 closed system floor mounted without raised floor

Series

- 1 Electronics (ceiling grid UFR-55/70-T/E)
- 2 Pharmaceutical industry (ceiling grid UFR-55/70-T/P)
- 3 Pharmaceutical industry (cassette ceiling UKD)
- 4 Special design

Module Dimensions

Length x Width
1200 x 1800 / 2400 / 3000 / 3600 / 4800 (mm)
2400 x 1800 / 2400 / 3000 / 3600 / 4800 (mm)
3600 x 1800 / 2400 / 3000 / 3600 / 4800 (mm)
4800 x 1800 / 2400 / 3000 / 3600 (mm)

Height

- 2400 mm – overall height, clear height 2000 mm
- 2800 mm – overall height, clear height 2400 mm (Standard)

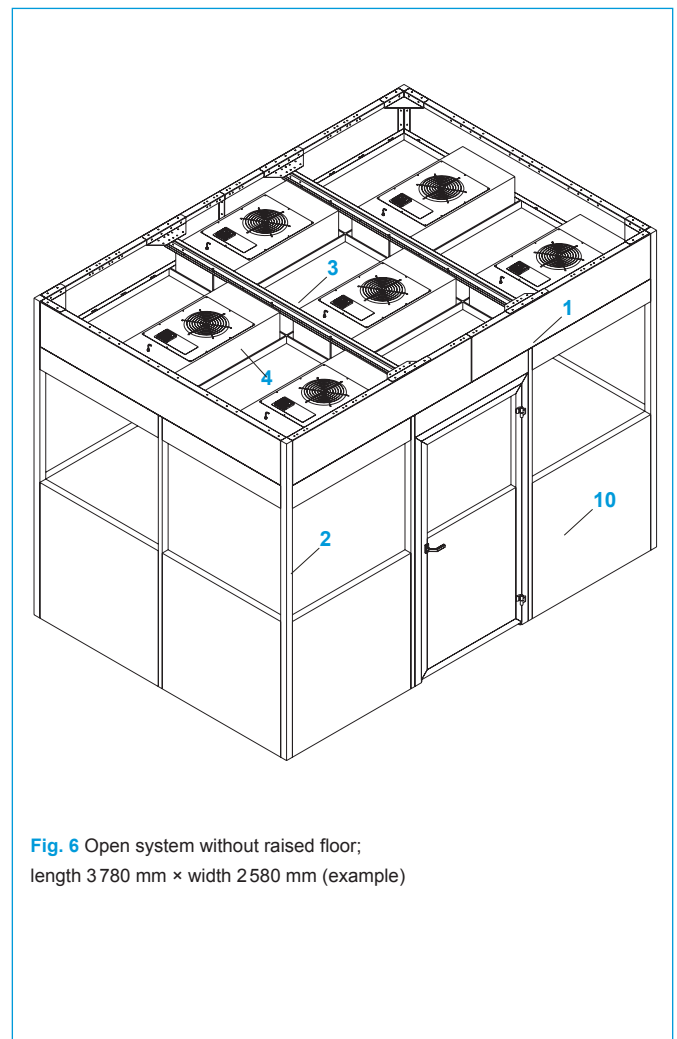

Fig. 6 Open system without raised floor; length 3780 mm x width 2580 mm (example)

Submittal Text

The UCR system is suitable for cleanroom classes up to 3.0 according to DIN EN ISO 14644-1.

Self-supporting sheet metal provides the basic UCR construction of the plenum, combined with aluminum, stainless steel members with a standard height of 400 mm, connected to aluminium, steel or stainless steel pedestals for floor mounting, or suspended from the room ceiling.

Either Ultraflex Ceiling Grid (types UFR-55/70-T/E and UFR-55/70-T/P) or Ultraflex Cassette Ceiling which is made according to EU-GMP or FDA can be used for the cleanroom ceiling. Filter Fan Units (FFUs), provided with AC motors or electronically commutated DC motors, supply the cleanroom with clean air (prefilter optional). The UCR system is provided with standard PVC curtains.

The FFUs draw room air in and blow it through a HEPA filter into the working area, which is washed with a vertical, low turbulent air-flow. The contamination in the working area is pushed out to the bottom.

Open Systems

The air is flowing below the working area perimeter-curtains into the surrounding room and is absorbed again by the FFUs.

Closed System

The UCR system is designed with partition walls and closed ceiling grid plenum. The return air is circulating through the return air chases back to the plenum and is absorbed again by the FFUs. Alternatively, the return air flow for cleanroom classes ISO 7.0 and 8.0 can take place through perforated ceiling blanks.

Prefilters can be integrated in the return air chases of the ceiling system if required.

The length and width of the UCR can be determined based on the space requirements. Depending on the load of ceiling components a span of up to 4800 mm can be built without any intermediate columns or hangers.

Note

Additional submittal text and installation concepts can be found in the technical descriptions of the single components.

Cleanroom Class

- 10,000 FFU coverage $\geq 15\%$, filter class H14
- 1,000 FFU coverage $\geq 25\%$, filter class H14
- 100 FFU coverage $\geq 50\%$, filter class H14
- 10 FFU coverage $\geq 75\%$, filter class U15
- 1 FFU coverage $\geq 100\%$, filter class U15

Cleanroom Ceiling System

- Ceiling grid UFR-55/70-T/E (electronics)
- Ceiling grid UFR-55/70-T/P (pharmaceutical industry)
- Line ceiling grid UFR-55/70L-T
- Cassette ceiling UKD (pharmaceutical industry)

Filter Fan Unit COMPACT

- For FFU COMPACT AC with single-phase external rotor motor, air volume adjustable through → Control System AC
- For FFU COMPACT EC with electronically commutated, external rotor motor, volume flow adjustable through → Control System DC

Lighting

- Recessed luminaires
- Teardrop luminaires
- Track-mounted batten luminaires
- Pharmaceutical track-mounted batten luminaires

Pedestals

- Aluminium anodized
- Powder-coated steel similar to RAL 9010
- Brushed stainless steel

Wall design

- PVC panel curtain
- PVC strip curtain
- Double skin stainless steel panels, brushed
- Double skin aluminium panels, anodized or coated similar to RAL 9010
- Double skin steel sheet, powder-coated similar to RAL 9010
- Alucobond, 4 mm
- Macrolon glazing, clear
- Glass panes, clear

Manufacturer
Type

Exyte Technology GmbH

UCR-__-__-__x__x__

Local Support Wherever You Need Us

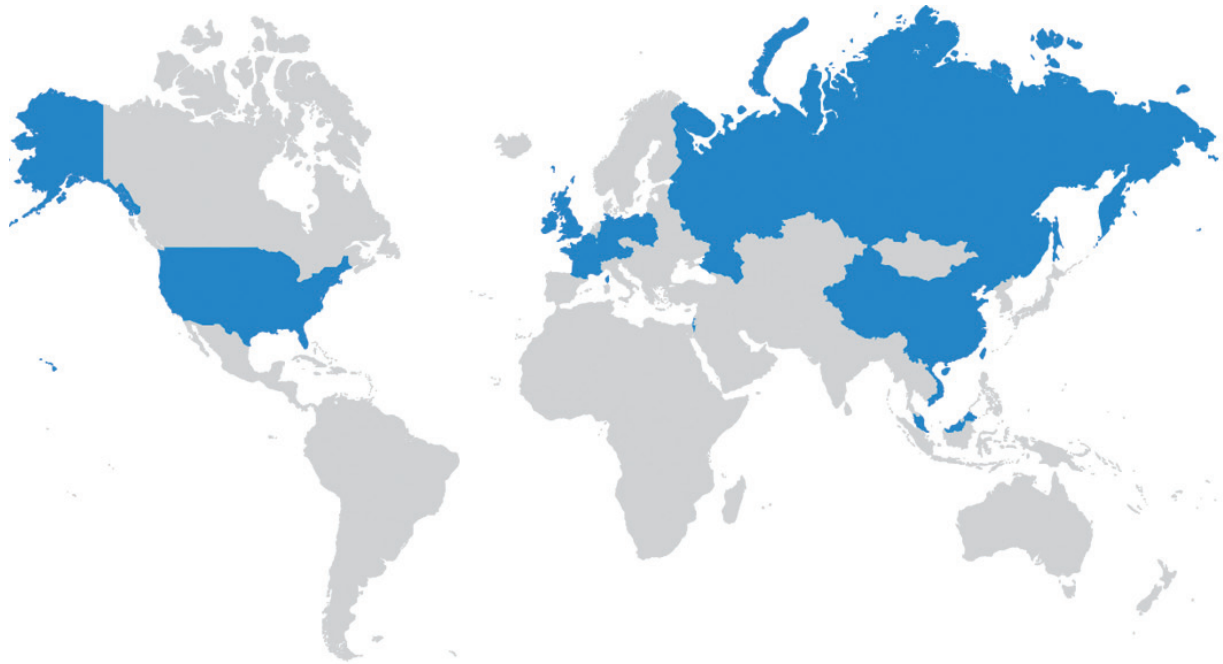

Exyte Technology GmbH
Rosine-Starz-Str. 2-4
71272 Renningen
Germany
Phone +49 711 8804-8000
Email info@exyte-technology.net

Exyte Technology Shanghai Co., Ltd.
No. 139 Beimin Road,
Chedun, Songjiang
201611 Shanghai, China
Phone + 86 21 37838360
Email info@exyte-technology.net