

D-4080 Retractable Writing Shelf

RETRACTABLE WRITING SHELVES

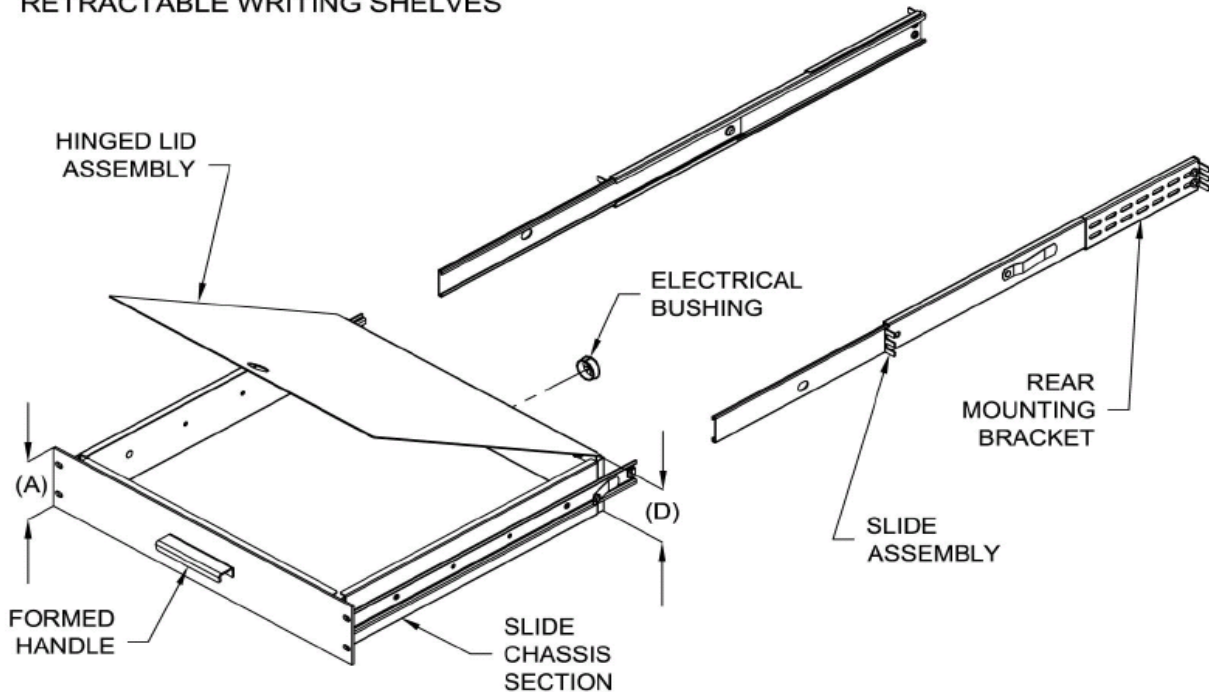

Slide assemblies with rear mounting brackets and assembly hardware as follows:

- TYPE **D-4080-1** uses TYPE C-300-S-420-RC-3S slide assembly and TYPE B-389 rear bracket
- TYPE **D-4080-3 & D-4080-5** use TYPE C-300-S-120 slide assembly and TYPE B-308 rear bracket

Retractable Writing Shelves

- Shelf is designed to mount in 19" EIA electronic rack.
- Drawer has 17" width and depth.
- 12 gauge front panel with formed push-pull handle.
- Hole in rear of the drawer to accommodate electrical cord and bushing.
- Retractable writing surface has black powder coat finish.

Part Number	Panel Height (A)	Drawer Height (D)
D-4080-1	1.72	1.42
D-4080-3	3.47	3.17
D-4080-5	5.22	4.92