

OUTPUT TORQUE

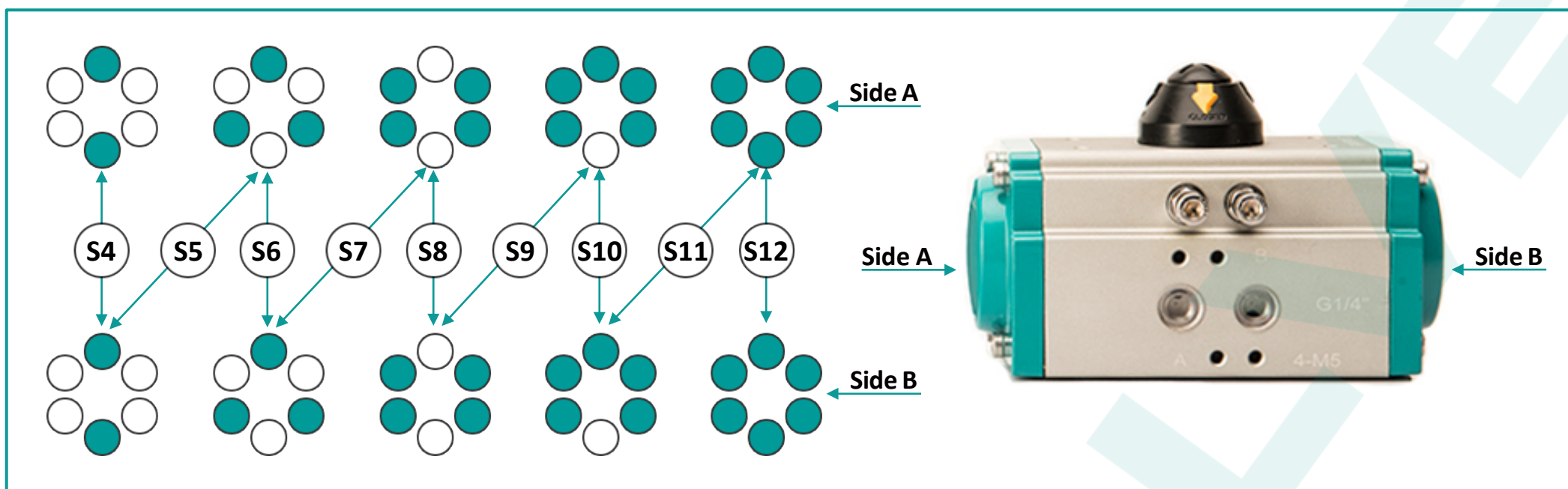

AIR CONSUMPTION AND OPENING AND CLOSING TIME

MODEL		PAC32	PAC40	PAC52	PAC63	PAC75	PAC83	PAC92	PAC105	PAC125	
CYLINDER AIR VOLUME (L)	OPEN	0.04	0.08	0.1	0.2	0.3	0.5	0.7	1.2	1.5	
	CLOSE	0.05	0.11	0.2	0.3	0.5	0.8	1.1	1.8	2.3	
OPENING & CLOSING TIME (SECOND)	DA	OPEN	0.1	0.1	0.2	0.3	0.3	0.4	0.5	0.7	0.9
		CLOSE	0.1	0.1	0.2	0.3	0.4	0.5	0.6	0.8	1.1
	SR	OPEN	-	-	0.3	0.3	0.4	0.5	0.7	0.9	1.2
		CLOSE	-	-	0.3	0.4	0.5	0.6	0.9	1.1	1.4
MODEL		PAC140	PAC160	PAC190	PAC210	PAC240	PAC270	PAC300	PAC350	PAC400	
CYLINDER AIR VOLUME (L)	OPEN	2.4	3.1	4.3	5.8	10.0	14.5	23.8	35.1	52.6	
	CLOSE	3.8	4.9	6.9	9.5	15.2	21.4	29.7	46.3	69.4	
OPENING & CLOSING TIME (SECOND)	DA	OPEN	1.2	1.5	2.0	2.7	3.5	4.0	8.0	10.0	10.0
		CLOSE	1.4	1.7	2.2	3.2	4.0	4.5	10.0	12.0	13.0
	SR	OPEN	1.5	1.8	2.4	3.5	4.1	4.5	7.0	8.0	8.0
		CLOSE	1.8	2.1	2.8	4.0	4.6	5.0	8.0	9.0	9.0

DOUBLE ACTING ACTUATOR OUTPUT TORQUE (UNIT : NM)

MODEL	INPUT AIR SUPPLY PRESSURE (UNIT : BAR)							
	2	3	4	5	6	7	8	
PAC32DA	3	5	6	8	9	11	12	
PAC40DA	4,8	7,2	9,6	12	14,4	16,8	19,2	
PAC52DA	8,5	12,7	17	21,2	25,5	29,7	34	
PAC63DA	15	22,5	30	37,5	44,9	52,4	59,7	
PAC75DA	21	31,8	42,4	53	63,6	74,2	84,8	
PAC83DA	32,5	48,7	65	81,2	97,4	113,7	130	
PAC92DA	46,5	69,8	93	116,3	140	162,9	186	
PAC105DA	69,3	104	138,5	173,2	207,8	242,5	277	
PAC125DA	108	162	216	270	324	378	432	
PAC140DA	184,7	277	369,5	461,8	554	646,5	739	
PAC160DA	281,5	422	563	704	844	985	1126	
PAC190DA	453	680	907	1135	1361	1587	1814	
PAC210DA	554	831	1108	1384	1662	1939	2216	
PAC240DA	814	1221	1628	2035	2442	2849	3256	
PAC270DA	1236	1854	2472	3090	3708	4326	4944	

SPRING RETURN ACTUATOR OUTPUT TORQUE (UNIT : NM)

AIR SUPPLY PRESSURE		3 BAR		4 BAR		5 BAR		6 BAR		7 BAR		8 BAR		OUTPUT TORQUE SPRING	
MODEL	SPRING QTY	0° START	90° END	0° START	90° END	0° START	90° END	0° START	90° END	0° START	90° END	0° START	90° END	0° START	90° END
PAC52SR	12	/	/	/	/	11.8	8.3	16	12.5	20.3	16.8	24.5	21	13	9.5
PAC63SR	12	/	/	/	/	21.1	13.5	28.6	21.0	36.1	28.5	43.6	36	23.9	16.3
PAC75SR	12	/	/	/	/	37.5	24.7	49.9	37.1	62.2	49.5	74.6	61.8	37.1	24.4
PAC83DR	12	/	/	/	/	45.5	29.5	61.8	45.8	78	62	94.2	78.2	51.6	35.6
PAC92SR	12	/	/	/	/	64	43.7	87.3	66.9	110.6	90.2	133.8	113.5	72.7	52.3
PAC105SR	12	/	/	/	/	78.9	62.4	113.5	97	148.1	131.6	182.8	166.3	110.8	94.3
PAC125SR	12	/	/	/	/	179	115	241	177	302	238	363	299	191	127
PAC140SR	12	/	/	/	/	248	142	341	234	433	327	525	419	320	214
PAC160SR	12	/	/	/	/	377	222	518	363	659	504	800	645	481	326
PAC190SR	12	/	/	/	/	577	297	804	524	1031	751	1258	978	837	557
PAC210SR	12	/	/	/	/	846	438	1158	750	1469	1062	1781	1373	1121	713
PAC240SR	12	/	/	/	/	1236	524	1725	1013	2213	1501	2702	1990	1919	1207
PAC270SR	12	/	/	/	/	1923	956	2610	1643	3297	2330	3985	3017	2480	1512

DIMENSION MM

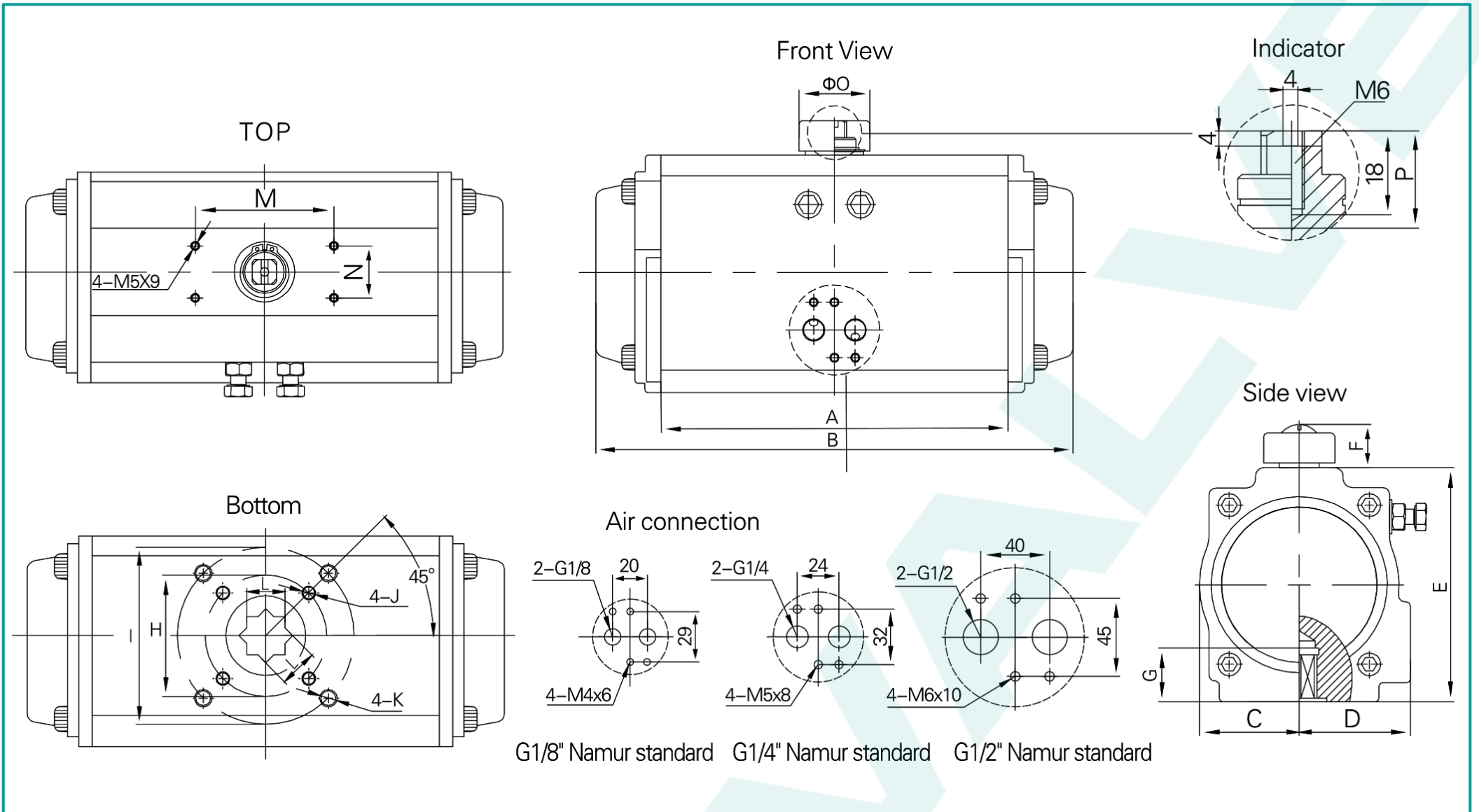

G1/8" Namur standard G1/4" Namur standard G1/2" Namur standard

MODEL		A	B	C	D	E	F	G	H	I	J	K	L	M	N	ØO	P	AIR SUPPLY	WEIGHT (KG)
PAC32	DA	90	112	23.5	23.5	45	26	12	F03	-	4-M5x8	-	9x9	50	30	34	20	G1/8	0.55
	SR																		-
PAC40	DA	93	123	23.5	33	60	26	12	F03	F05	4-M5x8	4-M6x10	11x11	50	30	34	20	G1/8	0.66
	SR																		-
PAC52	DA	108	145	30	41	72	26	15	F03	F05	4-M5x8	4-M6x10	11x11	80	30	34	20	G1/4	1.2
	SR																		1.3
PAC63	DA	125	169	46	46	89	26	15	F05	F07	4-M6x10	4-M8x12	14x14	80	30	34	20	G1/4	1.9
	SR																		2.1
PAC75	DA	128	201	42	52	100	26	15	F05	F07	4-M6x10	4-M8x12	14x14	80	30	34	20	G1/4	2.8
	SR																		3.1
PAC83	DA	147	209	46	55	109	26	15	F05	F07	4-M6x10	4-M8x12	17x17	80	30	34	20	G1/4	3.2
	SR																		3.7
PAC92	DA	168	242	51	57.5	117	26	20	F07	F10	4-M6x10	4-M8x12	17x17	80	30	41	20	G1/4	4.6
	SR																		5.2
PAC105	DA	186	275	58	64	134	26	25	F07	F10	4-M8x12	4-M10x16	22x22	80	30	41	20	G1/4	6.1
	SR																		7.1
PAC125	DA	207	332	67.5	70	157	36	25	F07	F10	4-M8x12	4-M10x16	22x22	80	30	62	30	G1/4	9.5
	SR																		10.9
PAC140	DA	268	400	76	77	174	36	30	F10	F12	4-M10x16	4-M12x20	27x27	130	30	62	30	G1/4	13.7
	SR																		15.7
PAC160	DA	308	455	87.5	87.5	199	38	30	F10	F12	4-M10x16	4-M12x20	27x27	130	30	62	30	G1/4	20.5
	SR																		23.6
PAC190	DA	390	507	103	103	232	38	40	-	F12	-	4-M12x20	36x36	130	30	79	30	G1/4	31.1
	SR																		35.3
PAC210	DA	390	562	113	113	257	38	40	-	F14	-	4-M16x20	36x36	130	30	79	30	G1/4	41.8
	SR																		46.6
PAC240	DA	430	646	129	129	293	38	52	-	F16	-	4-M20x24	46x46	130	30	79	30	G1/4	62.4
	SR																		72.4
PAC270	DA	510	722	146	146	333	38	52	-	F16	-	4-M20x24	46x46	130	30	79	30	G1/4	86.3
	SR																		98.3
PAC300	DA	579	825	162	173	354	38	52	-	F16	-	4-M20x24	46x46	130	30	79	30	G1/2	103
	SR																		143
PAC350	DA	580	866	190	195	410	38	52	-	F16	-	4-M20x24	46x46	130	30	79	30	G1/2	144
	SR																		188
PAC400	DA	-	924	258	258	464	38	60	-	F25	-	8-M16X24	55X55	130	30	79	30	G1/2	289
	SR																		360