

BPR

DESCRIPTION:

BPR Series back pressure regulators are designed for use as both economizers or diaphragm type pressure limiting devices on cryogenic liquid cylinders and systems. Optimized diaphragm and adjustment spring designs provide high flow above the desired setpoint. Robust metal-metal seal and seat design ensures low leakage rates below setpoint. The BPR Series is constructed of primarily brass and stainless steel for long-lasting performance. All BPR Series regulators are supplied factory pre-set and cleaned for oxygen service.

FEATURES:

- **OPTIMIZED FOR HIGH FLOW:** Designed for high flow rates in economizer and vent-to-atmosphere applications.
- **QUICK SHUT-OFF:** Regulators transition from the flowing condition to shut in a tight pressure band.
- **INLET FILTER SCREEN:** Protects against system debris and particulate.
- **DESIGNED FOR CRYOGENICS:** All materials were selected specifically for use in cryogenic environments.
- **FIELD ADJUSTABLE:** Regulators can be adjusted to any desired setpoint within the spring's pressure range.
- **CLEANED FOR OXYGEN SERVICE:** Regulators are cleaned for use in Oxygen service standard.



BPR-250

TECHNICAL DATA:

Maximum Inlet Pressure: 750 PSIG (51.7 bar)

Pressure Ranges:

Spring	Pressure Range	PSI/Turn*
A	15 to 65 PSIG (1.0 to 4.5 bar)	15
B	40 to 175 PSIG (2.7 to 12.1 bar)	25
C	100 to 350 PSIG (6.9 to 24.1 bar)	55
D	300 to 600 PSIG (20.7 to 41.4 bar)	85

*PSI/Turn Value is approximate change in setpoint per full turn of the adjustment screw (CW to increase, CCW to decrease), for reference only.

Temperature Range: -320° to 200°F (-196° to 93°C)

MATERIALS OF CONSTRUCTION:

Component	Material
Body, Chamber, Spring Button, Spring Retainer, Chamber Ring	CDA 360 Brass, ASTM B16
Adjustment Springs	Chrome Silicon, ASTM A401
Adjustment Screw, Locknut, Diaphragm Assembly Screw, Lock Washer	18-8 Stainless Steel
Poppet, Seat	303 SS, ASTM A313 Monel® 400
Diaphragms, Res. Damper	Phosphor Bronze
Inlet Filter Screen	Brass Wire Mesh, ASTM E437
Diaphragm Gasket	Vulcanex®
Chamber and Diaphragm Assembly Seal	Gylon®

NOTE: Regulators are assembled with Dupont Krytox® lubricant.



BPR-250I

SERIES

BACK PRESSURE REGULATOR

DIMENSIONAL DATA

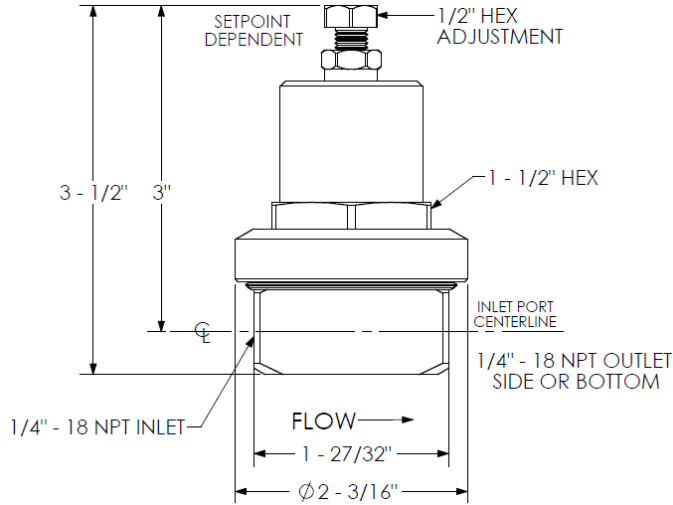

SPRING KITS

Part Number	Spring
BPR-SK-A	A (15 to 65 PSI)
BPR-SK-B	B (40 to 175 PSI)
BPR-SK-C	C (100 to 350 PSI)
BPR-SK-D	D (300 to 600 PSI)

All Replacement Spring Kits come with a Replacement Spring, Chamber Seal, and either Diaphragm Gasket (A, B, and C springs) or Chamber Ring (D Spring).

REPAIR KITS

Part Number	Description	Trim Mat'l
BPR-RK	Trim (Seat & Poppet Set), Diaphragms, Gasket, Seals, Filter Screen	303 SS
BPR-RK-M		Monel®

FLOW PERFORMANCE

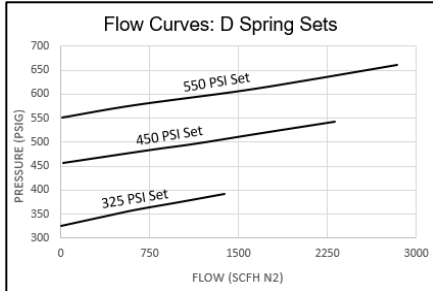
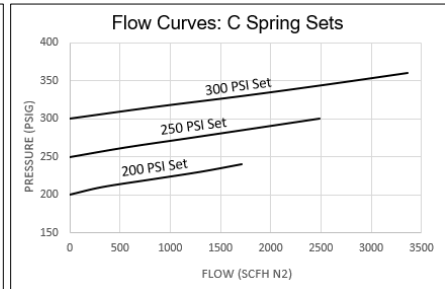
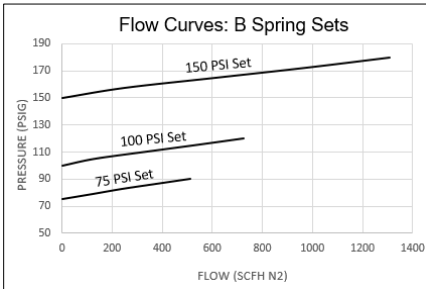
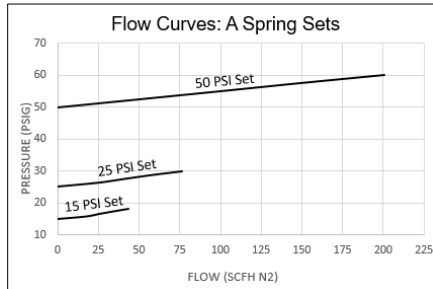

NOTES:

Flow Curves are derived from actual test data at test points up to 120% accumulation above set pressure.

All tests conducted with 0 PSIG on the outlet.

For flow information at higher overpressures, set pressures not listed, or for applications where back pressure is present on the outlet, consult factory.

HOW TO ORDER

BPR - 250 - B - 140 - M

SERIES
BPR - Back Pressure Regulator

PORT CONFIGURATION
250 - 1/4" NPT, Side IN - Bottom OUT
250I - 1/4" NPT, Side IN - Side OUT

M OPTION
Monel® Option for Poppet and Seat
OMIT for 303 SS Poppet and Seat

SET PRESSURE
Specify set pressure in PSI
OMIT FOR STANDARD SET (BY SPRING, SEE TABLE)

SPRING RANGE
A - 15 to 65 PSI (1.0 to 4.5 bar)
B - 40 to 175 PSI (2.7 to 12.1 bar)
C - 100 to 350 PSI (6.9 to 24.1 bar)
D - 300 to 600 PSI (20.7 to 41.4 bar)

Spring	Std. Set
A	35 PSI
B	125 PSI
C	300 PSI
D	450 PSI

Standard Sets do not come engraved with "Factory Set Pressure."

PROPER COMPONENT SELECTION – When specifying a component, the total system design must be considered to ensure safe and trouble-free performance. Intended component function, materials compatibility, pressure ratings, installation, environment and maintenance are the responsibility of the system designer.



1865 Route 23 South PO Box 768 Butler, New Jersey 07405 973.838.6500 Fax 973.838.4888