

SMT-multifunction manifold

SITEK - MULTIFUNCTION MANIFOLD

Assembly and supply manifold for solenoid valves, rotameters and other pneumatic devices.

Individual shut-off in each output facilitates safe on-line service or modification with pressure on.

Suitable for the most manufacturers' solenoid valves.

Manifold can also have laser marked position marks.



TECHNICAL DATA

Suitable fluids	Dry or lubricated air or gas
Input	1/2" R/G or NPT
Outputs	1/8", 1/4", 3/8", R/G or NPT
Number of outputs	2, 3, 4, 5, 6, 7, 8, 9, 10, 11, 12, 15, 16, 17, 18 Other sizes on request
Temperature range	- 20 ... + 90 ° C
Operating pressure	Vacuum ... 16 bar (232 psi)
Material	Anodised aluminium and nickel plated brass

Outputs can be equipped with ball valves.

Standard construction: individual shut-off valves, brackets, double nibble and end cap. End thread is always 1/2".

Manifold with NPT-thread: the character R on types shall be replaced with N, bracket height is 50, 65, 120 or 140 mm.

15 and 16 spacing 26,5 mm, all others, spacing is 33 mm.

TYPE CODE

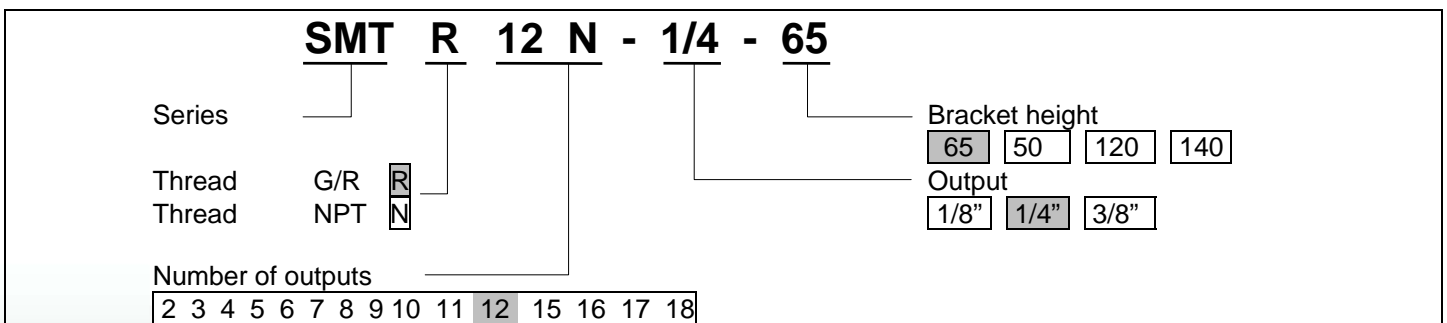

Example: Multifunction Manifold **SMT**, **R**-thread, **12** outputs/hand knob **N**, **1/4"** output thread, bracket height **65** mm

Patented product



Sitek-Service Ltd
Laukaantie 4
Hatanpäänvaltatie 34 A
E-mail: sitek@sitek.fi

40320 Jyväskylä Finland
33100 Tampere Finland
www.sitek.fi

Tel. +358 14 337 2300
Tel. +358 3 265 4069

Dimensions

Shut-off valve 1/2" (SPV-) (Optional)

Pressure gauge Ø 50 mm (SPM-) (Optional)

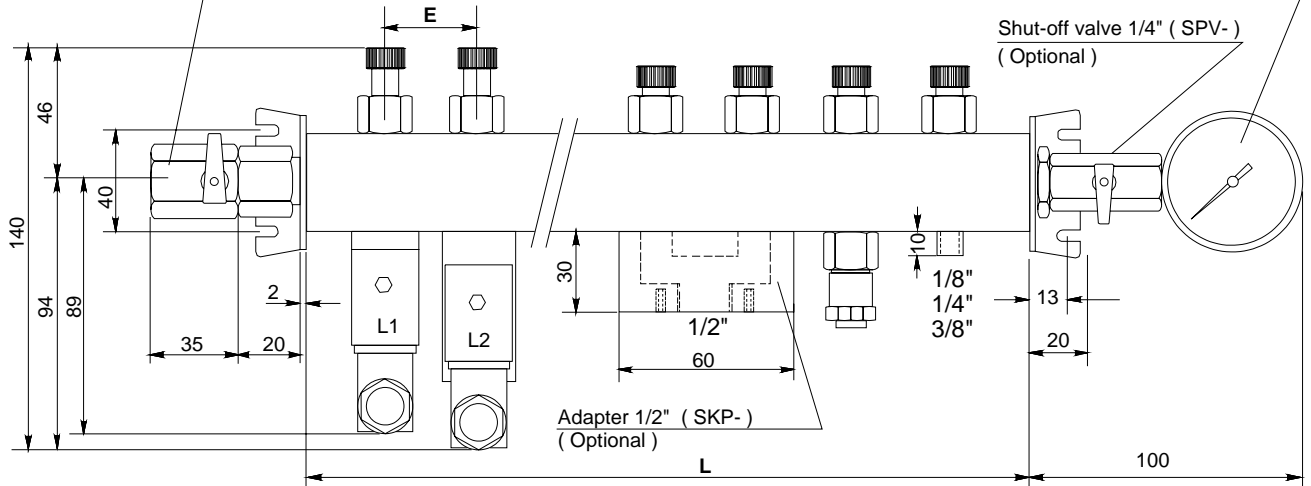

DIMENSIONS

Outputs 1/8", 1/4", 3/8" /kpl	2	3	4	5	6	7	8	9	10	11	12	15	16	17	18
Outputs 1/2" /kpl	1	1	2	2	3	3	4	4	5	5	6	7	8	8	9
Length L/mm	87	120	153	186	219	252	285	318	351	384	417	417	443,5	582	615
Spacing E/mm	33	33	33	33	33	33	33	33	33	33	33	26,5	26,5	33	33

Other dimensions on request

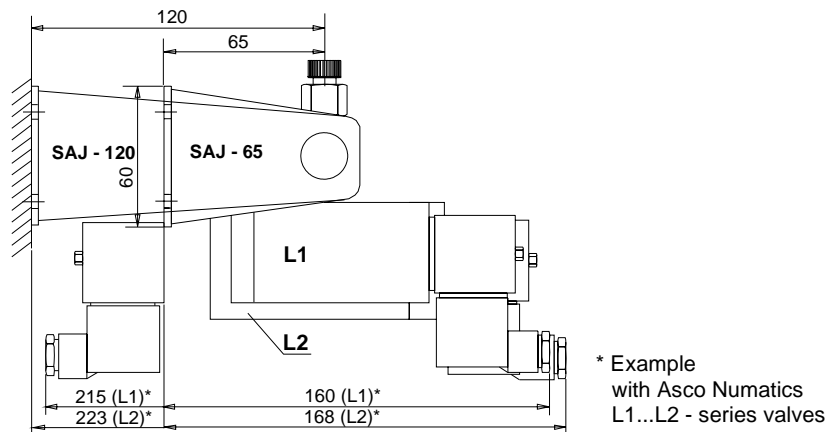

DEVICE MOUNTING

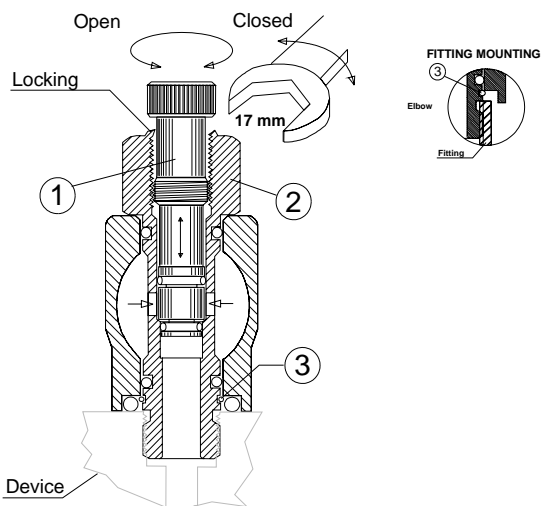

USING THE OUTPUT PORT

1. The Shut-Off Stem must be closed (lower position) when connecting or removing equipment.
2. Turn the Assembly Bolt to install or remove equipment..
3. The Locking Ring will lock the Assembly Bolt. No extra plugs needed.
4. The Fitting must be tightened slightly towards the elbow. This allows free rotation of the assembly and prevents the tube from being bent.

Seal the Fitting with glue. (O-ring does not work as sealing in this case)

Do not tighten too heavy, the Fitting will not tighten itself against the manifold body (Elbow damage).

Warning: Maximum tightening torque for assembly bolt 30 Nm (3 kpm)